

DAIMLER

Daimler Trucks North America
Nasser Zamani
Senior Manager
Compliance and Regulatory Affairs

October 7, 2011

Dan Smith
Associate Administrator for Vehicle Safety
National Highway Traffic Safety Administration
1200 New Jersey Avenue S.E.
Washington D.C. 20590

**Re: Defect Information Report – Supplemental Report No. 3
11V-160, FL-592, Business Class M2 Headlight Height
Dealer Notification**

Mr. Smith,

In accordance with Part 573 of Title 49 of the Code of Federal Regulations, Daimler Trucks North America LLC herewith submits supplemental defect information and copies of documents distributed to dealers.

- (c)(3) Total number of vehicles potentially affected: 298
- (c) (8)(ii) Dealer and distributor notification: Began and ended October 7, 2011
- (c) (10) A copy of communications sent to dealers is attached.

Please contact me if you have any questions.

Sincerely yours,



Nasser Zamani

Cc: Amy Martin, CAL-OSHA
Attachment

A Daimler Company

Daimler Trucks North America LLC
4747 N. Channel Avenue
Portland OR 97217-7699
503-745-6910 Phone
503-745-5544 Fax
Nasser.Zamani@Daimler.com

Subject: Business Class M2 Headlight Height

Models Affected: Specific Freightliner Business Class M2 vehicles manufactured July 19, 2010, through January 14, 2011.

General Information

Daimler Trucks North America LLC, on behalf of its Freightliner Trucks Division, has decided that the vehicles mentioned above fail to conform to Federal Motor Vehicle Safety Standard/Canadian Motor Vehicle Safety Standard (FMVSS/CMVSS) No 108, Lamps, Reflective Devices, and Associated Equipment.

There are approximately 300 vehicles involved in this campaign.

Certain vehicles may have been built with headlights that measure greater than 54 inches above the road surface. FMVSS/CMVSS 108 requires headlights to be not less than 22 inches nor more than 54 inches above the road surface. Improper headlight height may not fully illuminate the road surface or may inhibit the ability of motorists to see vehicles.

Vehicle headlight height will be measured. Any vehicles with headlamps above 54 inches will receive new headlamps that lower the bulb center to be at or below 54 inches. **IMPORTANT: Advance arrangements are required for this Recall. See Replacement Parts below for instructions.**

Additional Repairs

Dealers must complete all outstanding recall and field service campaigns prior to the sale or delivery of a vehicle. A Dealer will be liable for any progressive damage that results from its failure to complete campaigns before sale or delivery of a vehicle.

Owners may be liable for any progressive damage that results from its failure to complete campaigns within a reasonable time after receiving notification.

Work Instructions

Please refer to the attached work instructions. Prior to performing the campaign, check the vehicle for a completion sticker (Form WAR260).

Replacement Parts

Replacement parts are now available and can be obtained by ordering the kit or part number(s) listed below from your facing Parts Distribution Center.

If our records show your dealership has ordered any vehicles involved in campaign number FL592, a list of the customers and vehicle identification numbers will be available on AccessFreightliner.com. Please refer to this list when ordering parts for this recall.

Recall Campaign

Daimler Trucks
North America LLC

October 2011

FL592A

NHTSA #11V-160

Transport Canada #11-112

Parts Ordering Instructions

- **Recall Kits**

- Order with the vehicle serial number.
- The kit must be available at the dealership prior to the arrival of the vehicle.
- Freight may not be claimed.
- If a vehicle passes inspection and does not need the kit, retain it and use it for another vehicle.

- **Hood Templates**

- Order only if FL583 or FL592 will be performed at your location. One set of driver- and passenger-side hood templates may be ordered and claimed per location.
IMPORTANT: Label and do not lose the templates, a very limited quantity is available.
- The same templates are used for FL583 and FL592
- *Legacy Dealers:* Submit a WSC Campaign Pre-Approval Inquiry requesting authorization to order the hood templates, include the authorization number in the notes of the parts order and the claim on which the templates are listed.
- *OWL Dealers:* Submit an OWL Pre-Approval Request including the templates. Include the authorization number in the notes of the parts order. (OWL dealers may also request the templates using WSC.)
- For all dealers: Multiple requests for the hood templates will be denied.

Table 1 - Replacement Parts for FL592

Campaign Number	Kit Number	Part Description	Part Number	Qty. per Kit	Suggested Wholesale*
FL592A	25-FL592-000	Headlight Height Assembly LH	A06-81158-000	1 ea	\$3,041.97 U.S. \$3,102.81 CAN
		Headlight Height Assembly RH	A06-81158-001	1 ea	
		Turn Signal Lamp	A06-49322-001	2 ea	
		Housing, LH	A06-81197-002	1 ea	
		Housing, RH	A06-81197-003	1 ea	
		Bezel, LH	A06-81251-000	1 ea	
		Bezel, RH	A06-81251-001	1 ea	
		Turn Signal Retainer LH	06-82091-000	1 ea	
		Turn Signal Retainer RH	06-81270-001	1 ea	
		Bezel Edge Seal, LH	06-81270-000	1 ea	
		Bezel Edge Seal, RH	06-81270-001	1 ea	
		Washer, 1/4", SST	23-10900-025	18 ea	
		Screw, M6X1 - 15mm with patch lock	23-13012-715	6 ea	
		Nut, M6, SST, with nylon patch lock	23-12828-008	2 ea	
		Rivet, 1/4X0.375", Blind, Structural	23-13191-000	16 ea	
		Washer, 1/4"X3/4"X0.90", SST	23-10900-227	8 ea	
		Washer, 5/16", SST	23-10900-031	6 ea	
		Screw, M6X25	23-12781-725	4 ea	
		Screw, M6X16	A 220 984 04 29	8 ea	
		Nut-insert, 10mm	23-12509-420	2 ea	
		Double-end Screw, 6.6mm	23-12654-003	2 ea	
		Headlamp Jumper Harness	A06-81124-003	2 ea	
		Tie Strap, with Fir Tree	23-12654-003	10 ea	
		Reflector	GRO 40133	2 ea	
Screw, M4x16, SST	23-12642-716	4 ea			
Washer, #10, SST	23-10900-010	4 ea			
Nut, M4, Nylock	23-13107-004	4 ea			
Completion Sticker	WAR260	1 ea			
FL592A	Order By Part Number	Driver-side Hood Template	17-19640-000	1 ea	\$310.36 U.S. \$307.26 CAN
		Passenger-side Hood Template	17-19640-001	1 ea	\$310.36 U.S. \$307.26 CAN

* Please charge all Direct Warranty Customers the above-listed price for the kit, as they are authorized to perform their own Recalls.

Table 1

Recall Campaign

Daimler Trucks
North America LLC

October 2011
FL592A
NHTSA #11V-160
Transport Canada #11-112

Removed Parts

Please follow Warranty Failed Parts Tracking shipping instructions for the disposition of all removed parts.

Labor Allowance

Table 2 - Labor Allowance

Campaign Number	Procedure	Time Allowed (hours)	SRT Code	Damage Code
FL592A	Inspect headlight height	0.2	996-0852B	000-Inspected
FL592A	Inspect headlight height, modify hood, and retrofit headlights	3.9	996-0852A	000-Modifiedx

Table 2

IMPORTANT: When the recall has been completed, locate the base completion label in the appropriate location on the vehicle, and attach the red completion sticker provided in the recall kit (Form WAR260). If the vehicle does not have a base completion label, clean a spot on the appropriate location of the vehicle and first attach the base completion label (Form WAR259). If a recall kit is not required or there is no completion sticker in the kit, write the recall number on a blank sticker and attach it to the base completion label.

Claims for Credit

You will be reimbursed for your parts, labor, and handling by submitting your claim through the Warranty system within 30 days of completing this campaign. Please reference the following information in QuickClaim®:

- Claim type is **Recall**.
- In the FTL Authorization field, enter the campaign number and appropriate condition code (**FL592A**).
- In the Primary Failed Part Number field, enter **25-FL592-000**.
- In the Parts field, enter the appropriate kit or part number(s) as shown in the Replacement Parts Table. **IMPORTANT: Review instructions in Replacement Parts above before submitting claims or ordering kits/templates.**
- In the Labor field, first enter the appropriate SRT from the Labor Allowance Table. For administrative time, enter SRT 939-0010A for 0.3 hours.
- For OWL, the VMRS Component Code is 002-004-001.
- **Reimbursement for Prior Repairs.** When a customer asks about reimbursement, please do the following.
 - Accept the documentation of the previous repair.
 - Make a brief check of the customer's paperwork to see if the repair may be eligible for reimbursement. (See the "Copy of Owner Letter" section of this bulletin for reimbursement guidelines for this recall.)
 - Submit a Campaign Pre-Approval inquiry to the Warranty Campaigns Department for a decision and authorization number.
 - Include the approved amount on your claim in sublet/outside purchases.
 - In the claim story, first note the authorization number and that the claim includes a reimbursement request.
 - Retain the documentation and provide it to Warranty Campaigns or Claims Processing if requested.
 - When your claim is paid, reimburse the customer the appropriate amount.

October 2011
FL592A
NHTSA #11V-160
Transport Canada #11-112

IMPORTANT: ServicePro® must be viewed prior to performing the recall to ensure the vehicle is involved and the campaign has not been previously completed. Also, check for a completion sticker prior to beginning work.

Contact the Warranty Campaigns Department from 7:00 a.m. to 4:00 p.m. Pacific Time, Monday through Friday, via Web inquiry at AccessFreightliner.com / Support / My Tickets and Submit an Inquiry, or the Customer Assistance Center at (800) 385-4357, after normal business hours, if you have any questions or need additional information.

To return excess kit inventory related to this campaign, U.S. dealers must submit a Parts Authorization Return (PAR) to the Memphis PDC. Canadian dealers must submit a PAR to their facing PDC. All kits must be in resalable condition. PAR requests must include the original purchase invoice number.

The letter notifying vehicle owners is included for your reference.

Please note that the National Traffic and Motor Vehicle Safety Act, as amended (Title 49, United States Code, Chapter 301), requires the owner's vehicle(s) be corrected within a reasonable time after parts are available to you. The Act states that failure to repair a vehicle within 60 days after tender for repair shall be prima facie evidence of an unreasonable time. However, circumstances of a particular situation may reduce the 60 day period. Failure to repair a vehicle within a reasonable time can result in either the obligation to (a) replace the vehicle with an identical or reasonably equivalent vehicle, without charge, or (b) refund the purchase price in full, less a reasonable allowance for depreciation. The Act further prohibits dealers from selling a vehicle unless all outstanding recalls are performed. Any lessor is required to send a copy of the recall notification to the lessee within 10 days. Any subsequent stage manufacturer is required to forward this notice to its distributors and retail outlets within five working days.

Recall Campaign

Daimler Trucks
North America LLC

October 2011
FL592A
NHTSA #11V-160
Transport Canada #11-112

Copy of Letter to Owner

Subject: Business Class M2 Headlight Height

For the Notice to U.S. Customers: This notice is sent to you in accordance with the requirements of the National Traffic and Motor Vehicle Safety Act.

For the Notice to Canadian Customers: This notice is sent to you in accordance with the Canadian Motor Vehicles Safety Act.

Daimler Trucks North America LLC, on behalf of its Freightliner Trucks Division, has decided that specific Freightliner Business Class M2 vehicles manufactured July 19, 2010, through January 14, 2011, fail to conform to Federal Motor Vehicle Safety Standard/Canadian Motor Vehicle Safety Standard (FMVSS/CMVSS) No 108, Lamps, Reflective Devices, and Associated Equipment.

Certain vehicles may have been built with headlights that measure greater than 54 inches above the road surface. FMVSS/CMVSS 108 requires headlights to be not less than 22 inches nor more than 54 inches above the road surface. Improper headlight height may not fully illuminate the road surface or may inhibit the ability of motorists to see vehicles.

Vehicle headlight height will be measured. Any vehicles with headlamps above 54 inches will receive new headlamps that lower the bulb center to be at or below 54 inches.

Please contact an authorized Daimler Trucks North America dealer to arrange to have the Recall performed. **IMPORTANT:** Advance arrangements are required for this Recall to ensure parts are available for your vehicle prior to your arrival. To locate an authorized dealer, search online at www.Daimler-TrucksNorthAmerica.com. The Recall may take up to four hours and will be performed at no charge to you.

If you do not own the vehicle that corresponds to the identification number(s) which appears on the Recall Notification, please return the notification to the Warranty Campaigns Department with any information you can furnish that will assist us in locating the present owner. If you have leased this vehicle, Federal law requires that you forward this notice to the lessee within 10 days. If you are a subsequent stage manufacturer, Federal law requires that you forward this notice to your distributors and retail outlets within five working days. If you have paid to have this recall condition corrected prior to this notice, you may be eligible to receive reimbursement. Please see the reverse side of this notice for details.

For the Notice to U.S. Customers: If you have questions about this Recall, please contact the Warranty Campaigns Department at (800) 547-0712, 7:00 a.m. to 4:00 p.m. Pacific Time Monday through Friday, e-mail address DTNA.Warranty.Campaigns@Daimler.com, or the Customer Assistance Center at (800) FTL-HELP after normal business hours. If you are not able to have the defect remedied without charge and within a reasonable time, which is not longer than 60 days after you tender the vehicle for repair, you may wish to submit a complaint to the Administrator, National Highway Traffic Safety Administration, 1200 New Jersey Avenue, SE., Washington, DC 20590; or call the Vehicle Safety Hotline at (888) 327-4236 (TTY: 800-424-9153); or to <http://www.safercar.gov>.

For the Notice to Canadian Customers: If you have questions about this Recall, please contact the Warranty Campaigns Department at (800) 547-0712, 7:00 a.m. to 4:00 p.m. Pacific Time Monday through Friday, e-mail address DTNA.Warranty.Campaigns@Daimler.com, or the Customer Assistance Center at (800) FTL-HELP after normal business hours.

We regret any inconvenience this action may cause but feel certain you understand our interest in motor vehicle safety.

WARRANTY CAMPAIGNS DEPARTMENT

Enclosure

Reimbursement to Customers for Repairs Performed Prior to Recall

If you have already **paid** to have this recall condition corrected you may be eligible to receive reimbursement.

Requests for reimbursement may include parts and labor. Reimbursement may be limited to the amount the repair would have cost if completed by an authorized Daimler Trucks North America LLC dealer. The following documentation must be presented to your dealer for consideration for reimbursement.

Please provide original or clear copies of all receipts, invoices, and repair orders that show:

- The name and address of the person who paid for the repair.
- The Vehicle Identification Number (VIN) of the vehicle that was repaired.
- What problem occurred, what repair was done, when the repair was done.
- Who repaired the vehicle.
- The total cost of the repair expense that is being claimed.
- Proof of payment for the repair (such as the front and back of a cancelled check or a credit card receipt).

Reimbursement will be made by check from your Daimler Trucks North America LLC dealer.

Please speak with your Daimler Trucks North America LLC authorized dealer concerning this matter.

October 2011
FL592A
NHTSA #11V-160
Transport Canada #11-112

Work Instructions

Subject: Business Class M2 Headlight Height

Models Affected: Specific Freightliner Business Class M2 vehicles manufactured July 19, 2010, through January 14, 2011.

Parts Ordering Instructions

- **Recall Kits**
 - Order with the vehicle serial number.
 - The kit must be available at the dealership prior to the arrival of the vehicle.
 - Freight may not be claimed.
 - If a vehicle passes inspection and does not need the kit, retain it and use it for another vehicle.
- **Hood Templates**
 - Order only if FL583 or FL592 will be performed at your location. One set of driver- and passenger-side hood templates may be ordered and claimed per location.
IMPORTANT: Label and do not lose the templates, a very limited quantity is available.
 - The same templates are used for FL583 and FL592
 - *Legacy Dealers:* Submit a WSC Campaign Pre-Approval Inquiry requesting authorization to order the hood templates, include the authorization number in the notes of the parts order and the claim on which the templates are listed.
 - *OWL Dealers:* Submit an OWL Pre-Approval Request including the templates. Include the authorization number in the notes of the parts order. (OWL dealers may also request the templates using WSC.)
 - For all dealers: Multiple requests for the hood templates will be denied.

Headlight Height Inspection and Modification

IMPORTANT: Do not begin this procedure until the Recall kit and hood templates are available for your use.

1. Check the base label (Form WAR259) for a completion sticker for FL592 (Form WAR260) indicating this work has been done. The base label is usually located on the passenger-side door about 12 inches (30 cm) below the door latch. If a sticker for FL592 is present, no work is needed. If no sticker is present, go to the next step.
2. Shut down the engine, set the parking brakes, and chock the tires.
3. Check the height of the headlights.
 - 3.1 Make sure that the vehicle is on a level surface, that it is not carrying a load, and that the tires are properly inflated.

NOTE: Proper tire inflation is recommended at 90 to 100 psi (620 to 690 kPa).

- 3.2 Measure from the ground to the center of the highest headlight lens. See **Fig. 1** and **Fig. 2**. If this height is 54 inches (137 cm) or less, nothing more needs to be done. Clean a spot on the base label (Form WAR259) and attach a completion sticker for FL592 (Form WAR260) to the base label.

If the distance is more than 54 inches (137 cm), go to the next step.

4. Disconnect the batteries.
5. Remove the headlight assemblies.
 - 5.1 Open the hood.
 - 5.2 Disconnect the headlight and park/turn signal light electrical connectors and any tie straps that might be holding them to the headlight bucket assembly.
 - 5.3 Remove the nuts from the two lower mounting adjustment studs. See **Fig. 3**.
 - 5.4 Remove the capscrew from the upper mounting bracket.
 - 5.5 Remove the headlight assembly.
 - 5.6 Close the hood.
6. Around the right and left headlights, apply masking tape around the headlight opening to provide a surface to trace a guide for the saw. See **Fig. 4**.
7. If not already done, label both hood templates for use with FL583 and FL592.
8. Position the appropriate template over each headlight assembly and secure it with two clamps. See **Fig. 5**. Secure one clamp on the top center of the opening, and the other clamp along the lower edge of the grille opening.
9. Draw an outline on the tape using the edge of the template on each side of the vehicle.
10. Remove the templates. The guide lines for the saw should be clearly visible. See **Fig. 6**.
11. Using a metal saw, cut along the guide line. See **Fig. 7**. Use care to adjust the saw and cut around the casting and the wiring support bracket. Repeat on the other side of the vehicle. See **Fig. 8**.
12. Remove the cut pieces of the headlight openings and remove any remaining tape. See **Fig. 9**.
13. Open the hood.
14. Install the new headlight assemblies. See **Fig. 10** and **Fig. 11**.
 - 14.1 Install the headlight assembly in the vehicle.
 - 14.2 Install the capscrew in the upper mounting bracket.
 - 14.3 Install the nuts in the two lower mounting adjustment studs.
 - 14.4 Install the headlight and park/turn signal light electrical connectors and use tie straps to secure them to the headlight bucket assembly.
15. Have an assistant position and hold the headlight bezel on the hood.
16. Install the mounting capscrews.
17. Install the headlight cover.
18. Close the hood.
19. Connect the batteries.
20. Check the height of the headlights. Measure from the ground to the center of the highest headlight lens. See **Fig. 1** and **Fig. 2**. The height should be 54 inches (137 cm) or less.
21. Clean a spot on the base label (Form WAR259) and attach a completion sticker for FL592 (Form WAR260) to the base label.

Recall Campaign

Daimler Trucks
North America LLC

October 2011
FL592A
NHTSA #11V-160
Transport Canada #11-112

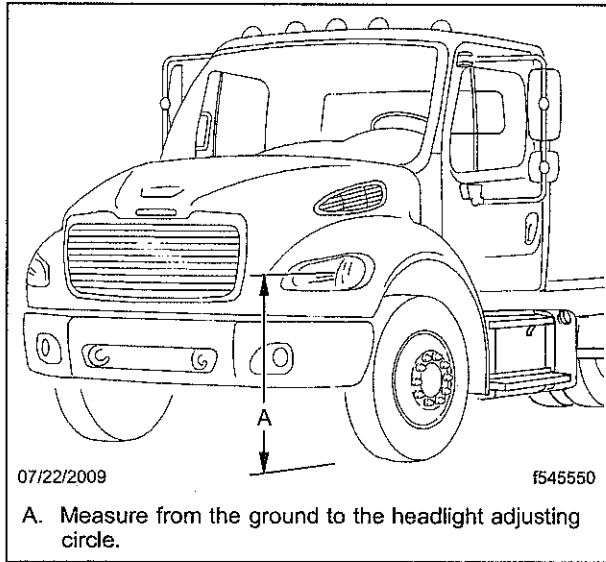

A. Measure from the ground to the headlight adjusting circle.

Fig. 1, Headlight Measurement

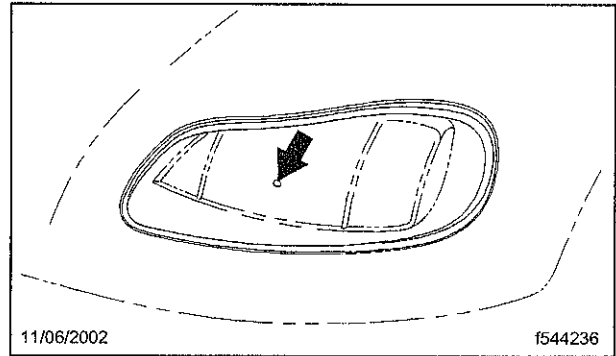
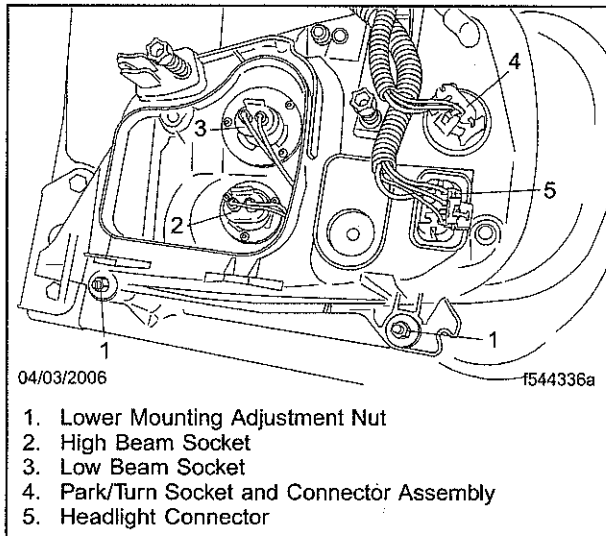

Fig. 2, Headlight Adjusting Circle



1. Lower Mounting Adjustment Nut
2. High Beam Socket
3. Low Beam Socket
4. Park/Turn Socket and Connector Assembly
5. Headlight Connector

Fig. 3, Headlight Bucket (rear view)

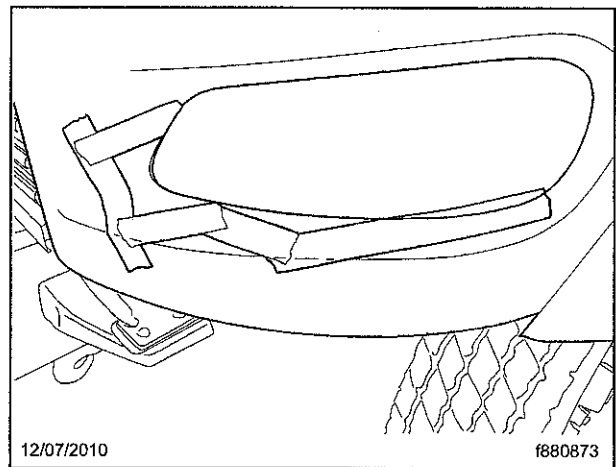

Fig. 4, Masking Tape Secured Around the Headlight Opening

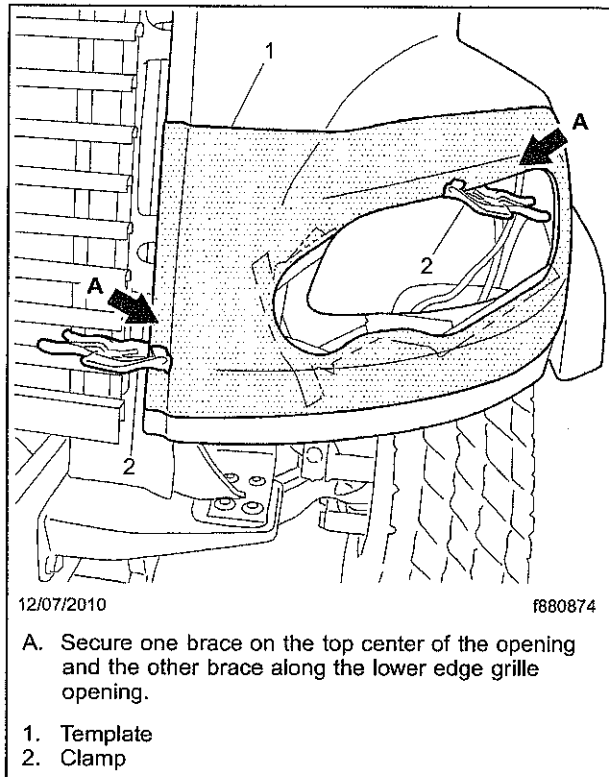

Fig. 5, Securing the Template to the Headlight Opening

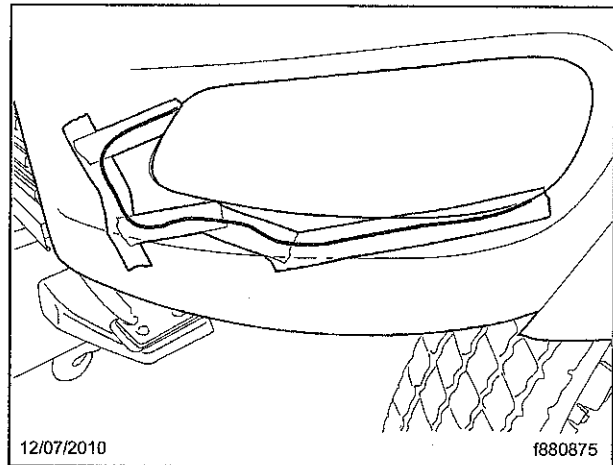

Fig. 6, Guide Line for the New Headlight Opening

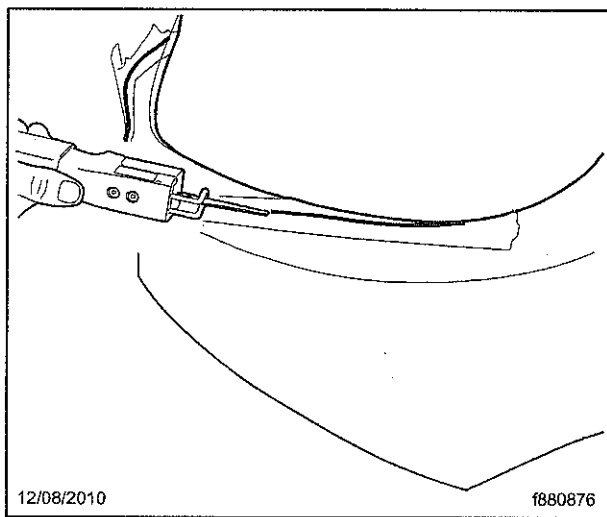

Fig. 7, Cutting Along the Guide Line

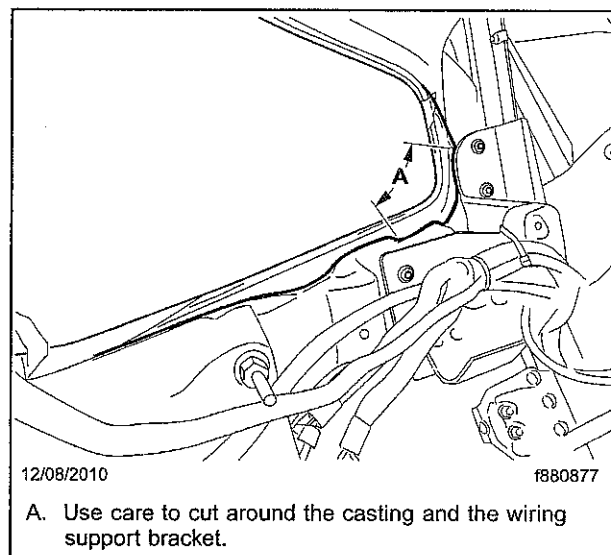

Fig. 8, Cutting Around the Casting

Recall Campaign

Daimler Trucks
North America LLC

October 2011
FL592A
NHTSA #11V-160
Transport Canada #11-112

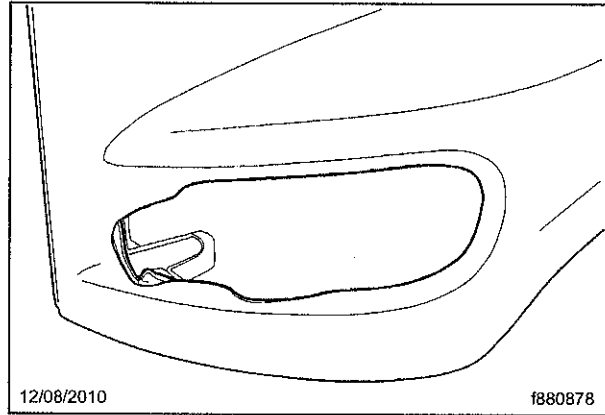

Fig. 9, New Headlight Opening

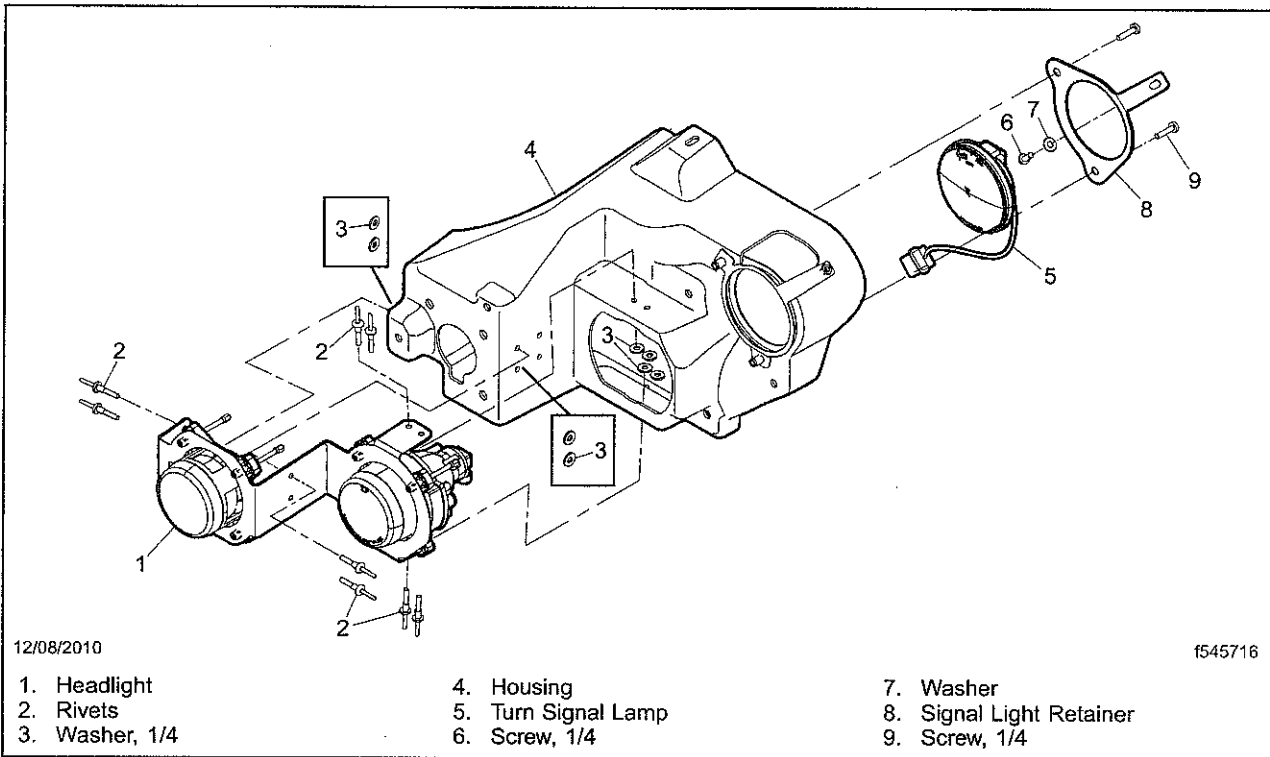

Fig. 10, New Headlight Assembly

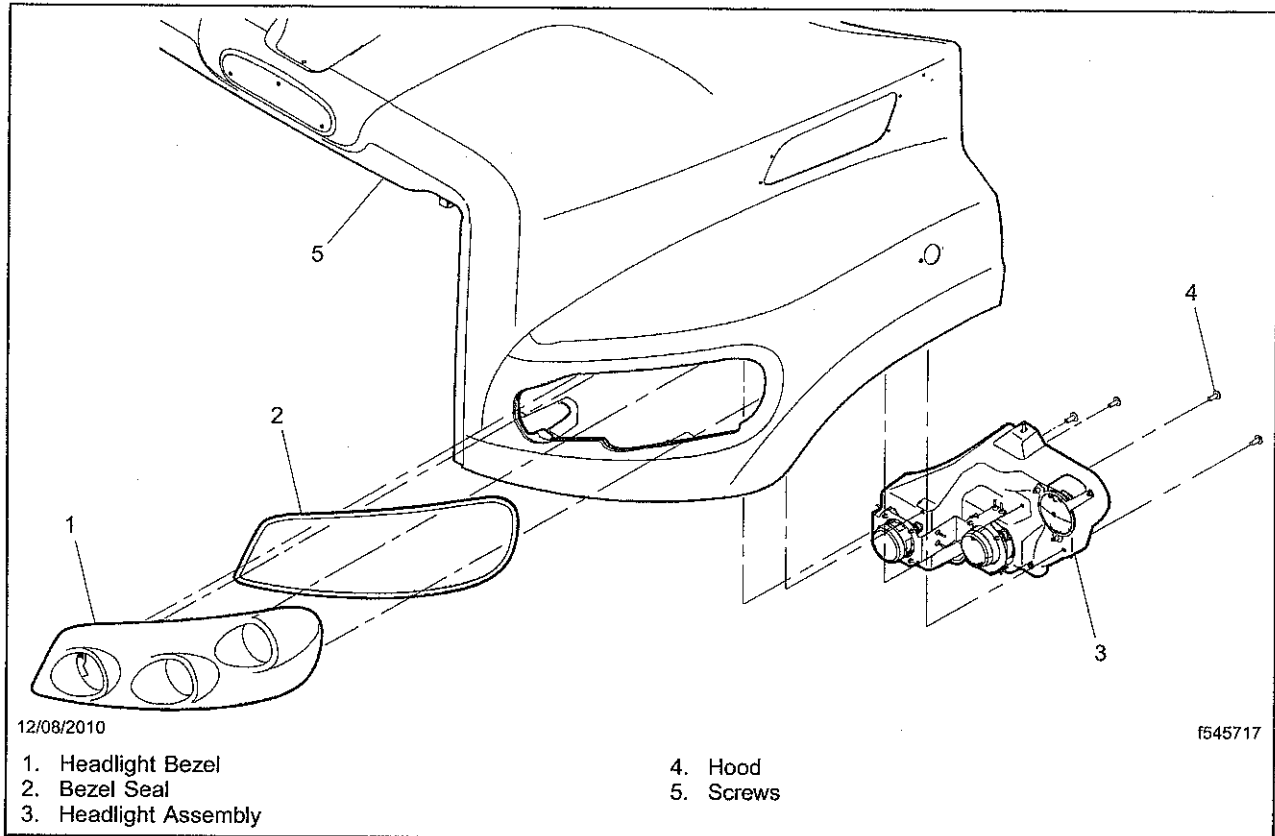

Fig. 11, Headlight Installation