

# Case 495 : Narrative

Case Vehicle (A): 1999 Nissan
Type: Sentra GXE, 4-door sedan
Driver: 25-year-old male
CDC: 12-FDEW-2

## SITUATION

[1](#) [2](#) On a cloudy night, case vehicle (A) was traveling east at a driver-estimated speed of 65 mph (105 kph) in the center lane of three eastbound lanes of a limited-access highway in a rural area. The road surface was dry and unlighted and the speed limit was 70 mph (113 kph). As case vehicle (A) approached a split in the highway where traffic in the left and center lanes can exit to the left to travel north on an intersecting highway and traffic in the center and right lanes can continue east, [3](#) the driver fell asleep. Case vehicle (A) went straight, exited the road where it divides, and the front struck and broke the leading edge of a guardrail. Case vehicle (A) came to rest in the grass beyond the guardrail, facing east. The vehicle was towed from the scene due to damage. The police accident report indicates B-level injuries for the belt-restrained male driver of case vehicle (A), who did not seek any medical treatment.

## GENERAL VEHICLE DAMAGE AND ESTIMATED CRASH SEVERITIES

[4](#) The direct damage to the front of case vehicle (A) was moderate and extended across the entire front of the vehicle. [5](#) [6](#) The maximum rearward crush was 46 cm and it occurred at the center of the bumper.

[7](#) [8](#) [9](#) [10](#) [11](#) Using the equivalent barrier algorithm of the WinSMASH crash-reconstruction program and the crush profiles measured for case vehicle (A), the following impact severity was estimated for the impact with the guardrail, which is probably high because the guardrail deformed and broke.

		Estimated Velocity Change - kph (mph)		
Vehicle	Variable	Total	Longitudinal	Latitudinal
Case Vehicle (A)	EBS	43 (27)	-43 (-27)	0 (0)

## DESCRIPTION OF DAMAGE TO CASE VEHICLE (A)

### Exterior

[12](#) In the front, the entire front end was crushed rearward into the engine compartment and the front bumper cover was completely separated from its attachments. [13](#) [14](#) The grille was crushed, both headlight assemblies were shattered, [15](#) the right section of the hood was pushed down, and the [16](#) left side the hood was slightly elevated. The damaged hood latch had released and both hood hinges were bent up, which allowed the rear edge of the hood to elevate. [17](#) [18](#) Both hood hinges contacted and

cracked the lower corners of the windshield and [19](#) [20](#) cracks radiated across the entire width of the windshield. The roof was buckled just above the center of the windshield.

[21](#) [22](#) On the left side, the fender was crumpled and almost completely separated from its attachments. [23](#) The fender was pushed into the left-front tire, the tire was separated from the rim and deflated, and the left wheelbase was reduced by 6 cm. [24](#) There was no other damage to the left side of the case vehicle.

[25](#) On the right side, the fender was crumpled, the [26](#) right-front axle was damaged, and the right-side wheelbase was reduced by 7 cm. [27](#) [28](#) There was no other damage to the right side or [29](#) to the rear of the case vehicle.

## Interior

[30](#) This vehicle was equipped with steering-wheel and dash-mounted frontal-impact airbags, which deployed during the frontal impact into the guardrail. [31](#) In the driver-seating area, there was no damage to the steering-wheel assembly [32](#) but the cover of the cruise-control module was missing from the right side of the steering hub. [33](#) [34](#) There was no rotation of the steering column and there was no damage to the [35](#) deployed airbag or airbag module cover, but there were brown marks on the lower-left section [36](#) [37](#) and bloodstains on the upper-right section of the airbag fabric. There was no damage to the upper section of the instrument panel [38](#) [39](#) but the light-control panel was pulled out from the mid section. [40](#) The left side of the knee bolster was cracked and the fuse-box cover was separated from the bolster cover. [41](#) The floor was displaced up, [42](#) the toepan was displaced rearward, and the [43](#) accelerator pedal was bent to the left. [44](#) [45](#) There was no other damage in the driver area.

[46](#) [47](#) [48](#) In the center-front area, the rearview mirror was separated from the windshield but the mirror glass was intact but there was no other damage. [49](#) [50](#) [51](#) [52](#) In the right-front seating area, the floor was displaced up and the toepan was displaced rearward but there was no other damage.

[49](#) [53](#) The following intrusions were noted and measured:

Location	Component	Distance (cm)	Direction
left front	toepan	8	to rear
	floor	5	up
right front	toepan	7	to rear
	floor	3	up

## OCCUPANT KINEMATICS AND INJURIES

[54](#) The 193-cm, 122-kg (6-ft 4-in, 270-lb) 25-year-old male driver was using the available three-point belt [58](#) with the shoulder-belt anchor point on the B-pillar adjusted to the highest position, [35](#) and the steering-wheel airbag deployed. [55](#) [56](#) Belt use at the time of the crash is indicated by light loading marks on the continuous loop but [57](#) there were no loading marks on the D-ring or on the belt webbing. During the frontal impact, the driver moved forward into the belt restraints and airbag. He sustained a bloody nose, probably from contact by the deploying airbag. He sustained a contusion to the left knee and leg just below the knee from contact with the left side of the knee bolster and fuse-box, as evidenced by damage to the covers of both. He sustained a contusion to the right knee and leg just below the knee, probably from contact with the right side of the knee bolster.

The attached table [59](#) and drawing summarizes the injuries for the belt-and-airbag restrained driver.

Occupant: Driver	Age: 25 years	Gender: Male		
Restraints: 3-point belt; steering-wheel airbag	Stature: 193 cm (6 ft, 4 in)	Mass: 122 kg (270 lb)		
Injury Description	A.I.S.	Injury Source		
		Definite	Probable	Possible
—	—	—	—	—
Bloody nose	1	—	Deploying airbag	—
Contusion, left knee	1	Knee bolster and/or fuse box	—	—
Contusion, left leg below the knee	1	Knee bolster and/or fuse box	—	—
Contusion, right knee	1	—	Knee bolster	—
Contusion, right leg below the knee	1	—	Knee bolster	—
Maximum A.I.S. Level	1	—	—	—
Injury Severity Score	2	—	—	—

CASE NO.: 495

CASE VEHICLE: 1999 Nissan

TYPE: Sentra GXE, 4-door sedan

OCCUPANT: (Driver) 25-year-old male

STATURE: 193 cm (6 ft, 4 in) MASS: 122 kg (270 lb)

RESTRAINTS: 3-point belt; steering-wheel airbag

SEVERITY: MAIS - 1 ISS - 2

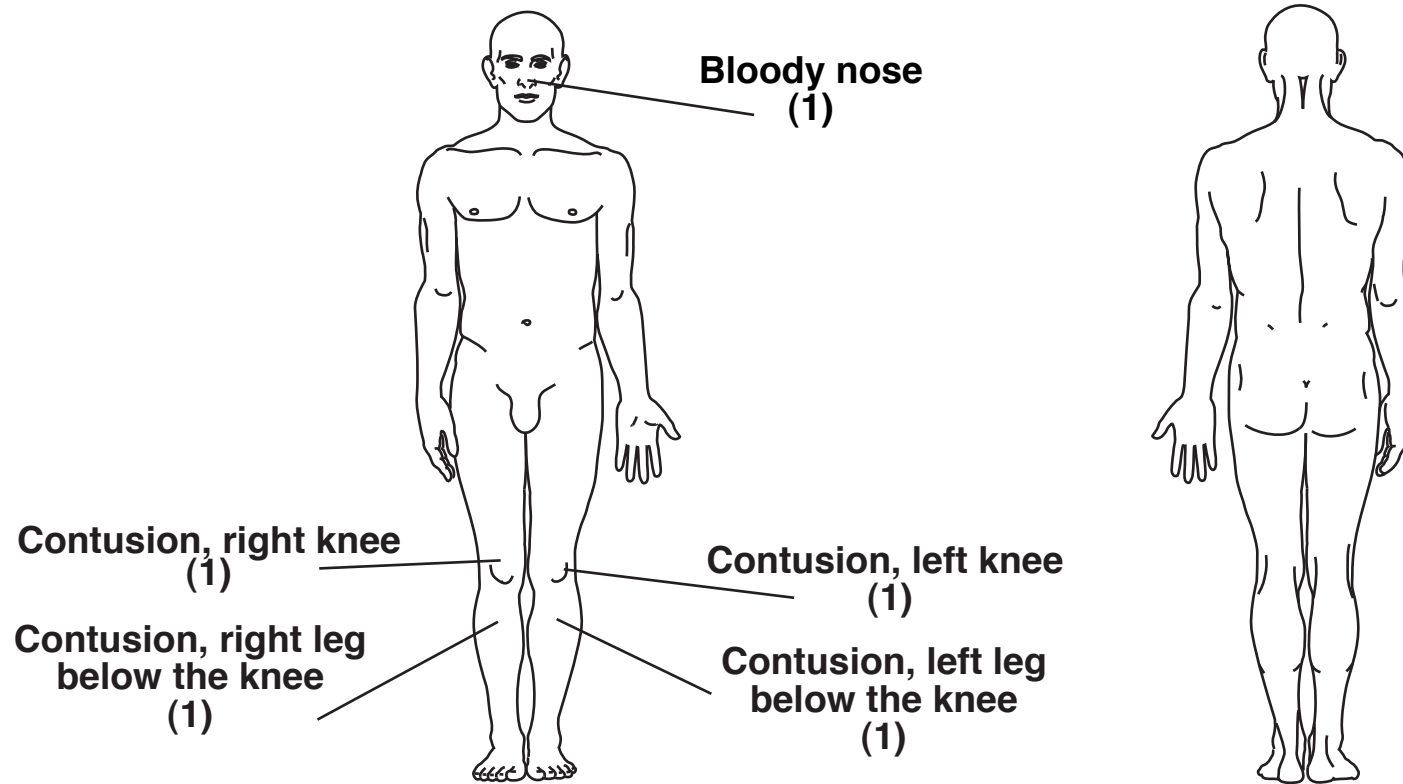

Case No.: 495  
Case Veh. (A): 1999 Nissan  
Type: **Sentra GXE, 4-door sedan**  
Driver: **25-year-old male**

Weather: **Cloudy**  
Road Surface: **Dry**  
Road Construction: **Asphalt**  
Light Condition: **Dark/unlighted**

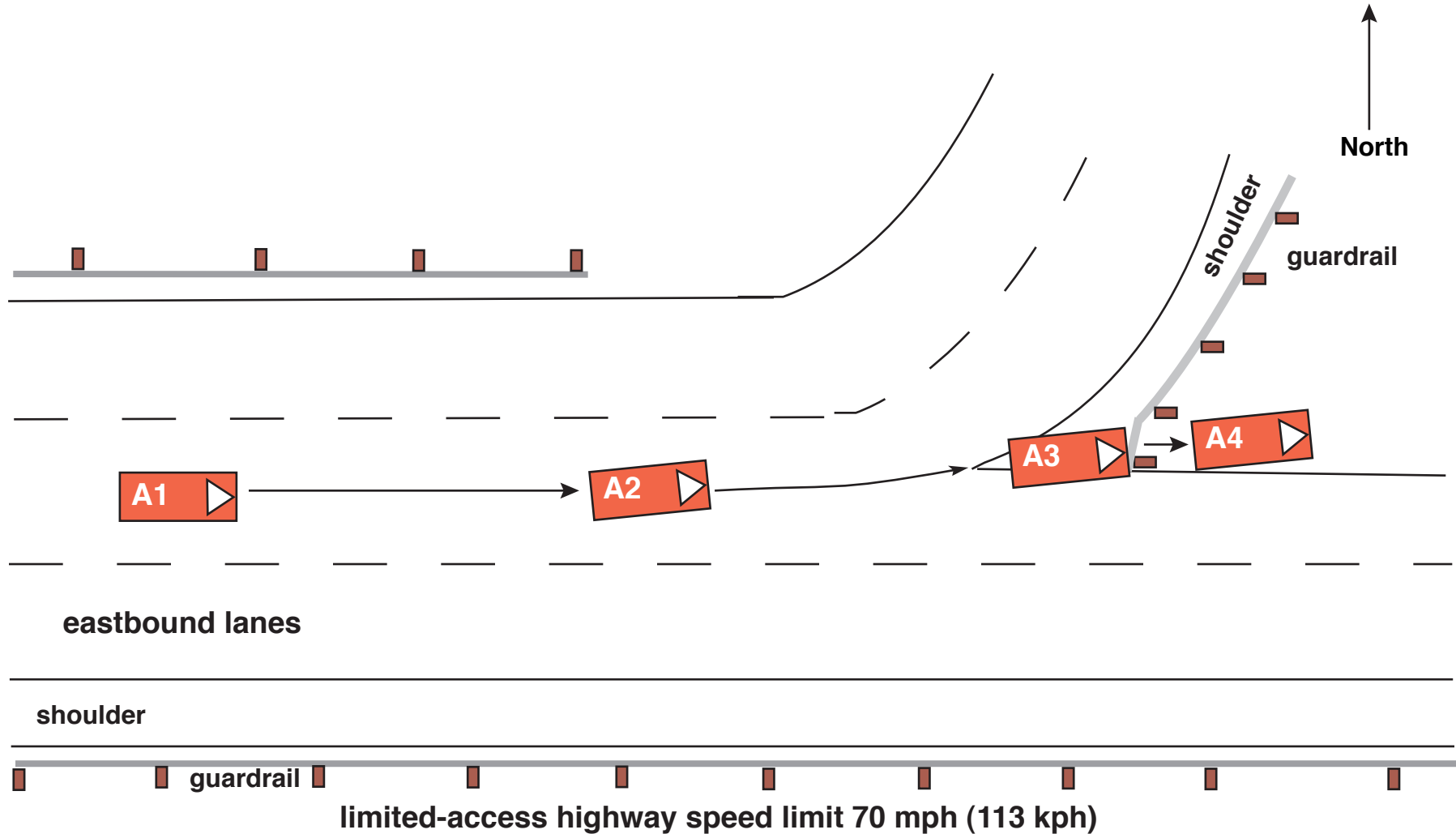

limited-access highway speed limit 70 mph (113 kph)

# 495: Vehicle Report

Click on Section Name to jump directly to that Section —

- [General Information](#)
- [Other Vehicle](#)
- [Case Vehicle General](#)
- [Case Vehicle Damage Description](#)
- [Crash Reconstruction](#)
- [Case Vehicle Tires & Rims](#)
- [Case Vehicle Fuel Tank](#)
- [Case Vehicle Fuel Leakage](#)
- [Case Vehicle Fire](#)
- [Case Vehicle Exterior](#)
- [Case Vehicle Steering Column/Rim](#)
- [Case Vehicle Intrusion](#)
- [Case Vehicle Airbag\(s\)](#)
- [Case Vehicle Interior](#)
- [Case Vehicle Seats](#)
- [Case Vehicle Side Airbag\(s\)](#)
- [EDR -- Event Data Recorder](#)

## General Information

[Back to Top](#)

Variable Number	Variable Name	Code Value	Code Description	Other Options
V0204	Collision Hour	2003	Time of day (24 hour clock)	<a href="#">more</a>
V0205	State Fips Code	26	Michigan	<a href="#">more</a>
V0206	Urban/rural Area	2	Rural	<a href="#">more</a>
V0207	Limited Access Highway	1	Yes	<a href="#">more</a>
V0208	Road Total Lanes	5	Divided, 4 lanes or more	<a href="#">more</a>
V0209	Intersect Road Total Lanes	2	2 lanes	<a href="#">more</a>
V0210	Trafficway Flow	2	Divided trafficway - median strip with positive	<a href="#">more</a>
V0211	Road Surface Type	1	Asphalt	<a href="#">more</a>
V0212	Road Defects	0	No	<a href="#">more</a>
V0213	Construction Zone	0	No	<a href="#">more</a>
	Road Alignment Vertical			

V0214	Plane	1	Level	<a href="#">more</a>
V0215	Road Alignment Horizontal Plane	4	Y-shaped	<a href="#">more</a>
V0216	Surface Covering	10	Dry	<a href="#">more</a>
V0217	Visibility Limitation	0	None	<a href="#">more</a>
V0218	Visibility Obstruction	0	None	<a href="#">more</a>
V0219	Speed Limit	8	106+ km/h .. 65+ mph	<a href="#">more</a>
V0220	Precipitation Type	0	None	<a href="#">more</a>
V0221	Precipitation Rate	8	Not applicable	<a href="#">more</a>
V0222	Temperature	8	Over 35 C .. over 96 F	<a href="#">more</a>
V0223	Crosswind	9	Unknown	<a href="#">more</a>
V0224	Light Conditions	5	Dark, unlighted	<a href="#">more</a>
V0225	Mechanical Malfunction Mention	0	No	<a href="#">more</a>
V0226	Case Vehicle And Object	4	Yes, fixed object off-road	<a href="#">more</a>
V0227	Case Vehicle Rollover	0	No	<a href="#">more</a>
V0228	Rollover Location	0	No rollover	<a href="#">more</a>
V0229	Roll Direction	0	No rollover	<a href="#">more</a>
V0230	Rollover Initiation Type	0	No rollover	<a href="#">more</a>
V0231	Rollover Number Of Turns	0	No rollover	<a href="#">more</a>
V0232	Case Vehicle Preimpact Braking	0	No	<a href="#">more</a>
V0233	Case Vehicle Preimpact Stability	1	Case vehicle tracking before impact	<a href="#">more</a>
V0234	Case Vehicle Ran Off Roadway	1	Yes	<a href="#">more</a>
V0235	Moving Case Vehicle Contacted Moving Vehicle	0	No	<a href="#">more</a>
V0236	Case Vehicle Contacted Stopped Vehicle	0	No	<a href="#">more</a>
V0237	Stopped Case Vehicle Contacted Vehicle	0	No	<a href="#">more</a>
V0238	Total Vehicles Hit By Case Vehicle	0	0 vehicles	<a href="#">more</a>
V0239	Any Fire In Crash?	0	No	<a href="#">more</a>
V0240	Maximum Police Severity-acc	2	B - Non-Incapacitating Injury	<a href="#">more</a>
V0241	Driver Alcohol Involvmnt	0	Had not been drinking	<a href="#">more</a>
V0242	Driver Alcohol BAC (Case Vehicle)	80	No test	<a href="#">more</a>
V0243	Driver Impairment Mention	0	No	<a href="#">more</a>

V0244	Driver Distraction	11	Sleepy or fell asleep	<a href="#">more</a>
V0245	Driver Drug Involvement	0	None	<a href="#">more</a>
V0246	Driver Drug Type	0	No drug use	<a href="#">more</a>
V0247	Driven/towed From Scene	2	Towed Due to Damage	<a href="#">more</a>

## Other Vehicle

[Back to Top](#)

Variable Number	Variable Name	Code Value	Code Description	Other Options
V0301	Other Vehicle VIN	0 xxxxxxx	<a href="#">Click for Contacted Vehicle figure</a>	<a href="#">more</a>
V0302	Other Vehicle Manufacturer/Body Code	99898	—	—
V0303	Other Vehicle Manufacturer	998	Unknown Other Vehicle	<a href="#">more</a>
V0304	Other Vehicle Body Code	98	No Other Vehicle	<a href="#">more</a>
V0305	Other Vehicle Make/model	0000	No other vehicle	<a href="#">more</a>
V0306	Other Vehicle Model Year	0000	No Other Vehicle	<a href="#">more</a>
V0307	Other Vehicle Mass	000000 kg	No Other Vehicle	<a href="#">more</a>
V0308	Other Vehicle Number	8	No other vehicle	<a href="#">more</a>
V0309	Other Vehicle Number of Occupants	98	No Other Vehicle	<a href="#">more</a>
V0310	Other Vehicle Traveling Speed	990	No Other Vehicle	<a href="#">more</a>
V0311	Highest Police Injury Severity	9	Unknown	<a href="#">more</a>
V0312	Other Vehicle Type	99	Unknown	<a href="#">more</a>
V0313	Other Vehicle Wheelbase in Centimeters	999	Unknown wheelbase	<a href="#">more</a>
V0314	Other Vehicle Average Track Width	999	Unknown	<a href="#">more</a>
V0315	Other Vehicle Overall Length	999	Unknown	<a href="#">more</a>
V0316	Other Vehicle Overall Width (OAW)	999	Unknown	<a href="#">more</a>
V0317	Other Vehicle Front Overhang	999	Unknown	<a href="#">more</a>
V0318	Other Vehicle Rear Overhang	999	Unknown	<a href="#">more</a>
V0319	Other Vehicle Undeformed End Width (UEW)	999	Unknown	<a href="#">more</a>
V0320	Other Vehicle Engine Displacement	9.9	Unknown	<a href="#">more</a>
	Other Vehicle Engine:			



V0321	Number of Cylinders	99	Unknown	<a href="#">more</a>
V0322	Other Vehicle Direct Damage Length (DDL)	999	Unknown	<a href="#">more</a>
V0323	Other Vehicle Front-End Overlap	99	Missing or Not applicable	<a href="#">more</a>
V0324	Other Vehicle - Vehicle Overlap	99	Missing or Not applicable	<a href="#">more</a>

## Case Vehicle General

[Back to Top](#)

Variable Number	Variable Name	Code Value	Code Description	Other Options
V0401	VIN	3N1AB41D6XXXXXXXX	<a href="#">Click for Case Vehicle figure</a>	<a href="#">more</a>
V0402	Manufacturer/Body Code	94527	—	—
V0403	Vehicle Manufacturer	945	Nissan (Mexico)	<a href="#">more</a>
V0404	Vehicle Body Code	27	Compact 100-104.9 in. wb.	<a href="#">more</a>
V0405	Make/model Code	1571	Sentra	<a href="#">more</a>
V0406	Model Year	1999	Model year	<a href="#">more</a>
V0407	Vehicle Mass	001077 kg	Mass (Kg)	<a href="#">more</a>
V0408	Odometer Reading	107192	—	—
V0409	Number of Occupants	01	1 occupant	<a href="#">more</a>
V0410	Traveling Speed	105 kph	Speed (km/h)	<a href="#">more</a>
V0411	Body Type	14	4-door sedan	<a href="#">more</a>
V0412	Stolen Vehicle	8	Not currently collected	<a href="#">more</a>
V0413	Body Structure	2	Unitized	<a href="#">more</a>
V0414	Transmission Type	1	Automatic	<a href="#">more</a>
V0415	Transmission Lever Location	2	Console	<a href="#">more</a>
V0416	Steering	1	Power	<a href="#">more</a>
V0417	Brakes	1	Power	<a href="#">more</a>
V0418	Brake Type	2	Disc - front wheels	<a href="#">more</a>
V0419	Adjustable Pedals?	0	No	<a href="#">more</a>
V0420	Brake Anti-lock Device	2	Four-wheel	<a href="#">more</a>
V0421	Air Conditioning in Vehicle	8	Not currently collected	<a href="#">more</a>
V0422	Drive Type	2	Front wheel	<a href="#">more</a>
V0423	Dual Rear Wheels	0	No	<a href="#">more</a>
V0424	Original Restraint System Type	3	Air bag	<a href="#">more</a>

V0425	Equipped With Roll Bar	0	No	<a href="#">more</a>
V0426	Roof Type	1	Solid	<a href="#">more</a>
V0427	Case Vehicle Wheelbase in Centimeters	254 cm	Actual Wheelbase	<a href="#">more</a>
V0428	Anti-lacerative Glass	8	Not Collected	<a href="#">more</a>
V0429	Case Vehicle average track Width	147 cm	actual measurement (cm)	<a href="#">more</a>
V0430	Case Vehicle Overall Length	436 cm	actual measurement (cm)	<a href="#">more</a>
V0431	Case Vehicle Overall Width (OAW)	169	actual measurement (cm)	<a href="#">more</a>
V0432	Case Vehicle Front Overhang	090 cm	actual measurement (cm)	<a href="#">more</a>
V0433	Case Vehicle Rear Overhang	092 cm	actual measurement (cm)	<a href="#">more</a>
V0434	Case Vehicle Undeformed End Width (UEW)	148 cm	actual measurement (cm)	<a href="#">more</a>
V0435	Case Vehicle Engine Displacement	1.6 l	Liters	<a href="#">more</a>
V0436	Case Vehicle Engine: Number of Cylinders	04	number of cylinders	<a href="#">more</a>
V0437	Case Vehicle Direct Damage Length (DDL)	148 cm	actual measurement (cm)	<a href="#">more</a>
V0438	Case Vehicle Front-end Overlap	98	98% or more	<a href="#">more</a>
V0439	Case Vehicle - Vehicle Overlap	98	98% or more	<a href="#">more</a>

### Case Vehicle Damage Description

[Back to Top](#)

Variable Number	Variable Name	Code Value	Code Description	Other Options
V0501	Maximum Sheet Metal Crush - Front	046 cm	Depth of Crush (cm)	<a href="#">more</a>
V0502	Maximum Sheet Metal Crush - Right Side	000 cm	No Crush (or less than 1 cm.)	<a href="#">more</a>
V0503	Maximum Sheet Metal Crush - Rear	000 cm	No Crush (or less than 1 cm.)	<a href="#">more</a>
V0504	Maximum Sheet Metal Crush - Left Side	000 cm	No Crush (or less than 1 cm.)	<a href="#">more</a>

V0505	Maximum Sheet Metal Crush - Roof	000 cm	No Crush (or less than 1 cm.)	<a href="#">more</a>
V0506	Maximum Sheet Metal Crush - Other	000 cm	No Crush (or less than 1 cm.)	<a href="#">more</a>
V0507	Seq In Chronological Ord	1	Yes	<a href="#">more</a>
V0508	Event 1 -impact Location	4	Outside Roadside right-of-way	<a href="#">more</a>
V0509	Event 1 -Impact Configuration	17	FRONT of case veh - object	<a href="#">more</a>
V0510	Event 1 -Object/Vehicle Contactd	91	Guard rail, middle section	<a href="#">more</a>
V0511	Event 2 -impact Location	8	No 2nd event	<a href="#">more</a>
V0512	Event 2 -Impact Configuration	88	No 2nd event	<a href="#">more</a>
V0513	Event 2 -Object/Vehicle Contactd	00	No object/vehicle contacted	<a href="#">more</a>
V0514	Event 3 -impact Location	8	No 3rd event	<a href="#">more</a>
V0515	Event 3 -Impact Configuration	88	No 3rd event	<a href="#">more</a>
V0516	Event 3 -Object/Vehicle Contactd	00	No object/vehicle contacted	<a href="#">more</a>
V0517	Event 4 -impact Location	8	No 4th event	<a href="#">more</a>
V0518	Event 4 -Impact Configuration	88	No 4th event	<a href="#">more</a>
V0519	Event 4 -Object/Vehicle Contactd	00	No object/vehicle contacted	<a href="#">more</a>
V0520	Event 5 -impact Location	8	No 5th event	<a href="#">more</a>
V0521	Event 5 -Impact Configuration	88	No 5th event	<a href="#">more</a>
V0522	Event 5 -Object/Vehicle Contactd	00	No object/vehicle contacted	<a href="#">more</a>
V0523	Event 6 -impact Location	8	No 6th event	<a href="#">more</a>
V0524	Event 6 -Impact Configuration	88	No 6th event	<a href="#">more</a>
V0525	Event 6 -Object/Vehicle Contactd	00	No object/vehicle contacted	<a href="#">more</a>
V0526	Event 7 -impact Location	8	No 7th event	<a href="#">more</a>
V0527	Event 7 -Impact Configuration	88	No 7th event	<a href="#">more</a>
V0528	Event 7 -Object/Vehicle Contactd	00	No object/vehicle contacted	<a href="#">more</a>
V0529	Primary CDC Case Vehicle - event Number	1	Event 1	<a href="#">more</a>

V0530	Primary CDC Case Vehicle - Impact Speed (kph)	999	Unknown	<a href="#">more</a>
V0531	Primary CDC Case Vehicle-estimatr	1	Investigator	<a href="#">more</a>
V0532	Primary CDC Case Vehicle - Crush (CM)	046	Crush measurements in cm	<a href="#">more</a>
V0533	Primary CDC Case Vehicle-clock #1	12	12 o'clock	<a href="#">more</a>
V0534	Primary CDC Case Vehicle-Letter 1 #1	06	F - Front	<a href="#">more</a>
V0535	Primary CDC Case Vehicle-Letter 2 #1	04	D - Distributed (Side or End)	<a href="#">more</a>
V0536	Primary CDC Case Vehicle-Letter 3 #1	05	E - Everything below belt line	<a href="#">more</a>
V0537	Primary CDC Case Vehicle-Letter 4 #1	23	W - Wide impact area	<a href="#">more</a>
V0538	Primary CDC Case Vehicle Extent #1	02	Extent 2	<a href="#">more</a>
V0539	Primary CDC - Contacted Vehicles Assoc CDC - CDC #1	12FDEW2	—	—
V0540	Primary CDC Case Vehicle-clock #2	98	Not Applicable	<a href="#">more</a>
V0541	Primary CDC Case Vehicle-Letter 1 #2	00	Missing Data/Not applicable	<a href="#">more</a>
V0542	Primary CDC Case Vehicle-Letter 2 #2	00	Missing Data/Not applicable	<a href="#">more</a>
V0543	Primary CDC Case Vehicle-Letter 3 #2	00	Missing Data/Not applicable	<a href="#">more</a>
V0544	Primary CDC Case Vehicle-Letter 4 #2	00	Missing Data/Not applicable	<a href="#">more</a>
V0545	Primary CDC Case Vehicle Extent #2	00	Missing Data/Not applicable	<a href="#">more</a>
V0546	Primary CDC - Case Vehicle Assoc CDC - CDC #2	9800000	—	—
V0547	Primary CDC Contacted Vehicle - Impact Speed (kph)	998	Not Applicable	<a href="#">more</a>
V0548	Primary CDC Contacted Vehicle-estimator	1	Investigator	<a href="#">more</a>
V0549	Primary CDC Contacted Vehicle - Crush (CM)	998	Not Applicable	<a href="#">more</a>
V0550	Primary CDC Contacted Vehicle-clock #1	98	Not Applicable	<a href="#">more</a>

V0551	Primary CDC Contacted Vehicle-Letter 1 #1	00	Missing Data/Not applicable	<a href="#">more</a>
V0552	Primary CDC Contacted Vehicle-Letter 2 #1	00	Missing Data/Not applicable	<a href="#">more</a>
V0553	Primary CDC Contacted Vehicle-Letter 3 #1	00	Missing Data/Not applicable	<a href="#">more</a>
V0554	Primary CDC Contacted Vehicle-Letter 4 #1	00	Missing Data/Not applicable	<a href="#">more</a>
V0555	Primary CDC Contacted Vehicle Extent #1	00	Missing Data/Not applicable	<a href="#">more</a>
V0556	primary CDC - Contacted Vehicles Assoc CDC - CDC #1	9800000	—	—
V0557	Primary CDC Contacted Vehicle-clock #2	98	Not Applicable	<a href="#">more</a>
V0558	Primary CDC Contacted Vehicle-Letter 1 #2	00	Missing Data/Not applicable	<a href="#">more</a>
V0559	Primary CDC Contacted Vehicle-Letter 2 #2	00	Missing Data/Not applicable	<a href="#">more</a>
V0560	Primary CDC Contacted Vehicle-Letter 3 #2	00	Missing Data/Not applicable	<a href="#">more</a>
V0561	Primary CDC Contacted Vehicle-Letter 4 #2	00	Missing Data/Not applicable	<a href="#">more</a>
V0562	Primary CDC Contacted Vehicle Extent #2	00	Missing Data/Not applicable	<a href="#">more</a>
V0563	Primary CDC - Contacted Vehicles Assoc CDC - CDC #2	9800000	—	—
V0564	Secondary CDC Case Vehicle-event No	8	Not applicable	<a href="#">more</a>
V0565	Secondary CDC Case Vehicle - Impact Speed (kph)	998	Not Applicable	<a href="#">more</a>
V0566	Secondary CDC Case Vehicle-estimator	8	Not applicable (no vehicle/no impact)	<a href="#">more</a>
V0567	Secondary CDC Case Vehicle - Crush (CM)	998	Not Applicable	<a href="#">more</a>
V0568	Secondary CDC Case Vehicle-clock #1	98	Not Applicable	<a href="#">more</a>
V0569	Secondary CDC Case Vehicle-Letter 1 #1	00	Missing Data/Not applicable	<a href="#">more</a>
V0570	Secondary CDC Case Vehicle-Letter 2 #1	00	Missing Data/Not applicable	<a href="#">more</a>
V0571	Secondary CDC Case Vehicle-Letter 3 #1	00	Missing Data/Not applicable	<a href="#">more</a>

V0572	Secondary CDC Case Vehicle-Letter 4 #1	00	Missing Data/Not applicable	<a href="#">more</a>
V0573	Secondary CDC Case Vehicle Extent #1	00	Missing Data/Not applicable	<a href="#">more</a>
V0574	Secondary CDC - Case Vehicle Assoc CDC - CDC #1	9800000	—	—
V0575	Secondary CDC Case Vehicle-clock #2	98	Not Applicable	<a href="#">more</a>
V0576	Secondary CDC Case Vehicle-Letter 1 #2	00	Missing Data/Not applicable	<a href="#">more</a>
V0577	Secondary CDC Case Vehicle-Letter 2 #2	00	Missing Data/Not applicable	<a href="#">more</a>
V0578	Secondary CDC Case Vehicle-Letter 3 #2	00	Missing Data/Not applicable	<a href="#">more</a>
V0579	Secondary CDC Case Vehicle-Letter 4 #2	00	Missing Data/Not applicable	<a href="#">more</a>
V0580	Secondary CDC Case Vehicle Extent #2	00	Missing Data/Not applicable	<a href="#">more</a>
V0581	Secondary CDC - Case Vehicle Assoc CDC - CDC #2	9800000	—	—
V0582	Secondary CDC Contacted Vehicle - Impact Speed (kph)	998	Not Applicable	<a href="#">more</a>
V0583	Secondary CDC Contacted Vehicle-estimator	8	Not applicable (no vehicle/no impact)	<a href="#">more</a>
V0584	Secondary CDC Contacted Vehicle - Crush (CM)	998	Not Applicable	<a href="#">more</a>
V0585	Secondary CDC Contacted Vehicle-clock #1	98	Not Applicable	<a href="#">more</a>
V0586	Secondary CDC Contacted Vehicle-Letter 1 #1	00	Missing Data/Not applicable	<a href="#">more</a>
V0587	Secondary CDC Contacted Vehicle-Letter 2 #1	00	Missing Data/Not applicable	<a href="#">more</a>
V0588	Secondary CDC Contacted Vehicle-Letter 3 #1	00	Missing Data/Not applicable	<a href="#">more</a>
V0589	Secondary CDC Contacted Vehicle-Letter 4 #1	00	Missing Data/Not applicable	<a href="#">more</a>
V0590	Secondary CDC Contacted Vehicle Extent #1	00	Missing Data/Not applicable	<a href="#">more</a>
V0591	Secondary CDC - Contacted Vehicle Assoc CDC - CDC #1	9800000	—	—
	Secondary CDC Contacted			

V0592	Vehicle-clock #2	98	Not Applicable	<a href="#">more</a>
V0593	Secondary CDC Contacted Vehicle-Letter 1 #2	00	Missing Data/Not applicable	<a href="#">more</a>
V0594	Secondary CDC Contacted Vehicle-Letter 2 #2	00	Missing Data/Not applicable	<a href="#">more</a>
V0595	Secondary CDC Contacted Vehicle-Letter 3 #2	00	Missing Data/Not applicable	<a href="#">more</a>
V0596	Secondary CDC Contacted Vehicle-Letter 4 #2	00	Missing Data/Not applicable	<a href="#">more</a>
V0597	Secondary CDC Contacted Vehicle Extent #2	00	Missing Data/Not applicable	<a href="#">more</a>
V0598	Secondary CDC - Contacted Vehicle Assoc CDC - CDC #2	9800000	—	—

## Crash Reconstruction

[Back to Top](#)

Variable Number	Variable Name	Code Value	Code Description	Other Options
V0601	Primary Delta-V Case Vehicle-event #	1	Event number 1	<a href="#">more</a>
V0602	Primary Delta V Case Vehicle - Total Delta V	043 kph	kph	<a href="#">more</a>
V0603	Primary delta-V Case Vehicle -LONGITUD	-043	—	—
V0604	Primary delta-V Case Vehicle-Lateral	0000	—	—
V0605	Primary Delta V Case Vehicle - Energy Dissipated by Crush (k	0976	—	—
V0606	Primary Delta-V Case Vehicle-Reconstruction	23	Reconstructed, high confidence level	<a href="#">more</a>
V0607	Primary Delta-V Case Vehicle- Mode	2	CDC & detailed damage	<a href="#">more</a>
V0608	Primary Delta V Contacted Vehicle - Total Delta V	888	Not Applicable	<a href="#">more</a>
V0609	Primary delta-V Contacted Vehicle-LONGITUD	8888	—	—
V0610	Primary delta-V Contacted Vehicle-Lateral	8888	—	—
V0611	Primary delta-V Contacted Vehicle - Energy Dissipated by Cru	8888	—	—

V0612	Secondary Delta-V Case Vehicle-event #	8	Not applicable	<a href="#">more</a>
V0613	Secondary Delta V Case Vehicle - Total Delta V	888	Not applicable	<a href="#">more</a>
V0614	Secondarydelta-V Case Vehicle -LONGITUD	8888	—	—
V0615	Secondary delta-V Case Vehicle-Lateral	8888	—	—
V0616	Secondary delta-V Case Vehicle - Energy Dissipated by Crush	8888	—	—
V0617	Secondary Delta-V Case Vehicle-Reconstruction	88	Not applicable	<a href="#">more</a>
V0618	Secondary Delta-V Case Vehicle- Mode	8	Not applicable	<a href="#">more</a>
V0619	Secondary Delta V Contacted Vehicle - Total Delta V	888	Not applicable	<a href="#">more</a>
V0620	Secondary delta-V Contacted Vehicle-LONGITUD	8888	—	—
V0621	Secondary delta-V Contacted Vehicle-Lateral	8888	—	—
V0622	Secondary delta-V Contacted Vehicle - Energy Dissipated By C	8888	—	—
V0623	Primary EBS Case Vehicle-event #	1	Event number 1	<a href="#">more</a>
V0624	Primary EBS Case Vehicle - Total EBS	043 kph	kph	<a href="#">more</a>
V0625	Primary EBS Case Vehicle - LONGITUD	-043	—	—
V0626	Primary EBS Case Vehicle-Lateral	0000	—	—
V0627	Primary EBS Case Vehicle - Energy Dissipated by Crush (kj)	0976	—	—
V0628	Primary EBS Case Vehicle-Reconstruction	23	Reconstructed, high confidence level	<a href="#">more</a>
V0629	Primary EBS Case Vehicle-Mode	2	CDC & detailed damage	<a href="#">more</a>
V0630	Primary EBS Contacted Vehicle - Total EBS	888	Not Applicable	<a href="#">more</a>
V0631	Primary EBS Contacted Vehicle-LONGITUD	8888	—	—
	Primary EBS Contacted			



V0632	Vehicle-Lateral	8888	—	—
V0633	Primary EBS Contact Vehicle - Energy Dissipated by Crush (kj)	8888	—	—
V0634	Secondary EBS Case Vehicle-event #	8	Not applicable	<a href="#">more</a>
V0635	Secondary EBS Case Vehicle - Total EBS	888	Not Applicable	<a href="#">more</a>
V0636	Secondary EBS Case Vehicle -LONGITUD	8888	—	—
V0637	Secondary EBS Case Vehicle-Lateral	8888	—	—
V0638	Secondary EBS Case Vehicle - Energy Dissipated by Crush (kj)	8888	—	—
V0639	Secondary EBS Case Vehicle-Reconstruction	88	Not applicable	<a href="#">more</a>
V0640	Secondary EBS Case Vehicle- Mode	8	Not applicable	<a href="#">more</a>
V0641	Secondary EBS Contacted Vehicle - Total EBS	888	Not Applicable	<a href="#">more</a>
V0642	Secondary EBS Contacted Vehicle-LONGITUD	8888	—	—
V0643	Secondary EBS Contacted Vehicle-Lateral	8888	—	—
V0644	Secondary EBS Contact Vehicle - Energy Dissipated by Crush (	8888	—	—
V0645	Specific Event # Case(1)	1	Event number 1	<a href="#">more</a>
V0646	Plane of Impact Case Vehicle (1)	1	Bumper	<a href="#">more</a>
V0647	Direct Damage Length (DDL) - Case Vehicle (1)	148 cm	cm	<a href="#">more</a>
V0648	Direct Damage Maximum Crush - Case Vehicle (1)	046 cm	cm	<a href="#">more</a>
V0649	Direct and Induced Damage Length in CM	106 cm	cm	<a href="#">more</a>
V0650	Field C1 - Case Vehicle (1)	037 cm	cm	<a href="#">more</a>
V0651	Field C2 - Case Vehicle (1)	040 cm	cm	<a href="#">more</a>
V0652	Field C3 - Case Vehicle (1)	042 cm	cm	<a href="#">more</a>
V0653	Field C4 - Case Vehicle (1)	046 cm	cm	<a href="#">more</a>
V0654	Field C5 - Case Vehicle (1)	039 cm	cm	<a href="#">more</a>
V0655	Field C6 - Case Vehicle (1)	027 cm	cm	<a href="#">more</a>

V0656	Direct Damage D Value = The Center of Direct Damage Offset t	+000 cm	Offset (cm)	<a href="#">more</a>
V0657	Specific Event # Case(2)	1	Event number 1	<a href="#">more</a>
V0658	Plane of Impact Case Vehicle (2)	1	Bumper	<a href="#">more</a>
V0659	Direct Damage Length (DDL) - Case Vehicle (2)	148 cm	cm	<a href="#">more</a>
V0660	Direct Damage MaximumCrush - Case Vehicle (2)	046 cm	cm	<a href="#">more</a>
V0661	Direct and Induced Damage Length in CM	106 cm	cm	<a href="#">more</a>
V0662	Field C1 - Case Vehicle (2)	037 cm	cm	<a href="#">more</a>
V0663	Field C2 - Case Vehicle (2)	040 cm	cm	<a href="#">more</a>
V0664	Field C3 - Case Vehicle (2)	042 cm	cm	<a href="#">more</a>
V0665	Field C4 - Case Vehicle (2)	046 cm	cm	<a href="#">more</a>
V0666	Field C5 - Case Vehicle (2)	039 cm	cm	<a href="#">more</a>
V0667	Field C6 - Case Vehicle (2)	027 cm	cm	<a href="#">more</a>
V0668	Direct Damage D Value = The Center of Direct Damage Offset t	+000 cm	cm	<a href="#">more</a>
V0669	Specific Event # Cont(1)	9	Unknown	<a href="#">more</a>
V0670	Plane of Impact Contacted Vehicle(1)	9	Unknown	<a href="#">more</a>
V0671	Direct Damage Length (DDL) - Contacted Vehicle (1)	999	Unknown	<a href="#">more</a>
V0672	Direct Damage Maximum Crush - Contacted Vehicle (1)	999	Unknown	<a href="#">more</a>
V0673	Field L - Contacted Vehicle (1)	999	Unknown	<a href="#">more</a>
V0674	Field C1 - Contacted Vehicle (1)	999	Unknown	<a href="#">more</a>
V0675	Field C2 - Contacted Vehicle (1)	999	Unknown	<a href="#">more</a>
V0676	Field C3 - Contacted Vehicle (1)	999	Unknown	<a href="#">more</a>
V0677	Field C4 - Contacted Vehicle (1)	999	Unknown	<a href="#">more</a>
V0678	Field C5 - Contacted Vehicle (1)	999	Unknown	<a href="#">more</a>

V0679	Field C6 - Contacted Vehicle (1)	999	Unknown	<a href="#">more</a>
V0680	Direct Damage D Value = The Center of Direct Damage Offset t	9999	offset (cm)	<a href="#">more</a>
V0681	Specific Event # Contacted Vehicle (2)	9	Unknown	<a href="#">more</a>
V0682	Plane of Impact Contacted Vehicle(2)	9	Unknown	<a href="#">more</a>
V0683	Direct Damage Length (DDL) - Contacted Vehicle (2)	999	Unknown	<a href="#">more</a>
V0684	Direct Damage Maximum Crush - Contacted Vehicle (2)	999	Unknown	<a href="#">more</a>
V0685	Direct and Induced Damage Length in CM	999	Unknown	<a href="#">more</a>
V0686	Field C1 - Contacted Vehicle (2)	999	Unknown	<a href="#">more</a>
V0687	Field C2 - Contacted Vehicle (2)	999	Unknown	<a href="#">more</a>
V0688	Field C3 - Contacted Vehicle (2)	999	Unknown	<a href="#">more</a>
V0689	Field C4 - Contacted Vehicle (2)	999	Unknown	<a href="#">more</a>
V0690	Field C5 - Contacted Vehicle (2)	999	Unknown	<a href="#">more</a>
V0691	Field C6 - Contacted Vehicle (2)	999	Unknown	<a href="#">more</a>
V0692	Direct Damage D Value = The Center of Direct Damage Offset t	9999	Offset (cm)	<a href="#">more</a>

## Case Vehicle Tires & Rims

[Back to Top](#)

Variable Number	Variable Name	Code Value	Code Description	Other Options
V0701	Left Front Wheel Damaged	1	Yes	<a href="#">more</a>
V0702	Right Front Wheel Damaged	1	Yes	<a href="#">more</a>
V0703	Right Rear Wheel Damaged	0	No	<a href="#">more</a>
V0704	Left Rear Wheel Damaged	0	No	<a href="#">more</a>
V0705	Left Front Tire Tread Type	4	All Weather	<a href="#">more</a>
V0706	Right Front Tire Tread Type	4	All Weather	<a href="#">more</a>

V0707	Right Rear Tire Tread Type	4	All Weather	<a href="#">more</a>
V0708	Left Rear Tire Tread Type	4	All Weather	<a href="#">more</a>
V0709	Left Front Carcass Construction	3	Radial	<a href="#">more</a>
V0710	Right Front Carcass Construction	3	Radial	<a href="#">more</a>
V0711	Right Rear Carcass Construction	3	Radial	<a href="#">more</a>
V0712	Left Rear Carcass Construction	3	Radial	<a href="#">more</a>
V0713	Left Front Tire Condition Precrash	0	Normal - no pre-crash problems	<a href="#">more</a>
V0714	Right Front Tire Condition Precrash	0	Normal - no pre-crash problems	<a href="#">more</a>
V0715	Right Rear Tire Condition Precrash	0	Normal - no pre-crash problems	<a href="#">more</a>
V0716	Left Rear Tire Condition Precrash	0	Normal - no pre-crash problems	<a href="#">more</a>
V0717	Left Front Tire Condition Postcrash	0	Normal - no damage to tire	<a href="#">more</a>
V0718	Right Front Tire Condition Postcrash	0	Normal - no damage to tire	<a href="#">more</a>
V0719	Right Rear Tire Condition Postcrash	0	Normal - no damage to tire	<a href="#">more</a>
V0720	Left Rear Tire Condition Postcrash	0	Normal - no damage to tire	<a href="#">more</a>
V0721	Left Front Tire Involvement	0	No	<a href="#">more</a>
V0722	Right Front Tire Involvement	0	No	<a href="#">more</a>
V0723	Right Rear Tire Involvement	0	No	<a href="#">more</a>
V0724	Left Rear Tire Involvement	0	No	<a href="#">more</a>
V0725	Left Front Tire Size	P18565R14	—	—
V0726	Right Front Tire Size	P18565R14	—	—
V0727	Right Rear Tire Size	P18565R14	—	—
V0728	Left Rear Tire Size	P18565R14	—	—
V0729	Left Front Tire Pressure (recorded in psi)	00.0 psi	Actual tire pressure in psi	<a href="#">more</a>
V0730	Right Front Tire Pressure (recorded in psi)	24.5 psi	Actual tire pressure in psi	<a href="#">more</a>
V0731	Right Rear Tire Pressure (recorded in psi)	11.5 psi	Actual tire pressure in psi	<a href="#">more</a>
	Left Rear Tire Pressure			

V0732	(recorded in psi)	24.5 psi	Actual tire pressure in psi	<a href="#">more</a>
V0733	Left Front Tread Depth	07	07/32"	<a href="#">more</a>
V0734	Right Front Tread Depth	07	07/32"	<a href="#">more</a>
V0735	Right Rear Tread Depth	07	07/32"	<a href="#">more</a>
V0736	Left Rear Tread Depth	07	07/32"	<a href="#">more</a>

### Case Vehicle Fuel Tank

[Back to Top](#)

Variable Number	Variable Name	Code Value	Code Description	Other Options
V0801	Propulsive Fuel Type	1	Gasoline	<a href="#">more</a>
V0802	Main Tank Location	322	Within frame/centered laterally - within vertical	<a href="#">more</a>
V0803	Main Filler Cap Location	113	Left of frame laterally - above vertically	<a href="#">more</a>
V0804	Main Tank Material	9	Unknown	<a href="#">more</a>
V0805	Aux Tank Type	8	Not applicable (not equipped)	<a href="#">more</a>
V0806	Aux Tank Location	888	Not applicable (not equipped)	<a href="#">more</a>
V0807	Aux Filler Cap Location	888	Not applicable (not equipped)	<a href="#">more</a>
V0808	Aux Tank Material	8	Not applicable	<a href="#">more</a>

### Case Vehicle Fuel Leakage

[Back to Top](#)

Variable Number	Variable Name	Code Value	Code Description	Other Options
V0901	Fuel Leakage From Crash	0	No	<a href="#">more</a>

### Case Vehicle Fire

[Back to Top](#)

Variable Number	Variable Name	Code Value	Code Description	Other Options
V1001	Fire In Or On Case Vehicle	0	No	<a href="#">more</a>

### Case Vehicle Exterior

[Back to Top](#)

Variable Number	Variable Name	Code Value	Code Description	Other Options
V1101	Hood Latch Released	1	Yes	<a href="#">more</a>
V1102	Hood Latch Damaged	1	Yes	<a href="#">more</a>
		0		

V1103	Hood Latch Jammed		No	<a href="#">more</a>
V1104	Left Hood Hinge Damaged	1	Yes	<a href="#">more</a>
V1105	Left Hood Hinge Separated	0	No	<a href="#">more</a>
V1106	Right Hood Hinge Damaged	1	Yes	<a href="#">more</a>
V1107	Right Hood Hinge Separated	0	No	<a href="#">more</a>
V1108	Hood Remained On Vehicle	1	Yes	<a href="#">more</a>
V1109	Rear Hood Edge Elevated	1	Yes	<a href="#">more</a>
V1110	Edge Contacted Windshield	1	Yes	<a href="#">more</a>
V1111	Edge Penetrated Windshield	0	No	<a href="#">more</a>
V1112	Hood Latch Location	1	Front of Vehicle	<a href="#">more</a>
V1113	Eng/transmissn Mount Separated	0	No	<a href="#">more</a>
V1114	Steering Column Flex Couplng	9	Unknown if equipped	<a href="#">more</a>
V1115	Steering Column Coupling Dam	9	Unknown	<a href="#">more</a>
V1116	Steering Column Coupling Separated	9	Unknown	<a href="#">more</a>
V1117	Eng Comp Telescopng Unit	88	Not currently collected	<a href="#">more</a>
V1118	Compartment Unit's Original/telescoped Length Difference	888	Not currently collected	<a href="#">more</a>
V1119	Left Side Body Mount Separated	8	Not applicable (unitized)	<a href="#">more</a>
V1120	Upper Left A-pillar Sep	0	No	<a href="#">more</a>
V1121	Lower Left A-pillar Sep	0	No	<a href="#">more</a>
V1122	Upper Left B-pillar Sep	0	No	<a href="#">more</a>
V1123	Lower Left B-pillar Sep	0	No	<a href="#">more</a>
V1124	Upper Left C-pillar Sep	0	No	<a href="#">more</a>
V1125	Lower Left C-pillar Sep	0	No	<a href="#">more</a>
V1126	Upper Left D-pillar Sep	8	Not applicable (not equipped)	<a href="#">more</a>
V1127	Lower Left D-pillar Sep	8	Not applicable (not equipped)	<a href="#">more</a>
V1128	Left Front Door Opening Cause	00	Door did not open	<a href="#">more</a>
V1129	Left Rear Door Opening Cause	00	Door did not open	<a href="#">more</a>
V1130	Left Front Door Jammed Closed	0	No	<a href="#">more</a>
V1131	Left Rear Door Jammed Closed	0	No	<a href="#">more</a>
V1132	Van Left Rear Door Type	8	Not applicable (not a van)	<a href="#">more</a>

V1133	Left Front Glazing Availability	2	Closed	<a href="#">more</a>
V1134	Left Rear Glazing Availability	2	Closed	<a href="#">more</a>
V1135	Lr2 Glazing Availability	1	Fixed	<a href="#">more</a>
V1136	Left Front Glazing Damage	0	No damage	<a href="#">more</a>
V1137	Left Rear Glazing Damage	0	No damage	<a href="#">more</a>
V1138	Lr2 Glazing Damage	0	No damage	<a href="#">more</a>
V1139	Rear Door Type	0	No door (includes pickups)	<a href="#">more</a>
V1140	Rear Door Opening Cause	8	Not applicable (no rear door)	<a href="#">more</a>
V1141	Rear Door Jammed Closed	8	Not applicable (no rear door)	<a href="#">more</a>
V1142	Rear Glazng Availability	8	Not Applicable (No Door)	<a href="#">more</a>
V1143	Rear Glazing Damage	8	Not Applicable (No Door)	<a href="#">more</a>
V1144	Luggage Partition Damaged	8	Not applicable	<a href="#">more</a>
V1145	Spare Tire Status	8	Not collected	<a href="#">more</a>
V1146	Trailer Hitch Type	0	No hitch	<a href="#">more</a>
V1147	Trailer Type	0	No trailer	<a href="#">more</a>
V1148	Rght Side Body Mount Separated	8	Not applicable (unitized)	<a href="#">more</a>
V1149	Upper Right A-pillar Separated	0	No	<a href="#">more</a>
V1150	Lower Right A-pillar Separated	0	No	<a href="#">more</a>
V1151	Upper Right B-pillar Separated	0	No	<a href="#">more</a>
V1152	Lower Right B-pillar Separated	0	No	<a href="#">more</a>
V1153	Upper Right C-pillar Separated	0	No	<a href="#">more</a>
V1154	Lower Right C-pillar Separated	0	No	<a href="#">more</a>
V1155	Upper Right D-pillar Separated	8	Not applicable (not equipped)	<a href="#">more</a>
V1156	Lower Right D-pillar Separated	8	Not applicable (not equipped)	<a href="#">more</a>
V1157	Right Front Door Opening Cause	00	Door did not open	<a href="#">more</a>
V1158	Right Rear Door Opening Cause	00	Door did not open	<a href="#">more</a>
V1159	Right Front Door Jammed Closed	0	No	<a href="#">more</a>

V1160	Right Rear Door Jammed Closed	0	No	<a href="#">more</a>
V1161	Van Right-rear Door Type	8	Not applicable (not a van)	<a href="#">more</a>
V1162	Right Front Glazing Availability	2	Closed	<a href="#">more</a>
V1163	Right Rear Glazing Availability	2	Closed	<a href="#">more</a>
V1164	Rr2 Glazing Availability	1	Fixed	<a href="#">more</a>
V1165	Right Front Glazing Damage	0	No damage	<a href="#">more</a>
V1166	Right Rear Glazing Damage	0	No damage	<a href="#">more</a>
V1167	Rr2 Glazing Damage	0	No damage	<a href="#">more</a>
V1168	Windshield Cracked	1	Yes	<a href="#">more</a>
V1169	Windshield Broken	0	No <a href="#">Click for Windshield Damage figure</a>	<a href="#">more</a>
V1170	Occupant Cracked/Broke Wndshld	0	No	<a href="#">more</a>
V1171	Bond Separation Extent	0	None	<a href="#">more</a>
V1172	Windshield Code	97	<a href="#">Click for Windshield Mark figure</a>	<a href="#">more</a>
V1173	Did Sun Roof/T-Roof Open	8	Not Applicable	<a href="#">more</a>

### Case Vehicle Steering Column/Rim

[Back to Top](#)

Variable Number	Variable Name	Code Value	Code Description	Other Options
V1201	Steering Wheel Rim Damage	0	None	<a href="#">more</a>
V1202	Number of Steering Wheel Spokes	4	4 spokes	<a href="#">more</a>
V1203	Steering Wheel Spoke Damage	0	None	<a href="#">more</a>
V1204	Steering Wheel Hub Damage	0	None	<a href="#">more</a>
V1205	Steering Wheel Location of Rim Damage	0	No damage	<a href="#">more</a>
V1206	Aftermarket Add-on Device	0	None	<a href="#">more</a>
V1207	Column Tilt Feature	1	Yes, equipped	<a href="#">more</a>
V1208	Column Swing-away Feature	0	Not equipped	<a href="#">more</a>
V1209	Column Telescoping Feature	0	Not equipped	<a href="#">more</a>
V1210	Wheel Energy Absorb Device	8	Not currently collected	<a href="#">more</a>
V1211	Wheel EA Device's original/damage Dimension Difference	888	Not collected	<a href="#">more</a>



V1212	Column Energy Absorb Device	88	Not collected	<a href="#">more</a>
V1213	Col EA Device's Orig/compressed (or Extruded) Length Diff	888	Not collected	<a href="#">more</a>
V1214	Shear Capsule Separation	888	Not collected	<a href="#">more</a>
V1215	Column Vertical Rotation	0	No apparent rotation	<a href="#">more</a>
V1216	Column Lateral Rotation	0	No apparent rotation	<a href="#">more</a>

## Case Vehicle Intrusion

[Back to Top](#)

Variable Number	Variable Name	Code Value	Code Description	Other Options
V1301	Was Occupant Compartment Intruded	1	Yes <a href="#">Click for Intrusion figure</a>	<a href="#">more</a>
V1302	Was Intrusn Catastrophic	0	No	<a href="#">more</a>
V1303	Intrusion #1	01	Intrusion Number	<a href="#">more</a>
V1304	Occupant Space Number(1)	11	First row, Left seat	<a href="#">more</a>
V1305	Intrud Component/obj (1)	03	Toe pan	<a href="#">more</a>
V1306	Associate Event Numb (1)	1	Event #1	<a href="#">more</a>
V1307	Maximum Intrusion X Axis	08 cm	Intrusion (cm)	<a href="#">more</a>
V1308	Maximum Intrusion Y Axis	00 cm	0 cm or No Intrusion	<a href="#">more</a>
V1309	Maximum Intrusion Z Axis	00 cm	0 cm or No Intrusion	<a href="#">more</a>
V1310	Occupant Number #1 (1)	00	No contact or no intrusion	<a href="#">more</a>
V1311	Injury #1 (1)	00	No injury or no intrusion	<a href="#">more</a>
V1312	Occupant Number #2 (1)	00	No contact or no intrusion	<a href="#">more</a>
V1313	Injury #2 (1)	00	No injury or no intrusion	<a href="#">more</a>
V1314	Intrusion Number #2	02	Intrusion #2	<a href="#">more</a>
V1315	Occupant Space Number(2)	11	First row, Left seat	<a href="#">more</a>
V1316	Intrud Component/obj (2)	04	Floor pan	<a href="#">more</a>
V1317	Associate Event Numb (2)	1	Event #1	<a href="#">more</a>
V1318	Maximum Intrusion X Axis	00 cm	0 cm or No Intrusion	<a href="#">more</a>
V1319	Maximum Intrusion Y Axis	00 cm	0 cm or No Intrusion	<a href="#">more</a>
V1320	Maximum Intrusion Z Axis	05 cm	Intrusion (cm)	<a href="#">more</a>
V1321	Occupant Number #1 (2)	00	No contact or no intrusion	<a href="#">more</a>
V1322	Injury #1 (2)	00	No injury or no intrusion	<a href="#">more</a>
V1323	Occupant Number #2 (2)	00	No contact or no intrusion	<a href="#">more</a>
V1324	Injury Number #2 (2)	00	No injury or no intrusion	<a href="#">more</a>
V1325	Intrusion Number #3	03	Intrusion #3	<a href="#">more</a>

V1326	Occupant Space Number(3)	13	First row, Right seat	<a href="#">more</a>
V1327	Intrud Component/obj (3)	03	Toe pan	<a href="#">more</a>
V1328	Associate Event Numb (3)	1	Event #1	<a href="#">more</a>
V1329	Maximum Intrusion X Axis	07 cm	Intrusion (cm)	<a href="#">more</a>
V1330	Maximum Intrusion Y Axis	00 cm	0 cm or No Intrusion	<a href="#">more</a>
V1331	Maximum Intrusion Z Axis	00 cm	0 cm or No Intrusion	<a href="#">more</a>
V1332	Occupant Number #1 (3)	00	No contact or no intrusion	<a href="#">more</a>
V1333	Injury #1 (3)	00	No injury or no intrusion	<a href="#">more</a>
V1334	Occupant Number #2 (3)	00	No contact or no intrusion	<a href="#">more</a>
V1335	Injury Number #2 (3)	00	No injury or no intrusion	<a href="#">more</a>
V1336	Intrusion Number #4	04	Intrusion #4	<a href="#">more</a>
V1337	Occupant Space Number(4)	13	First row, Right seat	<a href="#">more</a>
V1338	Intrud Component/obj (4)	04	Floor pan	<a href="#">more</a>
V1339	Associate Event Numb (4)	1	Event #1	<a href="#">more</a>
V1340	Maximum Intrusion X Axis	00 cm	0 cm or No Intrusion	<a href="#">more</a>
V1341	Maximum Intrusion Y Axis	00 cm	0 cm or No Intrusion	<a href="#">more</a>
V1342	Maximum Intrusion Z Axis	03 cm	Intrusion (cm)	<a href="#">more</a>
V1343	Occupant Number #1 (4)	00	No contact or no intrusion	<a href="#">more</a>
V1344	Injury #1 (4)	00	No injury or no intrusion	<a href="#">more</a>
V1345	Occupant Number #2 (4)	00	No contact or no intrusion	<a href="#">more</a>
V1346	Injury Number #2 (4)	00	No injury or no intrusion	<a href="#">more</a>
V1347	Intrusion Number #5	99	Unknown or data not collected	<a href="#">more</a>
V1348	Occupant Space Number(5)	99	Unknown or data not collected	<a href="#">more</a>
V1349	Intrud Component/obj (5)	99	Unknown or data not collected	<a href="#">more</a>
V1350	Associate Event Numb (5)	9	Unknown or data not collected	<a href="#">more</a>
V1351	Maximum Intrusion X Axis	99	Unknown or data not collected	<a href="#">more</a>
V1352	Maximum Intrusion Y Axis	99	Unknown or data not collected	<a href="#">more</a>
V1353	Maximum Intrusion Z Axis	99	Unknown or data not collected	<a href="#">more</a>
V1354	Occupant Number #1 (5)	99	Unknown or data not collected	<a href="#">more</a>
V1355	Injury #1 (5)	99	Contact, injury unknown or data not collected	<a href="#">more</a>
V1356	Occupant Number #2 (5)	99	Unknown or data not collected	<a href="#">more</a>
V1357	Injury Number #2 (5)	99	Contact, injury unknown or data not collected	<a href="#">more</a>
V1358	Intrusion Number #6	99	Unknown or data not collected	<a href="#">more</a>
V1359	Occupant Space Number(6)	99	Unknown or data not collected	<a href="#">more</a>
V1360	Intrud Component/obj (6)	99	Unknown or data not collected	<a href="#">more</a>
V1361	Associate Event Numb (6)	9	Unknown or data not collected	<a href="#">more</a>

V1362	Maximum Intrusion X Axis	99	Unknown or data not collected	<a href="#">more</a>
V1363	Maximum Intrusion Y Axis	99	Unknown or data not collected	<a href="#">more</a>
V1364	Maximum Intrusion Z Axis	99	Unknown or data not collected	<a href="#">more</a>
V1365	Occupant Number #1 (6)	99	Unknown or data not collected	<a href="#">more</a>
V1366	Injury #1 (6)	99	Contact, injury unknown or data not collected	<a href="#">more</a>
V1367	Occupant Number #2 (6)	99	Unknown or data not collected	<a href="#">more</a>
V1368	Injury Number #2 (6)	99	Contact, injury unknown or data not collected	<a href="#">more</a>
V1369	Intrusion Number #7	99	Unknown or data not collected	<a href="#">more</a>
V1370	Occupant Space Number(7)	99	Unknown or data not collected	<a href="#">more</a>
V1371	Intrud Component/obj (7)	99	Unknown or data not collected	<a href="#">more</a>
V1372	Associate Event Numb (7)	9	Unknown or data not collected	<a href="#">more</a>
V1373	Maximum Intrusion X Axis	99	Unknown or data not collected	<a href="#">more</a>
V1374	Maximum Intrusion Y Axis	99	Unknown or data not collected	<a href="#">more</a>
V1375	Maximum Intrusion Z Axis	99	Unknown or data not collected	<a href="#">more</a>
V1376	Occupant Number #1 (7)	99	Unknown or data not collected	<a href="#">more</a>
V1377	Injury #1 (7)	99	Contact, injury unknown or data not collected	<a href="#">more</a>
V1378	Occupant Number #2 (7)	99	Unknown or data not collected	<a href="#">more</a>
V1379	Injury Number #2 (7)	99	Contact, injury unknown or data not collected	<a href="#">more</a>
V1380	Intrusion Number #8	99	Unknown or data not collected	<a href="#">more</a>
V1381	Occupant Space Number(8)	99	Unknown or data not collected	<a href="#">more</a>
V1382	Intrud Component/obj (8)	99	Unknown or data not collected	<a href="#">more</a>
V1383	Associate Event Numb (8)	9	Unknown or data not collected	<a href="#">more</a>
V1384	Maximum Intrusion X Axis	99	Unknown or data not collected	<a href="#">more</a>
V1385	Maximum Intrusion Y Axis	99	Unknown or data not collected	<a href="#">more</a>
V1386	Maximum Intrusion Z Axis	99	Unknown or data not collected	<a href="#">more</a>
V1387	Occupant Number #1 (8)	99	Unknown or data not collected	<a href="#">more</a>
V1388	Injury #1 (8)	99	Contact, injury unknown or data not collected	<a href="#">more</a>
V1389	Occupant Number #2 (8)	99	Unknown or data not collected	<a href="#">more</a>
V1390	Injury #2 (8)	99	Contact, injury unknown or data not collected	<a href="#">more</a>
V1391	Intrusion Number #9	99	Unknown or data not collected	<a href="#">more</a>
V1392	Occupant Space Number(9)	99	Unknown or data not collected	<a href="#">more</a>
V1393	Intrud Component/obj (9)	99	Unknown or data not collected	<a href="#">more</a>
V1394	Associate Event Numb (9)	9	Unknown or data not collected	<a href="#">more</a>

V1395	Maximum Intrusion X Axis	99	Unknown or data not collected	<a href="#">more</a>
V1396	Maximum Intrusion Y Axis	99	Unknown or data not collected	<a href="#">more</a>
V1397	Maximum Intrusion Z Axis	99	Unknown or data not collected	<a href="#">more</a>
V1398	Occupant Number #1 (9)	99	Unknown or data not collected	<a href="#">more</a>
V1399	Injury #1 (9)	99	Contact, injury unknown or data not collected	<a href="#">more</a>
V1400	Occupant Number #2 (9)	99	Unknown or data not collected	<a href="#">more</a>
V1401	Injury Number #2 (9)	99	Contact, injury unknown or data not collected	<a href="#">more</a>
V1402	Intrusion Number #10	99	Unknown or data not collected	<a href="#">more</a>
V1403	Occupant Space Number (10)	99	Unknown or data not collected	<a href="#">more</a>
V1404	Intrud Component/obj(10)	99	Unknown or data not collected	<a href="#">more</a>
V1405	Associate Event Numb(10)	9	Unknown or data not collected	<a href="#">more</a>
V1406	Maximum Intrusion X Axis	99	Unknown or data not collected	<a href="#">more</a>
V1407	Maximum Intrusion Y Axis	99	Unknown or data not collected	<a href="#">more</a>
V1408	Maximum Intrusion Z Axis	99	Unknown or data not collected	<a href="#">more</a>
V1409	Occupant Number #1 (10)	99	Unknown or data not collected	<a href="#">more</a>
V1410	Injury #1 (10)	99	Contact, injury unknown or data not collected	<a href="#">more</a>
V1411	Occupant Number #2 (10)	99	Unknown or data not collected	<a href="#">more</a>
V1412	Injury Number #2 (10)	99	Contact, injury unknown or data not collected	<a href="#">more</a>
V1413	Intrusion Number (a)	88	Not Applicable	<a href="#">more</a>
V1414	Cause Of Intrusion (a)	8	Not applicable	<a href="#">more</a>
V1415	Intrusion Number (b)	88	Not Applicable	<a href="#">more</a>
V1416	Cause Of Intrusion (b)	8	Not applicable	<a href="#">more</a>
V1417	Intrusion Number (c)	88	Not Applicable	<a href="#">more</a>
V1418	Cause Of Intrusion (c)	8	Not applicable	<a href="#">more</a>
V1419	Intrusion Number (a)	88	Not Applicable	<a href="#">more</a>
V1420	Damaged Component 1 (a)	8	Not Applicable	<a href="#">more</a>
V1421	Damaged Component 2 (a)	8	Not Applicable	<a href="#">more</a>
V1422	Intrusion Number (b)	88	Not Applicable	<a href="#">more</a>
V1423	Damaged Component 1 (b)	8	Not Applicable	<a href="#">more</a>
V1424	Damaged Component 2 (b)	8	Not Applicable	<a href="#">more</a>
V1425	Intrusion Number (c)	88	Not Applicable	<a href="#">more</a>
V1426	Damaged Component 1 (c)	8	Not Applicable	<a href="#">more</a>
V1427	Damaged Component 2 (c)	8	Not Applicable	<a href="#">more</a>
V1428	Intrusion Number (d)	88	Not Applicable	<a href="#">more</a>
V1429	Damaged Component 1 (d)	8	Not Applicable	<a href="#">more</a>

V1430	Damaged Component 2 (d)	8	Not Applicable	<a href="#">more</a>
-------	-------------------------	---	----------------	----------------------

## Case Vehicle Airbag(s)

[Back to Top](#)

Variable Number	Variable Name	Code Value	Code Description	Other Options
V1501	Driver Airbag Equipped	1	Yes <a href="#">Click for Driver Airbag figure</a>	<a href="#">more</a>
V1502	Right Front Airbag Equip	1	Yes <a href="#">Click for Passenger Airbag figure</a>	<a href="#">more</a>
V1503	Left Rear Airbag Equipped	0	No	<a href="#">more</a>
V1504	Right Rear Airbag Equipped	0	No	<a href="#">more</a>
V1505	Driver Airbag Deployed	1	Yes	<a href="#">more</a>
V1506	Rght Front Airbag Deploy	1	Yes	<a href="#">more</a>
V1507	Left Rear Airbag Deploy	8	Not applicable (no airbag)	<a href="#">more</a>
V1508	Rught Rear Airbag Deploy	8	Not applicable (no airbag)	<a href="#">more</a>
V1509	Driver On/off Switch	0	Not equipped (no switch)	<a href="#">more</a>
V1510	Rght Front On/off Switch	0	Not equipped (no switch)	<a href="#">more</a>
V1511	Left Rear On/off Switch	8	Not applicable (no airbag)	<a href="#">more</a>
V1512	Right Rear On/off Switch	8	Not applicable (no airbag)	<a href="#">more</a>
V1513	Driver Airbag Location	1	Steering wheel	<a href="#">more</a>
V1514	Right Front Airbag Location	2	Top instrument panel	<a href="#">more</a>
V1515	Left Rear Airbag Location	0	No airbag	<a href="#">more</a>
V1516	Right Rear Airbag Location	0	No airbag	<a href="#">more</a>
V1517	Driver Airbag Condition	0	No damage	<a href="#">more</a>
V1518	Right Front Airbag Condition	0	No damage	<a href="#">more</a>
V1519	Left Rear Airbag Condition	8	Not applicable (not equipped / not deployed)	<a href="#">more</a>
V1520	Right Rear Airbag Condition	8	Not applicable (not equipped / not deployed)	<a href="#">more</a>
V1521	Driver Airbag Tether	1	Yes	<a href="#">more</a>
V1522	Right Front Airbag Tether	0	No	<a href="#">more</a>
V1523	Left Rear Airbag Tether	8	Not applicable	<a href="#">more</a>
V1524	Right Rear Airbag Tether	8	Not applicable	<a href="#">more</a>
V1525	Driver Marked By Contact	1	Yes	<a href="#">more</a>
V1526	Right Front Marked By Contact	0	No	<a href="#">more</a>
V1527	Left Rear Marked By Contact	8	Not applicable (no airbag / not deployed)	<a href="#">more</a>
V1528	Right Rear Marked By Contact	8	Not applicable (no airbag / not deployed)	<a href="#">more</a>

V1529	Driver Module Type	1	H-pattern flaps	<a href="#">more</a>
V1530	Right Front Module Type	1	H-pattern flaps	<a href="#">more</a>
V1531	Left Rear Module Type	0	No airbag present	<a href="#">more</a>
V1532	Right Rear Module Type	0	No airbag present	<a href="#">more</a>
V1533	Driver Module Cover Dam.	1	Flaps not damaged / marked	<a href="#">more</a>
V1534	Right Front Module Cover Dam.	1	Flaps not damaged / marked	<a href="#">more</a>
V1535	Left Rear Module Cover Dam.	0	No airbag	<a href="#">more</a>
V1536	Right Rear Module Cover Dam.	0	No airbag	<a href="#">more</a>
V1537	Driver Airbag Type	1	Original equipment	<a href="#">more</a>
V1538	Right Front Airbag Type	1	Original equipment	<a href="#">more</a>
V1539	Left Rear Airbag Type	0	No airbag	<a href="#">more</a>
V1540	Right Rear Airbag Type	0	No airbag	<a href="#">more</a>
V1541	Driver Airbag Vents	2	Vents present	<a href="#">more</a>
V1542	Right Front Airbag Vents	2	Vents present	<a href="#">more</a>
V1543	Left Rear Airbag Vents	0	No airbag	<a href="#">more</a>
V1544	Right Rear Airbag Vents	0	No airbag	<a href="#">more</a>
V1545	Driver Knee Bolster Equipped	0	No	<a href="#">more</a>
V1546	Right Front Knee Bolster Equipped	0	No	<a href="#">more</a>
V1547	Left Rear Knee Bolster Equipped	0	No	<a href="#">more</a>
V1548	Right Rear Knee Bolster Equipped	0	No	<a href="#">more</a>
V1549	Driver Knee Bolster Deploy	8	Not applicable (no airbag)	<a href="#">more</a>
V1550	Right Front Knee Bolster Deploy	8	Not applicable (no airbag)	<a href="#">more</a>
V1551	Left Rear Knee Bolster Deploy	8	Not applicable (no airbag)	<a href="#">more</a>
V1552	Right Rear Knee Bolster Deploy	8	Not applicable (no airbag)	<a href="#">more</a>
V1553	Left Front Number of Tethers	2	Tethers	<a href="#">more</a>
V1554	Left Front Number of Vents	2	Vents	<a href="#">more</a>
V1555	Right Front Number of Tethers	8	Not applicable (no airbag)	<a href="#">more</a>
V1556	Right Front Number of Vents	2	Vents	<a href="#">more</a>
V1557	Left Rear Number of Tethers	8	Not applicable (no airbag)	<a href="#">more</a>
V1558	Left Rear Number of Vents	8	Not applicable (no airbag)	<a href="#">more</a>

V1559	Right Rear Number of Tethers	8	Not applicable (no airbag)	<a href="#">more</a>
V1560	Right Rear Number of Vents	8	Not applicable (no airbag)	<a href="#">more</a>

## Case Vehicle Interior

[Back to Top](#)

Variable Number	Variable Name	Code Value	Code Description	Other Options
V1601	Left Front Door Damaged	0	No	<a href="#">more</a>
V1602	Right Front Door Damaged	0	No	<a href="#">more</a>
V1603	Left Front Hardware Damaged	0	No	<a href="#">more</a>
V1604	Right Front Hardware Damaged	0	No	<a href="#">more</a>
V1605	Left Front Armrest Damaged	0	No	<a href="#">more</a>
V1606	Right Front Armrest Damaged	0	No	<a href="#">more</a>
V1607	Left Front Glass Damaged	0	No	<a href="#">more</a>
V1608	Right Front Glass Damaged	0	No	<a href="#">more</a>
V1609	Left Rear Door Area Damaged	0	No	<a href="#">more</a>
V1610	Right Rear Door Area Damaged	0	No	<a href="#">more</a>
V1611	Left Rear Hardware Damaged	0	No	<a href="#">more</a>
V1612	Right Rear Hardware Damaged	0	No	<a href="#">more</a>
V1613	Left Rear Armrest Damaged	0	No	<a href="#">more</a>
V1614	Right Rear Armrest Damaged	0	No	<a href="#">more</a>
V1615	Left Rear Glass Damaged	0	No	<a href="#">more</a>
V1616	Right Rear Glass Damaged	0	No	<a href="#">more</a>
V1617	Left Roof Side Rail Damaged	0	No	<a href="#">more</a>
V1618	Right Roof Side Rail Damaged	0	No	<a href="#">more</a>
V1619	Left B-pillar Damaged	0	No	<a href="#">more</a>
V1620	Right B-pillar Damaged	0	No	<a href="#">more</a>
V1621	Left C-pillar Damaged	0	No	<a href="#">more</a>
V1622	Right C-pillar Damaged	0	No	<a href="#">more</a>
V1623	Left D-pillar Damaged	8	Not applicable	<a href="#">more</a>
V1624	Right D-pillar Damaged	8	Not applicable	<a href="#">more</a>

V1625	Left Headlining Damaged	0	No	<a href="#">more</a>
V1626	Right Headlining Damaged	0	No	<a href="#">more</a>
V1627	Left Roof Structure Damaged	0	No	<a href="#">more</a>
V1628	Right Roof Structure Damaged	0	No	<a href="#">more</a>
V1629	Left T/sun Roof Damaged	8	Not applicable	<a href="#">more</a>
V1630	Right T/sun Roof Damaged	8	Not applicable	<a href="#">more</a>
V1631	Other Left Side Item Damagd	8	Not applicable	<a href="#">more</a>
V1632	Other Right Side Item Damagd	8	Not applicable	<a href="#">more</a>
V1633	Foot Controls Damaged	4	Yes, occupant contact	<a href="#">more</a>
V1634	Ignition Key Damaged	0	No	<a href="#">more</a>
V1635	Rear View Mirror Damaged	1	Yes	<a href="#">more</a>
V1636	Sunvisor/fitting Damaged	0	No	<a href="#">more</a>
V1637	Windshld Molding Damaged	0	No	<a href="#">more</a>
V1638	Left A-pillar Damaged	0	No	<a href="#">more</a>
V1639	Right A-pillar Damaged	0	No	<a href="#">more</a>
V1640	Console Damaged	0	No	<a href="#">more</a>
V1641	Transmissn Lever Damaged	0	No	<a href="#">more</a>
V1642	Horn/spoke Shroud Damagd	0	No	<a href="#">more</a>
V1643	Upper Panel Damaged	0	No	<a href="#">more</a>
V1644	Mid Panel Damaged	4	Yes, occupant contact	<a href="#">more</a>
V1645	Lower Panel Damaged	4	Yes, occupant contact	<a href="#">more</a>
V1646	Ashtray Damaged	0	No	<a href="#">more</a>
V1647	Control Knob/lever Damaged	0	No	<a href="#">more</a>
V1648	Glove Compart Area Damaged	1	Yes	<a href="#">more</a>
V1649	Instruments Damaged	0	No	<a href="#">more</a>
V1650	Park Brake Release Damaged	0	No	<a href="#">more</a>
V1651	Park Brake Pedal Damaged	0	No	<a href="#">more</a>
V1652	A/c Or Upper Vent Damagd	0	No	<a href="#">more</a>
V1653	Heater Or A/c Duct Damaged	0	No	<a href="#">more</a>
V1654	Radio Damaged	0	No	<a href="#">more</a>
V1655	Other Front Item Damaged	8	Not applicable	<a href="#">more</a>
V1656	Rear Backlight Damaged	0	No	<a href="#">more</a>
V1657	Backlight Header Damaged	0	No	<a href="#">more</a>
V1658	Vertical Console Damaged	0	No	<a href="#">more</a>
V1659	Roof Console Damaged	8	Not applicable	<a href="#">more</a>



## Case Vehicle Seats

[Back to Top](#)

Variable Number	Variable Name	Code Value	Code Description	Other Options
V1701	Driver Front Seat Type	05	Bucket	<a href="#">more</a>
V1702	Passenger Front Seat Type	05	Bucket	<a href="#">more</a>
V1703	Driver Seat Mount Type	1	Standard	<a href="#">more</a>
V1704	Passenger Seat Mount Type	1	Standard	<a href="#">more</a>
V1705	Driver Swivel Mech Equipped	0	No	<a href="#">more</a>
V1706	Passenger Swivel Mech Equipped	0	No	<a href="#">more</a>
V1707	Driver Seat Original Equipment	1	Yes	<a href="#">more</a>
V1708	Passenger Seat Original Equipment	1	Yes	<a href="#">more</a>
V1709	Driver Seat/rear Oc Contct	8	Not applicable	<a href="#">more</a>
V1710	Passenger Seat/rear Oc Contct	8	Not applicable	<a href="#">more</a>
V1711	Driver Seat Damage	0	None	<a href="#">more</a>
V1712	Passenger Seat Damage	0	None	<a href="#">more</a>
V1713	Cntr Frnt Armrest Damagd	8	Not applicable	<a href="#">more</a>
V1714	Driver Seat-back Rotation	0	None apparent	<a href="#">more</a>
V1715	Passenger Seat-back Rotation	0	None apparent	<a href="#">more</a>
V1716	Driver Seat-back Type	3	Reclining	<a href="#">more</a>
V1717	Passenger Seat-back Type	3	Reclining	<a href="#">more</a>
V1718	Driver Seat-back Lock Type	1	Manual	<a href="#">more</a>
V1719	Passenger Seat-back Lock Type	1	Manual	<a href="#">more</a>
V1720	Driver Seat-back Lock Held	1	Yes	<a href="#">more</a>
V1721	Passenger Seat-back Lock Held	1	Yes	<a href="#">more</a>
V1722	Driver Recliner Mech Held	1	Yes	<a href="#">more</a>
V1723	Passenger Recliner Mech Held.	1	Yes	<a href="#">more</a>
V1724	Driver Head Restraint Type	1	Adjustable	<a href="#">more</a>
V1725	Passenger Head Restraint Type	1	Adjustable	<a href="#">more</a>
V1726	Driver Head Rest Removed	0	No	<a href="#">more</a>
	Passenger Head Rest			

V1727	Removed	0	No	<a href="#">more</a>
V1728	Driver Head Rest Adjustmnt	2	Down	<a href="#">more</a>
V1729	Passenger Head Rest Adjustmnt	1	Up	<a href="#">more</a>
V1730	Driver Head Rest Damage	0	None	<a href="#">more</a>
V1731	Passenger Head Rest Damage	0	None	<a href="#">more</a>
V1732	Driver Rear Impact Counter	0	None	<a href="#">more</a>
V1733	Passenger Rear Impact Counter	0	None	<a href="#">more</a>
V1734	Driver Seat Adjustmnt Type	1	Manual	<a href="#">more</a>
V1735	Passenger Seat Adjustmnt Type	1	Manual	<a href="#">more</a>
V1736	Driver Seat Adjust Provisn	1	2-way	<a href="#">more</a>
V1737	Passenger Seat Adjust Provisn	1	2-way	<a href="#">more</a>
V1738	Driver Seat Adjuster Dam	0	None	<a href="#">more</a>
V1739	Passenger Seat Adjuster Dam	0	None	<a href="#">more</a>
V1740	Driver Seat Adjuster Sep	8	Not applicable	<a href="#">more</a>
V1741	Passenger Seat Adjuster Sep	8	Not applicable	<a href="#">more</a>
V1742	Driver Seat Pre-crash Pos	3	Rearward	<a href="#">more</a>
V1743	Passenger Seat Pre-crash Pos	3	Rearward	<a href="#">more</a>
V1744	Left Rear Seat Type	2	Folding	<a href="#">more</a>
V1745	Rght Rear Seat Type	2	Folding	<a href="#">more</a>
V1746	Left Rear Seat Damage	0	None	<a href="#">more</a>
V1747	Rght Rear Seat Damage	0	None	<a href="#">more</a>
V1748	Cntr Rear Armrest Damagd	8	Not applicable	<a href="#">more</a>
V1749	Left Rear Seat-back Left Lock Equipped	1	Yes	<a href="#">more</a>
V1750	Right Rear Seat-back Left Lock Equipped	8	Not applicable	<a href="#">more</a>
V1751	Left Rear Seat-back Left Lock Held	1	Yes	<a href="#">more</a>
V1752	Right Rear Seat-back Left Lock Held	8	Not applicable	<a href="#">more</a>
V1753	Left Rear Seat-back Right Lock Equipped	8	Not applicable	<a href="#">more</a>
V1754	Right Rear Seat-back Right Lock Equipped	1	Yes	<a href="#">more</a>
V1755	Left Rear Seat-back Right Lock Held	8	Not applicable	<a href="#">more</a>
	Right Rear Seat-back Right			

V1756	Lock Held	1	Yes	<a href="#">more</a>
V1757	Left 3rd Seat Equipped	0	No	<a href="#">more</a>
V1758	Right 3rd Seat Equipped	0	No	<a href="#">more</a>
V1759	Left 3rd Row Type Seat	0	None	<a href="#">more</a>
V1760	Right 3rd Row Type Seat	0	None	<a href="#">more</a>
V1761	Left 3rd Seat Damage	8	Not applicable	<a href="#">more</a>
V1762	Right 3rd Seat Damage	8	Not applicable	<a href="#">more</a>
V1763	Left 3rd Seat Cushion Dam	8	Not applicable	<a href="#">more</a>
V1764	Right 3rd Seat Cushion Dam	8	Not applicable	<a href="#">more</a>
V1765	Left 3rd Seat L/c Lock Equipped	8	Not applicable	<a href="#">more</a>
V1766	Right 3rd Seat L/c Lock Equipped	8	Not applicable	<a href="#">more</a>
V1767	Left 3rd Seat L/c Lock Held	8	Not applicable	<a href="#">more</a>
V1768	Right 3rd Seat L/c Lock Held	8	Not applicable	<a href="#">more</a>
V1769	Left 3rd Seat Right Lock Equipped	8	Not applicable	<a href="#">more</a>
V1770	Right 3rd Seat Right Lock Equipped	8	Not applicable	<a href="#">more</a>
V1771	Left 3rd Seat Right Lock Held	8	Not applicable	<a href="#">more</a>
V1772	Right 3rd Seat Right Lock Held	8	Not applicable	<a href="#">more</a>
V1773	Rear Head Restraints	1	Equipped	<a href="#">more</a>

### Case Vehicle Side Airbag(s)

[Back to Top](#)

Variable Number	Variable Name	Code Value	Code Description	Other Options
V1801	Side Airbag Equipped	0	Not equipped	<a href="#">more</a>
V1802	Left Front Seatback Mount Deploy	0	Not equipped	<a href="#">more</a>
V1803	Right Front Seatback Mount Deploy	0	Not equipped	<a href="#">more</a>
V1804	Left Rear Seatback Mount Deploy	0	Not equipped	<a href="#">more</a>
V1805	Right Rear Seatback Mount Deploy	0	Not equipped	<a href="#">more</a>
V1806	Left Front Seatback Module Type	0	Not equipped	<a href="#">more</a>
	Right Front Seatback Module	0		

V1807	Type		Not equipped	<a href="#">more</a>
V1808	Left Rear Seatback Module Type	0	Not equipped	<a href="#">more</a>
V1809	Right Rear Seatback Module Type	0	Not equipped	<a href="#">more</a>
V1810	Left Front Seatback Airbag Type	0	Not equipped	<a href="#">more</a>
V1811	Right Front Seatback Airbag Type	0	Not equipped	<a href="#">more</a>
V1812	Left Rear Seatback Airbag Type	0	Not equipped	<a href="#">more</a>
V1813	Right Rear Seatback Airbag Type	0	Not equipped	<a href="#">more</a>
V1814	Left Front Seatback Airbag Cond.	0	Not equipped	<a href="#">more</a>
V1815	Right Front Seatback Airbag Cond.	0	Not equipped	<a href="#">more</a>
V1816	Left Rear Seatback Airbag Cond.	0	Not equipped	<a href="#">more</a>
V1817	Right Rear Seatback Airbag Cond.	0	Not equipped	<a href="#">more</a>
V1818	Left Front Door-mounted Deploy	0	Not equipped	<a href="#">more</a>
V1819	Right Front Door-mounted Deploy	0	Not equipped	<a href="#">more</a>
V1820	Left Rear Door-mounted Deploy	0	Not equipped	<a href="#">more</a>
V1821	Right Rear Door-mounted Deploy	0	Not equipped	<a href="#">more</a>
V1822	Left Front Door Module Type	0	Not equipped	<a href="#">more</a>
V1823	Right Front Door Module Type	0	Not equipped	<a href="#">more</a>
V1824	Left Rear Door Module Type	0	Not equipped	<a href="#">more</a>
V1825	Right Rear Door Module Type	0	Not equipped	<a href="#">more</a>
V1826	Left Front Door Airbag Type	0	Not equipped	<a href="#">more</a>
V1827	Right Front Door Airbag Type	0	Not equipped	<a href="#">more</a>
V1828	Left Rear Door Airbag Type	0	Not equipped	<a href="#">more</a>
V1829	Right Rear Door Airbag Type	0	Not equipped	<a href="#">more</a>
	Left Front Door Airbag			

V1830	Condition	0	Not equipped	<a href="#">more</a>
V1831	Right Front Door Airbag Condition	0	Not equipped	<a href="#">more</a>
V1832	Left Rear Door Airbag Condition	0	Not equipped	<a href="#">more</a>
V1833	Right Rear Door Airbag Condition	0	Not equipped	<a href="#">more</a>
V1834	Left Front Roof Mounted Deploy	0	Not equipped	<a href="#">more</a>
V1835	Right Front Roof Mounted Deploy	0	Not equipped	<a href="#">more</a>
V1836	Left Rear Roof Mounted Deploy	0	Not equipped	<a href="#">more</a>
V1837	Right Rear Roof Mounted Deploy	0	Not equipped	<a href="#">more</a>
V1838	Left Front Roof Module Type	0	Not equipped	<a href="#">more</a>
V1839	Right Front Roof Module Type	0	Not equipped	<a href="#">more</a>
V1840	Left Rear Roof Module Type	0	Not equipped	<a href="#">more</a>
V1841	Right Rear Roof Module Type	0	Not equipped	<a href="#">more</a>
V1842	Left Front Roof Airbag Type	0	Not equipped	<a href="#">more</a>
V1843	Right Front Roof Airbag Type	0	Not equipped	<a href="#">more</a>
V1844	Left Rear Roof Airbag Type	0	Not equipped	<a href="#">more</a>
V1845	Right Rear Roof Airbag Type	0	Not equipped	<a href="#">more</a>
V1846	Left Front Roof Airbag Condition	0	Not equipped	<a href="#">more</a>
V1847	Right Front Roof Airbag Condition	0	Not equipped	<a href="#">more</a>
V1848	Left Rear Roof Airbag Condition	0	Not equipped	<a href="#">more</a>
V1849	Right Rear Roof Airbag Condition	0	Not equipped	<a href="#">more</a>

## EDR -- Event Data Recorder

[Back to Top](#)

Variable Number	Variable Name	Code Value	Code Description	Other Options
V1901	Case Vehicle EDR Equipped	0	Not equipped	<a href="#">more</a>
V1902	Type Of File Recovered	0	Not equipped	<a href="#">more</a>
V1903	EDR Pre-crash Braking	0	Not equipped	<a href="#">more</a>

V1904	Event Data Recorder (EDR) Pre-impact Speed	91	Not equipped	<a href="#">more</a>
V1905	EDR Driver Belt Status	0	Not equipped	<a href="#">more</a>
V1906	EDR Right Front Belt Status	0	Not equipped	<a href="#">more</a>
V1907	Right Front Airbag Suppressed	0	Not equipped	<a href="#">more</a>
V1908	Sir Warning Lamp Status	0	Not equipped	<a href="#">more</a>
V1909	Time Between Near Deployment and Deployment (in Seconds)	0	Not equipped	<a href="#">more</a>
V1910	Time Between Algorithm Enable and Deployment (in ms)	000	Not equipped	<a href="#">more</a>
V1911	Maximum Recorded Longitudinal Velocity Change (mph)	000	No time / not collected	<a href="#">more</a>
V1912	Maximum Recorded Lateral Velocity Change (mph)	000	No time / not collected	<a href="#">more</a>
V1913	More Than One Deploy?	0	Not equipped	<a href="#">more</a>

Driver Airbag

AIRBAG NUMBER ON DRIVER SIDE:

**NISSAN HF**  
**985 70-8B700**  
**0005885**  
**23 12 98**

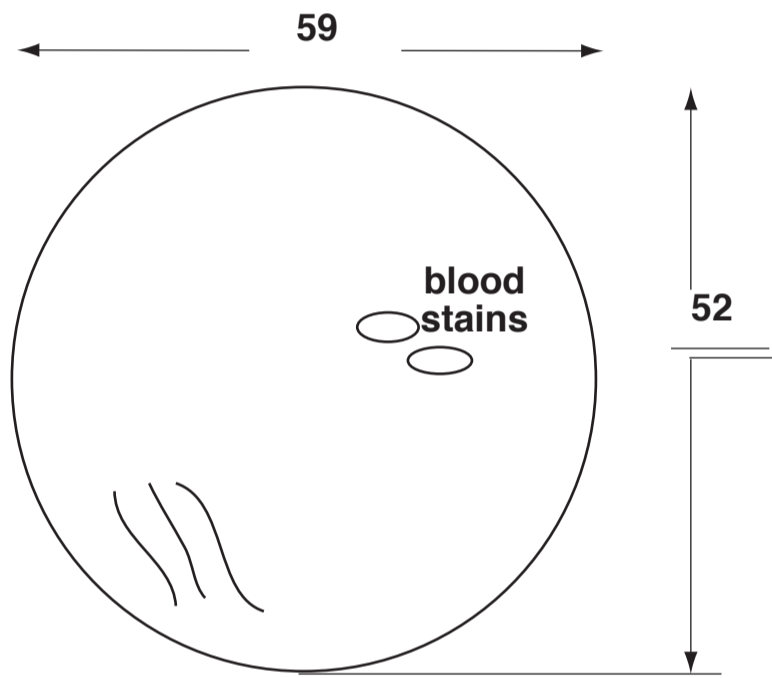

**brown marks**

Vents:  Y N **2**  
if yes, how many: \_\_\_\_\_

Tethers:  Y N **2**  
if yes, how many: \_\_\_\_\_

Driver Airbag Doors

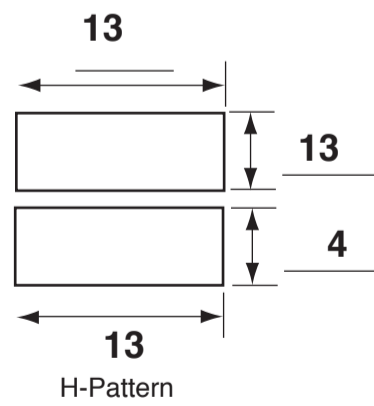

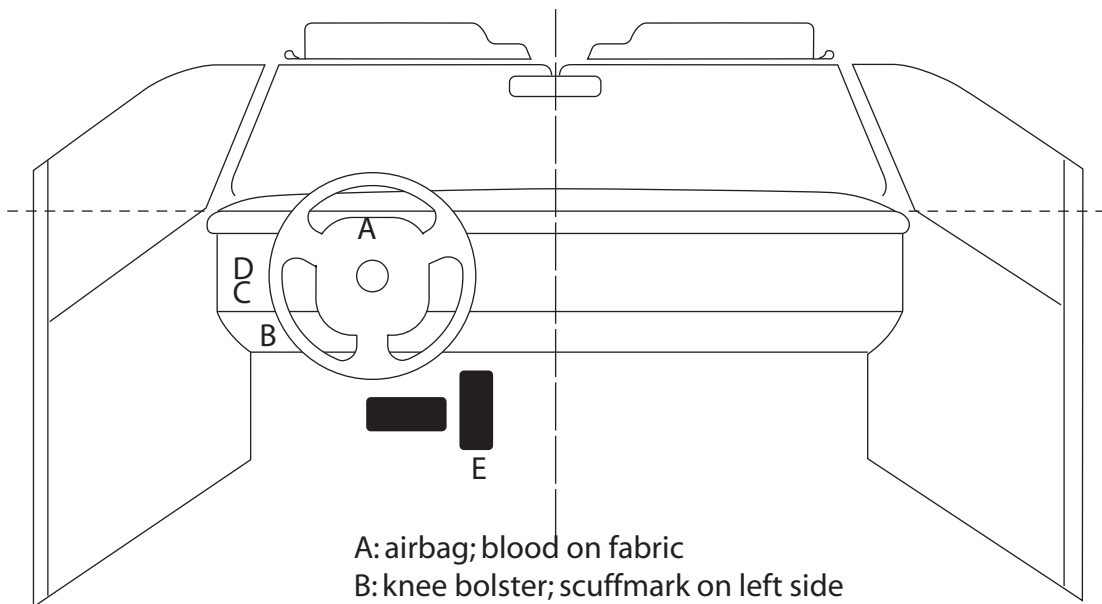
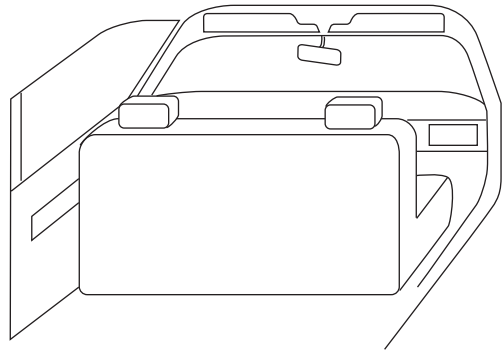
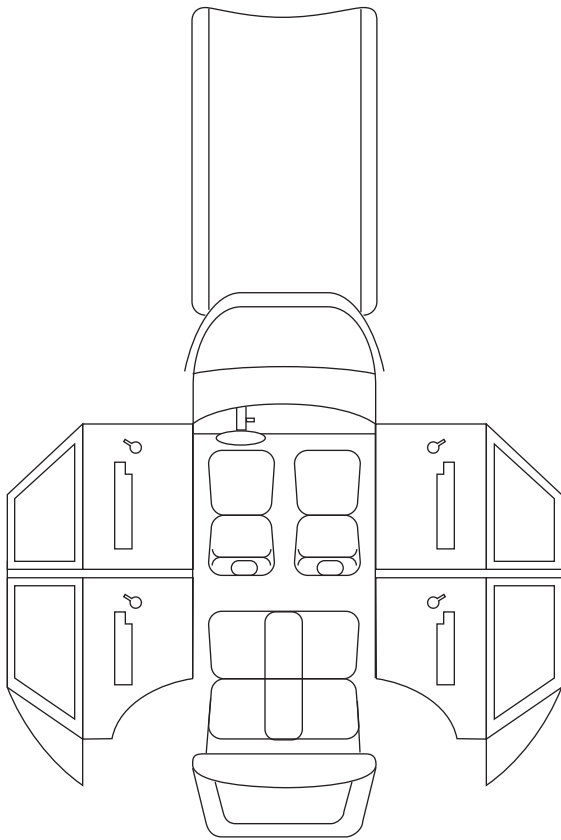

- A: airbag; blood on fabric
- B: knee bolster; scuffmark on left side
- C: fuse box cover; broke off
- D: light control knob on mid-IP; displaced
- E: gas pedal; bent to left



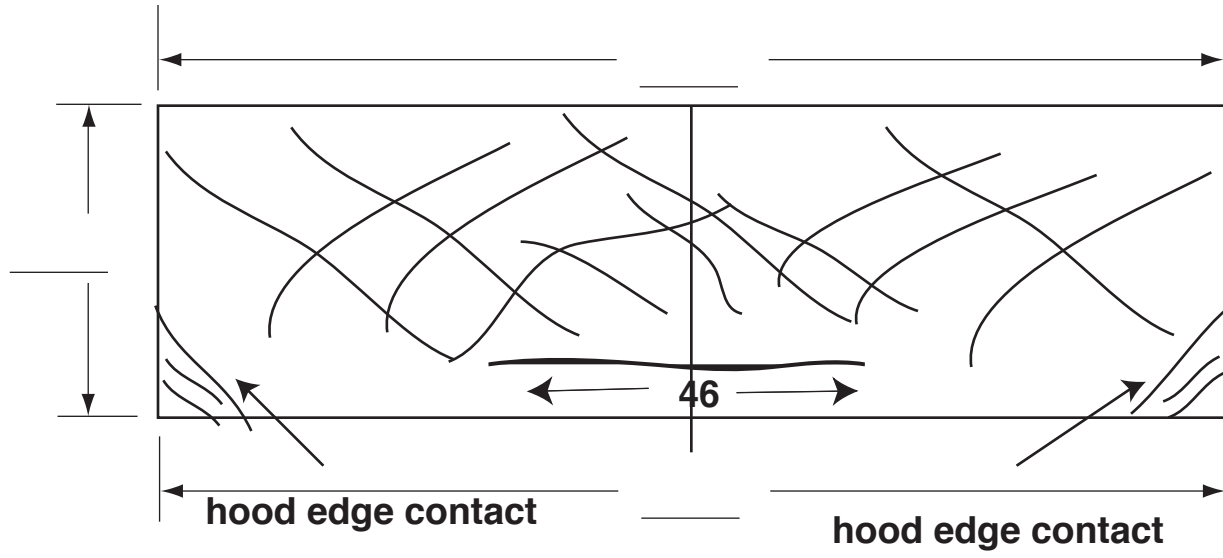

WINDSHIELD MARK ON CASE VEHICLE:

**NISSAN  
LAMINATED**

**M57**

<b>LN</b>
-----------

**A S 1**

**EVSS**

**DOT177**

**MEXICO**

MEASUREMENTS IN CENTIMETERS

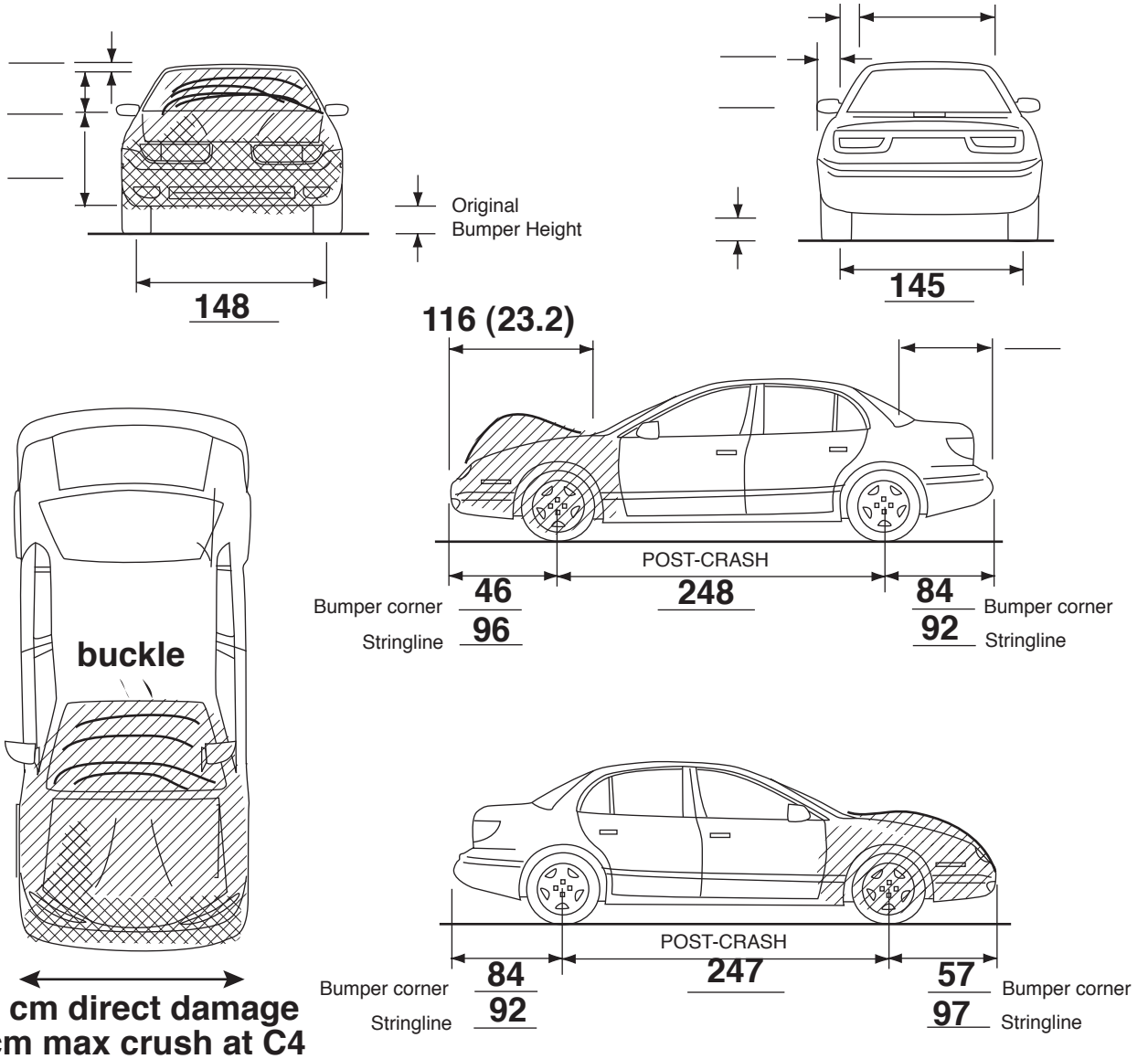

Passenger airbag number: **NISSAN**  
**98575-8B700**  
**5908**  
**23 02 98**

**Passenger Airbag**

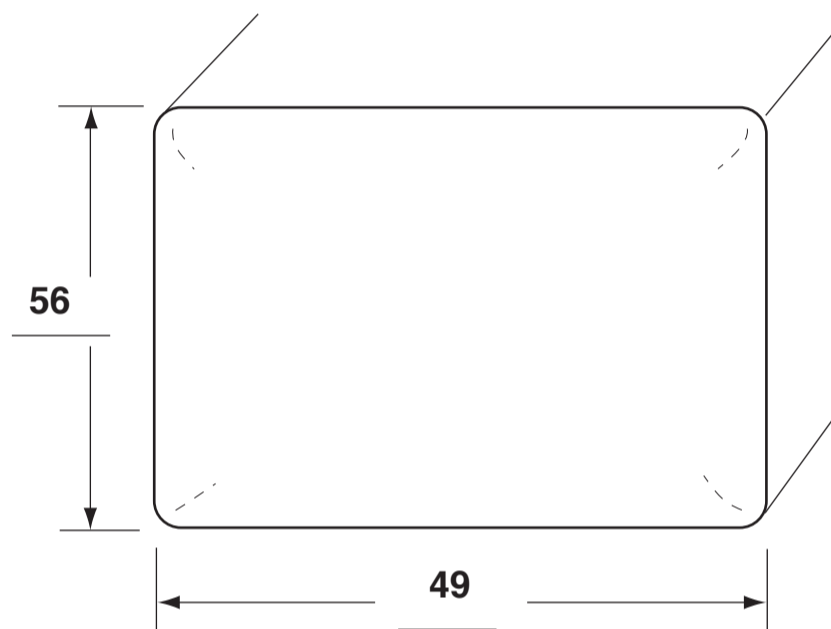

Vents:  Y  N  
if yes, how many: 2

Tethers: Y  N  
if yes, how many: \_\_\_\_\_

**Passenger Airbag Doors**

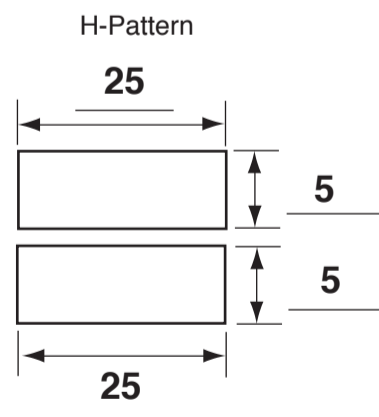

































WARNING: NEVER DRINK AND DRIVE. NEVER DRINK AND DRIVE. NEVER DRINK AND DRIVE.











CRUISE CONT



R

4

E

MPH

100

120

OFF

2ND

3RD

PS7





















































































