

## Case 492 : Narrative

Case vehicle (A): 2002 Mercury	Vehicle (B): 1995 Plymouth
Type: Cougar, 2-door hatchback	Type: Grand Voyager SE, minivan
Driver: 19-year-old female	Driver: 44-year-old male
CDC: 12-FYEW-1	CDC: 99-0000-0

### SITUATION

[1](#) It was daylight, the sky was clear, and the asphalt surface of the T-type intersection of the north-south and east-west two-lane roads was dry and free of defects. The posted speed limit on the north-south road was 45 mph (72 kph) and [2](#) case vehicle (A) was traveling north at an unknown speed in the northbound lane, approaching the intersection. [3](#) Vehicle (B) was stopped in the northbound lane while the driver was waiting to turn left to travel west on the east-west road. The driver of case vehicle (A) did not notice that vehicle (B) was stopped until it was too late to avoid a collision, and the front of case vehicle (A) struck the rear end of vehicle (B). Both vehicles were towed from the scene due to damage.

The police accident report (PAR) indicates B-level injuries for the driver of case vehicle (A) and no injuries for the driver of vehicle (B). Neither driver received any medical treatment.

### GENERAL VEHICLE DAMAGE AND ESTIMATED CRASH SEVERITIES

[4](#) Damage to the front of case vehicle (A) was moderate. [5](#) Direct damage began at the left-front bumper corner and extended 94-cm to the right, resulting in 62-percent vehicle overlap (% VOL). [6](#) The maximum rearward crush was 19 cm and it occurred at the left-front bumper corner.

Vehicle (B) was not available for inspection.

Using the missing-vehicle algorithm of the WinSMASH crash-reconstruction program and a crush profile [7](#) [8](#) [9](#) for case vehicle (A), the following impact severities were estimated:

		Estimated Velocity Change - kph (mph)		
Vehicle	Variable	Total	Longitudinal	Latitudinal
Case Vehicle (A)	delta V	18 (11)	-18 (-11)	0 (0)
Vehicle (B)	delta V	15 (9)	15 (9)	0 (0)

### DESCRIPTION OF DAMAGE TO CASE VEHICLE (A)

#### Exterior

[10](#) In the front, the left side of the bumper, the engine compartment, and the hood were crushed rearward, and [11](#) the front section of the hood was buckled down. [12](#) The rear edge of the hood was

elevated and it had contacted and cracked the lower-left section of the windshield. [13](#) [14](#) The right side of the windshield was also cracked in two places from contact by the deploying dash-mounted airbag.

On the left side, [15](#) the fender and front wheel were crushed rearward, [16](#) reducing the left-side wheelbase by 4 cm. [17](#) There was no other left-side damage and [18](#) there was no damage to the rear of case vehicle (A).

[19](#) [20](#) On the right side, the fender was deflected to the left but there was no other right-side damage and there was no change in the right-side wheelbase.

## Interior

[21](#) This vehicle was equipped with steering-wheel and dash-mounted frontal-impact airbags and both deployed during the frontal impact with vehicle (B). [22](#) [23](#) This vehicle was also equipped with front-row seatback-mounted side-impact airbags that did not deploy in the frontal impact. In the driver seating area, [24](#) there was a deposit of blood and/or make-up on the deployed steering-wheel airbag but there was no damage to the airbag. [25](#) [26](#) There was some debris on the tilt steering-wheel adjustment lever and [27](#) there were scuffmarks on the knee bolster below and to the left of the steering column. [28](#) The toe pan was buckled and displaced rearward about 5 cm. [29](#) [30](#) [31](#) [32](#) [33](#) [34](#) [35](#) There was no other damage in the driver area.

In the center-front area, [36](#) the trim around the transmission lever was separated [37](#) but there was no other damage. In the right-front seating area, [38](#) the dash-mounted airbag cover was bowed from contact with the windshield [39](#) [40](#) but there was no other damage.

[41](#) [42](#) [43](#) There was no other interior damage.

## OCCUPANT KINEMATICS AND INJURIES

[44](#) The 157-cm, 45-kg (5-ft 2-in, 99-lb), 19-year-old female driver was using the three-point-belt and [45](#) the steering-wheel airbag deployed in the frontal impact, but the side-impact airbag did not deploy. [46](#) There were no loading marks on the plastic D-ring but [47](#) belt use is indicated by loading marks on the continuous loop of the sliding latch plate.

During the frontal impact, the driver moved forward relative to the vehicle interior, into the airbag, the seatbelt, and the knee bolster. She sustained a laceration to the middle of the upper lip, probably from contact by the deploying steering-wheel airbag. She sustained a contusion across the chest from loading by the shoulder belt, and she sustained a contusion and a laceration to the right knee from contact with the knee bolster.

The following table and [48](#) drawing summarize the injuries sustained by the driver of case vehicle (A).

Occupant: Driver	Age: 19 years	Gender: Female		
Restraints: 3-point belt; steering-wheel airbag	Stature: 157 cm (5 ft, 2 in)	Mass: 45 kg (99 lb)		
Injury Description	A.I.S.	Injury Source		
		Definite	Probable	Possible
—	—			

Laceration, mid upper lip	1	—	Airbag	—
Contusion, across chest	1	Shoulder belt	—	—
Contusion and laceration, right knee	1	Knee bolster	—	—
Maximum A.I.S. Level	1	—	—	—
Injury Severity Score	1	—	—	—

CASE NO.: 492

CASE VEHICLE: 2002 Mercury

TYPE: Cougar, 2-door hatchback

OCCUPANT: Driver: 19-year-old female

STATURE: 157 cm (5 ft, 2 in) MASS: 45 kg (99 lb)

RESTRAINTS: 3-point belt; steering-wheel airbag

SEVERITY: MAIS - 1 : ISS - 1

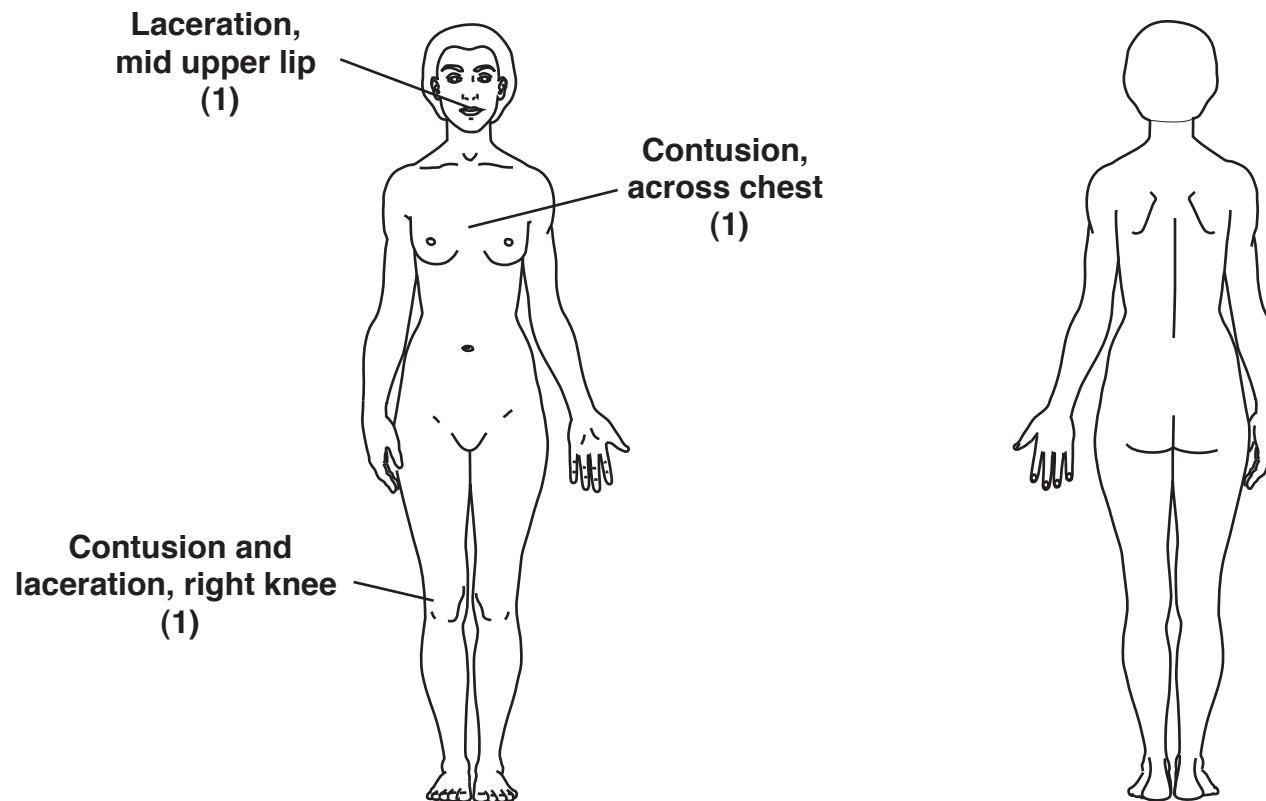

Case No.: **492**

Case Veh. (A): **2002 Mercury**

Type: **Cougar, 2-door hatchback**

Driver: **19-year-old female**

Veh. (B): **1995 Plymouth Grand Voyager SE, minivan**

Light Conditions: **Daylight**

Weather: **Clear**

Road Surface: **Dry**

Road Construction: **Asphalt**

NORTH →

Speed Limit 45 mph (72 kph)

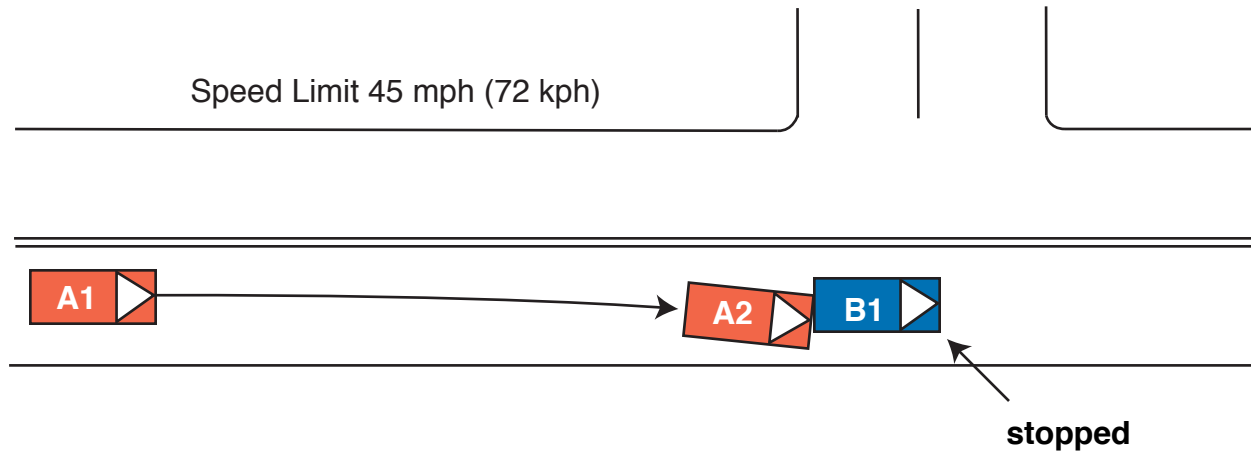

# 492: Vehicle Report

Click on Section Name to jump directly to that Section —

- [General Information](#)
  - [Other Vehicle](#)
  - [Case Vehicle General](#)
  - [Case Vehicle Damage Description](#)
  - [Crash Reconstruction](#)
  - [Case Vehicle Tires & Rims](#)
  - [Case Vehicle Fuel Tank](#)
  - [Case Vehicle Fuel Leakage](#)
  - [Case Vehicle Fire](#)
  - [Case Vehicle Exterior](#)
  - [Case Vehicle Steering Column/Rim](#)
  - [Case Vehicle Intrusion](#)
  - [Case Vehicle Airbag\(s\)](#)
  - [Case Vehicle Interior](#)
  - [Case Vehicle Seats](#)
  - [Case Vehicle Side Airbag\(s\)](#)
  - [EDR -- Event Data Recorder](#)
- 

## General Information

[Back to Top](#)

Variable Number	Variable Name	Code Value	Code Description	Other Options
V0204	Collision Hour	1126	Time of day (24 hour clock)	<a href="#">more</a>
V0205	State Fips Code	26	Michigan	<a href="#">more</a>
V0206	Urban/rural Area	1	Urban	<a href="#">more</a>
V0207	Limited Access Highway	0	No	<a href="#">more</a>
V0208	Road Total Lanes	2	2 lanes	<a href="#">more</a>
V0209	Intersect Road Total Lanes	2	2 lanes	<a href="#">more</a>
V0210	Trafficway Flow	0	Not physically divided - two way traffic	<a href="#">more</a>
V0211	Road Surface Type	1	Asphalt	<a href="#">more</a>
V0212	Road Defects	0	No	<a href="#">more</a>
V0213	Construction Zone	0	No	<a href="#">more</a>
V0214	Road Alignment Vertical Plane	2	Crest of hill	<a href="#">more</a>

V0215	Road Alignment Horizontal Plane	1	Straight	<a href="#">more</a>
V0216	Surface Covering	10	Dry	<a href="#">more</a>
V0217	Visibility Limitation	0	None	<a href="#">more</a>
V0218	Visibility Obstruction	0	None	<a href="#">more</a>
V0219	Speed Limit	4	71-79 km/h .. 45 mph	<a href="#">more</a>
V0220	Precipitation Type	0	None	<a href="#">more</a>
V0221	Precipitation Rate	8	Not applicable	<a href="#">more</a>
V0222	Temperature	6	16 to 25 C .. 60 to 77 F	<a href="#">more</a>
V0223	Crosswind	9	Unknown	<a href="#">more</a>
V0224	Light Conditions	1	Daylight	<a href="#">more</a>
V0225	Mechanical Malfunction Mention	0	No	<a href="#">more</a>
V0226	Case Vehicle And Object	0	No	<a href="#">more</a>
V0227	Case Vehicle Rollover	0	No	<a href="#">more</a>
V0228	Rollover Location	0	No rollover	<a href="#">more</a>
V0229	Roll Direction	0	No rollover	<a href="#">more</a>
V0230	Rollover Initiation Type	0	No rollover	<a href="#">more</a>
V0231	Rollover Number Of Turns	0	No rollover	<a href="#">more</a>
V0232	Case Vehicle Preimpact Braking	0	No	<a href="#">more</a>
V0233	Case Vehicle Preimpact Stability	1	Case vehicle tracking before impact	<a href="#">more</a>
V0234	Case Vehicle Ran Off Roadway	0	No	<a href="#">more</a>
V0235	Moving Case Vehicle Contacted Moving Vehicle	0	No	<a href="#">more</a>
V0236	Case Vehicle Contacted Stopped Vehicle	1	Yes	<a href="#">more</a>
V0237	Stopped Case Vehicle Contacted Vehicle	0	No	<a href="#">more</a>
V0238	Total Vehicles Hit By Case Vehicle	1	1 vehicle	<a href="#">more</a>
V0239	Any Fire In Crash?	0	No	<a href="#">more</a>
V0240	Maximum Police Severity-acc	2	B - Non-Incapacitating Injury	<a href="#">more</a>
V0241	Driver Alcohol Involvmnt	0	Had not been drinking	<a href="#">more</a>
V0242	Driver Alcohol BAC (Case Vehicle)	80	No test	<a href="#">more</a>
V0243	Driver Impairment Mention	0	No	<a href="#">more</a>
V0244	Driver Distraction	01	Attentive or not distracted	<a href="#">more</a>

V0245	Driver Drug Involvement	0	None	<a href="#">more</a>
V0246	Driver Drug Type	0	No drug use	<a href="#">more</a>
V0247	Driven/towed From Scene	2	Towed Due to Damage	<a href="#">more</a>

## Other Vehicle

[Back to Top](#)

Variable Number	Variable Name	Code Value	Code Description	Other Options
V0301	Other Vehicle VIN	1P4GH4434SXXXXXXX	<a href="#">Click for Contacted Vehicle figure</a>	<a href="#">more</a>
V0302	Other Vehicle Manufacturer/Body Code	13411	—	—
V0303	Other Vehicle Manufacturer	134	Plymouth	<a href="#">more</a>
V0304	Other Vehicle Body Code	11	Passenger van; panel or cargo van	<a href="#">more</a>
V0305	Other Vehicle Make/model	3320	Voyager (II) Minivan	<a href="#">more</a>
V0306	Other Vehicle Model Year	1995	Year	<a href="#">more</a>
V0307	Other Vehicle Mass	001621 kg	Mass (Kg.)	<a href="#">more</a>
V0308	Other Vehicle Number	0	No separate report	<a href="#">more</a>
V0309	Other Vehicle Number of Occupants	01	number of occupants	<a href="#">more</a>
V0310	Other Vehicle Traveling Speed	000 kph	Parked or just starting	<a href="#">more</a>
V0311	Highest Police Injury Severity	0	O - No Injury	<a href="#">more</a>
V0312	Other Vehicle Type	11	Small van (e.g. Econoline)	<a href="#">more</a>
V0313	Other Vehicle Wheelbase in Centimeters	303 cm	Actual Wheelbase (cm)	<a href="#">more</a>
V0314	Other Vehicle Average Track Width	155 cm	actual measurement (cm)	<a href="#">more</a>
V0315	Other Vehicle Overall Length	490 cm	actual measurement (cm)	<a href="#">more</a>
V0316	Other Vehicle Overall Width (OAW)	177 cm	actual measurement (cm)	<a href="#">more</a>
V0317	Other Vehicle Front Overhang	085 cm	actual measurement (cm)	<a href="#">more</a>
V0318	Other Vehicle Rear	101 cm	actual measurement (cm)	<a href="#">more</a>



	Overhang			
V0319	Other Vehicle Undeformed End Width (UEW)	150 cm	actual measurement (cm)	<a href="#">more</a>
V0320	Other Vehicle Engine Displacement	3.0 l	Liters	<a href="#">more</a>
V0321	Other Vehicle Engine: Number of Cylinders	06	number of cylinders	<a href="#">more</a>
V0322	Other Vehicle Direct Damage Length (DDL)	999	Unknown	<a href="#">more</a>
V0323	Other Vehicle Front-End Overlap	99	Missing or Not applicable	<a href="#">more</a>
V0324	Other Vehicle - Vehicle Overlap	99	Missing or Not applicable	<a href="#">more</a>

### Case Vehicle General

[Back to Top](#)

Variable Number	Variable Name	Code Value	Code Description	Other Options
V0401	VIN	1ZWHT61L32XXXXXXX	<a href="#">Click for Case Vehicle figure</a>	<a href="#">more</a>
V0402	Manufacturer/Body Code	12228	—	—
V0403	Vehicle Manufacturer	122	Lincoln-Mercury	<a href="#">more</a>
V0404	Vehicle Body Code	28	Intermediate 105-109.9 in. wb.	<a href="#">more</a>
V0405	Make/model Code	0922	Cougar	<a href="#">more</a>
V0406	Model Year	2002	Model year	<a href="#">more</a>
V0407	Vehicle Mass	001346 kg	Mass (Kg)	<a href="#">more</a>
V0408	Odometer Reading	888888	—	—
V0409	Number of Occupants	01	1 occupant	<a href="#">more</a>
V0410	Traveling Speed	999	Unknown	<a href="#">more</a>
V0411	Body Type	12	2-door sedan or coupe (any upper B-pillar)	<a href="#">more</a>
V0412	Stolen Vehicle	8	Not currently collected	<a href="#">more</a>
V0413	Body Structure	2	Unitized	<a href="#">more</a>
V0414	Transmission Type	1	Automatic	<a href="#">more</a>
V0415	Transmission Lever Location	2	Console	<a href="#">more</a>
V0416	Steering	1	Power	<a href="#">more</a>
V0417	Brakes	1	Power	<a href="#">more</a>
V0418	Brake Type	3	Disc - all wheels	<a href="#">more</a>
V0419	Adjustable Pedals?	0	No	<a href="#">more</a>

V0420	Brake Anti-lock Device	9	Unknown	<a href="#">more</a>
V0421	Air Conditioning in Vehicle	8	Not currently collected	<a href="#">more</a>
V0422	Drive Type	2	Front wheel	<a href="#">more</a>
V0423	Dual Rear Wheels	0	No	<a href="#">more</a>
V0424	Original Restraint System Type	3	Air bag	<a href="#">more</a>
V0425	Equipped With Roll Bar	0	No	<a href="#">more</a>
V0426	Roof Type	1	Solid	<a href="#">more</a>
V0427	Case Vehicle Wheelbase in Centimeters	270 cm	Actual Wheelbase	<a href="#">more</a>
V0428	Anti-lacerative Glass	8	Not Collected	<a href="#">more</a>
V0429	Case Vehicle average track Width	150 cm	actual measurement (cm)	<a href="#">more</a>
V0430	Case Vehicle Overall Length	470 cm	actual measurement (cm)	<a href="#">more</a>
V0431	Case Vehicle Overall Width (OAW)	177	actual measurement (cm)	<a href="#">more</a>
V0432	Case Vehicle Front Overhang	099 cm	actual measurement (cm)	<a href="#">more</a>
V0433	Case Vehicle Rear Overhang	103 cm	actual measurement (cm)	<a href="#">more</a>
V0434	Case Vehicle Undeformed End Width (UEW)	146 cm	actual measurement (cm)	<a href="#">more</a>
V0435	Case Vehicle Engine Displacement	2.5 l	Liters	<a href="#">more</a>
V0436	Case Vehicle Engine: Number of Cylinders	06	number of cylinders	<a href="#">more</a>
V0437	Case Vehicle Direct Damage Length (DDL)	094 cm	actual measurement (cm)	<a href="#">more</a>
V0438	Case Vehicle Front-end Overlap	64	percentage (%)	<a href="#">more</a>
V0439	Case Vehicle - Vehicle Overlap	62	percentage (%)	<a href="#">more</a>

### Case Vehicle Damage Description

[Back to Top](#)

Variable Number	Variable Name	Code Value	Code Description	Other Options

V0501	Maximum Sheet Metal Crush - Front	019 cm	Depth of Crush (cm)	<a href="#">more</a>
V0502	Maximum Sheet Metal Crush - Right Side	000 cm	No Crush (or less than 1 cm.)	<a href="#">more</a>
V0503	Maximum Sheet Metal Crush - Rear	000 cm	No Crush (or less than 1 cm.)	<a href="#">more</a>
V0504	Maximum Sheet Metal Crush - Left Side	000 cm	No Crush (or less than 1 cm.)	<a href="#">more</a>
V0505	Maximum Sheet Metal Crush - Roof	000 cm	No Crush (or less than 1 cm.)	<a href="#">more</a>
V0506	Maximum Sheet Metal Crush - Other	000 cm	No Crush (or less than 1 cm.)	<a href="#">more</a>
V0507	Seq In Chronological Ord	1	Yes	<a href="#">more</a>
V0508	Event 1 -impact Location	1	On Roadway	<a href="#">more</a>
V0509	Event 1 -Impact Configuration	14	FRONT of case veh - REAR of contacted veh	<a href="#">more</a>
V0510	Event 1 -Object/Vehicle Contactd	11	Small van (e.g. Econoline)	<a href="#">more</a>
V0511	Event 2 -impact Location	8	No 2nd event	<a href="#">more</a>
V0512	Event 2 -Impact Configuration	88	No 2nd event	<a href="#">more</a>
V0513	Event 2 -Object/Vehicle Contactd	00	No object/vehicle contacted	<a href="#">more</a>
V0514	Event 3 -impact Location	8	No 3rd event	<a href="#">more</a>
V0515	Event 3 -Impact Configuration	88	No 3rd event	<a href="#">more</a>
V0516	Event 3 -Object/Vehicle Contactd	00	No object/vehicle contacted	<a href="#">more</a>
V0517	Event 4 -impact Location	8	No 4th event	<a href="#">more</a>
V0518	Event 4 -Impact Configuration	88	No 4th event	<a href="#">more</a>
V0519	Event 4 -Object/Vehicle Contactd	00	No object/vehicle contacted	<a href="#">more</a>
V0520	Event 5 -impact Location	8	No 5th event	<a href="#">more</a>
V0521	Event 5 -Impact Configuration	88	No 5th event	<a href="#">more</a>
V0522	Event 5 -Object/Vehicle Contactd	00	No object/vehicle contacted	<a href="#">more</a>
V0523	Event 6 -impact Location	8	No 6th event	<a href="#">more</a>
V0524	Event 6 -Impact Configuration	88	No 6th event	<a href="#">more</a>
V0525	Event 6 -Object/Vehicle	00	No object/vehicle contacted	<a href="#">more</a>

	Contactd			
V0526	Event 7 -impact Location	8	No 7th event	<a href="#">more</a>
V0527	Event 7 -Impact Configuration	88	No 7th event	<a href="#">more</a>
V0528	Event 7 -Object/Vehicle Contactd	00	No object/vehicle contacted	<a href="#">more</a>
V0529	Primary CDC Case Vehicle - event Number	9	Unknown	<a href="#">more</a>
V0530	Primary CDC Case Vehicle - Impact Speed (kph)	999	Unknown	<a href="#">more</a>
V0531	PRIMARY CDC CASE VEHICLE - ESTIMATED BY	0	—	—
V0532	Primary CDC Case Vehicle - Crush (CM)	999	Unknown	<a href="#">more</a>
V0533	Primary CDC Case Vehicle-clock #1	99	Unknown or no damage	<a href="#">more</a>
V0534	Primary CDC Case Vehicle-Letter 1 #1	00	Missing Data/Not applicable	<a href="#">more</a>
V0535	Primary CDC Case Vehicle-Letter 2 #1	00	Missing Data/Not applicable	<a href="#">more</a>
V0536	Primary CDC Case Vehicle-Letter 3 #1	00	Missing Data/Not applicable	<a href="#">more</a>
V0537	Primary CDC Case Vehicle-Letter 4 #1	00	Missing Data/Not applicable	<a href="#">more</a>
V0538	Primary CDC Case Vehicle Extent #1	00	Missing Data/Not applicable	<a href="#">more</a>
V0539	Primary CDC - Contacted Vehicles Assoc CDC - CDC #1	0	—	—
V0540	Primary CDC Case Vehicle-clock #2	99	Unknown or no damage	<a href="#">more</a>
V0541	Primary CDC Case Vehicle-Letter 1 #2	00	Missing Data/Not applicable	<a href="#">more</a>
V0542	Primary CDC Case Vehicle-Letter 2 #2	00	Missing Data/Not applicable	<a href="#">more</a>
V0543	Primary CDC Case Vehicle-Letter 3 #2	00	Missing Data/Not applicable	<a href="#">more</a>
V0544	Primary CDC Case Vehicle-Letter 4 #2	00	Missing Data/Not applicable	<a href="#">more</a>
V0545	Primary CDC Case Vehicle Extent #2	00	Missing Data/Not applicable	<a href="#">more</a>
V0546	Primary CDC - Case Vehicle	0	—	—

	Assoc CDC - CDC #2			
V0547	Primary CDC Contacted Vehicle - Impact Speed (kph)	999	Unknown	<a href="#">more</a>
V0548	PRIMARY CDC CONTACTED VEHICLE - ESTIMATED BY	9	—	—
V0549	Primary CDC Contacted Vehicle - Crush (CM)	999	Unknown	<a href="#">more</a>
V0550	Primary CDC Contacted Vehicle-clock #1	99	Unknown or no damage	<a href="#">more</a>
V0551	Primary CDC Contacted Vehicle-Letter 1 #1	00	Missing Data/Not applicable	<a href="#">more</a>
V0552	Primary CDC Contacted Vehicle-Letter 2 #1	00	Missing Data/Not applicable	<a href="#">more</a>
V0553	Primary CDC Contacted Vehicle-Letter 3 #1	00	Missing Data/Not applicable	<a href="#">more</a>
V0554	Primary CDC Contacted Vehicle-Letter 4 #1	00	Missing Data/Not applicable	<a href="#">more</a>
V0555	Primary CDC Contacted Vehicle Extent #1	00	Missing Data/Not applicable	<a href="#">more</a>
V0556	primary CDC - Contacted Vehicles Assoc CDC - CDC #1	0	—	—
V0557	Primary CDC Contacted Vehicle-clock #2	99	Unknown or no damage	<a href="#">more</a>
V0558	Primary CDC Contacted Vehicle-Letter 1 #2	00	Missing Data/Not applicable	<a href="#">more</a>
V0559	Primary CDC Contacted Vehicle-Letter 2 #2	00	Missing Data/Not applicable	<a href="#">more</a>
V0560	Primary CDC Contacted Vehicle-Letter 3 #2	00	Missing Data/Not applicable	<a href="#">more</a>
V0561	Primary CDC Contacted Vehicle-Letter 4 #2	00	Missing Data/Not applicable	<a href="#">more</a>
V0562	Primary CDC Contacted Vehicle Extent #2	00	Missing Data/Not applicable	<a href="#">more</a>
V0563	Primary CDC - Contacted Vehicles Assoc CDC - CDC #2	0	—	—
V0564	Secondary CDC Case Vehicle-event No	8	Not applicable	<a href="#">more</a>
V0565	Secondary CDC Case Vehicle - Impact Speed (kph)	998	Not Applicable	<a href="#">more</a>
V0566	Secondary CDC Case Vehicle-estimator	8	Not applicable (no vehicle/no impact)	<a href="#">more</a>

V0567	Secondary CDC Case Vehicle - Crush (CM)	998	Not Applicable	<a href="#">more</a>
V0568	Secondary CDC Case Vehicle-clock #1	98	Not Applicable	<a href="#">more</a>
V0569	Secondary CDC Case Vehicle-Letter 1 #1	00	Missing Data/Not applicable	<a href="#">more</a>
V0570	Secondary CDC Case Vehicle-Letter 2 #1	00	Missing Data/Not applicable	<a href="#">more</a>
V0571	Secondary CDC Case Vehicle-Letter 3 #1	00	Missing Data/Not applicable	<a href="#">more</a>
V0572	Secondary CDC Case Vehicle-Letter 4 #1	00	Missing Data/Not applicable	<a href="#">more</a>
V0573	Secondary CDC Case Vehicle Extent #1	00	Missing Data/Not applicable	<a href="#">more</a>
V0574	Secondary CDC - Case Vehicle Assoc CDC - CDC #1	9800000	—	—
V0575	Secondary CDC Case Vehicle-clock #2	98	Not Applicable	<a href="#">more</a>
V0576	Secondary CDC Case Vehicle-Letter 1 #2	00	Missing Data/Not applicable	<a href="#">more</a>
V0577	Secondary CDC Case Vehicle-Letter 2 #2	00	Missing Data/Not applicable	<a href="#">more</a>
V0578	Secondary CDC Case Vehicle-Letter 3 #2	00	Missing Data/Not applicable	<a href="#">more</a>
V0579	Secondary CDC Case Vehicle-Letter 4 #2	00	Missing Data/Not applicable	<a href="#">more</a>
V0580	Secondary CDC Case Vehicle Extent #2	00	Missing Data/Not applicable	<a href="#">more</a>
V0581	Secondary CDC - Case Vehicle Assoc CDC - CDC #2	9800000	—	—
V0582	Secondary CDC Contacted Vehicle - Impact Speed (kph)	998	Not Applicable	<a href="#">more</a>
V0583	Secondary CDC Contacted Vehicle-estimator	8	Not applicable (no vehicle/no impact)	<a href="#">more</a>
V0584	Secondary CDC Contacted Vehicle - Crush (CM)	998	Not Applicable	<a href="#">more</a>
V0585	Secondary CDC Contacted Vehicle-clock #1	98	Not Applicable	<a href="#">more</a>
V0586	Secondary CDC Contacted Vehicle-Letter 1 #1	00	Missing Data/Not applicable	<a href="#">more</a>
V0587	Secondary CDC Contacted Vehicle-Letter 2 #1	00	Missing Data/Not applicable	<a href="#">more</a>

V0588	Secondary CDC Contacted Vehicle-Letter 3 #1	00	Missing Data/Not applicable	<a href="#">more</a>
V0589	Secondary CDC Contacted Vehicle-Letter 4 #1	00	Missing Data/Not applicable	<a href="#">more</a>
V0590	Secondary CDC Contacted Vehicle Extent #1	00	Missing Data/Not applicable	<a href="#">more</a>
V0591	Secondary CDC - Contacted Vehicle Assoc CDC - CDC #1	9800000	—	—
V0592	Secondary CDC Contacted Vehicle-clock #2	98	Not Applicable	<a href="#">more</a>
V0593	Secondary CDC Contacted Vehicle-Letter 1 #2	00	Missing Data/Not applicable	<a href="#">more</a>
V0594	Secondary CDC Contacted Vehicle-Letter 2 #2	00	Missing Data/Not applicable	<a href="#">more</a>
V0595	Secondary CDC Contacted Vehicle-Letter 3 #2	00	Missing Data/Not applicable	<a href="#">more</a>
V0596	Secondary CDC Contacted Vehicle-Letter 4 #2	00	Missing Data/Not applicable	<a href="#">more</a>
V0597	Secondary CDC Contacted Vehicle Extent #2	00	Missing Data/Not applicable	<a href="#">more</a>
V0598	Secondary CDC - Contacted Vehicle Assoc CDC - CDC #2	9800000	—	—

## Crash Reconstruction

[Back to Top](#)

Variable Number	Variable Name	Code Value	Code Description	Other Options
V0601	Primary Delta-V Case Vehicle-event #	1	Event number 1	<a href="#">more</a>
V0602	Primary Delta V Case Vehicle - Total Delta V	018 kph	kph	<a href="#">more</a>
V0603	Primary delta-V Case Vehicle -LONGITUD	-018	—	—
V0604	Primary delta-V Case Vehicle-Lateral	0000	—	—
V0605	Primary Delta V Case Vehicle - Energy Dissipated by Crush (k	0019	—	—
V0606	Primary Delta-V Case Vehicle-Reconstruction	22	Reconstructed, moderate confidence level	<a href="#">more</a>
V0607	Primary Delta-V Case	2	CDC & detailed damage	<a href="#">more</a>

	Vehicle- Mode			
V0608	Primary Delta V Contacted Vehicle - Total Delta V	015 kph	kph	<a href="#">more</a>
V0609	Primary delta-V Contacted Vehicle-LONGITUD	0015	—	—
V0610	Primary delta-V Contacted Vehicle-Lateral	0000	—	—
V0611	Primary delta-V Contacted Vehicle - Energy Dissipated by Cru	0013	—	—
V0612	Secondary Delta-V Case Vehicle-event #	8	Not applicable	<a href="#">more</a>
V0613	Secondary Delta V Case Vehicle - Total Delta V	888	Not applicable	<a href="#">more</a>
V0614	Secondarydelta-V Case Vehicle -LONGITUD	8888	—	—
V0615	Secondary delta-V Case Vehicle-Lateral	8888	—	—
V0616	Secondary delta-V Case Vehicle - Energy Dissipated by Crush	8888	—	—
V0617	Secondary Delta-V Case Vehicle-Reconstruction	88	Not applicable	<a href="#">more</a>
V0618	Secondary Delta-V Case Vehicle- Mode	8	Not applicable	<a href="#">more</a>
V0619	Secondary Delta V Contacted Vehicle - Total Delta V	888	Not applicable	<a href="#">more</a>
V0620	Secondary delta-V Contacted Vehicle-LONGITUD	8888	—	—
V0621	Secondary delta-V Contacted Vehicle-Lateral	8888	—	—
V0622	Secondary delta-V Contacted Vehicle - Energy Dissipated By C	8888	—	—
V0623	Primary EBS Case Vehicle-event #	1	Event number 1	<a href="#">more</a>
V0624	Primary EBS Case Vehicle - Total EBS	019 kph	kph	<a href="#">more</a>
V0625	Primary EBS Case Vehicle - LONGITUD	-019	—	—
V0626	Primary EBS Case Vehicle-Lateral	0000	—	—
V0627	Primary EBS Case Vehicle - Energy Dissipated by Crush	0019	—	—



	(kj)			
V0628	Primary EBS Case Vehicle-Reconstruction	22	Reconstructed, moderate confidence level	<a href="#">more</a>
V0629	Primary EBS Case Vehicle-Mode	2	CDC & detailed damage	<a href="#">more</a>
V0630	Primary EBS Contacted Vehicle - Total EBS	999	Unknown	<a href="#">more</a>
V0631	Primary EBS Contacted Vehicle-LONGITUD	9999	—	—
V0632	Primary EBS Contacted Vehicle-Lateral	9999	—	—
V0633	Primary EBS Contact Vehicle - Energy Dissipated by Crush (kj)	9999	—	—
V0634	Secondary EBS Case Vehicle-event #	8	Not applicable	<a href="#">more</a>
V0635	Secondary EBS Case Vehicle - Total EBS	888	Not Applicable	<a href="#">more</a>
V0636	Secondary EBS Case Vehicle -LONGITUD	8888	—	—
V0637	Secondary EBS Case Vehicle-Lateral	8888	—	—
V0638	Secondary EBS Case Vehicle - Energy Dissipated by Crush (kj)	8888	—	—
V0639	Secondary EBS Case Vehicle-Reconstruction	88	Not applicable	<a href="#">more</a>
V0640	Secondary EBS Case Vehicle- Mode	8	Not applicable	<a href="#">more</a>
V0641	Secondary EBS Contacted Vehicle - Total EBS	888	Not Applicable	<a href="#">more</a>
V0642	Secondary EBS Contacted Vehicle-LONGITUD	8888	—	—
V0643	Secondary EBS Contacted Vehicle-Lateral	8888	—	—
V0644	Secondary EBS Contact Vehicle - Energy Dissipated by Crush (	8888	—	—
V0645	Specific Event # Case(1)	1	Event number 1	<a href="#">more</a>
V0646	Plane of Impact Case Vehicle (1)	1	Bumper	<a href="#">more</a>
V0647	Direct Damage Length (DDL) - Case Vehicle (1)	094 cm	cm	<a href="#">more</a>

V0648	Direct Damage Maximum Crush - Case Vehicle (1)	019 cm	cm	<a href="#">more</a>
V0649	Direct and Induced Damage Length in CM	133 cm	cm	<a href="#">more</a>
V0650	Field C1 - Case Vehicle (1)	019 cm	cm	<a href="#">more</a>
V0651	Field C2 - Case Vehicle (1)	009 cm	cm	<a href="#">more</a>
V0652	Field C3 - Case Vehicle (1)	009 cm	cm	<a href="#">more</a>
V0653	Field C4 - Case Vehicle (1)	007 cm	cm	<a href="#">more</a>
V0654	Field C5 - Case Vehicle (1)	003 cm	cm	<a href="#">more</a>
V0655	Field C6 - Case Vehicle (1)	004 cm	cm	<a href="#">more</a>
V0656	Direct Damage D Value = The Center of Direct Damage Offset t	-026 cm	Offset (cm)	<a href="#">more</a>
V0657	Specific Event # Case(2)	1	Event number 1	<a href="#">more</a>
V0658	Plane of Impact Case Vehicle (2)	1	Bumper	<a href="#">more</a>
V0659	Direct Damage Length (DDL) - Case Vehicle (2)	094 cm	cm	<a href="#">more</a>
V0660	Direct Damage Maximum Crush - Case Vehicle (2)	019 cm	cm	<a href="#">more</a>
V0661	Direct and Induced Damage Length in CM	133 cm	cm	<a href="#">more</a>
V0662	Field C1 - Case Vehicle (2)	019 cm	cm	<a href="#">more</a>
V0663	Field C2 - Case Vehicle (2)	009 cm	cm	<a href="#">more</a>
V0664	Field C3 - Case Vehicle (2)	009 cm	cm	<a href="#">more</a>
V0665	Field C4 - Case Vehicle (2)	007 cm	cm	<a href="#">more</a>
V0666	Field C5 - Case Vehicle (2)	003 cm	cm	<a href="#">more</a>
V0667	Field C6 - Case Vehicle (2)	004 cm	cm	<a href="#">more</a>
V0668	Direct Damage D Value = The Center of Direct Damage Offset t	-026 cm	cm	<a href="#">more</a>
V0669	Specific Event # Cont(1)	1	Event number 1	<a href="#">more</a>
V0670	Plane of Impact Contacted Vehicle(1)	9	Unknown	<a href="#">more</a>
V0671	Direct Damage Length (DDL) - Contacted Vehicle (1)	999	Unknown	<a href="#">more</a>
V0672	Direct Damage Maximum Crush - Contacted Vehicle (1)	999	Unknown	<a href="#">more</a>
	Field L - Contacted Vehicle			

V0673	(1)	999	Unknown	<a href="#">more</a>
V0674	Field C1 - Contacted Vehicle (1)	999	Unknown	<a href="#">more</a>
V0675	Field C2 - Contacted Vehicle (1)	999	Unknown	<a href="#">more</a>
V0676	Field C3 - Contacted Vehicle (1)	999	Unknown	<a href="#">more</a>
V0677	Field C4 - Contacted Vehicle (1)	999	Unknown	<a href="#">more</a>
V0678	Field C5 - Contacted Vehicle (1)	999	Unknown	<a href="#">more</a>
V0679	Field C6 - Contacted Vehicle (1)	999	Unknown	<a href="#">more</a>
V0680	Direct Damage D Value = The Center of Direct Damage Offset t	+999 cm	offset (cm)	<a href="#">more</a>
V0681	Specific Event # Contacted Vehicle (2)	1	Event number	<a href="#">more</a>
V0682	Plane of Impact Contacted Vehicle(2)	9	Unknown	<a href="#">more</a>
V0683	Direct Damage Length (DDL) - Contacted Vehicle (2)	999	Unknown	<a href="#">more</a>
V0684	Direct Damage Maximum Crush - Contacted Vehicle (2)	999	Unknown	<a href="#">more</a>
V0685	Direct and Induced Damage Length in CM	999	Unknown	<a href="#">more</a>
V0686	Field C1 - Contacted Vehicle (2)	999	Unknown	<a href="#">more</a>
V0687	Field C2 - Contacted Vehicle (2)	999	Unknown	<a href="#">more</a>
V0688	Field C3 - Contacted Vehicle (2)	999	Unknown	<a href="#">more</a>
V0689	Field C4 - Contacted Vehicle (2)	999	Unknown	<a href="#">more</a>
V0690	Field C5 - Contacted Vehicle (2)	999	Unknown	<a href="#">more</a>
V0691	Field C6 - Contacted Vehicle (2)	999	Unknown	<a href="#">more</a>
V0692	Direct Damage D Value = The Center of Direct Damage Offset t	+999 cm	Offset (cm)	<a href="#">more</a>

[Back to Top](#)

## Case Vehicle Tires & Rims

Variable Number	Variable Name	Code Value	Code Description	Other Options
V0701	Left Front Wheel Damaged	1	Yes	<a href="#">more</a>
V0702	Right Front Wheel Damaged	0	No	<a href="#">more</a>
V0703	Right Rear Wheel Damaged	0	No	<a href="#">more</a>
V0704	Left Rear Wheel Damaged	0	No	<a href="#">more</a>
V0705	Left Front Tire Tread Type	4	All Weather	<a href="#">more</a>
V0706	Right Front Tire Tread Type	4	All Weather	<a href="#">more</a>
V0707	Right Rear Tire Tread Type	4	All Weather	<a href="#">more</a>
V0708	Left Rear Tire Tread Type	4	All Weather	<a href="#">more</a>
V0709	Left Front Carcass Construction	3	Radial	<a href="#">more</a>
V0710	Right Front Carcass Construction	3	Radial	<a href="#">more</a>
V0711	Right Rear Carcass Construction	3	Radial	<a href="#">more</a>
V0712	Left Rear Carcass Construction	3	Radial	<a href="#">more</a>
V0713	Left Front Tire Condition Precrash	0	Normal - no pre-crash problems	<a href="#">more</a>
V0714	Right Front Tire Condition Precrash	0	Normal - no pre-crash problems	<a href="#">more</a>
V0715	Right Rear Tire Condition Precrash	0	Normal - no pre-crash problems	<a href="#">more</a>
V0716	Left Rear Tire Condition Precrash	0	Normal - no pre-crash problems	<a href="#">more</a>
V0717	Left Front Tire Condition Postcrash	0	Normal - no damage to tire	<a href="#">more</a>
V0718	Right Front Tire Condition Postcrash	0	Normal - no damage to tire	<a href="#">more</a>
V0719	Right Rear Tire Condition Postcrash	0	Normal - no damage to tire	<a href="#">more</a>
V0720	Left Rear Tire Condition Postcrash	0	Normal - no damage to tire	<a href="#">more</a>
V0721	Left Front Tire Involvement	0	No	<a href="#">more</a>
V0722	Right Front Tire Involvement	0	No	<a href="#">more</a>

V0723	Right Rear Tire Involvement	0	No	<a href="#">more</a>
V0724	Left Rear Tire Involvement	0	No	<a href="#">more</a>
V0725	Left Front Tire Size	P215150R17	—	—
V0726	Right Front Tire Size	P215150R17	—	—
V0727	Right Rear Tire Size	P215150R17	—	—
V0728	Left Rear Tire Size	P215150R17	—	—
V0729	Left Front Tire Pressure (recorded in psi)	27.5 psi	Actual tire pressure in psi	<a href="#">more</a>
V0730	Right Front Tire Pressure (recorded in psi)	28.0 psi	Actual tire pressure in psi	<a href="#">more</a>
V0731	Right Rear Tire Pressure (recorded in psi)	28.0 psi	Actual tire pressure in psi	<a href="#">more</a>
V0732	Left Rear Tire Pressure (recorded in psi)	28.5 psi	Actual tire pressure in psi	<a href="#">more</a>
V0733	Left Front Tread Depth	04	04/32"	<a href="#">more</a>
V0734	Right Front Tread Depth	04	04/32"	<a href="#">more</a>
V0735	Right Rear Tread Depth	09	09/32"	<a href="#">more</a>
V0736	Left Rear Tread Depth	09	09/32"	<a href="#">more</a>

### Case Vehicle Fuel Tank

[Back to Top](#)

Variable Number	Variable Name	Code Value	Code Description	Other Options
V0801	Propulsive Fuel Type	1	Gasoline	<a href="#">more</a>
V0802	Main Tank Location	122	Within frame/centered laterally - within vertical	<a href="#">more</a>
V0803	Main Filler Cap Location	133	Right of frame laterally - above vertically	<a href="#">more</a>
V0804	Main Tank Material	1	Steel	<a href="#">more</a>
V0805	Aux Tank Type	8	Not applicable (not equipped)	<a href="#">more</a>
V0806	Aux Tank Location	888	Not applicable (not equipped)	<a href="#">more</a>
V0807	Aux Filler Cap Location	888	Not applicable (not equipped)	<a href="#">more</a>
V0808	Aux Tank Material	8	Not applicable	<a href="#">more</a>

### Case Vehicle Fuel Leakage

[Back to Top](#)

Variable Number	Variable Name	Code Value	Code Description	Other Options
V0901	Fuel Leakage From Crash	0	No	<a href="#">more</a>

## Case Vehicle Fire

[Back to Top](#)

Variable Number	Variable Name	Code Value	Code Description	Other Options
V1001	Fire In Or On Case Vehicle	0	No	<a href="#">more</a>

## Case Vehicle Exterior

[Back to Top](#)

Variable Number	Variable Name	Code Value	Code Description	Other Options
V1101	Hood Latch Released	1	Yes	<a href="#">more</a>
V1102	Hood Latch Damaged	1	Yes	<a href="#">more</a>
V1103	Hood Latch Jammed	0	No	<a href="#">more</a>
V1104	Left Hood Hinge Damaged	1	Yes	<a href="#">more</a>
V1105	Left Hood Hinge Separated	0	No	<a href="#">more</a>
V1106	Right Hood Hinge Damaged	1	Yes	<a href="#">more</a>
V1107	Right Hood Hinge Separated	0	No	<a href="#">more</a>
V1108	Hood Remained On Vehicle	1	Yes	<a href="#">more</a>
V1109	Rear Hood Edge Elevated	1	Yes	<a href="#">more</a>
V1110	Edge Contacted Windshield	1	Yes	<a href="#">more</a>
V1111	Edge Penetrated Windshield	0	No	<a href="#">more</a>
V1112	Hood Latch Location	1	Front of Vehicle	<a href="#">more</a>
V1113	Eng/transmissn Mount Separated	0	No	<a href="#">more</a>
V1114	Steering Column Flex Couplng	9	Unknown if equipped	<a href="#">more</a>
V1115	Steering Column Coupling Dam	9	Unknown	<a href="#">more</a>
V1116	Steering Column Coupling Separated	9	Unknown	<a href="#">more</a>
V1117	Eng Comp Telescopng Unit	88	Not currently collected	<a href="#">more</a>
V1118	Compartment Unit's Original/telescoped Length Difference	888	Not currently collected	<a href="#">more</a>
V1119	Left Side Body Mount Separated	8	Not applicable (unitized)	<a href="#">more</a>
V1120	Upper Left A-pillar Sep	0	No	<a href="#">more</a>
V1121	Lower Left A-pillar Sep	0	No	<a href="#">more</a>
V1122	Upper Left B-pillar Sep	0	No	<a href="#">more</a>

V1123	Lower Left B-pillar Sep	0	No	<a href="#">more</a>
V1124	Upper Left C-pillar Sep	0	No	<a href="#">more</a>
V1125	Lower Left C-pillar Sep	8	Not applicable (not equipped)	<a href="#">more</a>
V1126	Upper Left D-pillar Sep	8	Not applicable (not equipped)	<a href="#">more</a>
V1127	Lower Left D-pillar Sep	8	Not applicable (not equipped)	<a href="#">more</a>
V1128	Left Front Door Opening Cause	00	Door did not open	<a href="#">more</a>
V1129	Left Rear Door Opening Cause	98	Not applicable (no left rear door)	<a href="#">more</a>
V1130	Left Front Door Jammed Closed	0	No	<a href="#">more</a>
V1131	Left Rear Door Jammed Closed	8	Not applicable (no left rear door)	<a href="#">more</a>
V1132	Van Left Rear Door Type	8	Not applicable (not a van)	<a href="#">more</a>
V1133	Left Front Glazing Availability	2	Closed	<a href="#">more</a>
V1134	Left Rear Glazing Availability	1	Fixed	<a href="#">more</a>
V1135	Lr2 Glazing Availability	0	No glazing present	<a href="#">more</a>
V1136	Left Front Glazing Damage	0	No damage	<a href="#">more</a>
V1137	Left Rear Glazing Damage	0	No damage	<a href="#">more</a>
V1138	Lr2 Glazing Damage	8	Not Applicable (No Door)	<a href="#">more</a>
V1139	Rear Door Type	1	Hatchback	<a href="#">more</a>
V1140	Rear Door Opening Cause	0	Door did not open	<a href="#">more</a>
V1141	Rear Door Jammed Closed	0	No	<a href="#">more</a>
V1142	Rear Glazng Availability	1	Fixed	<a href="#">more</a>
V1143	Rear Glazing Damage	0	No damage	<a href="#">more</a>
V1144	Luggage Partition Damaged	0	No	<a href="#">more</a>
V1145	Spare Tire Status	8	Not collected	<a href="#">more</a>
V1146	Trailer Hitch Type	0	No hitch	<a href="#">more</a>
V1147	Trailer Type	0	No trailer	<a href="#">more</a>
V1148	Rght Side Body Mount Separated	8	Not applicable (unitized)	<a href="#">more</a>
V1149	Upper Right A-pillar Separated	0	No	<a href="#">more</a>
V1150	Lower Right A-pillar Separated	0	No	<a href="#">more</a>
V1151	Upper Right B-pillar Separated	0	No	<a href="#">more</a>
V1152	Lower Right B-pillar Separated	0	No	<a href="#">more</a>

V1153	Upper Right C-pillar Separated	0	No	<a href="#">more</a>
V1154	Lower Right C-pillar Separated	8	Not applicable (not equipped)	<a href="#">more</a>
V1155	Upper Right D-pillar Separated	8	Not applicable (not equipped)	<a href="#">more</a>
V1156	Lower Right D-pillar Separated	8	Not applicable (not equipped)	<a href="#">more</a>
V1157	Right Front Door Opening Cause	00	Door did not open	<a href="#">more</a>
V1158	Right Rear Door Opening Cause	98	Not applicable (no right rear door)	<a href="#">more</a>
V1159	Right Front Door Jammed Closed	0	No	<a href="#">more</a>
V1160	Right Rear Door Jammed Closed	8	Not applicable (no right rear door)	<a href="#">more</a>
V1161	Van Right-rear Door Type	8	Not applicable (not a van)	<a href="#">more</a>
V1162	Right Front Glazing Availability	2	Closed	<a href="#">more</a>
V1163	Right Rear Glazing Availability	1	Fixed	<a href="#">more</a>
V1164	Rr2 Glazing Availability	0	No glazing present	<a href="#">more</a>
V1165	Right Front Glazing Damage	0	No damage	<a href="#">more</a>
V1166	Right Rear Glazing Damage	0	No damage	<a href="#">more</a>
V1167	Rr2 Glazing Damage	8	Not Applicable (No Door)	<a href="#">more</a>
V1168	Windshield Cracked	1	Yes	<a href="#">more</a>
V1169	Windshield Broken	0	No <a href="#">Click for Windshield Damage figure</a>	<a href="#">more</a>
V1170	Occupant Cracked/Broke Wndshld	0	No	<a href="#">more</a>
V1171	Bond Separation Extent	8	Not applicable	<a href="#">more</a>
V1172	Windshield Code	97	<a href="#">Click for Windshield Mark figure</a>	<a href="#">more</a>
V1173	Did Sun Roof/T-Roof Open	0	No	<a href="#">more</a>

### Case Vehicle Steering Column/Rim

[Back to Top](#)

Variable Number	Variable Name	Code Value	Code Description	Other Options
V1201	Steering Wheel Rim Damage	0	None	<a href="#">more</a>
V1202	Number of Steering Wheel Spokes	4	4 spokes	<a href="#">more</a>



V1203	Steering Wheel Spoke Damage	0	None	<a href="#">more</a>
V1204	Steering Wheel Hub Damage	0	None	<a href="#">more</a>
V1205	Steering Wheel Location of Rim Damage	0	No damage	<a href="#">more</a>
V1206	Aftermarket Add-on Device	0	None	<a href="#">more</a>
V1207	Column Tilt Feature	3	Middle	<a href="#">more</a>
V1208	Column Swing-away Feature	0	Not equipped	<a href="#">more</a>
V1209	Column Telescoping Feature	0	Not equipped	<a href="#">more</a>
V1210	Wheel Energy Absorb Device	8	Not currently collected	<a href="#">more</a>
V1211	Wheel EA Device's original/damage Dimension Difference	888	Not collected	<a href="#">more</a>
V1212	Column Energy Absorb Device	88	Not collected	<a href="#">more</a>
V1213	Col EA Device's Orig/compressed (or Extruded) Length Diff	888	Not collected	<a href="#">more</a>
V1214	Shear Capsule Separation	888	Not collected	<a href="#">more</a>
V1215	Column Vertical Rotation	0	No apparent rotation	<a href="#">more</a>
V1216	Column Lateral Rotation	0	No apparent rotation	<a href="#">more</a>

## Case Vehicle Intrusion

[Back to Top](#)

Variable Number	Variable Name	Code Value	Code Description	Other Options
V1301	Was Occupant Compartment Intruded	1	Yes <a href="#">Click for Intrusion figure</a>	<a href="#">more</a>
V1302	Was Intrusn Catastrophic	0	No	<a href="#">more</a>
V1303	Intrusion #1	01	Intrusion Number	<a href="#">more</a>
V1304	Occupant Space Number(1)	11	First row, Left seat	<a href="#">more</a>
V1305	Intrud Component/obj (1)	03	Toe pan	<a href="#">more</a>
V1306	Associate Event Numb (1)	1	Event #1	<a href="#">more</a>
V1307	Maximum Intrusion X Axis	05 cm	Intrusion (cm)	<a href="#">more</a>
V1308	Maximum Intrusion Y Axis	00 cm	0 cm or No Intrusion	<a href="#">more</a>
V1309	Maximum Intrusion Z Axis	00 cm	0 cm or No Intrusion	<a href="#">more</a>
V1310	Occupant Number #1 (1)	00	No contact or no intrusion	<a href="#">more</a>
V1311	Injury #1 (1)	00	No injury or no intrusion	<a href="#">more</a>
V1312	Occupant Number #2 (1)	00	No contact or no intrusion	<a href="#">more</a>

V1313	Injury #2 (1)	00	No injury or no intrusion	<a href="#">more</a>
V1314	Intrusion Number #2	99	Unknown or data not collected	<a href="#">more</a>
V1315	Occupant Space Number(2)	99	Unknown or data not collected	<a href="#">more</a>
V1316	Intrud Component/obj (2)	99	Unknown or data not collected	<a href="#">more</a>
V1317	Associate Event Numb (2)	9	Unknown or data not collected	<a href="#">more</a>
V1318	Maximum Intrusion X Axis	99	Unknown or data not collected	<a href="#">more</a>
V1319	Maximum Intrusion Y Axis	99	Unknown or data not collected	<a href="#">more</a>
V1320	Maximum Intrusion Z Axis	99	Unknown or data not collected	<a href="#">more</a>
V1321	Occupant Number #1 (2)	99	Unknown or data not collected	<a href="#">more</a>
V1322	Injury #1 (2)	99	Contact, injury unknown or data not collected	<a href="#">more</a>
V1323	Occupant Number #2 (2)	99	Unknown or data not collected	<a href="#">more</a>
V1324	Injury Number #2 (2)	99	Contact, injury unknown or data not collected	<a href="#">more</a>
V1325	Intrusion Number #3	99	Unknown or data not collected	<a href="#">more</a>
V1326	Occupant Space Number(3)	99	Unknown or data not collected	<a href="#">more</a>
V1327	Intrud Compnent/obj (3)	99	Unknown or data not collected	<a href="#">more</a>
V1328	Associate Event Numb (3)	9	Unknown or data not collected	<a href="#">more</a>
V1329	Maximum Intrusion X Axis	99	Unknown or data not collected	<a href="#">more</a>
V1330	Maximum Intrusion Y Axis	99	Unknown or data not collected	<a href="#">more</a>
V1331	Maximum Intrusion Z Axis	99	Unknown or data not collected	<a href="#">more</a>
V1332	Occupant Number #1 (3)	99	Unknown or data not collected	<a href="#">more</a>
V1333	Injury #1 (3)	99	Contact, injury unknown or data not collected	<a href="#">more</a>
V1334	Occupant Number #2 (3)	99	Unknown or data not collected	<a href="#">more</a>
V1335	Injury Number #2 (3)	99	Contact, injury unknown or data not collected	<a href="#">more</a>
V1336	Intrusion Number #4	99	Unknown or data not collected	<a href="#">more</a>
V1337	Occupant Space Number(4)	99	Unknown or data not collected	<a href="#">more</a>
V1338	Intrud Component/obj (4)	99	Unknown or data not collected	<a href="#">more</a>
V1339	Associate Event Numb (4)	9	Unknown or data not collected	<a href="#">more</a>
V1340	Maximum Intrusion X Axis	99	Unknown or data not collected	<a href="#">more</a>
V1341	Maximum Intrusion Y Axis	99	Unknown or data not collected	<a href="#">more</a>
V1342	Maximum Intrusion Z Axis	99	Unknown or data not collected	<a href="#">more</a>
V1343	Occupant Number #1 (4)	99	Unknown or data not collected	<a href="#">more</a>
V1344	Injury #1 (4)	99	Contact, injury unknown or data not collected	<a href="#">more</a>
V1345	Occupant Number #2 (4)	99	Unknown or data not collected	<a href="#">more</a>
V1346	Injury Number #2 (4)	99	Contact, injury unknown or data not	<a href="#">more</a>

			collected	
V1347	Intrusion Number #5	99	Unknown or data not collected	<a href="#">more</a>
V1348	Occupant Space Number(5)	99	Unknown or data not collected	<a href="#">more</a>
V1349	Intrud Component/obj (5)	99	Unknown or data not collected	<a href="#">more</a>
V1350	Associate Event Numb (5)	9	Unknown or data not collected	<a href="#">more</a>
V1351	Maximum Intrusion X Axis	99	Unknown or data not collected	<a href="#">more</a>
V1352	Maximum Intrusion Y Axis	99	Unknown or data not collected	<a href="#">more</a>
V1353	Maximum Intrusion Z Axis	99	Unknown or data not collected	<a href="#">more</a>
V1354	Occupant Number #1 (5)	99	Unknown or data not collected	<a href="#">more</a>
V1355	Injury #1 (5)	99	Contact, injury unknown or data not collected	<a href="#">more</a>
V1356	Occupant Number #2 (5)	99	Unknown or data not collected	<a href="#">more</a>
V1357	Injury Number #2 (5)	99	Contact, injury unknown or data not collected	<a href="#">more</a>
V1358	Intrusion Number #6	99	Unknown or data not collected	<a href="#">more</a>
V1359	Occupant Space Number(6)	99	Unknown or data not collected	<a href="#">more</a>
V1360	Intrud Component/obj (6)	99	Unknown or data not collected	<a href="#">more</a>
V1361	Associate Event Numb (6)	9	Unknown or data not collected	<a href="#">more</a>
V1362	Maximum Intrusion X Axis	99	Unknown or data not collected	<a href="#">more</a>
V1363	Maximum Intrusion Y Axis	99	Unknown or data not collected	<a href="#">more</a>
V1364	Maximum Intrusion Z Axis	99	Unknown or data not collected	<a href="#">more</a>
V1365	Occupant Number #1 (6)	99	Unknown or data not collected	<a href="#">more</a>
V1366	Injury #1 (6)	99	Contact, injury unknown or data not collected	<a href="#">more</a>
V1367	Occupant Number #2 (6)	99	Unknown or data not collected	<a href="#">more</a>
V1368	Injury Number #2 (6)	99	Contact, injury unknown or data not collected	<a href="#">more</a>
V1369	Intrusion Number #7	99	Unknown or data not collected	<a href="#">more</a>
V1370	Occupant Space Number(7)	99	Unknown or data not collected	<a href="#">more</a>
V1371	Intrud Component/obj (7)	99	Unknown or data not collected	<a href="#">more</a>
V1372	Associate Event Numb (7)	9	Unknown or data not collected	<a href="#">more</a>
V1373	Maximum Intrusion X Axis	99	Unknown or data not collected	<a href="#">more</a>
V1374	Maximum Intrusion Y Axis	99	Unknown or data not collected	<a href="#">more</a>
V1375	Maximum Intrusion Z Axis	99	Unknown or data not collected	<a href="#">more</a>
V1376	Occupant Number #1 (7)	99	Unknown or data not collected	<a href="#">more</a>
V1377	Injury #1 (7)	99	Contact, injury unknown or data not collected	<a href="#">more</a>
V1378	Occupant Number #2 (7)	99	Unknown or data not collected	<a href="#">more</a>
V1379	Injury Number #2 (7)	99	Contact, injury unknown or data not	<a href="#">more</a>

			collected	
V1380	Intrusion Number #8	99	Unknown or data not collected	<a href="#">more</a>
V1381	Occupant Space Number(8)	99	Unknown or data not collected	<a href="#">more</a>
V1382	Intrud Component/obj (8)	99	Unknown or data not collected	<a href="#">more</a>
V1383	Associate Event Numb (8)	9	Unknown or data not collected	<a href="#">more</a>
V1384	Maximum Intrusion X Axis	99	Unknown or data not collected	<a href="#">more</a>
V1385	Maximum Intrusion Y Axis	99	Unknown or data not collected	<a href="#">more</a>
V1386	Maximum Intrusion Z Axis	99	Unknown or data not collected	<a href="#">more</a>
V1387	Occupant Number #1 (8)	99	Unknown or data not collected	<a href="#">more</a>
V1388	Injury #1 (8)	99	Contact, injury unknown or data not collected	<a href="#">more</a>
V1389	Occupant Number #2 (8)	99	Unknown or data not collected	<a href="#">more</a>
V1390	Injury #2 (8)	99	Contact, injury unknown or data not collected	<a href="#">more</a>
V1391	Intrusion Number #9	99	Unknown or data not collected	<a href="#">more</a>
V1392	Occupant Space Number(9)	99	Unknown or data not collected	<a href="#">more</a>
V1393	Intrud Component/obj (9)	99	Unknown or data not collected	<a href="#">more</a>
V1394	Associate Event Numb (9)	9	Unknown or data not collected	<a href="#">more</a>
V1395	Maximum Intrusion X Axis	99	Unknown or data not collected	<a href="#">more</a>
V1396	Maximum Intrusion Y Axis	99	Unknown or data not collected	<a href="#">more</a>
V1397	Maximum Intrusion Z Axis	99	Unknown or data not collected	<a href="#">more</a>
V1398	Occupant Number #1 (9)	99	Unknown or data not collected	<a href="#">more</a>
V1399	Injury #1 (9)	99	Contact, injury unknown or data not collected	<a href="#">more</a>
V1400	Occupant Number #2 (9)	99	Unknown or data not collected	<a href="#">more</a>
V1401	Injury Number #2 (9)	99	Contact, injury unknown or data not collected	<a href="#">more</a>
V1402	Intrusion Number #10	99	Unknown or data not collected	<a href="#">more</a>
V1403	Occupant Space Number (10)	99	Unknown or data not collected	<a href="#">more</a>
V1404	Intrud Component/obj(10)	99	Unknown or data not collected	<a href="#">more</a>
V1405	Associate Event Numb(10)	9	Unknown or data not collected	<a href="#">more</a>
V1406	Maximum Intrusion X Axis	99	Unknown or data not collected	<a href="#">more</a>
V1407	Maximum Intrusion Y Axis	99	Unknown or data not collected	<a href="#">more</a>
V1408	Maximum Intrusion Z Axis	99	Unknown or data not collected	<a href="#">more</a>
V1409	Occupant Number #1 (10)	99	Unknown or data not collected	<a href="#">more</a>
V1410	Injury #1 (10)	99	Contact, injury unknown or data not collected	<a href="#">more</a>
V1411	Occupant Number #2 (10)	99	Unknown or data not collected	<a href="#">more</a>
V1412	Injury Number #2 (10)	99	Contact, injury unknown or data not	<a href="#">more</a>

			collected	
V1413	Intrusion Number (a)	88	Not Applicable	<a href="#">more</a>
V1414	Cause Of Intrusion (a)	8	Not applicable	<a href="#">more</a>
V1415	Intrusion Number (b)	88	Not Applicable	<a href="#">more</a>
V1416	Cause Of Intrusion (b)	8	Not applicable	<a href="#">more</a>
V1417	Intrusion Number (c)	88	Not Applicable	<a href="#">more</a>
V1418	Cause Of Intrusion (c)	8	Not applicable	<a href="#">more</a>
V1419	Intrusion Number (a)	88	Not Applicable	<a href="#">more</a>
V1420	Damaged Component 1 (a)	8	Not Applicable	<a href="#">more</a>
V1421	Damaged Component 2 (a)	8	Not Applicable	<a href="#">more</a>
V1422	Intrusion Number (b)	88	Not Applicable	<a href="#">more</a>
V1423	Damaged Component 1 (b)	8	Not Applicable	<a href="#">more</a>
V1424	Damaged Component 2 (b)	8	Not Applicable	<a href="#">more</a>
V1425	Intrusion Number (c)	88	Not Applicable	<a href="#">more</a>
V1426	Damaged Component 1 (c)	8	Not Applicable	<a href="#">more</a>
V1427	Damaged Component 2 (c)	8	Not Applicable	<a href="#">more</a>
V1428	Intrusion Number (d)	88	Not Applicable	<a href="#">more</a>
V1429	Damaged Component 1 (d)	8	Not Applicable	<a href="#">more</a>
V1430	Damaged Component 2 (d)	8	Not Applicable	<a href="#">more</a>

### Case Vehicle Airbag(s)

[Back to Top](#)

Variable Number	Variable Name	Code Value	Code Description	Other Options
V1501	Driver Airbag Equipped	1	Yes <a href="#">Click for Driver Airbag figure</a>	<a href="#">more</a>
V1502	Right Front Airbag Equip	1	Yes <a href="#">Click for Passenger Airbag figure</a>	<a href="#">more</a>
V1503	Left Rear Airbag Equipped	0	No	<a href="#">more</a>
V1504	Right Rear Airbag Equipped	0	No	<a href="#">more</a>
V1505	Driver Airbag Deployed	1	Yes	<a href="#">more</a>
V1506	Rght Front Airbag Deploy	1	Yes	<a href="#">more</a>
V1507	Left Rear Airbag Deploy	8	Not applicable (no airbag)	<a href="#">more</a>
V1508	Rught Rear Airbag Deploy	8	Not applicable (no airbag)	<a href="#">more</a>
V1509	Driver On/off Switch	0	Not equipped (no switch)	<a href="#">more</a>
V1510	Rght Front On/off Switch	0	Not equipped (no switch)	<a href="#">more</a>
V1511	Left Rear On/off Switch	8	Not applicable (no airbag)	<a href="#">more</a>
V1512	Right Rear On/off Switch	8	Not applicable (no airbag)	<a href="#">more</a>
V1513	Driver Airbag Location	1	Steering wheel	<a href="#">more</a>
V1514	Right Front Airbag Location	2	Top instrument panel	<a href="#">more</a>

V1515	Left Rear Airbag Location	0	No airbag	<a href="#">more</a>
V1516	Right Rear Airbag Location	0	No airbag	<a href="#">more</a>
V1517	Driver Airbag Condition	0	No damage	<a href="#">more</a>
V1518	Right Front Airbag Condition	0	No damage	<a href="#">more</a>
V1519	Left Rear Airbag Condition	8	Not applicable (not equipped / not deployed)	<a href="#">more</a>
V1520	Right Rear Airbag Condition	8	Not applicable (not equipped / not deployed)	<a href="#">more</a>
V1521	Driver Airbag Tether	1	Yes	<a href="#">more</a>
V1522	Right Front Airbag Tether	1	Yes	<a href="#">more</a>
V1523	Left Rear Airbag Tether	8	Not applicable	<a href="#">more</a>
V1524	Right Rear Airbag Tether	8	Not applicable	<a href="#">more</a>
V1525	Driver Marked By Contact	1	Yes	<a href="#">more</a>
V1526	Right Front Marked By Contact	0	No	<a href="#">more</a>
V1527	Left Rear Marked By Contact	8	Not applicable (no airbag / not deployed)	<a href="#">more</a>
V1528	Right Rear Marked By Contact	8	Not applicable (no airbag / not deployed)	<a href="#">more</a>
V1529	Driver Module Type	1	H-pattern flaps	<a href="#">more</a>
V1530	Right Front Module Type	8	Other	<a href="#">more</a>
V1531	Left Rear Module Type	0	No airbag present	<a href="#">more</a>
V1532	Right Rear Module Type	0	No airbag present	<a href="#">more</a>
V1533	Driver Module Cover Dam.	1	Flaps not damaged / marked	<a href="#">more</a>
V1534	Right Front Module Cover Dam.	1	Flaps not damaged / marked	<a href="#">more</a>
V1535	Left Rear Module Cover Dam.	0	No airbag	<a href="#">more</a>
V1536	Right Rear Module Cover Dam.	0	No airbag	<a href="#">more</a>
V1537	Driver Airbag Type	1	Original equipment	<a href="#">more</a>
V1538	Right Front Airbag Type	1	Original equipment	<a href="#">more</a>
V1539	Left Rear Airbag Type	0	No airbag	<a href="#">more</a>
V1540	Right Rear Airbag Type	0	No airbag	<a href="#">more</a>
V1541	Driver Airbag Vents	2	Vents present	<a href="#">more</a>
V1542	Right Front Airbag Vents	2	Vents present	<a href="#">more</a>
V1543	Left Rear Airbag Vents	0	No airbag	<a href="#">more</a>
V1544	Right Rear Airbag Vents	0	No airbag	<a href="#">more</a>
V1545	Driver Knee Bolster Equipped	0	No	<a href="#">more</a>

V1546	Right Front Knee Bolster Equipped	0	No	<a href="#">more</a>
V1547	Left Rear Knee Bolster Equipped	0	No	<a href="#">more</a>
V1548	Right Rear Knee Bolster Equipped	0	No	<a href="#">more</a>
V1549	Driver Knee Bolster Deploy	8	Not applicable (no airbag)	<a href="#">more</a>
V1550	Right Front Knee Bolster Deploy	8	Not applicable (no airbag)	<a href="#">more</a>
V1551	Left Rear Knee Bolster Deploy	8	Not applicable (no airbag)	<a href="#">more</a>
V1552	Right Rear Knee Bolster Deploy	8	Not applicable (no airbag)	<a href="#">more</a>
V1553	Left Front Number of Tethers	4	Tethers	<a href="#">more</a>
V1554	Left Front Number of Vents	2	Vents	<a href="#">more</a>
V1555	Right Front Number of Tethers	2	Tethers	<a href="#">more</a>
V1556	Right Front Number of Vents	1	Vents	<a href="#">more</a>
V1557	Left Rear Number of Tethers	8	Not applicable (no airbag)	<a href="#">more</a>
V1558	Left Rear Number of Vents	8	Not applicable (no airbag)	<a href="#">more</a>
V1559	Right Rear Number of Tethers	8	Not applicable (no airbag)	<a href="#">more</a>
V1560	Right Rear Number of Vents	8	Not applicable (no airbag)	<a href="#">more</a>

## Case Vehicle Interior

[Back to Top](#)

Variable Number	Variable Name	Code Value	Code Description	Other Options
V1601	Left Front Door Damaged	0	No	<a href="#">more</a>
V1602	Right Front Door Damaged	0	No	<a href="#">more</a>
V1603	Left Front Hardware Damaged	0	No	<a href="#">more</a>
V1604	Right Front Hardware Damaged	0	No	<a href="#">more</a>
V1605	Left Front Armrest Damaged	0	No	<a href="#">more</a>
V1606	Right Front Armrest Damaged	0	No	<a href="#">more</a>
V1607	Left Front Glass Damaged	0	No	<a href="#">more</a>
V1608	Right Front Glass Damaged	0	No	<a href="#">more</a>
V1609	Left Rear Door Area Damaged	0	No	<a href="#">more</a>

V1610	Right Rear Door Area Damaged	0	No	<a href="#">more</a>
V1611	Left Rear Hardware Damaged	0	No	<a href="#">more</a>
V1612	Right Rear Hardware Damaged	0	No	<a href="#">more</a>
V1613	Left Rear Armrest Damaged	0	No	<a href="#">more</a>
V1614	Right Rear Armrest Damaged	0	No	<a href="#">more</a>
V1615	Left Rear Glass Damaged	0	No	<a href="#">more</a>
V1616	Right Rear Glass Damaged	0	No	<a href="#">more</a>
V1617	Left Roof Side Rail Damaged	0	No	<a href="#">more</a>
V1618	Right Roof Side Rail Damaged	0	No	<a href="#">more</a>
V1619	Left B-pillar Damaged	0	No	<a href="#">more</a>
V1620	Right B-pillar Damaged	0	No	<a href="#">more</a>
V1621	Left C-pillar Damaged	0	No	<a href="#">more</a>
V1622	Right C-pillar Damaged	0	No	<a href="#">more</a>
V1623	Left D-pillar Damaged	8	Not applicable	<a href="#">more</a>
V1624	Right D-pillar Damaged	8	Not applicable	<a href="#">more</a>
V1625	Left Headlining Damaged	0	No	<a href="#">more</a>
V1626	Right Headlining Damaged	0	No	<a href="#">more</a>
V1627	Left Roof Structure Damaged	0	No	<a href="#">more</a>
V1628	Right Roof Structure Damaged	0	No	<a href="#">more</a>
V1629	Left T/sun Roof Damaged	0	No	<a href="#">more</a>
V1630	Right T/sun Roof Damaged	0	No	<a href="#">more</a>
V1631	Other Left Side Item Damagd	8	Not applicable	<a href="#">more</a>
V1632	Other Right Side Item Damagd	8	Not applicable	<a href="#">more</a>
V1633	Foot Controls Damaged	0	No	<a href="#">more</a>
V1634	Ignition Key Damaged	0	No	<a href="#">more</a>
V1635	Rear View Mirror Damaged	0	No	<a href="#">more</a>
V1636	Sunvisor/fitting Damaged	0	No	<a href="#">more</a>
V1637	Windshld Molding Damaged	0	No	<a href="#">more</a>
V1638	Left A-pillar Damaged	0	No	<a href="#">more</a>
V1639	Right A-pillar Damaged	0	No	<a href="#">more</a>
V1640	Console Damaged	1	Yes	<a href="#">more</a>
V1641	Transmissn Lever Damaged	0	No	<a href="#">more</a>
V1642	Horn/spoke Shroud Damagd	0	No	<a href="#">more</a>



V1643	Upper Panel Damaged	0	No	<a href="#">more</a>
V1644	Mid Panel Damaged	0	No	<a href="#">more</a>
V1645	Lower Panel Damaged	0	No	<a href="#">more</a>
V1646	Ashtray Damaged	0	No	<a href="#">more</a>
V1647	Control Knob/lever Damaged	0	No	<a href="#">more</a>
V1648	Glove Compart Area Damaged	0	No	<a href="#">more</a>
V1649	Instruments Damaged	0	No	<a href="#">more</a>
V1650	Park Brake Release Damaged	0	No	<a href="#">more</a>
V1651	Park Brake Pedal Damaged	0	No	<a href="#">more</a>
V1652	A/c Or Upper Vent Damagd	0	No	<a href="#">more</a>
V1653	Heater Or A/c Duct Damaged	0	No	<a href="#">more</a>
V1654	Radio Damaged	0	No	<a href="#">more</a>
V1655	Other Front Item Damaged	8	Not applicable	<a href="#">more</a>
V1656	Rear Backlight Damaged	0	No	<a href="#">more</a>
V1657	Backlight Header Damaged	0	No	<a href="#">more</a>
V1658	Vertical Console Damaged	0	No	<a href="#">more</a>
V1659	Roof Console Damaged	0	No	<a href="#">more</a>

## Case Vehicle Seats

[Back to Top](#)

Variable Number	Variable Name	Code Value	Code Description	Other Options
V1701	Driver Front Seat Type	05	Bucket	<a href="#">more</a>
V1702	Passenger Front Seat Type	05	Bucket	<a href="#">more</a>
V1703	Driver Seat Mount Type	1	Standard	<a href="#">more</a>
V1704	Passenger Seat Mount Type	1	Standard	<a href="#">more</a>
V1705	Driver Swivel Mech Equipped	0	No	<a href="#">more</a>
V1706	Passenger Swivel Mech Equipped	0	No	<a href="#">more</a>
V1707	Driver Seat Original Equipment	1	Yes	<a href="#">more</a>
V1708	Passenger Seat Original Equipment	1	Yes	<a href="#">more</a>
V1709	Driver Seat/rear Oc Contct	8	Not applicable	<a href="#">more</a>
V1710	Passenger Seat/rear Oc Contct	8	Not applicable	<a href="#">more</a>
V1711	Driver Seat Damage	0	None	<a href="#">more</a>
V1712	Passenger Seat Damage	0	None	<a href="#">more</a>

V1713	Cntr Frnt Armrest Damagd	0	No	<a href="#">more</a>
V1714	Driver Seat-back Rotation	0	None apparent	<a href="#">more</a>
V1715	Passenger Seat-back Rotation	0	None apparent	<a href="#">more</a>
V1716	Driver Seat-back Type	3	Reclining	<a href="#">more</a>
V1717	Passenger Seat-back Type	3	Reclining	<a href="#">more</a>
V1718	Driver Seat-back Lock Type	3	Power	<a href="#">more</a>
V1719	Passenger Seat-back Lock Type	1	Manual	<a href="#">more</a>
V1720	Driver Seat-back Lock Held	1	Yes	<a href="#">more</a>
V1721	Passenger Seat-back Lock Held	1	Yes	<a href="#">more</a>
V1722	Driver Recliner Mech Held	1	Yes	<a href="#">more</a>
V1723	Passenger Recliner Mech Held.	1	Yes	<a href="#">more</a>
V1724	Driver Head Restraint Type	1	Adjustable	<a href="#">more</a>
V1725	Passenger Head Restraint Type	1	Adjustable	<a href="#">more</a>
V1726	Driver Head Rest Removed	0	No	<a href="#">more</a>
V1727	Passenger Head Rest Removed	0	No	<a href="#">more</a>
V1728	Driver Head Rest Adjustmnt	2	Down	<a href="#">more</a>
V1729	Passenger Head Rest Adjustmnt	2	Down	<a href="#">more</a>
V1730	Driver Head Rest Damage	0	None	<a href="#">more</a>
V1731	Passenger Head Rest Damage	0	None	<a href="#">more</a>
V1732	Driver Rear Impact Counter	0	None	<a href="#">more</a>
V1733	Passenger Rear Impact Counter	0	None	<a href="#">more</a>
V1734	Driver Seat Adjustmnt Type	2	Power	<a href="#">more</a>
V1735	Passenger Seat Adjustmnt Type	1	Manual	<a href="#">more</a>
V1736	Driver Seat Adjust Provisn	2	4-way	<a href="#">more</a>
V1737	Passenger Seat Adjust Provisn	1	2-way	<a href="#">more</a>
V1738	Driver Seat Adjuster Dam	0	None	<a href="#">more</a>
V1739	Passenger Seat Adjuster Dam	0	None	<a href="#">more</a>
V1740	Driver Seat Adjuster Sep	8	Not applicable	<a href="#">more</a>
V1741	Passenger Seat Adjuster Sep	8	Not applicable	<a href="#">more</a>
V1742	Driver Seat Pre-crash Pos	3	Rearward	<a href="#">more</a>
V1743	Passenger Seat Pre-crash Pos	2	Middle	<a href="#">more</a>

V1744	Left Rear Seat Type	2	Folding	<a href="#">more</a>
V1745	Rght Rear Seat Type	2	Folding	<a href="#">more</a>
V1746	Left Rear Seat Damage	0	None	<a href="#">more</a>
V1747	Rght Rear Seat Damage	0	None	<a href="#">more</a>
V1748	Cntr Rear Armrest Damagd	8	Not applicable	<a href="#">more</a>
V1749	Left Rear Seat-back Left Lock Equipped	1	Yes	<a href="#">more</a>
V1750	Right Rear Seat-back Left Lock Equipped	0	No	<a href="#">more</a>
V1751	Left Rear Seat-back Left Lock Held	1	Yes	<a href="#">more</a>
V1752	Right Rear Seat-back Left Lock Held	8	Not applicable	<a href="#">more</a>
V1753	Left Rear Seat-back Right Lock Equipped	0	No	<a href="#">more</a>
V1754	Right Rear Seat-back Right Lock Equipped	1	Yes	<a href="#">more</a>
V1755	Left Rear Seat-back Right Lock Held	8	Not applicable	<a href="#">more</a>
V1756	Right Rear Seat-back Right Lock Held	1	Yes	<a href="#">more</a>
V1757	Left 3rd Seat Equipped	0	No	<a href="#">more</a>
V1758	Right 3rd Seat Equipped	0	No	<a href="#">more</a>
V1759	Left 3rd Row Type Seat	0	None	<a href="#">more</a>
V1760	Right 3rd Row Type Seat	0	None	<a href="#">more</a>
V1761	Left 3rd Seat Damage	8	Not applicable	<a href="#">more</a>
V1762	Right 3rd Seat Damage	8	Not applicable	<a href="#">more</a>
V1763	Left 3rd Seat Cushion Dam	8	Not applicable	<a href="#">more</a>
V1764	Right 3rd Seat Cushion Dam	8	Not applicable	<a href="#">more</a>
V1765	Left 3rd Seat L/c Lock Equipped	8	Not applicable	<a href="#">more</a>
V1766	Right 3rd Seat L/c Lock Equipped	8	Not applicable	<a href="#">more</a>
V1767	Left 3rd Seat L/c Lock Held	8	Not applicable	<a href="#">more</a>
V1768	Right 3rd Seat L/c Lock Held	8	Not applicable	<a href="#">more</a>
V1769	Left 3rd Seat Right Lock Equipped	8	Not applicable	<a href="#">more</a>
V1770	Right 3rd Seat Right Lock Equipped	8	Not applicable	<a href="#">more</a>
V1771	Left 3rd Seat Right Lock Held	8	Not applicable	<a href="#">more</a>

V1772	Right 3rd Seat Right Lock Held	8	Not applicable	<a href="#">more</a>
V1773	Rear Head Restraints	1	Equipped	<a href="#">more</a>

### Case Vehicle Side Airbag(s)

[Back to Top](#)

Variable Number	Variable Name	Code Value	Code Description	Other Options
V1801	Side Airbag Equipped	1	Yes, equipped	<a href="#">more</a>
V1802	Left Front Seatback Mount Deploy	2	Not deployed	<a href="#">more</a>
V1803	Right Front Seatback Mount Deploy	2	Not deployed	<a href="#">more</a>
V1804	Left Rear Seatback Mount Deploy	0	Not equipped	<a href="#">more</a>
V1805	Right Rear Seatback Mount Deploy	0	Not equipped	<a href="#">more</a>
V1806	Left Front Seatback Module Type	3	Not deployed	<a href="#">more</a>
V1807	Right Front Seatback Module Type	3	Not deployed	<a href="#">more</a>
V1808	Left Rear Seatback Module Type	0	Not equipped	<a href="#">more</a>
V1809	Right Rear Seatback Module Type	0	Not equipped	<a href="#">more</a>
V1810	Left Front Seatback Airbag Type	5	Not deployed	<a href="#">more</a>
V1811	Right Front Seatback Airbag Type	5	Not deployed	<a href="#">more</a>
V1812	Left Rear Seatback Airbag Type	0	Not equipped	<a href="#">more</a>
V1813	Right Rear Seatback Airbag Type	0	Not equipped	<a href="#">more</a>
V1814	Left Front Seatback Airbag Cond.	8	Not deployed	<a href="#">more</a>
V1815	Right Front Seatback Airbag Cond.	8	Not deployed	<a href="#">more</a>
V1816	Left Rear Seatback Airbag Cond.	0	Not equipped	<a href="#">more</a>
V1817	Right Rear Seatback Airbag Cond.	0	Not equipped	<a href="#">more</a>
V1818	Left Front Door-mounted Deploy	0	Not equipped	<a href="#">more</a>

V1819	Right Front Door-mounted Deploy	0	Not equipped	<a href="#">more</a>
V1820	Left Rear Door-mounted Deploy	0	Not equipped	<a href="#">more</a>
V1821	Right Rear Door-mounted Deploy	0	Not equipped	<a href="#">more</a>
V1822	Left Front Door Module Type	0	Not equipped	<a href="#">more</a>
V1823	Right Front Door Module Type	0	Not equipped	<a href="#">more</a>
V1824	Left Rear Door Module Type	0	Not equipped	<a href="#">more</a>
V1825	Right Rear Door Module Type	0	Not equipped	<a href="#">more</a>
V1826	Left Front Door Airbag Type	0	Not equipped	<a href="#">more</a>
V1827	Right Front Door Airbag Type	0	Not equipped	<a href="#">more</a>
V1828	Left Rear Door Airbag Type	0	Not equipped	<a href="#">more</a>
V1829	Right Rear Door Airbag Type	0	Not equipped	<a href="#">more</a>
V1830	Left Front Door Airbag Condition	0	Not equipped	<a href="#">more</a>
V1831	Right Front Door Airbag Condition	0	Not equipped	<a href="#">more</a>
V1832	Left Rear Door Airbag Condition	0	Not equipped	<a href="#">more</a>
V1833	Right Rear Door Airbag Condition	0	Not equipped	<a href="#">more</a>
V1834	Left Front Roof Mounted Deploy	0	Not equipped	<a href="#">more</a>
V1835	Right Front Roof Mounted Deploy	0	Not equipped	<a href="#">more</a>
V1836	Left Rear Roof Mounted Deploy	0	Not equipped	<a href="#">more</a>
V1837	Right Rear Roof Mounted Deploy	0	Not equipped	<a href="#">more</a>
V1838	Left Front Roof Module Type	0	Not equipped	<a href="#">more</a>
V1839	Right Front Roof Module Type	0	Not equipped	<a href="#">more</a>
V1840	Left Rear Roof Module Type	0	Not equipped	<a href="#">more</a>
V1841	Right Rear Roof Module Type	0	Not equipped	<a href="#">more</a>
V1842	Left Front Roof Airbag Type	0	Not equipped	<a href="#">more</a>

V1843	Right Front Roof Airbag Type	0	Not equipped	<a href="#">more</a>
V1844	Left Rear Roof Airbag Type	0	Not equipped	<a href="#">more</a>
V1845	Right Rear Roof Airbag Type	0	Not equipped	<a href="#">more</a>
V1846	Left Front Roof Airbag Condition	0	Not equipped	<a href="#">more</a>
V1847	Right Front Roof Airbag Condition	0	Not equipped	<a href="#">more</a>
V1848	Left Rear Roof Airbag Condition	0	Not equipped	<a href="#">more</a>
V1849	Right Rear Roof Airbag Condition	0	Not equipped	<a href="#">more</a>

### EDR -- Event Data Recorder

[Back to Top](#)

Variable Number	Variable Name	Code Value	Code Description	Other Options
V1901	Case Vehicle EDR Equipped	0	Not equipped	<a href="#">more</a>
V1902	Type Of File Recovered	0	Not equipped	<a href="#">more</a>
V1903	EDR Pre-crash Braking	0	Not equipped	<a href="#">more</a>
V1904	Event Data Recorder (EDR) Pre-impact Speed	91	Not equipped	<a href="#">more</a>
V1905	EDR Driver Belt Status	0	Not equipped	<a href="#">more</a>
V1906	EDR Right Front Belt Status	0	Not equipped	<a href="#">more</a>
V1907	Right Front Airbag Suppressed	0	Not equipped	<a href="#">more</a>
V1908	Sir Warning Lamp Status	0	Not equipped	<a href="#">more</a>
V1909	Time Between Near Deployment and Deployment (in Seconds)	0	Not equipped	<a href="#">more</a>
V1910	Time Between Algorithm Enable and Deployment (in ms)	000	Not equipped	<a href="#">more</a>
V1911	Maximum Recorded Longitudinal Velocity Change (mph)	000	No time / not collected	<a href="#">more</a>
V1912	Maximum Recorded Lateral Velocity Change (mph)	000	No time / not collected	<a href="#">more</a>
V1913	More Than One Deploy?	0	Not equipped	<a href="#">more</a>

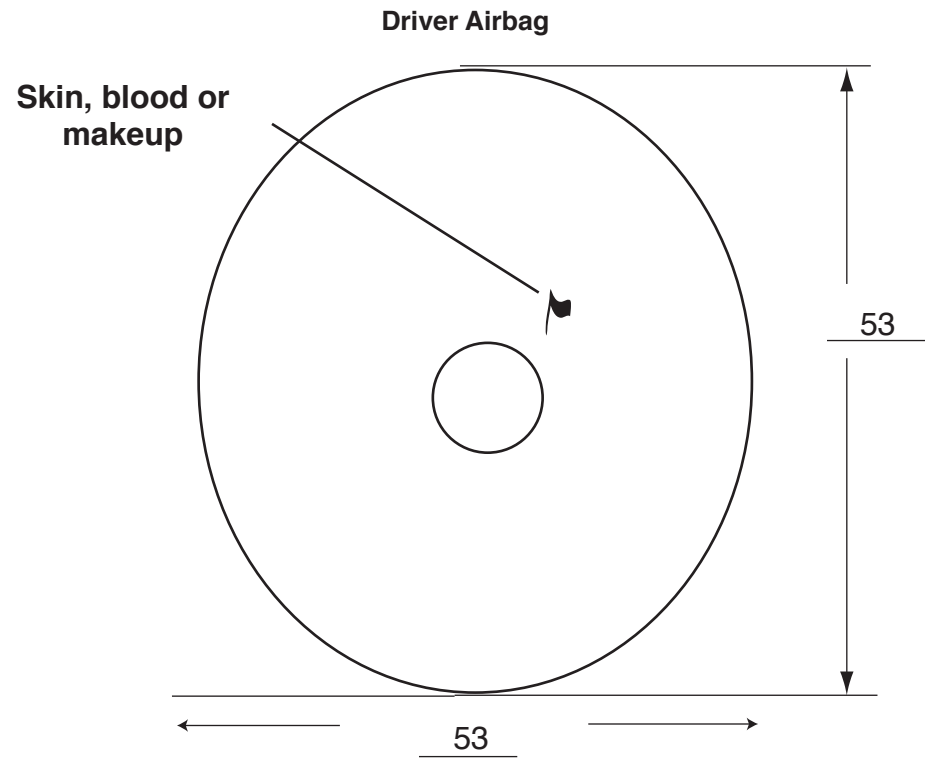

Vents:  Y  N  
 if yes, how many: 2  
 vents @ 11 and 1 o'clock

Tethers:  Y  N  
 if yes, how many: 4

**Driver Airbag Doors**

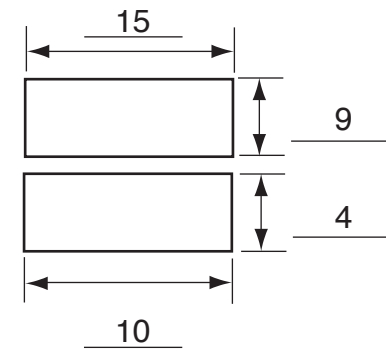

H-Pattern

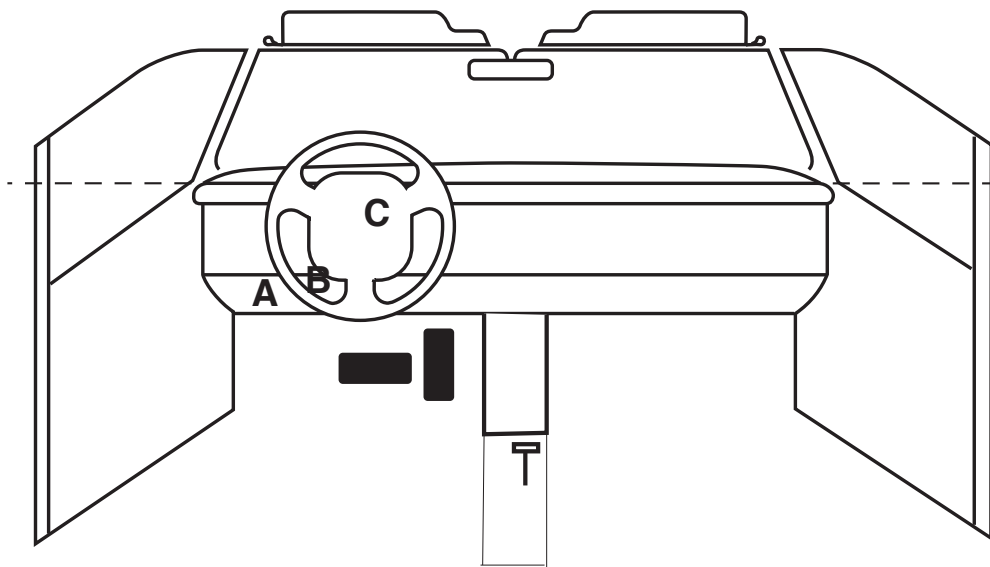

**A = knee bolster, scuffs**

**B = tilt steering-wheel adjustment lever, skin deposit**

**C = airbag, skin, blood or makeup deposit**



**Dash-mounted module cover damage**

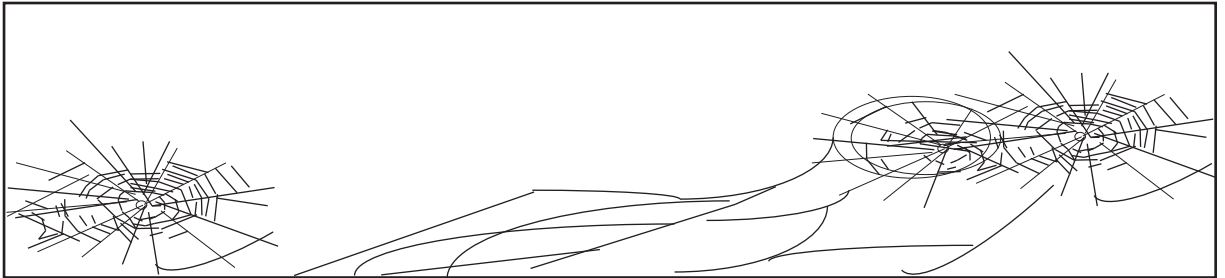

**Contact by rear edge of hood**

WINDSHIELD MARK ON CASE VEHICLE:



Ⓟ **Carlite** Ⓡ  
SOLAR TINT  
LAMINATED AS1  
??R-004569  
??T-28? VF-M569

MEASUREMENTS IN CENTIMETERS

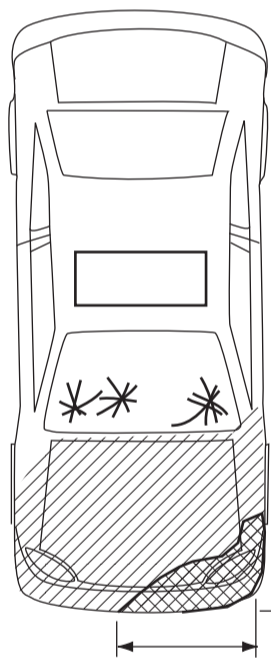
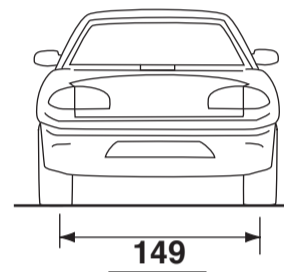
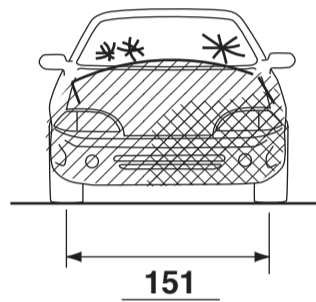

Width of direct damage to front

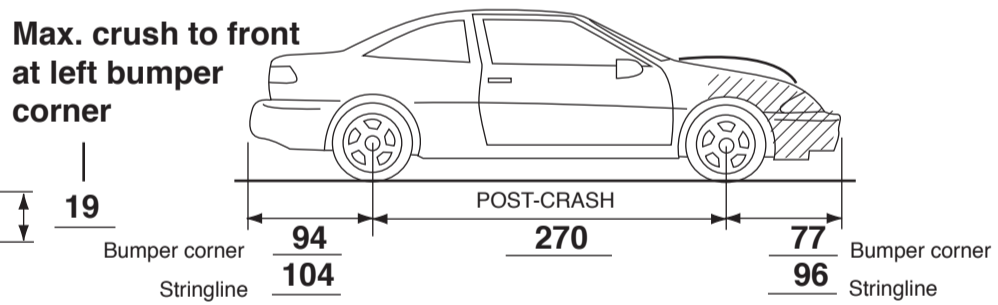
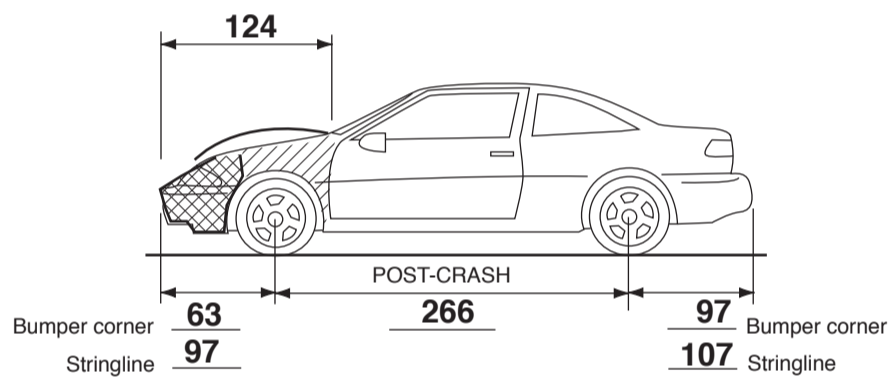

MEASUREMENTS IN CENTIMETERS  
**VEHICLE NOT INSPECTED**

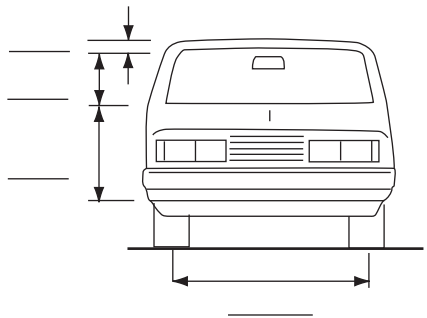

Original  
 Bumper Height

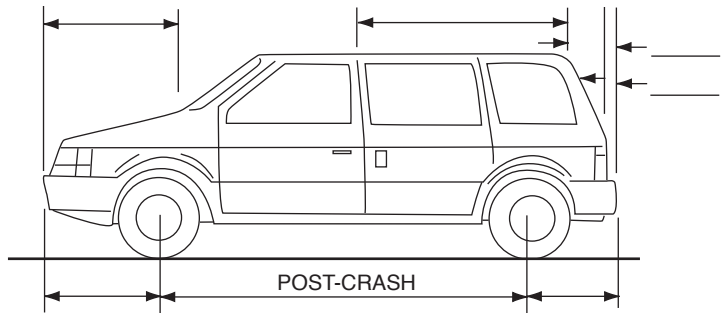
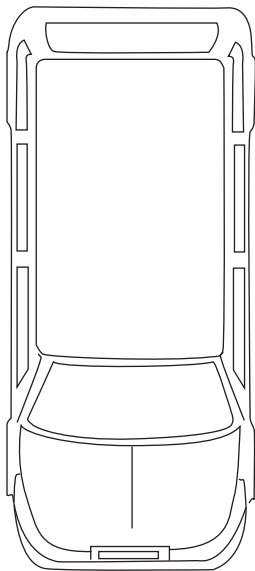
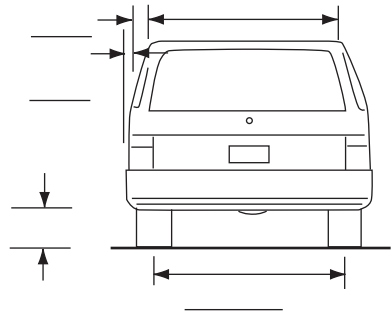

Bumper corner \_\_\_\_\_  
 Stringline \_\_\_\_\_

\_\_\_\_\_ Bumper corner  
 \_\_\_\_\_ Stringline

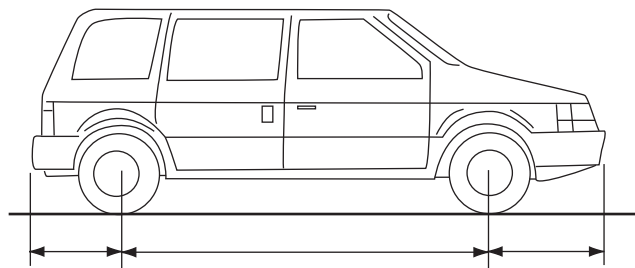

Bumper corner \_\_\_\_\_  
 Stringline \_\_\_\_\_

\_\_\_\_\_ Bumper corner  
 \_\_\_\_\_ Stringline

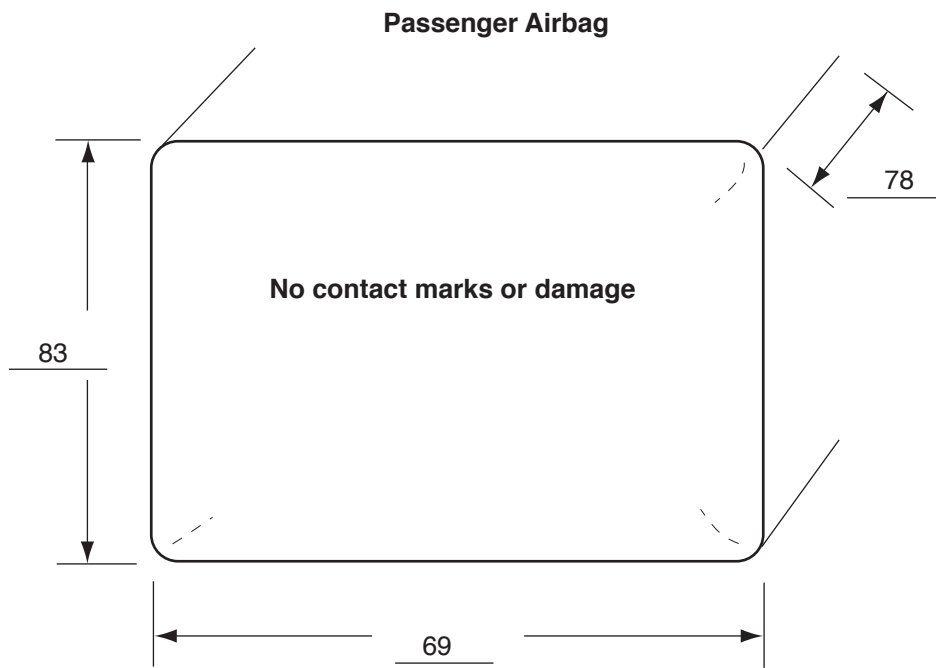

**Passenger Airbag Door**  
Single Door

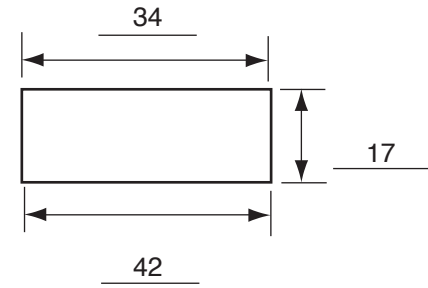

Vents:  Y N  
if yes, how many: 1  
Vent @ 10 o'clock

Tethers:  Y N  
if yes, how many: 2













**WARNING**  
DO NOT REMOVE LABEL OR COVER  
SEE USER MANUAL FOR DETAILS







AIRBAG







**WARNING**  
SMOKING IS DANGEROUS  
BECAUSE IT CAN CAUSE A FIRE OR EXPLOSION.  
DO NOT SMOKE IN THE VEHICLE.  
DO NOT USE OPEN FLAMES OR CIGARETTES.  
DO NOT USE FLAMMABLE LIQUIDS.  
DO NOT USE FLAMMABLE SOLIDS.  
DO NOT USE FLAMMABLE GASES.  
DO NOT USE FLAMMABLE POWDERS.  
DO NOT USE FLAMMABLE LIQUIDS.  
DO NOT USE FLAMMABLE SOLIDS.  
DO NOT USE FLAMMABLE GASES.  
DO NOT USE FLAMMABLE POWDERS.

1 11111  
2 22222  
3 33333  
4 44444  
5 55555  
6 66666  
7 77777  
8 88888  
9 99999  
0 00000  
+ + + + +  
- - - - -  
\* \* \* \* \*













57321

PROTECTION

















AIRBAG



AIRBAG











74391

COUGAR





DO NOT  
REMOVE  
EVIDENCE  
UNTIL  
NOTIFIED

774391

281





774391  
SF  
BK  
200  
H

180281





80281

774391

V6



Department  
of Public Safety

774391

774391













RAM 1500

10281

774391

V6













