

Case 472 : Narrative

Case Vehicle (A): 2000 Mercury	Vehicle (B): 1998 Nissan
Type: Grand Marquis GS, 4-door sedan	Type: Pathfinder, 4x4, 4-door SUV
Driver: 67-year-old male	Driver: 17-year-old female
CDC: 12-FDEW-1	CDC: 99-0000-0

SITUATION

1 It was daylight and cloudy and the asphalt road surface at the intersection of the five-lane divided highway and the two-lane crossover turn-lane was dry and free of defects. 2 Case vehicle (A) was traveling southeast at an unknown speed in the left lane of the highway where it curves to the left and 3 vehicle (B) was stopped facing southwest in the crossover turn-lane. As case vehicle (A) approached the turn-lane, vehicle (B) moved forward into the highway lanes to travel west and it entered the path of case vehicle (A). The driver of case vehicle (A) braked and steered to the right but was unable to avoid a collision, and the front of case vehicle (A) struck the right side of vehicle (B). After the impact, vehicle (B) rolled one-quarter turn and came to rest on its left side, facing southwest. Both vehicles were towed due to damage.

The police accident report (PAR) indicates C-level injuries for the right-front passenger of case vehicle (A) and for the driver of vehicle (B). The right-front passenger of case vehicle (A) was transported by ambulance to a local hospital and hospitalized for two days. The driver of vehicle (B) was treated at the scene. The PAR indicates O-level injuries for the driver of case vehicle (A), who was not treated.

GENERAL VEHICLE DAMAGE AND ESTIMATED CRASH SEVERITIES

4 Damage to the front of case vehicle (A) was minor. 5 Direct damage began at the left-front bumper corner and extended to the right across the entire frontal plane. The maximum crush was 9 cm and it occurred at the left-front bumper corner.

Vehicle (B) was not available for inspection.

Using the missing-vehicle algorithm of the WinSMASH crash-reconstruction program and 6 7 8 crush values measured at the level of the bumper for case vehicle (A), the following impact severities were estimated:

		Estimated Velocity Change - kph (mph)		
Vehicle	Variable	Total	Longitudinal	Latitudinal
Case Vehicle (A)	delta V	16 (10)	-15 (-10)	3 (2)
Vehicle (B)	delta V	16 (10)	-3 (-2)	-16 (-10)

DESCRIPTION OF DAMAGE TO CASE VEHICLE (A)

Exterior

[9](#) [10](#) In the front, the bumper, the grill, the upper radiator support, and the hood were crushed rearward, and the center of the hood was buckled up. The hood latch was damaged and jammed closed, but there was no damage to the hood hinges. The rear edge of the hood was not elevated and it did not contact the undamaged windshield.

[11](#) [12](#) On the left side, the forward section of the fender was scuffed and crushed slightly rearward. Both left-side doors remained closed and operational and all the left-side glazing was intact. There was no other left-side damage but the left wheelbase was reduced by 2 cm.

There was no damage to the rear of the vehicle.

[13](#) On the right side, the rear section of the fender was buckled in. Both right-side doors were closed and operational and all the right-side glazing was intact. There was no other right-side damage but the right wheelbase was increased by 5 cm.

Interior

This vehicle was equipped with steering-wheel and dash-mounted frontal-impact airbags and [14](#) [15](#) both deployed during the frontal impact. In the driver area, there was no damage to the to the steering-wheel airbag [16](#) [17](#) [18](#) but the module cover/flap was scuffed. [19](#) The left edge of the knee bolster was scuffed, the hood-release handle was not attached, and [20](#) the underside of the steering-column cover was scuffed. [21](#) [22](#) [23](#) [24](#) [25](#) [26](#) [27](#) There was no other damage in the driver area.

[28](#) There was no damage in the center-front area and [29](#) [30](#) [31](#) [32](#) there was no damage in the right-front seating area.

[33](#) [34](#) There was no damage in the rear seating areas and there were no intrusions into the interior of the vehicle.

OCCUPANT KINEMATICS AND INJURIES

[35](#) The 180-cm, 95-kg (5-ft 11-in, 210-lb) 67-year-old male driver was using the three-point belt and [36](#) the steering-wheel airbag deployed. [37](#) There were no loading marks on the D-ring [38](#) but there was melted plastic on the belt webbing near the D-ring and [39](#) [40](#) there were webbing imprints on the plastic sliding latch plate, indicating belt use at the time of the crash. During the frontal impact, the driver moved forward relative to the vehicle interior, into the three-point belt and airbag, but he did not sustain any injuries.

[41](#) The 160-cm, 75-kg (5-ft 3-in, 165-lb) 63-year-old female right-front passenger was using the three-point belt and [42](#) the dash-mounted airbag deployed. [43](#) There were no loading marks on the D-ring or sliding latch plate [44](#) but the belt webbing was stretched indicating belt use. Just before the impact the right-front passenger turned her head to the right and her lips brushed against the shoulder belt, [45](#) [46](#) as indicated by lipstick on the shoulder-belt webbing. The seat was adjusted to the rearmost seat-track position.

During the frontal impact, the right-front passenger moved forward relative to the vehicle interior, into the three-point belt and airbag. She sustained a contusion across the upper-right chest, a cardiac

contusion, and fractures to left ribs 6 through 9 due to loading by the shoulder belt.

The following tables and drawings [47](#) [48](#) summarize the injuries for the two occupants of case vehicle (A).

Occupant: Driver	Age: 67 years	Gender: Male		
Restraints: 3-point belt; steering-wheel airbag	Stature: 180 cm (5 ft, 11 in)	Mass: 95 kg (210 lb)		
Injury Description	A.I.S.	Injury Source		
		Definite	Probable	Possible
—	—	—	—	—
No injury	—	—	—	—
Maximum A.I.S. Level	0	—	—	—
Injury Severity Score	0	—	—	—

Occupant: Right front	Age: 63 years	Gender: Female		
Restraints: 3-point belt; dash-mounted airbag	Stature: 160 cm (5 ft, 3 in)	Mass: 75 kg (165 lb)		
Injury Description	A.I.S.	Injury Source		
		Definite	Probable	Possible
—	—	—	—	—
Contusion across upper-right chest	1	Shoulder belt	—	—
Cardiac contusion	1	Shoulder belt	—	—
Fractures, left ribs 6 through 9	3	Shoulder belt	—	—
Maximum A.I.S. Level	3	—	—	—
Injury Severity Score	10	—	—	—

CASE NO.: 472

CASE VEHICLE: 2000 Mercury

TYPE: Grand Marquis GS, 4-door sedan

OCCUPANT: Driver: 67-year-old male

STATURE: 180 cm (5 ft, 11 in) MASS: 95 kg (210 lb)

RESTRAINTS: 3-point belt; steering-wheel airbag

SEVERITY: MAIS - 0 : ISS - 0

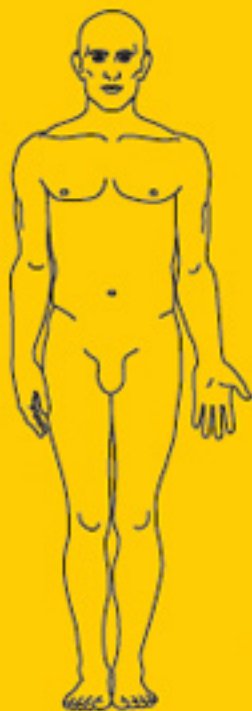

No injury



CASE NO.: 472

CASE VEHICLE: 2000 Mercury

TYPE: Grand Marquis GS, 4-door sedan

OCCUPANT: Right front: 63-year-old female

STATURE: 160 cm (5 ft, 3 in) MASS: 75 kg (165 lb)

RESTRAINTS: 3-point belt; dash-mounted airbag

SEVERITY: MAIS - 3 : ISS - 10

Contusion, across right
upper chest (1)



Cardiac contusion (1)

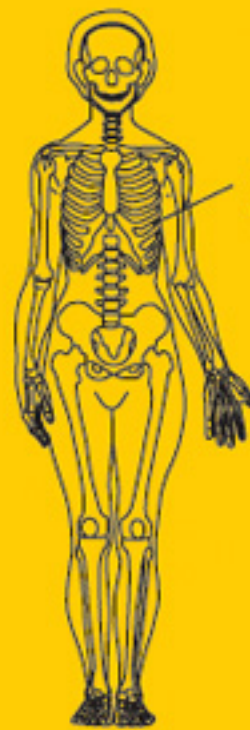

Fractures, left ribs
6-9 (3)

Case No.: **472**
Case Veh. (A): **2000 Mercury**
Type: **Grand Marquis GS, 4-door sedan**
Driver: **67-year-old male**
Veh. (B): **1998 Nissan Pathfinder, 4x4, 4-door SUV**

Light Conditions: **Daylight**
Weather: **Cloudy**
Road Surface: **Dry**
Road Construction: **Asphalt**

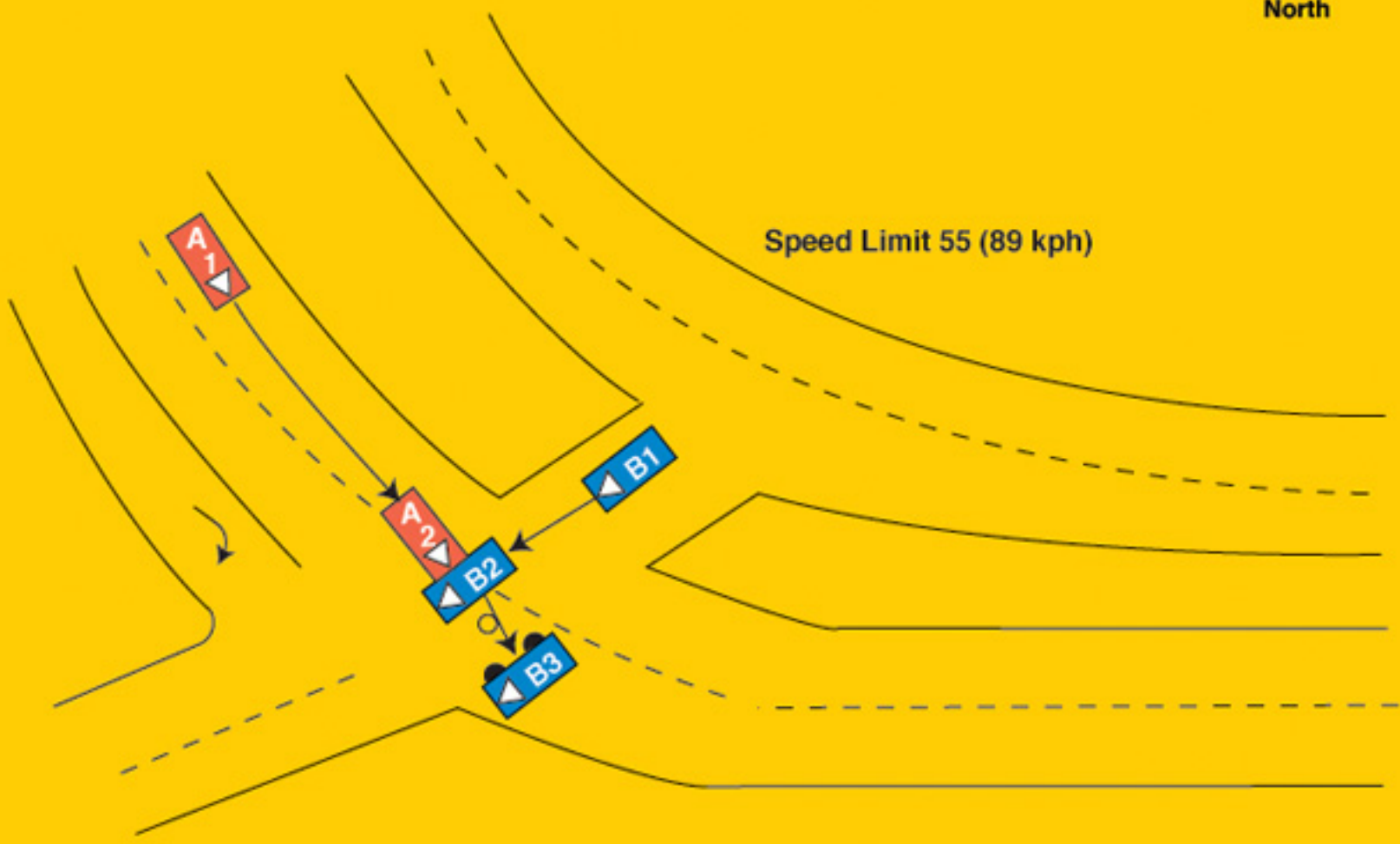

472: Vehicle Report

Click on Section Name to jump directly to that Section —

- [General Information](#)
- [Other Vehicle](#)
- [Case Vehicle General](#)
- [Case Vehicle Damage Description](#)
- [Crash Reconstruction](#)
- [Case Vehicle Tires & Rims](#)
- [Case Vehicle Fuel Tank](#)
- [Case Vehicle Fuel Leakage](#)
- [Case Vehicle Fire](#)
- [Case Vehicle Exterior](#)
- [Case Vehicle Steering Column/Rim](#)
- [Case Vehicle Intrusion](#)
- [Case Vehicle Airbag\(s\)](#)
- [Case Vehicle Interior](#)
- [Case Vehicle Seats](#)
- [Case Vehicle Side Airbag\(s\)](#)
- [EDR -- Event Data Recorder](#)

General Information

[Back to Top](#)

Variable Number	Variable Name	Code Value	Code Description	Other Options
V0204	Collision Hour	1130	Time of day (24 hour clock)	more
V0205	State Fips Code	26	Michigan	more
V0206	Urban/rural Area	2	Rural	more
V0207	Limited Access Highway	0	No	more
V0208	Road Total Lanes	5	Divided, 4 lanes or more	more
V0209	Intersect Road Total Lanes	2	2 lanes	more
V0210	Trafficway Flow	1	Divided trafficway - median strip without positi	more
V0211	Road Surface Type	1	Asphalt	more
V0212	Road Defects	0	No	more
V0213	Construction Zone	0	No	more
	Road Alignment Vertical			

V0214	Plane	1	Level	more
V0215	Road Alignment Horizontal Plane	2	Curve	more
V0216	Surface Covering	10	Dry	more
V0217	Visibility Limitation	0	None	more
V0218	Visibility Obstruction	0	None	more
V0219	Speed Limit	6	86-90 km/h .. 55 mph	more
V0220	Precipitation Type	0	None	more
V0221	Precipitation Rate	8	Not applicable	more
V0222	Temperature	9	Unknown	more
V0223	Crosswind	9	Unknown	more
V0224	Light Conditions	1	Daylight	more
V0225	Mechanical Malfunction Mention	0	No	more
V0226	Case Vehicle And Object	0	No	more
V0227	Case Vehicle Rollover	0	No	more
V0228	Rollover Location	0	No rollover	more
V0229	Roll Direction	0	No rollover	more
V0230	Rollover Initiation Type	0	No rollover	more
V0231	Rollover Number Of Turns	0	No rollover	more
V0232	Case Vehicle Preimpact Braking	1	Yes	more
V0233	Case Vehicle Preimpact Stability	1	Case vehicle tracking before impact	more
V0234	Case Vehicle Ran Off Roadway	0	No	more
V0235	Moving Case Vehicle Contacted Moving Vehicle	1	Yes	more
V0236	Case Vehicle Contacted Stopped Vehicle	0	No	more
V0237	Stopped Case Vehicle Contacted Vehicle	0	No	more
V0238	Total Vehicles Hit By Case Vehicle	1	1 vehicle	more
V0239	Any Fire In Crash?	0	No	more
V0240	Maximum Police Severity-acc	1	C - Possible Injury	more
V0241	Driver Alcohol Involvmnt	0	Had not been drinking	more
V0242	Driver Alcohol BAC (Case Vehicle)	80	No test	more
V0243	Driver Impairment Mention	0	No	more

V0244	Driver Distraction	01	Attentive or not distracted	more
V0245	Driver Drug Involvement	0	None	more
V0246	Driver Drug Type	0	No drug use	more
V0247	Driven/towed From Scene	2	Towed Due to Damage	more

Other Vehicle

[Back to Top](#)

Variable Number	Variable Name	Code Value	Code Description	Other Options
V0301	Other Vehicle VIN	JN8AR05Y3WXXXXXXXX	Click for Contacted Vehicle figure	more
V0302	Other Vehicle Manufacturer/Body Code	86114	—	—
V0303	Other Vehicle Manufacturer	861	Nissan (Datsun)	more
V0304	Other Vehicle Body Code	14	Short wheelbase utility vehicle (Jeep, Bronco)	more
V0305	Other Vehicle Make/model	1550	Pathfinder	more
V0306	Other Vehicle Model Year	1998	Year	more
V0307	Other Vehicle Mass	001803 kg	Mass (Kg.)	more
V0308	Other Vehicle Number	0	No separate report	more
V0309	Other Vehicle Number of Occupants	01	number of occupants	more
V0310	Other Vehicle Traveling Speed	995	Just starting	more
V0311	Highest Police Injury Severity	1	C - Possible Injury	more
V0312	Other Vehicle Type	14	Small utility (wheelbase <107", e.g. Jeep)	more
V0313	Other Vehicle Wheelbase in Centimeters	270 cm	Actual Wheelbase (cm)	more
V0314	Other Vehicle Average Track Width	149 cm	actual measurement (cm)	more
V0315	Other Vehicle Overall Length	453 cm	actual measurement (cm)	more
V0316	Other Vehicle Overall Width (OAW)	174 cm	actual measurement (cm)	more
V0317	Other Vehicle Front	078 cm	actual measurement (cm)	more

	Overhang			
V0318	Other Vehicle Rear Overhang	106 cm	actual measurement (cm)	more
V0319	Other Vehicle Undeformed End Width (UEW)	146 cm	actual measurement (cm)	more
V0320	Other Vehicle Engine Displacement	3.3 l	Liters	more
V0321	Other Vehicle Engine: Number of Cylinders	06	number of cylinders	more
V0322	Other Vehicle Direct Damage Length (DDL)	999	Unknown	more
V0323	Other Vehicle Front-End Overlap	99	Missing or Not applicable	more
V0324	Other Vehicle - Vehicle Overlap	99	Missing or Not applicable	more

Case Vehicle General

[Back to Top](#)

Variable Number	Variable Name	Code Value	Code Description	Other Options
V0401	VIN	2MEFM74W7YXXXXXXX	Click for Case Vehicle figure	more
V0402	Manufacturer/Body Code	22229	—	—
V0403	Vehicle Manufacturer	222	Lincoln-Mercury	more
V0404	Vehicle Body Code	29	Full 110-114.9 in. wb.	more
V0405	Make/model Code	0929	Grand Marquis	more
V0406	Model Year	2000	Model year	more
V0407	Vehicle Mass	001796 kg	Mass (Kg)	more
V0408	Odometer Reading	135238	—	—
V0409	Number of Occupants	02	2 occupants	more
V0410	Traveling Speed	999	Unknown	more
V0411	Body Type	14	4-door sedan	more
V0412	Stolen Vehicle	8	Not currently collected	more
V0413	Body Structure	1	Body and frame	more
V0414	Transmission Type	1	Automatic	more
V0415	Transmission Lever Location	3	Column	more
V0416	Steering	1	Power	more
V0417	Brakes	1	Power	more
V0418	Brake Type	3	Disc - all wheels	more

V0419	Adjustable Pedals?	0	No	more
V0420	Brake Anti-lock Device	0	None installed	more
V0421	Air Conditioning in Vehicle	8	Not currently collected	more
V0422	Drive Type	1	Rear wheel	more
V0423	Dual Rear Wheels	0	No	more
V0424	Original Restraint System Type	3	Air bag	more
V0425	Equipped With Roll Bar	0	No	more
V0426	Roof Type	1	Solid	more
V0427	Case Vehicle Wheelbase in Centimeters	291 cm	Actual Wheelbase	more
V0428	Anti-lacerative Glass	8	Not Collected	more
V0429	Case Vehicle average track Width	163 cm	actual measurement (cm)	more
V0430	Case Vehicle Overall Length	538 cm	actual measurement (cm)	more
V0431	Case Vehicle Overall Width (OAW)	199	actual measurement (cm)	more
V0432	Case Vehicle Front Overhang	108 cm	actual measurement (cm)	more
V0433	Case Vehicle Rear Overhang	139 cm	actual measurement (cm)	more
V0434	Case Vehicle Undeformed End Width (UEW)	155 cm	actual measurement (cm)	more
V0435	Case Vehicle Engine Displacement	4.6 l	Liters	more
V0436	Case Vehicle Engine: Number of Cylinders	08	number of cylinders	more
V0437	Case Vehicle Direct Damage Length (DDL)	155 cm	actual measurement (cm)	more
V0438	Case Vehicle Front-end Overlap	98	98% or more	more
V0439	Case Vehicle - Vehicle Overlap	98	98% or more	more

Case Vehicle Damage Description

[Back to Top](#)

Variable	Variable Name	Code	Code Description	Other
----------	---------------	------	------------------	-------

Number		Value		Options
V0501	Maximum Sheet Metal Crush - Front	009 cm	Depth of Crush (cm)	more
V0502	Maximum Sheet Metal Crush - Right Side	000 cm	No Crush (or less than 1 cm.)	more
V0503	Maximum Sheet Metal Crush - Rear	000 cm	No Crush (or less than 1 cm.)	more
V0504	Maximum Sheet Metal Crush - Left Side	000 cm	No Crush (or less than 1 cm.)	more
V0505	Maximum Sheet Metal Crush - Roof	000 cm	No Crush (or less than 1 cm.)	more
V0506	Maximum Sheet Metal Crush - Other	000 cm	No Crush (or less than 1 cm.)	more
V0507	Seq In Chronological Ord	1	Yes	more
V0508	Event 1 -impact Location	1	On Roadway	more
V0509	Event 1 -Impact Configuration	13	FRONT of case veh - SIDE of contacted veh	more
V0510	Event 1 -Object/Vehicle Contactd	14	Small utility (wheelbase <107", e.g. Jeep)	more
V0511	Event 2 -impact Location	8	No 2nd event	more
V0512	Event 2 -Impact Configuration	88	No 2nd event	more
V0513	Event 2 -Object/Vehicle Contactd	00	No object/vehicle contacted	more
V0514	Event 3 -impact Location	8	No 3rd event	more
V0515	Event 3 -Impact Configuration	88	No 3rd event	more
V0516	Event 3 -Object/Vehicle Contactd	00	No object/vehicle contacted	more
V0517	Event 4 -impact Location	8	No 4th event	more
V0518	Event 4 -Impact Configuration	88	No 4th event	more
V0519	Event 4 -Object/Vehicle Contactd	00	No object/vehicle contacted	more
V0520	Event 5 -impact Location	8	No 5th event	more
V0521	Event 5 -Impact Configuration	88	No 5th event	more
V0522	Event 5 -Object/Vehicle Contactd	00	No object/vehicle contacted	more
V0523	Event 6 -impact Location	8	No 6th event	more
V0524	Event 6 -Impact Configuration	88	No 6th event	more

V0525	Event 6 -Object/Vehicle Contactd	00	No object/vehicle contacted	more
V0526	Event 7 -impact Location	8	No 7th event	more
V0527	Event 7 -Impact Configuration	88	No 7th event	more
V0528	Event 7 -Object/Vehicle Contactd	00	No object/vehicle contacted	more
V0529	Primary CDC Case Vehicle - event Number	1	Event 1	more
V0530	Primary CDC Case Vehicle - Impact Speed (kph)	999	Unknown	more
V0531	Primary CDC Case Vehicle- estimatr	1	Investigator	more
V0532	Primary CDC Case Vehicle - Crush (CM)	009	Crush measurements in cm	more
V0533	Primary CDC Case Vehicle- clock #1	12	12 o'clock	more
V0534	Primary CDC Case Vehicle- Letter 1 #1	06	F - Front	more
V0535	Primary CDC Case Vehicle- Letter 2 #1	04	D - Distributed (Side or End)	more
V0536	Primary CDC Case Vehicle- Letter 3 #1	05	E - Everything below belt line	more
V0537	Primary CDC Case Vehicle- Letter 4 #1	23	W - Wide impact area	more
V0538	Primary CDC Case Vehicle Extent #1	01	Extent 1	more
V0539	Primary CDC - Contacted Vehicles Assoc CDC - CDC #1	12FDEW1	—	—
V0540	Primary CDC Case Vehicle- clock #2	98	Not Applicable	more
V0541	Primary CDC Case Vehicle- Letter 1 #2	00	Missing Data/Not applicable	more
V0542	Primary CDC Case Vehicle- Letter 2 #2	00	Missing Data/Not applicable	more
V0543	Primary CDC Case Vehicle- Letter 3 #2	00	Missing Data/Not applicable	more
V0544	Primary CDC Case Vehicle- Letter 4 #2	00	Missing Data/Not applicable	more
V0545	Primary CDC Case Vehicle Extent #2	00	Missing Data/Not applicable	more
V0546	Primary CDC - Case Vehicle	9800000	—	—

	Assoc CDC - CDC #2			
V0547	Primary CDC Contacted Vehicle - Impact Speed (kph)	999	Unknown	more
V0548	Primary CDC Contacted Vehicle-estimator	1	Investigator	more
V0549	Primary CDC Contacted Vehicle - Crush (CM)	999	Unknown	more
V0550	Primary CDC Contacted Vehicle-clock #1	99	Unknown or no damage	more
V0551	Primary CDC Contacted Vehicle-Letter 1 #1	00	Missing Data/Not applicable	more
V0552	Primary CDC Contacted Vehicle-Letter 2 #1	00	Missing Data/Not applicable	more
V0553	Primary CDC Contacted Vehicle-Letter 3 #1	00	Missing Data/Not applicable	more
V0554	Primary CDC Contacted Vehicle-Letter 4 #1	00	Missing Data/Not applicable	more
V0555	Primary CDC Contacted Vehicle Extent #1	00	Missing Data/Not applicable	more
V0556	primary CDC - Contacted Vehicles Assoc CDC - CDC #1	99000000	—	—
V0557	Primary CDC Contacted Vehicle-clock #2	99	Unknown or no damage	more
V0558	Primary CDC Contacted Vehicle-Letter 1 #2	00	Missing Data/Not applicable	more
V0559	Primary CDC Contacted Vehicle-Letter 2 #2	00	Missing Data/Not applicable	more
V0560	Primary CDC Contacted Vehicle-Letter 3 #2	00	Missing Data/Not applicable	more
V0561	Primary CDC Contacted Vehicle-Letter 4 #2	00	Missing Data/Not applicable	more
V0562	Primary CDC Contacted Vehicle Extent #2	00	Missing Data/Not applicable	more
V0563	Primary CDC - Contacted Vehicles Assoc CDC - CDC #2	99000000	—	—
V0564	Secondary CDC Case Vehicle-event No	8	Not applicable	more
V0565	Secondary CDC Case Vehicle - Impact Speed (kph)	998	Not Applicable	more
V0566	Secondary CDC Case Vehicle-estimator	8	Not applicable (no vehicle/no impact)	more

V0567	Secondary CDC Case Vehicle - Crush (CM)	998	Not Applicable	more
V0568	Secondary CDC Case Vehicle-clock #1	98	Not Applicable	more
V0569	Secondary CDC Case Vehicle-Letter 1 #1	00	Missing Data/Not applicable	more
V0570	Secondary CDC Case Vehicle-Letter 2 #1	00	Missing Data/Not applicable	more
V0571	Secondary CDC Case Vehicle-Letter 3 #1	00	Missing Data/Not applicable	more
V0572	Secondary CDC Case Vehicle-Letter 4 #1	00	Missing Data/Not applicable	more
V0573	Secondary CDC Case Vehicle Extent #1	00	Missing Data/Not applicable	more
V0574	Secondary CDC - Case Vehicle Assoc CDC - CDC #1	9800000	—	—
V0575	Secondary CDC Case Vehicle-clock #2	98	Not Applicable	more
V0576	Secondary CDC Case Vehicle-Letter 1 #2	00	Missing Data/Not applicable	more
V0577	Secondary CDC Case Vehicle-Letter 2 #2	00	Missing Data/Not applicable	more
V0578	Secondary CDC Case Vehicle-Letter 3 #2	00	Missing Data/Not applicable	more
V0579	Secondary CDC Case Vehicle-Letter 4 #2	00	Missing Data/Not applicable	more
V0580	Secondary CDC Case Vehicle Extent #2	00	Missing Data/Not applicable	more
V0581	Secondary CDC - Case Vehicle Assoc CDC - CDC #2	9800000	—	—
V0582	Secondary CDC Contacted Vehicle - Impact Speed (kph)	998	Not Applicable	more
V0583	Secondary CDC Contacted Vehicle-estimator	8	Not applicable (no vehicle/no impact)	more
V0584	Secondary CDC Contacted Vehicle - Crush (CM)	998	Not Applicable	more
V0585	Secondary CDC Contacted Vehicle-clock #1	98	Not Applicable	more
V0586	Secondary CDC Contacted Vehicle-Letter 1 #1	00	Missing Data/Not applicable	more
V0587	Secondary CDC Contacted Vehicle-Letter 2 #1	00	Missing Data/Not applicable	more

V0588	Secondary CDC Contacted Vehicle-Letter 3 #1	00	Missing Data/Not applicable	more
V0589	Secondary CDC Contacted Vehicle-Letter 4 #1	00	Missing Data/Not applicable	more
V0590	Secondary CDC Contacted Vehicle Extent #1	00	Missing Data/Not applicable	more
V0591	Secondary CDC - Contacted Vehicle Assoc CDC - CDC #1	9800000	—	—
V0592	Secondary CDC Contacted Vehicle-clock #2	98	Not Applicable	more
V0593	Secondary CDC Contacted Vehicle-Letter 1 #2	00	Missing Data/Not applicable	more
V0594	Secondary CDC Contacted Vehicle-Letter 2 #2	00	Missing Data/Not applicable	more
V0595	Secondary CDC Contacted Vehicle-Letter 3 #2	00	Missing Data/Not applicable	more
V0596	Secondary CDC Contacted Vehicle-Letter 4 #2	00	Missing Data/Not applicable	more
V0597	Secondary CDC Contacted Vehicle Extent #2	00	Missing Data/Not applicable	more
V0598	Secondary CDC - Contacted Vehicle Assoc CDC - CDC #2	9800000	—	—

Crash Reconstruction

[Back to Top](#)

Variable Number	Variable Name	Code Value	Code Description	Other Options
V0601	Primary Delta-V Case Vehicle-event #	1	Event number 1	more
V0602	Primary Delta V Case Vehicle - Total Delta V	016 kph	kph	more
V0603	Primary delta-V Case Vehicle -LONGITUD	-015	—	—
V0604	Primary delta-V Case Vehicle-Lateral	0003	—	—
V0605	Primary Delta V Case Vehicle - Energy Dissipated by Crush (k	0015	—	—
V0606	Primary Delta-V Case Vehicle-Reconstruction	22	Reconstructed, moderate confidence level	more
V0607	Primary Delta-V Case	2	CDC & detailed damage	more

	Vehicle- Mode			
V0608	Primary Delta V Contacted Vehicle - Total Delta V	016 kph	kph	more
V0609	Primary delta-V Contacted Vehicle-LONGITUD	-003	—	—
V0610	Primary delta-V Contacted Vehicle-Lateral	-016	—	—
V0611	Primary delta-V Contacted Vehicle - Energy Dissipated by Cru	0023	—	—
V0612	Secondary Delta-V Case Vehicle-event #	8	Not applicable	more
V0613	Secondary Delta V Case Vehicle - Total Delta V	888	Not applicable	more
V0614	Secondarydelta-V Case Vehicle -LONGITUD	8888	—	—
V0615	Secondary delta-V Case Vehicle-Lateral	8888	—	—
V0616	Secondary delta-V Case Vehicle - Energy Dissipated by Crush	8888	—	—
V0617	Secondary Delta-V Case Vehicle-Reconstruction	88	Not applicable	more
V0618	Secondary Delta-V Case Vehicle- Mode	8	Not applicable	more
V0619	Secondary Delta V Contacted Vehicle - Total Delta V	888	Not applicable	more
V0620	Secondary delta-V Contacted Vehicle-LONGITUD	8888	—	—
V0621	Secondary delta-V Contacted Vehicle-Lateral	8888	—	—
V0622	Secondary delta-V Contacted Vehicle - Energy Dissipated By C	8888	—	—
V0623	Primary EBS Case Vehicle-event #	1	Event number 1	more
V0624	Primary EBS Case Vehicle - Total EBS	014 kph	kph	more
V0625	Primary EBS Case Vehicle - LONGITUD	-014	—	—
V0626	Primary EBS Case Vehicle-Lateral	0002	—	—
V0627	Primary EBS Case Vehicle - Energy Dissipated by Crush	0015	—	—

	(kj)			
V0628	Primary EBS Case Vehicle-Reconstruction	22	Reconstructed, moderate confidence level	more
V0629	Primary EBS Case Vehicle-Mode	2	CDC & detailed damage	more
V0630	Primary EBS Contacted Vehicle - Total EBS	999	Unknown	more
V0631	Primary EBS Contacted Vehicle-LONGITUD	9999	—	—
V0632	Primary EBS Contacted Vehicle-Lateral	9999	—	—
V0633	Primary EBS Contact Vehicle - Energy Dissipated by Crush (kj)	9999	—	—
V0634	Secondary EBS Case Vehicle-event #	8	Not applicable	more
V0635	Secondary EBS Case Vehicle - Total EBS	888	Not Applicable	more
V0636	Secondary EBS Case Vehicle -LONGITUD	8888	—	—
V0637	Secondary EBS Case Vehicle-Lateral	8888	—	—
V0638	Secondary EBS Case Vehicle - Energy Dissipated by Crush (kj)	8888	—	—
V0639	Secondary EBS Case Vehicle-Reconstruction	88	Not applicable	more
V0640	Secondary EBS Case Vehicle- Mode	8	Not applicable	more
V0641	Secondary EBS Contacted Vehicle - Total EBS	888	Not Applicable	more
V0642	Secondary EBS Contacted Vehicle-LONGITUD	8888	—	—
V0643	Secondary EBS Contacted Vehicle-Lateral	8888	—	—
V0644	Secondary EBS Contact Vehicle - Energy Dissipated by Crush (8888	—	—
V0645	Specific Event # Case(1)	1	Event number 1	more
V0646	Plane of Impact Case Vehicle (1)	1	Bumper	more
V0647	Direct Damage Length (DDL) - Case Vehicle (1)	155 cm	cm	more

V0648	Direct Damage Maximum Crush - Case Vehicle (1)	009 cm	cm	more
V0649	Direct and Induced Damage Length in CM	148 cm	cm	more
V0650	Field C1 - Case Vehicle (1)	009 cm	cm	more
V0651	Field C2 - Case Vehicle (1)	007 cm	cm	more
V0652	Field C3 - Case Vehicle (1)	006 cm	cm	more
V0653	Field C4 - Case Vehicle (1)	004 cm	cm	more
V0654	Field C5 - Case Vehicle (1)	003 cm	cm	more
V0655	Field C6 - Case Vehicle (1)	004 cm	cm	more
V0656	Direct Damage D Value = The Center of Direct Damage Offset t	+000 cm	Offset (cm)	more
V0657	Specific Event # Case(2)	1	Event number 1	more
V0658	Plane of Impact Case Vehicle (2)	1	Bumper	more
V0659	Direct Damage Length (DDL) - Case Vehicle (2)	155 cm	cm	more
V0660	Direct Damage Maximum Crush - Case Vehicle (2)	009 cm	cm	more
V0661	Direct and Induced Damage Length in CM	148 cm	cm	more
V0662	Field C1 - Case Vehicle (2)	009 cm	cm	more
V0663	Field C2 - Case Vehicle (2)	007 cm	cm	more
V0664	Field C3 - Case Vehicle (2)	006 cm	cm	more
V0665	Field C4 - Case Vehicle (2)	004 cm	cm	more
V0666	Field C5 - Case Vehicle (2)	003 cm	cm	more
V0667	Field C6 - Case Vehicle (2)	004 cm	cm	more
V0668	Direct Damage D Value = The Center of Direct Damage Offset t	+000 cm	cm	more
V0669	Specific Event # Cont(1)	1	Event number 1	more
V0670	Plane of Impact Contacted Vehicle(1)	9	Unknown	more
V0671	Direct Damage Length (DDL) - Contacted Vehicle (1)	999	Unknown	more
V0672	Direct Damage Maximum Crush - Contacted Vehicle (1)	999	Unknown	more
	Field L - Contacted Vehicle			

V0673	(1)	999	Unknown	more
V0674	Field C1 - Contacted Vehicle (1)	999	Unknown	more
V0675	Field C2 - Contacted Vehicle (1)	999	Unknown	more
V0676	Field C3 - Contacted Vehicle (1)	999	Unknown	more
V0677	Field C4 - Contacted Vehicle (1)	999	Unknown	more
V0678	Field C5 - Contacted Vehicle (1)	999	Unknown	more
V0679	Field C6 - Contacted Vehicle (1)	999	Unknown	more
V0680	Direct Damage D Value = The Center of Direct Damage Offset t	+999 cm	offset (cm)	more
V0681	Specific Event # Contacted Vehicle (2)	1	Event number	more
V0682	Plane of Impact Contacted Vehicle(2)	9	Unknown	more
V0683	Direct Damage Length (DDL) - Contacted Vehicle (2)	999	Unknown	more
V0684	Direct Damage Maximum Crush - Contacted Vehicle (2)	999	Unknown	more
V0685	Direct and Induced Damage Length in CM	999	Unknown	more
V0686	Field C1 - Contacted Vehicle (2)	999	Unknown	more
V0687	Field C2 - Contacted Vehicle (2)	999	Unknown	more
V0688	Field C3 - Contacted Vehicle (2)	999	Unknown	more
V0689	Field C4 - Contacted Vehicle (2)	999	Unknown	more
V0690	Field C5 - Contacted Vehicle (2)	999	Unknown	more
V0691	Field C6 - Contacted Vehicle (2)	999	Unknown	more
V0692	Direct Damage D Value = The Center of Direct Damage Offset t	+999 cm	Offset (cm)	more

[Back to Top](#)

Case Vehicle Tires & Rims

Variable Number	Variable Name	Code Value	Code Description	Other Options
V0701	Left Front Wheel Damaged	0	No	more
V0702	Right Front Wheel Damaged	0	No	more
V0703	Right Rear Wheel Damaged	0	No	more
V0704	Left Rear Wheel Damaged	0	No	more
V0705	Left Front Tire Tread Type	4	All Weather	more
V0706	Right Front Tire Tread Type	4	All Weather	more
V0707	Right Rear Tire Tread Type	4	All Weather	more
V0708	Left Rear Tire Tread Type	4	All Weather	more
V0709	Left Front Carcass Construction	3	Radial	more
V0710	Right Front Carcass Construction	3	Radial	more
V0711	Right Rear Carcass Construction	3	Radial	more
V0712	Left Rear Carcass Construction	3	Radial	more
V0713	Left Front Tire Condition Precrash	0	Normal - no pre-crash problems	more
V0714	Right Front Tire Condition Precrash	0	Normal - no pre-crash problems	more
V0715	Right Rear Tire Condition Precrash	0	Normal - no pre-crash problems	more
V0716	Left Rear Tire Condition Precrash	0	Normal - no pre-crash problems	more
V0717	Left Front Tire Condition Postcrash	1	Partially deflated	more
V0718	Right Front Tire Condition Postcrash	0	Normal - no damage to tire	more
V0719	Right Rear Tire Condition Postcrash	1	Partially deflated	more
V0720	Left Rear Tire Condition Postcrash	0	Normal - no damage to tire	more
V0721	Left Front Tire Involvement	0	No	more
V0722	Right Front Tire Involvement	0	No	more
V0723	Right Rear Tire Involvement	0	No	more
V0724	Left Rear Tire Involvement	0	No	more

V0725	Left Front Tire Size	P22560R16	—	—
V0726	Right Front Tire Size	P22560R16	—	—
V0727	Right Rear Tire Size	P22560R16	—	—
V0728	Left Rear Tire Size	P22560R16	—	—
V0729	Left Front Tire Pressure (recorded in psi)	07.0 psi	Actual tire pressure in psi	more
V0730	Right Front Tire Pressure (recorded in psi)	27.5 psi	Actual tire pressure in psi	more
V0731	Right Rear Tire Pressure (recorded in psi)	21.0 psi	Actual tire pressure in psi	more
V0732	Left Rear Tire Pressure (recorded in psi)	30.0 psi	Actual tire pressure in psi	more
V0733	Left Front Tread Depth	08	08/32"	more
V0734	Right Front Tread Depth	08	08/32"	more
V0735	Right Rear Tread Depth	09	09/32"	more
V0736	Left Rear Tread Depth	09	09/32"	more

Case Vehicle Fuel Tank

[Back to Top](#)

Variable Number	Variable Name	Code Value	Code Description	Other Options
V0801	Propulsive Fuel Type	1	Gasoline	more
V0802	Main Tank Location	122	Within frame/centered laterally - within vertical	more
V0803	Main Filler Cap Location	113	Left of frame laterally - above vertically	more
V0804	Main Tank Material	1	Steel	more
V0805	Aux Tank Type	8	Not applicable (not equipped)	more
V0806	Aux Tank Location	888	Not applicable (not equipped)	more
V0807	Aux Filler Cap Location	888	Not applicable (not equipped)	more
V0808	Aux Tank Material	8	Not applicable	more

Case Vehicle Fuel Leakage

[Back to Top](#)

Variable Number	Variable Name	Code Value	Code Description	Other Options
V0901	Fuel Leakage From Crash	0	No	more

Case Vehicle Fire

[Back to Top](#)

--	--	--	--	--

Variable Number	Variable Name	Code Value	Code Description	Other Options
V1001	Fire In Or On Case Vehicle	0	No	more

Case Vehicle Exterior

[Back to Top](#)

Variable Number	Variable Name	Code Value	Code Description	Other Options
V1101	Hood Latch Released	0	No	more
V1102	Hood Latch Damaged	1	Yes	more
V1103	Hood Latch Jammed	1	Yes	more
V1104	Left Hood Hinge Damaged	0	No	more
V1105	Left Hood Hinge Separated	8	Not applicable	more
V1106	Right Hood Hinge Damaged	0	No	more
V1107	Right Hood Hinge Separated	8	Not applicable	more
V1108	Hood Remained On Vehicle	1	Yes	more
V1109	Rear Hood Edge Elevated	1	Yes	more
V1110	Edge Contacted Windshield	0	No	more
V1111	Edge Penetrated Windshield	8	Not applicable	more
V1112	Hood Latch Location	1	Front of Vehicle	more
V1113	Eng/transmissn Mount Separated	0	No	more
V1114	Steering Column Flex Couplng	9	Unknown if equipped	more
V1115	Steering Column Coupling Dam	9	Unknown	more
V1116	Steering Column Coupling Separated	9	Unknown	more
V1117	Eng Comp Telescopng Unit	88	Not currently collected	more
V1118	Compartment Unit's Original/telescoped Length Difference	888	Not currently collected	more
V1119	Left Side Body Mount Separated	0	No	more
V1120	Upper Left A-pillar Sep	0	No	more
V1121	Lower Left A-pillar Sep	0	No	more
V1122	Upper Left B-pillar Sep	0	No	more
V1123	Lower Left B-pillar Sep	0	No	more
V1124	Upper Left C-pillar Sep	0	No	more
V1125	Lower Left C-pillar Sep	0	No	more

V1126	Upper Left D-pillar Sep	8	Not applicable (not equipped)	more
V1127	Lower Left D-pillar Sep	8	Not applicable (not equipped)	more
V1128	Left Front Door Opening Cause	00	Door did not open	more
V1129	Left Rear Door Opening Cause	00	Door did not open	more
V1130	Left Front Door Jammed Closed	0	No	more
V1131	Left Rear Door Jammed Closed	0	No	more
V1132	Van Left Rear Door Type	8	Not applicable (not a van)	more
V1133	Left Front Glazing Availability	2	Closed	more
V1134	Left Rear Glazing Availability	2	Closed	more
V1135	Lr2 Glazing Availability	1	Fixed	more
V1136	Left Front Glazing Damage	0	No damage	more
V1137	Left Rear Glazing Damage	0	No damage	more
V1138	Lr2 Glazing Damage	0	No damage	more
V1139	Rear Door Type	0	No door (includes pickups)	more
V1140	Rear Door Opening Cause	8	Not applicable (no rear door)	more
V1141	Rear Door Jammed Closed	8	Not applicable (no rear door)	more
V1142	Rear Glazng Availability	8	Not Applicable (No Door)	more
V1143	Rear Glazing Damage	8	Not Applicable (No Door)	more
V1144	Luggage Partition Damaged	0	No	more
V1145	Spare Tire Status	8	Not collected	more
V1146	Trailer Hitch Type	0	No hitch	more
V1147	Trailer Type	0	No trailer	more
V1148	Rght Side Body Mount Separated	0	No	more
V1149	Upper Right A-pillar Separated	0	No	more
V1150	Lower Right A-pillar Separated	0	No	more
V1151	Upper Right B-pillar Separated	0	No	more
V1152	Lower Right B-pillar Separated	0	No	more
V1153	Upper Right C-pillar Separated	0	No	more
	Lower Right C-pillar			

V1154	Separated	0	No	more
V1155	Upper Right D-pillar Separated	8	Not applicable (not equipped)	more
V1156	Lower Right D-pillar Separated	8	Not applicable (not equipped)	more
V1157	Right Front Door Opening Cause	00	Door did not open	more
V1158	Right Rear Door Opening Cause	00	Door did not open	more
V1159	Right Front Door Jammed Closed	0	No	more
V1160	Right Rear Door Jammed Closed	0	No	more
V1161	Van Right-rear Door Type	8	Not applicable (not a van)	more
V1162	Right Front Glazing Availability	2	Closed	more
V1163	Right Rear Glazing Availability	2	Closed	more
V1164	Rr2 Glazing Availability	1	Fixed	more
V1165	Right Front Glazing Damage	0	No damage	more
V1166	Right Rear Glazing Damage	0	No damage	more
V1167	Rr2 Glazing Damage	0	No damage	more
V1168	Windshield Cracked	0	No	more
V1169	Windshield Broken	8	Not applicable Click for Windshield Damage figure	more
V1170	Occupant Cracked/Broke Wndshld	8	Not applicable	more
V1171	Bond Separation Extent	0	None	more
V1172	Windshield Code	97	Click for Windshield Mark figure	more
V1173	Did Sun Roof/T-Roof Open	8	Not Applicable	more

Case Vehicle Steering Column/Rim

[Back to Top](#)

Variable Number	Variable Name	Code Value	Code Description	Other Options
V1201	Steering Wheel Rim Damage	0	None	more
V1202	Number of Steering Wheel Spokes	4	4 spokes	more
V1203	Steering Wheel Spoke Damage	0	None	more
V1204	Steering Wheel Hub Damage	1	Occupant contact	more

V1205	Steering Wheel Location of Rim Damage	0	No damage	more
V1206	Aftermarket Add-on Device	0	None	more
V1207	Column Tilt Feature	3	Middle	more
V1208	Column Swing-away Feature	0	Not equipped	more
V1209	Column Telescoping Feature	0	Not equipped	more
V1210	Wheel Energy Absorb Device	8	Not currently collected	more
V1211	Wheel EA Device's original/damage Dimension Difference	888	Not collected	more
V1212	Column Energy Absorb Device	88	Not collected	more
V1213	Col EA Device's Orig/compressed (or Extruded) Length Diff	888	Not collected	more
V1214	Shear Capsule Separation	888	Not collected	more
V1215	Column Vertical Rotation	0	No apparent rotation	more
V1216	Column Lateral Rotation	0	No apparent rotation	more

Case Vehicle Intrusion

[Back to Top](#)

Variable Number	Variable Name	Code Value	Code Description	Other Options
V1301	Was Occupant Compartment Intruded	0	No Click for Intrusion Worksheet figure Click for Intrusion figure	more
V1302	Was Intrusn Catastrophic	8	Not applicable	more
V1303	Intrusion #1	99	Unknown or data not collected	more
V1304	Occupant Space Number(1)	99	Unknown or data not collected	more
V1305	Intrud Component/obj (1)	99	Unknown or data not collected	more
V1306	Associate Event Numb (1)	9	Unknown or data not collected	more
V1307	Maximum Intrusion X Axis	99	Unknown or data not collected	more
V1308	Maximum Intrusion Y Axis	99	Unknown or data not collected	more
V1309	Maximum Intrusion Z Axis	99	Unknown or data not collected	more
V1310	Occupant Number #1 (1)	99	Unknown or data not collected	more
V1311	Injury Number #1 (1)	99	Contact, injury unknown or data not collected	more
V1312	Occupant Number #2 (1)	99	Unknown or data not collected	more
V1313	Injury Number #2 (1)	99	Contact, injury unknown or data not collected	more
V1314	Intrusion Number #2	99	Unknown or data not collected	more

V1315	Occupant Space Number(2)	99	Unknown or data not collected	more
V1316	Intrud Component/obj (2)	99	Unknown or data not collected	more
V1317	Associate Event Numb (2)	9	Unknown or data not collected	more
V1318	Maximum Intrusion X Axis	99	Unknown or data not collected	more
V1319	Maximum Intrusion Y Axis	99	Unknown or data not collected	more
V1320	Maximum Intrusion Z Axis	99	Unknown or data not collected	more
V1321	Occupant Number #1 (2)	99	Unknown or data not collected	more
V1322	Injury Number #1 (2)	99	Contact, injury unknown or data not collected	more
V1323	Occupant Number #2 (2)	99	Unknown or data not collected	more
V1324	Injury Number #2 (2)	99	Contact, injury unknown or data not collected	more
V1325	Intrusion Number #3	99	Unknown or data not collected	more
V1326	Occupant Space Number(3)	99	Unknown or data not collected	more
V1327	Intrud Compnent/obj (3)	99	Unknown or data not collected	more
V1328	Associate Event Numb (3)	9	Unknown or data not collected	more
V1329	Maximum Intrusion X Axis	99	Unknown or data not collected	more
V1330	Maximum Intrusion Y Axis	99	Unknown or data not collected	more
V1331	Maximum Intrusion Z Axis	99	Unknown or data not collected	more
V1332	Occupant Number #1 (3)	99	Unknown or data not collected	more
V1333	Injury Number #1 (3)	99	Contact, injury unknown or data not collected	more
V1334	Occupant Number #2 (3)	99	Unknown or data not collected	more
V1335	Injury Number #2 (3)	99	Contact, injury unknown or data not collected	more
V1336	Intrusion Number #4	99	Unknown or data not collected	more
V1337	Occupant Space Number(4)	99	Unknown or data not collected	more
V1338	Intrud Component/obj (4)	99	Unknown or data not collected	more
V1339	Associate Event Numb (4)	9	Unknown or data not collected	more
V1340	Maximum Intrusion X Axis	99	Unknown or data not collected	more
V1341	Maximum Intrusion Y Axis	99	Unknown or data not collected	more
V1342	Maximum Intrusion Z Axis	99	Unknown or data not collected	more
V1343	Occupant Number #1 (4)	99	Unknown or data not collected	more
V1344	Injury Number #1 (4)	99	Contact, injury unknown or data not collected	more
V1345	Occupant Number #2 (4)	99	Unknown or data not collected	more
V1346	Injury Number #2 (4)	99	Contact, injury unknown or data not collected	more
V1347	Intrusion Number #5	99	Unknown or data not collected	more

V1348	Occupant Space Number(5)	99	Unknown or data not collected	more
V1349	Intrud Component/obj (5)	99	Unknown or data not collected	more
V1350	Associate Event Numb (5)	9	Unknown or data not collected	more
V1351	Maximum Intrusion X Axis	99	Unknown or data not collected	more
V1352	Maximum Intrusion Y Axis	99	Unknown or data not collected	more
V1353	Maximum Intrusion Z Axis	99	Unknown or data not collected	more
V1354	Occupant Number #1 (5)	99	Unknown or data not collected	more
V1355	Injury Number #1 (5)	99	Contact, injury unknown or data not collected	more
V1356	Occupant Number #2 (5)	99	Unknown or data not collected	more
V1357	Injury Number #2 (5)	99	Contact, injury unknown or data not collected	more
V1358	Intrusion Number #6	99	Unknown or data not collected	more
V1359	Occupant Space Number(6)	99	Unknown or data not collected	more
V1360	Intrud Component/obj (6)	99	Unknown or data not collected	more
V1361	Associate Event Numb (6)	9	Unknown or data not collected	more
V1362	Maximum Intrusion X Axis	99	Unknown or data not collected	more
V1363	Maximum Intrusion Y Axis	99	Unknown or data not collected	more
V1364	Maximum Intrusion Z Axis	99	Unknown or data not collected	more
V1365	Occupant Number #1 (6)	99	Unknown or data not collected	more
V1366	Injury Number #1 (6)	99	Contact, injury unknown or data not collected	more
V1367	Occupant Number #2 (6)	99	Unknown or data not collected	more
V1368	Injury Number #2 (6)	99	Contact, injury unknown or data not collected	more
V1369	Intrusion Number #7	99	Unknown or data not collected	more

Driver Airbag

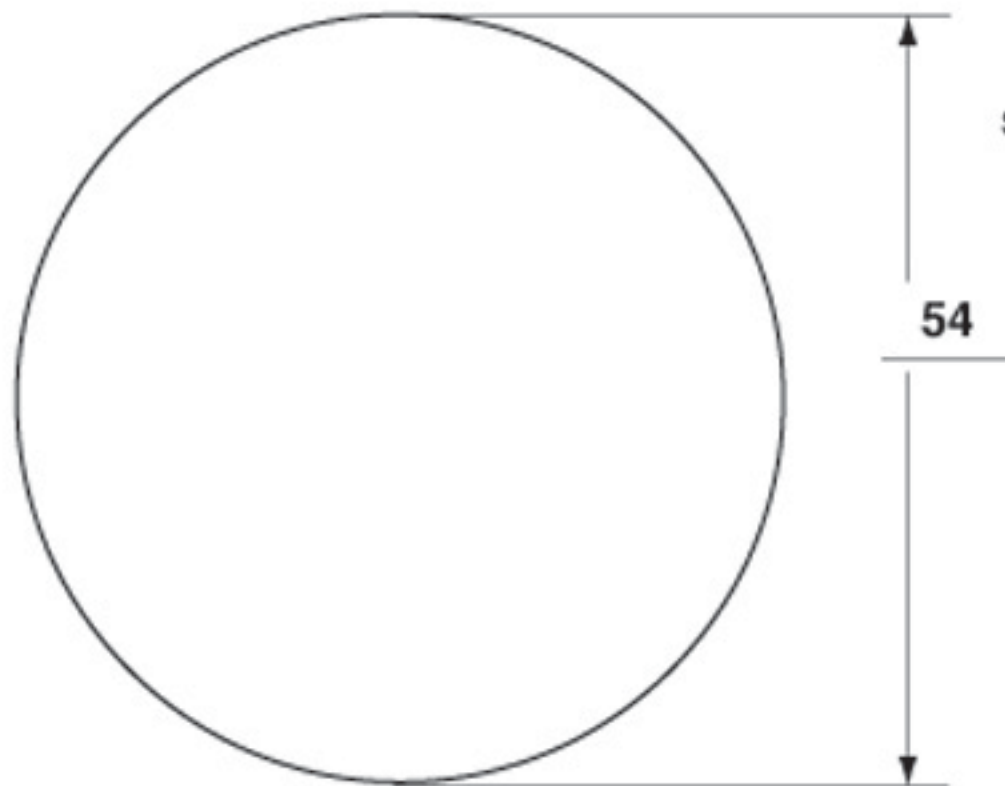

scuffmark

**Driver Airbag Doors
Single Door**

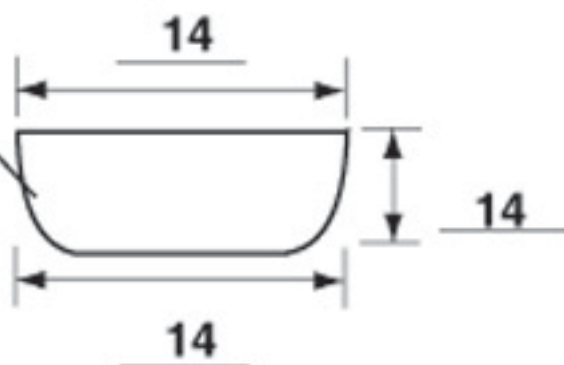

Vents: Y N
if yes, how many: 2

Tethers: Y N
if yes, how many: 2

1 and 11 o'clock on back

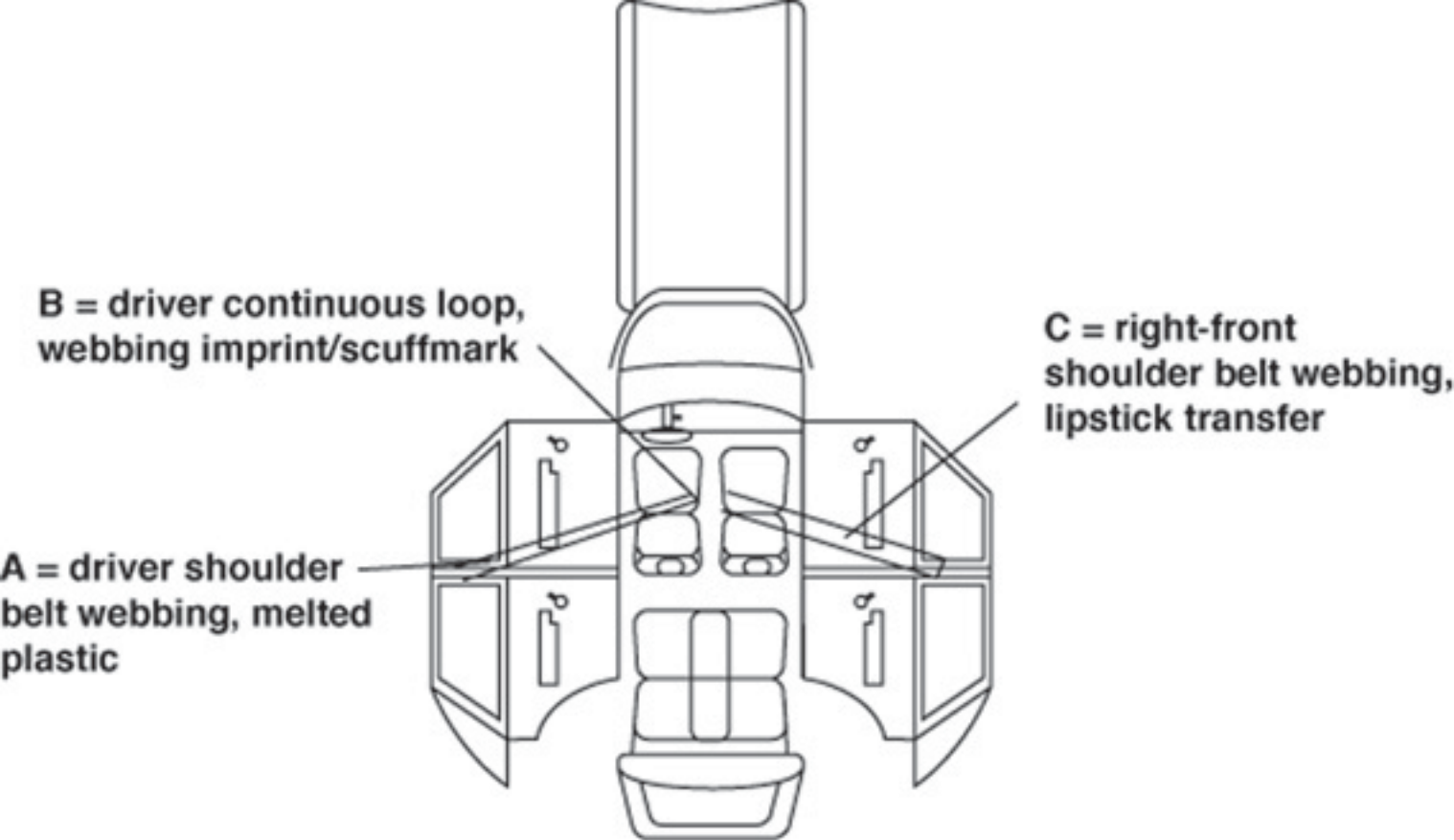

D = steering wheel hub (airbag cover/flap), scuffmark

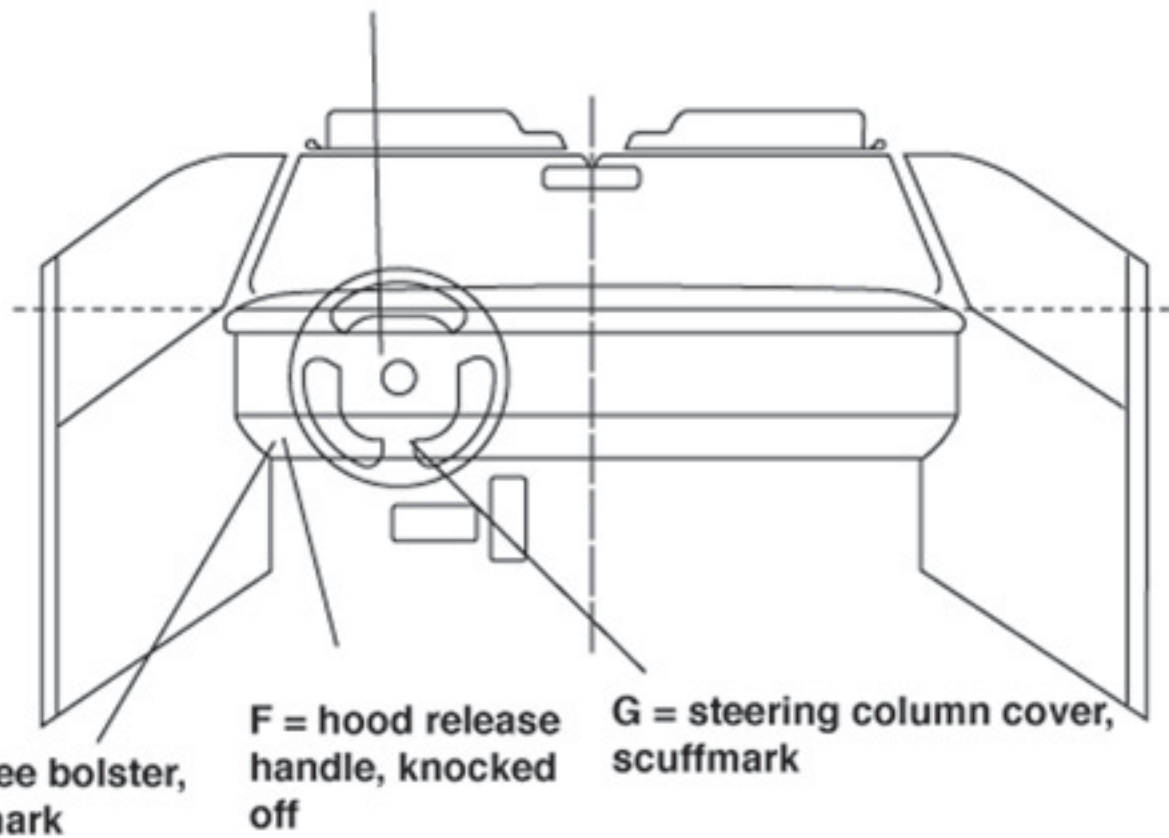

1 = Definitely 2 = Probably 3 = Possible

INTRUSION IT-1

Location of Intrusion	Intruded Component	(All Measurements Are in Centimeters)			Dominant Crush Direction
		Comparison Value	Intruded Value	Intrusion	
None					

OCCUPANT CONTACT WORKSHEET

Contact	Interior Component Contacted	Occupant No. if Known	Body Region if Known	Supporting Physical Evidence	Confidence Level of Contact Point
A	Driver shoulder belt	DR		Melted plastic on webbing	1
B	Driver continuous loop	DR		Webbing imprint/scuffmark	1
C	Right front shoulder belt	RF	Face	Lipstick transfer	1
D	Steering-wheel hub	DR	UX	Scuffmark	2
E	Knee bolster	DR	LX	Scuffmark	1
F	Hood release handle	DR	LX	Knocked off	1
G	Steering column cover	DR		Scuffmark	2



WINDSHIELD MARK ON CASE VEHICLE:



SUNSHADE
SOLAR GREEN
DUPLATE
LAMINATED
SAFETY FLOAT
AS-1 41
2 4
DOT18 M413
DW 1149

MEASUREMENTS IN CENTIMETERS

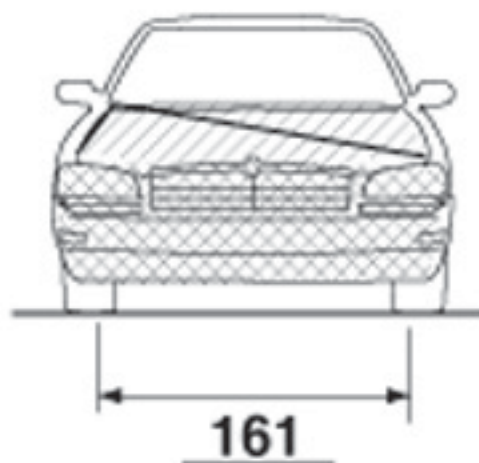

Original
Bumper Height

39

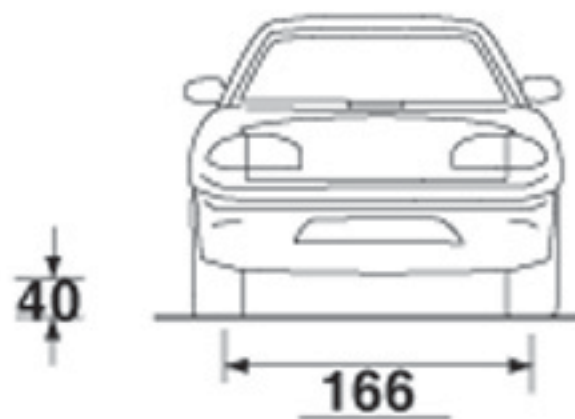

40

166

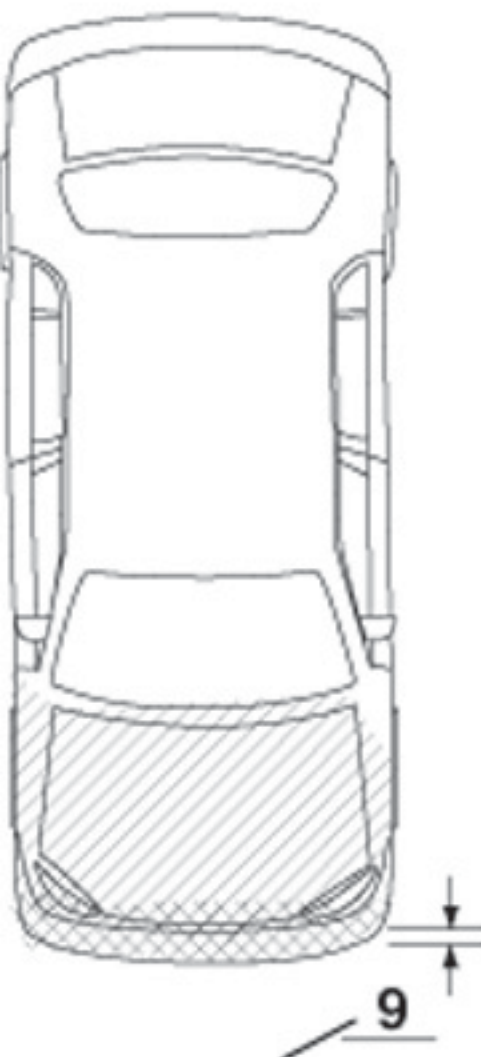

9



161

POST-CRASH

289

Bumper corner
Stringline

92
110

130
139 Bumper corner
Stringline



POST-CRASH

296

Bumper corner
Stringline

130
139

90
103 Bumper corner
Stringline

Max. crush to left
front bumper corner

This vehicle was unavailable for inspection

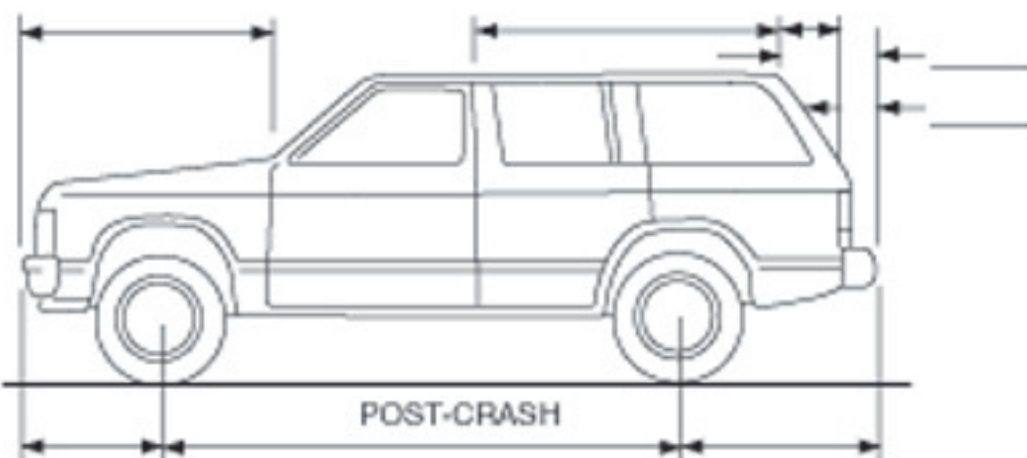
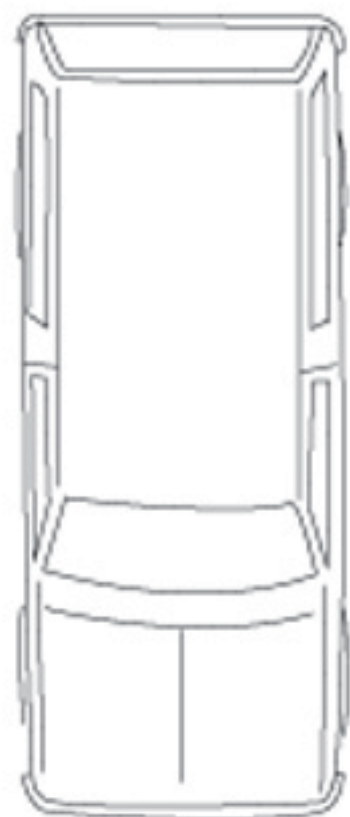
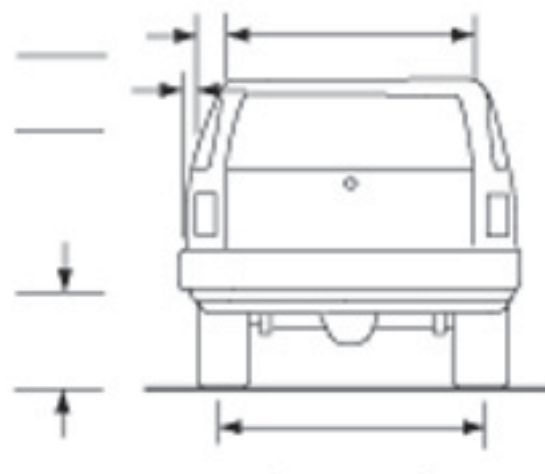
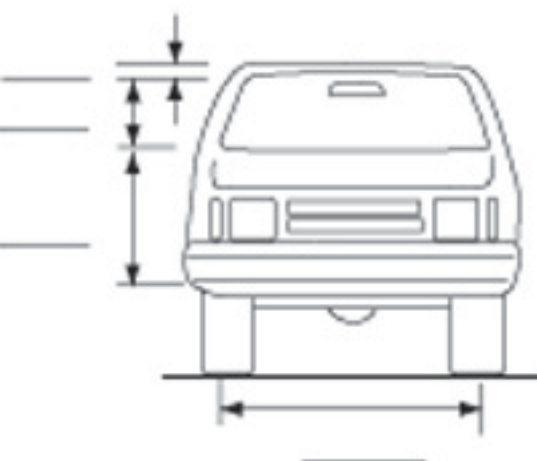

Bumper corner _____
Stringline _____

_____ Bumper corner
_____ Stringline

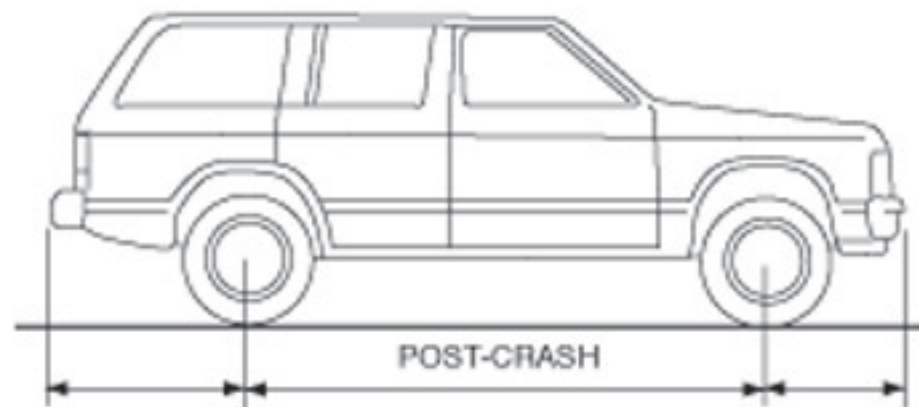

Bumper corner _____
Stringline _____

_____ Bumper corner
_____ Stringline

Passenger Airbag

Passenger Airbag Doors

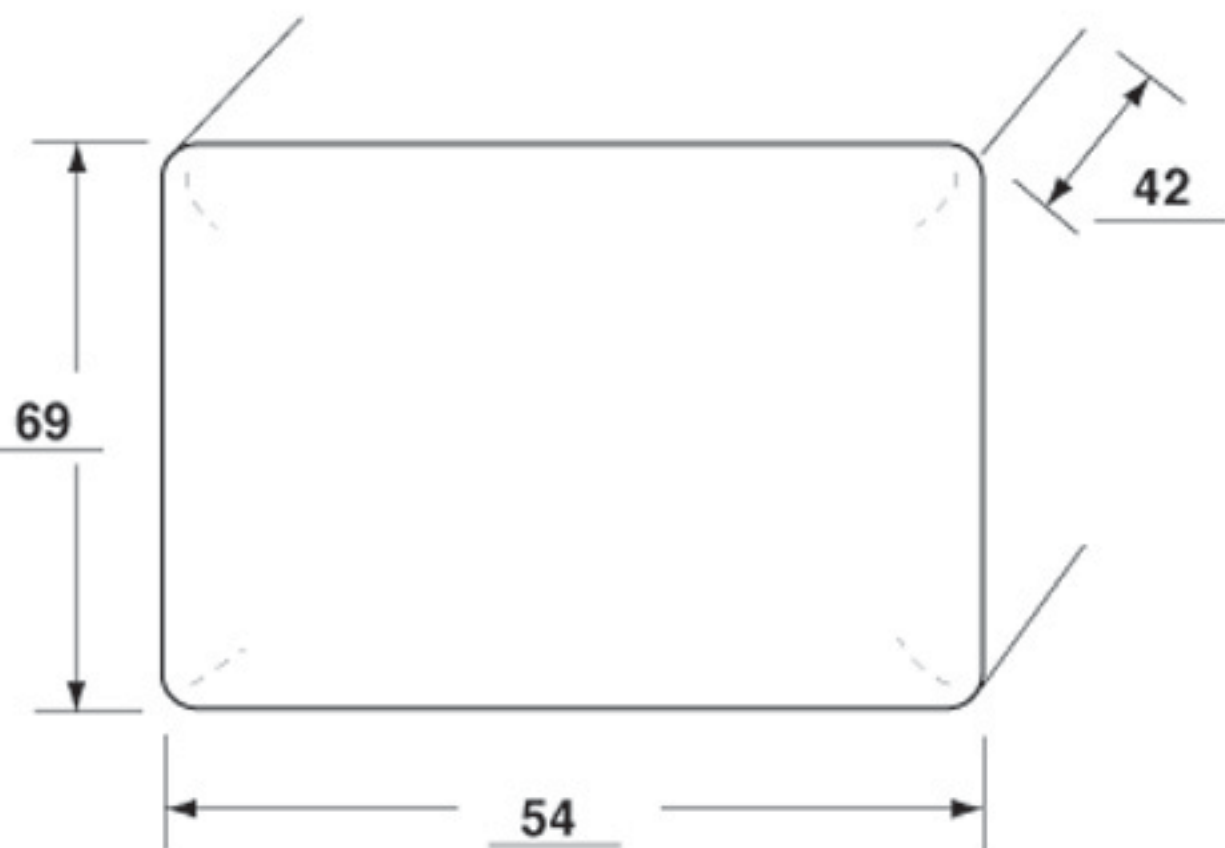

Single Door

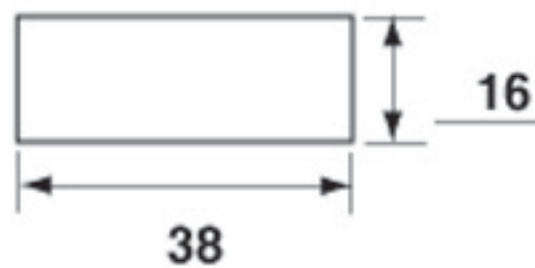

Vents: Y N

If yes, how many: 2

Tethers: Y N

If yes, how many: _____

3 and 9 o'clock on sides













3260091-2



















AIRBAG



























←

AIRBAG



AIRBAG

1 FT & IN

MADE IN USA

P.J.L. APP'D 262 TC

STUD CENTER

ON

OFF



1 2 3 4 5 6 7 8 9 10 11 12 13 14 15 16 17 18
1 2 3 4 5 6 7 8 9 10 11 12 13 14 15 16 17 18
INCHES
P.R. APPROVED LTD
1 2 3 4 5 6 7 8 9 10 11 12 13 14 15 16 17 18
CM









CHIGAN





















