

Case 415 : Narrative

Case Vehicle (A): 1999 Ford	Vehicle (B): 1996 Nissan
Type: Escort, 2-door coupe	Type: Sentra, 4-door sedan
Driver: 76-year-old female	Driver: 23-year-old male
CDC: 11-FYEW-2	CDC: 02-RFEW-3

SITUATION

[1](#) [2](#) [3](#) It was a clear day and the road surface was dry as case vehicle (A) was traveling west at a driver-estimated speed of 45 mph (72 kph) in the outside westbound lane of a five-lane, two-way asphalt road, in a rural area. As case vehicle (A) reached a four-leg intersection with stop signs and a flashing red light for the north/south traffic and the right-of-way for east/west traffic, [4](#) vehicle (B), which had been stopped at the intersection in the northbound lane of the intersecting two-lane asphalt road, [5](#) entered the intersection to continue traveling north. The two vehicles entered the intersection at the same time and the left-front corner of case vehicle (A) struck the right fender of vehicle (B). Both vehicles were towed from the scene.

The police accident report (PAR) indicates B-level injuries for the elderly driver and adult right-front passenger of case vehicle (A), and both were treated at the scene but not transported to the hospital. The PAR indicates B-level injuries for the driver of vehicle (B), who was also treated at the scene but not transported to the hospital.

GENERAL VEHICLE DAMAGE AND ESTIMATED CRASH SEVERITIES

[6](#) Direct damage to the front of case vehicle (A) was moderate. It began at the left-front bumper corner and extended 79-cm across the front bumper, resulting in 52-percent vehicle overlap. [7](#) The maximum crush was 29 cm at the left-front bumper corner.

[8](#) Direct damage to the right side of vehicle (B) was also moderate. It began at the right-front corner and extended 80 cm rearward along the right fender. The maximum lateral crush was 37 cm to the front section of the fender. [9](#) The fender was crushed to the left, the right-front wheel was damaged, and the bumper was shifted to the left. The grille was damaged and both headlight assemblies were broken. There were no changes in the left or right wheelbases.

[10](#) [11](#) [12](#) [13](#) [14](#) [15](#) [16](#) [17](#) [18](#) Using the WinSMASH crash-reconstruction program and c-values measured for both vehicles, the following impact severities were estimated for the front-to-side impact:

		Estimated Velocity Change - kph (mph)		
Vehicle	Variable	Total	Longitudinal	Latitudinal
Case Vehicle (A)	delta V	21 (13)	-19 (-12)	7 (4)
Vehicle (B)	delta V	23 (15)	-8 (-5)	-22 (-14)

DESCRIPTION OF DAMAGE TO CASE VEHICLE (A)

Exterior

[19](#) In the front of case vehicle (A), the left and center portions of the bumper were crushed rearward [20](#) and the bumper cover was separated from the left attachment. [21](#) The left headlight assembly was broken, the grille was shattered, the left-front and center portions of the hood were crushed and pushed rearward and up, and the damaged hood latch had released. [22](#) The right hood hinge was deformed but it was not separated [23](#) and there was no damage to the left hood hinge. [24](#) The right section of the windshield was cracked from internal contact by the deploying dash-mounted airbag [25](#) and there were a few cracks radiating across to the left side of the windshield.

[26](#) On the left side, the front section of the fender had been cut off above the left-front wheel and it was not available for inspection. [27](#) The left-front wheel was pushed rearward, reducing the left wheelbase by 6 cm. [28](#) There was no damage to the A-, B- or C-pillars. [29](#) The driver door was undamaged and operable, and all of the left-side glazing was intact. There was no damage to the left quarter panel or to the left-rear wheel.

[30](#) On the right side, the fender was slightly buckled but there was no damage to the A-, B-, or C-pillars, or to the right-side door or glazing. There was no damage to the right-side wheels and there was no change in the right wheelbase. [31](#) There was no damage to the right quarter panel and [32](#) there was no damage to the rear of the case vehicle.

Interior

[33](#) This vehicle was equipped with steering-wheel and dash-mounted frontal-impact airbags, and both deployed during the frontal impact. [34](#) In the driver area, there was no damage to the steering-wheel airbag [35](#) but there was a faint makeup transfer on the center portion of the airbag fabric. [36](#) There was a light scuffmark on the left side of the upper flap of the steering-wheel airbag module cover. [37](#) There was no damage to the driver section of the roof, to the windshield header, to the sunvisor, or to the interior of the left A-pillar. [38](#) There was no damage to the steering wheel and [39](#) there was no rotation of the steering column. [40](#) The upper and mid portions of the instrument panel were undamaged but there were [41](#) scuffmarks on the left side of the driver knee bolster and on the light-dimmer switch located to the left of the knee bolster. [42](#) There was no damage to the floor or to the foot controls, and [43](#) the interior of the driver door was undamaged.

[44](#) In the center-front area, there was no damage to the roof, to the windshield header, to the headliner, or to the rearview mirror. There were a few cracks radiating across the center of the windshield from the right side, but [45](#) there was no damage to the center dashboard area or to the floor console.

[46](#) In the right-front seating area, there was no damage to the roof, to the windshield header, to the headliner, or to the interior of the right A-pillar. [47](#) There was a dense linear pattern of curved cracks in the center-right section of the windshield from contact by the cover of the deploying dash-mounted airbag. There was [48](#) no damage to the module cover or to [49](#) the airbag, but there was a facial makeup transfer on the lower portion of the fabric. [50](#) There was a scuffmark on the dashboard just above the glove box but there was no damage to the glove box, to the surrounding dashboard area, or [51](#) to the floor.

There were no interior intrusions.

OCCUPANT KINEMATICS AND INJURIES

[52](#) The 168-cm, 82-kg (5-ft 6-in, 180-lb) 76-year-old female driver was using the three-point belt and the steering-wheel airbag deployed. [53](#) [54](#) [55](#) There were no obvious loading marks on the belt webbing, on the D-ring, or on the continuous loop, [56](#) but the belt replacement tab was pulled out, indicating belt use by the driver during the frontal impact. The driver reportedly had adjusted the seat to a mid-track position and was unable to apply the brakes before the crash.

During the frontal impact, she moved forward relative to the vehicle interior, into the belt restraints, [57](#) airbag, and knee bolster. [58](#) She sustained contusions over the left shoulder, to the center of the chest, and to the right breast from loading by the shoulder belt. She sustained cervical strain, probably due to non-contact impact forces, and she sustained an abrasion to the nose from contact by the deploying airbag. She sustained a contusion to the lateral aspect of the left thumb, probably from contact by the airbag module cover, [59](#) as evidenced by a light scuffmark on the left side of the cover. She also sustained contusions across the lower abdomen and to both hips from loading by the lap belt. She sustained contusions to both knees, [60](#) probably from contact with the knee bolster, and she sustained a laceration to the left knee, possibly from contact with [61](#) the dimmer switch or the hood release lever.

[62](#) The 170-cm, 77-kg (5-ft 7-in, 170-lb) 51-year-old female right-front passenger was using the three-point belt and the dash-mounted airbag deployed. [63](#) [64](#) There were no obvious loading marks on the D-ring, on the belt webbing, or on the continuous loop, but the belt replacement tab was pulled out and exposed, indicating belt use by the right-front passenger during the frontal impact.

The right-front passenger reportedly had adjusted the seat to a rear-track position, and during the frontal impact she moved forward relative to the vehicle interior into the belt restraints, airbag, and knee bolster. One of her front teeth was loose after the crash, [65](#) probably from contact by the deploying airbag. [66](#) There was a scuffmark on the dashboard above the glove box indicating possible contact by the right-front passenger, but no knee or leg injuries were reported.

The following tables [67](#) [68](#) and attached drawings summarize the injuries for the two belt-restrained occupants of the case vehicle.

Occupant: Driver	Age: 76 years	Gender: Female		
Restraints: 3-point belt; steering-wheel airbag	Stature: 168 cm (5 ft, 6 in)	Mass: 82 kg (180 lb)		
Injury Description	A.I.S.	Injury Source		
		Definite	Probable	Possible
—	—	—	—	—
Cervical strain	1	—	Non-contact impact forces	—
Abrasion, nose	1	Airbag	—	—
Contusion, left shoulder	1	Shoulder belt	—	—

Contusion, center of chest	1	Shoulder belt	—	—
Contusion, right breast	1	Shoulder belt	—	—
Contusion, lateral aspect of left thumb	1	—	Airbag cover	—
Contusions, across lower abdomen	1	Lap belt	—	—
Contusion, left hip	1	Lap belt	—	—
Contusion, right hip	1	Lap belt	—	—
Contusion, right knee	1	—	Knee bolster	—
Contusion, left knee	1	—	Knee bolster	—
Laceration, left knee	1	—	—	Dimmer switch; hood release lever
Maximum A.I.S. Level	1	—	—	—
Injury Severity Score	2	—	—	—

Occupant: Right front	Age: 51 years	Gender: Female		
Restraints: 3-point belt; dash-mounted airbag	Stature: 170 cm (5 ft, 7 in)	Mass: 77 kg (170 lb)		
Injury Description	A.I.S.	Injury Source		
—	—	Definite	Probable	Possible
Loose front tooth	1	—	Airbag	—
Maximum A.I.S. Level	1	—	—	—
Injury Severity Score	1	—	—	—

CASE NO.: 415

CASE VEHICLE: 1999 Ford

TYPE: Escort, 2-door coupe

OCCUPANT: (Driver) 76-year-old female

STATURE: 168 cm (5 ft, 6 in) MASS: 82 kg (180 lb)

RESTRAINTS: 3-point belt, steering-wheel airbag

SEVERITY: MAIS - 1 ISS - 2

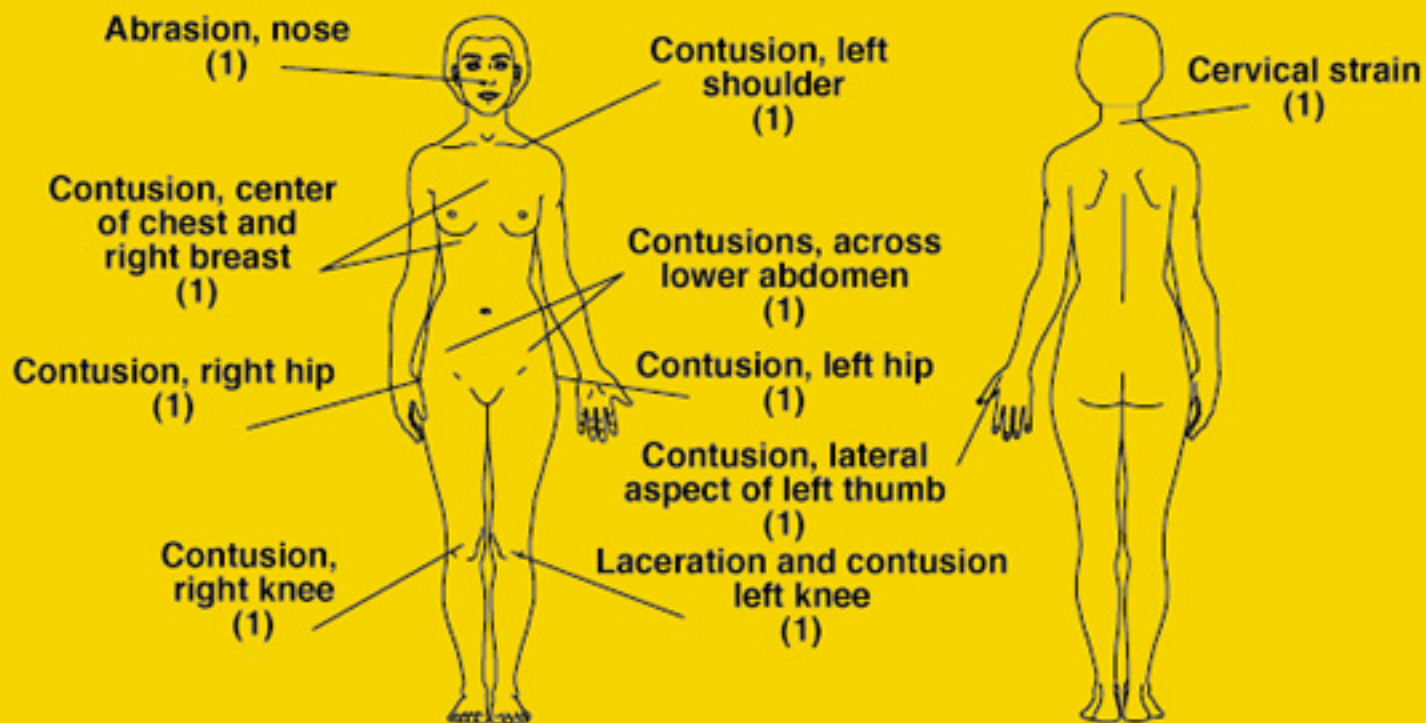

CASE NO.: 415

CASE VEHICLE: 1999 Ford

TYPE: Escort, 2-door coupe

OCCUPANT: (Right front) 51-year-old female

STATURE: 170 cm (5 ft, 7 in) MASS: 77 kg (170 lb)

RESTRAINTS: 3-point belt, dash-mounted airbag

SEVERITY: MAIS - 1 ISS - 1

Loose front tooth
(1)



Case No.: 415
Case Veh. (A): 1999 Ford
Type: Escort, 2-door coupe
Driver: 76-year-old female
Vehicle (B): 1996 Nissan Sentra, 4-door sedan

Weather: Clear
Road Surface: Dry
Road Construction: Asphalt
Light Condition: Daylight

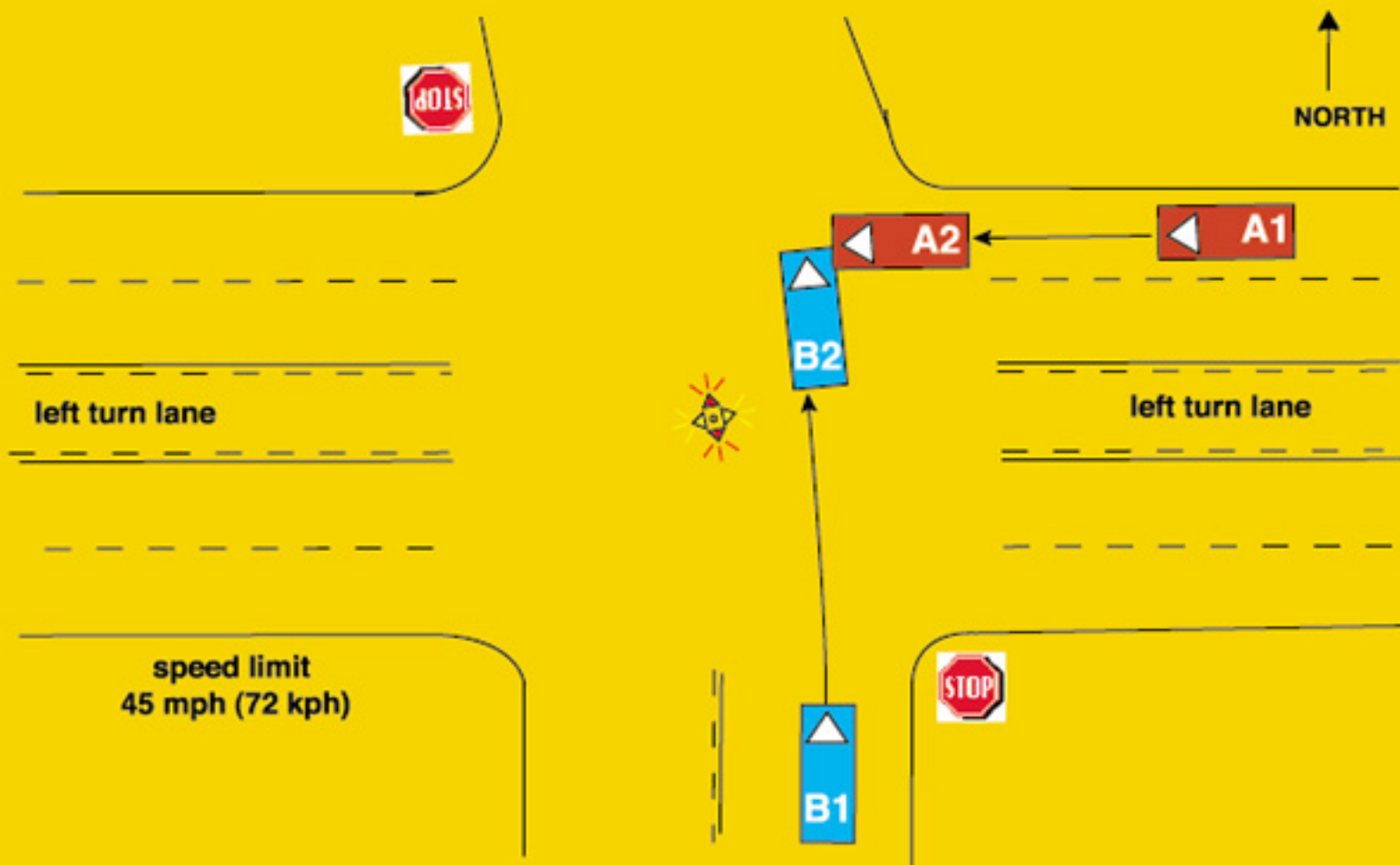

Vehicle Report

Click on Section Name to jump directly to that Section —

- [General Conditions](#)
- [Other Vehicle](#)
- [Case Vehicle General](#)
- [Case Vehicle Damage Description](#)
- [Crash Severity](#)
- [Case Vehicle Tires & Rims](#)
- [Case Vehicle Fuel, Tank, Fire](#)
- [Case Vehicle Exterior](#)
- [Case Vehicle Steering Column/Rim](#)
- [Case Vehicle Intrusion](#)
- [Case Vehicle Airbag\(s\)](#)
- [Case Vehicle Interior](#)
- [Case Vehicle Seats](#)

General Conditions

[Back to Top](#)

Variable Number and Name	Code Value	Code Description	Other Options
V206 — Urban/Rural Area	1	Urban	more
V207 — Limited Access Highway	0	No	more
V208 — Road Total Lanes	4	4 lanes or more	more
V209 — Intersecting Road Total Lanes	2	2 lanes	more
V210 — Road Surface Type	1	Asphalt	more
V211 — Road Defects	0	No	more
V212 — Construction Zone	0	No	more
V213 — Road Alignment Vertical Plane	1	Level	more
V214 — Road Alignment Horizontal Plane	1	Straight	more
V215 — Surface Covering	10	Dry	more
V216 — Visibility Limitation	0	None	more
V217 — Visibility Obstruction	0	None	more
V218 — Speed Limit	4	71-79 km/h .. 45 mph	more
V219 — Precipitation Type	0	None	more
V220 — Precipitation Rate	8	Not applicable	more
V221 — Temperature	9	Unknown	more

V222 — Crosswind	9	Unknown	more
V223 — Light Conditions	1	Daylight	more
V224 — Mechanical Malfunction Mention	0	No	more
V225 — Case Vehicle and Object	0	No	more
V226 — Case Vehicle Rollover	0	No	more
V227 — Case Vehicle Ran Off Roadway	0	No	more
V228 — Moving Case Vehicle/Contacted Moving Vehicle	1	Yes	more
V229 — Case Vehicle/Contacted Stopped Vehicle	0	No	more
V230 — Stopped Case Vehicle/Contactd Vehicle	0	No	more
V231 — Total Vehicles Hit By Case Vehicle	1	1 vehicle	more
V232 — Any Fire in Crash	0	No	more
V233 — Max Police Severity-PAR	2	B - Non-Incapacitating Injury	more
V234 — Driver Alcohol Involvement	0	Had not been drinking	more
V235 — Driver Alcohol BAC	80	Not tested	more
V236 — Driver Impairment Mention	0	No	more
V237 — Driven/Towed From Scene	2	Towed Due to Damage	more

Other Vehicle

[Back to Top](#)

Variable Number and Name	Code Value	Code Description	Other Options
V301 — Other Vehicle VIN	3N1AB41DXTL0	—	—
V302 — Other Vehicle Manufacturer/Body Code	94527	—	—
V303 — Other Vehicle Manufacturer	945	—	—
V304 — Other Vehicle Body Code	27	Compact 100-104.9 in. wb.	more
V305 — Other Vehicle Make/Model	1571	Sentra	more
V306 — Other Vehicle Model Year	1996	—	—
V307 — Other Vehicle Mass	001050 kg	—	—
V308 — Other Vehicle Number	0	No separate report	more
V309 — Other Vehicle Number of Occupants	01	—	—
V310 — Other Vehicle Traveling Speed	995	Just starting up	more

V311 — Highest Police Injury Severity	2	B - Non-Incapacitating Injury	more
V312 — Other Vehicle Type	27	Compact 100-104.9 in. wb.	more
V313 — Other Vehicle Wheelbase (cm)	254 cm	—	—
V314 — Average Track Width	146 cm	—	—
V315 — Overall Length	433 cm	—	—
V316 — Overall Width (OAW)	169 cm	—	—
V317 — Front Overhang (FOH)	087 cm	—	—
V318 — Rear Overhang (ROH)	092 cm	—	—
V319 — Undeformed End Width (UEW)	140 cm	—	—
V320 — Engine Displacement	2.4 l	—	—
V321 — Engine: Number of Cylinders	04	—	—
V322 — Direct Damage Length (DDL)	999	Unknown	more
V323 — Front-End Overlap % (FEO)	99	Missing or Not applicable	more
V324 — Vehicle Overlap % (VOL)	99	Missing or Not applicable	more

Case Vehicle General



[Click for case vehicle figure](#)

[Back to Top](#)

Variable Number and Name	Code Value	Code Description	Other Options
V401 — VIN	3FAKP1130XR1	—	—
V402 — Manufacturer/Body Code	94226	—	—
V403 — Vehicle Manufacturer	942	Ford/Mercury (Mexico)	more
V404 — Vehicle Body Code	26	—	—
V405 — Make/Model Code	0219	Escort	more
V406 — Model Year	1999	—	—
V407 — Vehicle Mass	001126 kg	—	—
V408 — Odometer Reading	045850 miles	—	—
V409 — Number of Occupants	02	—	—
V410 — Traveling Speed	072 kph	—	—
V411 — Body Type	12	2-door sedan or coupe (any upper B-pillar)	more
V412 — Stolen Vehicle	8	Not currently collected	more
V413 — Body Structure	2	Unitized	more
V414 — Transmission Type	1	Automatic	more

V415 — Transmission Lever Location	2	Console	more
V416 — Steering	1	Power	more
V417 — Brakes	1	Power	more
V418 — Brake Type	2	Disc - front wheels	more
V419 — Brake Anti-lock Device	1	Two-wheel	more
V420 — Air Conditioning in Vehicle	8	Not currently collected	more
V421 — Drive Type	2	Front wheel	more
V422 — Dual Rear Wheels	0	No	more
V423 — Original Restraint System Type	3	Airbag	more
V424 — Equipped With Roll Bar	0	No	more
V425 — Roof Type	1	Solid	more
V426 — Wheelbase	250 cm	—	—
V427 — Anti-lacerative Glass	0	None	more
V428 — Average Track Width	144 cm	—	—
V429 — Overall Length	445 cm	—	—
V430 — Overall Width (OAW)	171 cm	—	—
V431 — Front Overhang	096 cm	—	—
V432 — Rear Overhang	099 cm	—	—
V433 — Undeformed End Width (UEW)	150 cm	—	—
V434 — Engine Displacement	2.0 l	—	—
V435 — Engine: Number of Cylinders	04	—	—
V436 — Direct Damage Length (DDL)	079 cm	—	—
V437 — Front End Overlap % (FEO)	53	—	—
V438 — Vehicle Overlap % (VOL)	52	—	—

Case Vehicle

Damage Description

[Back to Top](#)

Variable Number and Name	Code Value	Code Description	Other Options
V501 — Maximum Crush - Front	029 cm	—	—
V502 — Maximum Crush - Right Side	000 cm	No crush (or less than 1 cm.)	more
V503 — Maximum Crush - Rear	000 cm	No crush (or less than 1 cm.)	more
V504 — Maximum Crush - Left Side	000 cm	No crush (or less than 1 cm.)	more

V505 — Maximum Crush - Roof	000 cm	No crush (or less than 1 cm.)	more
V506 — Maximum Crush - Other	000 cm	No crush (or less than 1 cm.)	more
V507 — Are Events In Chronological Order	1	Yes	more
V508 — Event 1 Impact Location	1	On Roadway	more
V509 — Event 1 Impact Configuration	13	FRONT of case veh - SIDE of contacted Vehicle	more
V510 — Event 1 Object/Vehicle Contacted	27	Compact 100-104.9 in. wb.	more
V511 — Event 2 Impact Location	8	No 2nd event	more
V512 — Event 2 Impact Configuration	88	No 2nd event	more
V513 — Event 2 Object/Vehicle Contacted	00	No object/vehicle contacted	more
V514 — Event 3 Impact Location	8	No 3rd event	more
V515 — Event 3 Impact Configuration	88	No 3rd event	more
V516 — Event 3 Object/Vehicle Contacted	00	No object/vehicle contacted	more
V517 — Event 4 Impact Location	8	No 4th event	more
V518 — Event 4 Impact Configuration	88	No 4th event	more
V519 — Event 4 Object/Vehicle Contacted	00	No object/vehicle contacted	more
V520 — Event 5 Impact Location	8	No 5th event	more
V521 — Event 5 Impact Configuration	88	No 5th event	more
V522 — Event 5 Object/Vehicle Contacted	00	No object/vehicle contacted	more
V523 — Event 6 Impact Location	8	No 6th event	more
V524 — Event 6 Impact Configuration	88	No 6th event	more
V525 — Event 6 Object/Vehicle Contacted	00	No object/vehicle contacted	more
V526 — Event 7 Impact On Road	8	No 7th event	more
V527 — Event 7 Impact Configuration	88	No 7th event	more
V528 — Event 7 Object/Vehicle Contacted	00	No object/vehicle contacted	more
V529 — Primary CDC Case Vehicle -event Number	1	Event 1	more
V530 — Primary CDC Case Vehicle	999		

- impact speed		Unknown	more
V531 — Primary CDC Case Vehicle - Estimated By	1	Investigator	more
V532 — Primary CDC Case Vehicle -crush	029	—	—
V533 — Primary CDC Case Vehicle -clock #1	11	11 o'clock	more
V534 — Primary CDC Case Vehicle letter 1 #1	06	F - Front	more
V535 — Primary CDC Case Vehicle letter 2 #1	25	Y - Side or end (F + P or L + C)	more
V536 — Primary CDC Case Vehicle letter 3 #1	05	E - Everything below belt line	more
V537 — Primary CDC Case Vehicle letter 4 #1	23	W - Wide impact area	more
V538 — Primary CDC Case Vehicle Extent #1	02	Extent 2	more
V539 — Primary CDC Case Vehicle -CDC #1	11FYEW2	—	—
V541 — Primary CDC Case Vehicle letter 1 #2	00	Missing Data/Not applicable	more
V542 — Primary CDC Case Vehicle letter 2 #2	00	Missing Data/Not applicable	more
V543 — Primary CDC Case Vehicle letter 3 #2	00	Missing Data/Not applicable	more
V544 — Primary CDC Case Vehicle letter 4 #2	00	Missing Data/Not applicable	more
V545 — Primary CDC Case Vehicle Extent #2	00	Missing Data/Not applicable	more
V546 — Primary CDC Case Vehicle -CDC #2	9800000	—	—
V547 — Primary CDC Contacted Vehicle - Impact Speed	999	Unknown	more
V548 — Primary CDC Contacted Vehicle - Estimated By	1	Investigator	more
V549 — Primary CDC Contacted Vehicle -crush	037	—	—
V550 — Primary CDC Contacted Vehicle -clock #1	02	2 o'clock	more
V551 — Primary CDC Contacted Vehicle letter 1 #1	18	R - Right Side	more
V552 — Primary CDC Contacted Vehicle letter 2 #1	06	F - Side Front (Left or Right) or Front (forward of	more

V553 — Primary CDC Contacted Vehicle letter 3 #1	05	E - Everything below belt line	more
V554 — Primary CDC Contacted Vehicle letter 4 #1	23	W - Wide impact area	more
V555 — Primary CDC Contacted Vehicle Extent #1	03	Extent 3	more
V556 — Primary CDC Contacted Vehicle -CDC #1	02RFEW3	—	—
V558 — Primary CDC Contacted Vehicle letter 1 #2	00	Missing Data/Not applicable	more
V559 — Primary CDC Contacted Vehicle letter 2 #2	00	Missing Data/Not applicable	more
V560 — Primary CDC Contacted Vehicle letter 3 #2	00	Missing Data/Not applicable	more
V561 — Primary CDC Contacted Vehicle letter 4 #2	00	Missing Data/Not applicable	more
V562 — Primary CDC Contacted Vehicle Extent #2	00	Missing Data/Not applicable	more
V563 — Primary CDC Contacted Vehicle -CDC #2	9800000	—	—
V564 — Secondary CDC Case Vehicle - Event No	8	Not applicable	more
V565 — Secondary CDC Case Vehicle - Impact Speed	998	Not Applicable	more
V566 — Secondary CDC Case Vehicle - Estimated By	8	Not applicable (no vehicle/no impact)	more
V567 — Secondary CDC Case Vehicle -crush	998	Not Applicable	more
V568 — Secondary CDC Case Vehicle -clock #1	98	Not Applicable	more
V569 — Secondary CDC Case Vehicle letter 1 #1	00	Missing Data/Not applicable	more
V570 — Secondary CDC Case Vehicle letter 2 #1	00	Missing Data/Not applicable	more
V571 — Secondary CDC Case Vehicle letter 3 #1	00	Missing Data/Not applicable	more
V572 — Secondary CDC Case Vehicle letter 4 #1	00	Missing Data/Not applicable	more
V573 — Secondary CDC Case Vehicle Extent #1	00	Missing Data/Not applicable	more
V574 — Secondary CDC Case Vehicle -CDC #1	9800000	—	—
V576 — Secondary CDC Case	00	Missing Data/Not applicable	more

Vehicle letter 1 #2			
V577 — Secondary CDC Case Vehicle letter 2 #2	00	Missing Data/Not applicable	more
V578 — Secondary CDC Case Vehicle letter 3 #2	00	Missing Data/Not applicable	more
V579 — Secondary CDC Case Vehicle letter 4 #2	00	Missing Data/Not applicable	more
V580 — Secondary CDC Case Vehicle Extent #2	00	Missing Data/Not applicable	more
V581 — Secondary CDC Case Vehicle -CDC #2	9800000	—	—
V582 — Secondary CDC Contacted Vehicle - Impact Speed	998	Not Applicable	more
V583 — Secondary CDC Contacted Vehicle - Estimated By	8	Not applicable (no vehicle/no impact)	more
V584 — Secondary CDC Contacted Vehicle -crush	998	Not Applicable	more
V585 — Secondary CDC Contacted Vehicle -clock #1	98	Not Applicable	more
V586 — Secondary CDC Contacted Vehicle letter 1 #1	00	Missing Data/Not applicable	more
V587 — Secondary CDC Contacted Vehicle letter 2 #1	00	Missing Data/Not applicable	more
V588 — Secondary CDC Contacted Vehicle letter 3 #1	00	Missing Data/Not applicable	more
V589 — Secondary CDC Contacted Vehicle letter 4 #1	00	Missing Data/Not applicable	more
V590 — Secondary CDC Contacted Vehicle Extent #1	00	Missing Data/Not applicable	more
V591 — Secondary CDC Contacted Vehicle -CDC #1	9800000	—	—
V593 — Secondary CDC Contacted Vehicle letter 1 #2	00	Missing Data/Not applicable	more
V594 — Secondary CDC Contacted Vehicle letter 2 #2	00	Missing Data/Not applicable	more
V595 — Secondary CDC Contacted Vehicle letter 3 #2	00	Missing Data/Not applicable	more
V596 — Secondary CDC Contacted Vehicle letter 4 #2	00	Missing Data/Not applicable	more
V597 — Secondary CDC Contacted Vehicle Extent #2	00	Missing Data/Not applicable	more
V598 — Secondary CDC Contacted Vehicle -CDC #2	9800000	—	—

Crash Severity

[Back to Top](#)

Variable Number and Name	Code Value	Code Description	Other Options
V601 — Case Vehicle Primary Impact Number	1	—	—
V602 — Primary Impact Total Delta-V	021 kph	—	—
V603 — Primary Case Vehicle Reconstructed Longitudinal Delta-V	-019 kph	—	—
V604 — Primary Case Vehicle Reconstructed Lateral Delta-V	0007 kph	—	—
V605 — Primary Case Vehicle Reconstructed Crush Energy	0034 kJ	—	—
V606 — Primary Impact Case Vehicle - reconstruction	22	Reconstructed, moderate confidence level	more
V607 — Primary Case Vehicle Reconstruction Mode	2	CDC & detailed damage	more
V608 — Primary Contacted Vehicle Reconstructed	023 kph	—	—

Total Delta-V			
V609 — Primary Contacted Vehicle Reconstructed Longitudinal Delta-V	-008 kph	—	—
V610 — Primary Contacted Vehicle Reconstructed Lateral Delta- V	-022 kph	—	—
V611 — Primary Contacted Vehicle Reconstructed Crush Energy	0034 kJ	—	—
V612 — Case Vehicle Secondary Impact Number	8	—	—
V613 — Secondary Case Vehicle Reconstructed Total Delta-V	888	N/A	more
V614 — Secondary Case Vehicle Reconstructed Longitudinal Delta-V	8888	—	—
V615 — Secondary Case Vehicle Reconstructed Lateral Delta- V	8888	—	—
V616 — Secondary Case Vehicle Reconstructed Crush Energy	8888	—	—

V617 — Secondary Case Vehicle Reconstruction Note	88	—	—
V618 — Secondary Case Vehicle Reconstruction Mode	8	Not applicable	more
V619 — Secondary Contacted Vehicle Reconstructed Total Delta-V	888	N/A	more
V620 — Secondary Contacted Vehicle Reconstructed Longitudinal Delta-V	8888	—	—
V621 — Secondary Contacted Vehicle Reconstructed Lateral Delta- V	8888	—	—
V622 — Secondary Contacted Vehicle Reconstructed Crush Energy	8888	—	—
V623 — Case Vehicle Primary Impact Number	1	—	—
V624 — Primary Case Vehicle Reconstructed Total EBS	021 kph	—	—
V625 — Primary Case	-019 kph		

Vehicle Reconstructed Longitudinal EBS		—	—
V626 — Primary Case Vehicle Reconstructed Lateral EBS	0007 kph	—	—
V627 — Primary Case Vehicle Reconstructed Crush Energy	0034 kJ	—	—
V628 — Primary Case Vehicle Reconstruction Note	22	Reconstructed, moderate confidence level	more
V629 — Primary Case Vehicle Reconstruction Mode	2	CDC & detailed damage	more
V630 — Primary Contacted Vehicle Reconstruction Total EBS	023 kph	—	—
V631 — Primary Contacted Vehicle Reconstruction Longitudinal EBS	-008 kph	—	—
V632 — Primary Contacted Vehicle Reconstruction Lateral EBS	-022 kph	—	—
V633 — Primary Contacted Vehicle Reconstruction	0034 kJ	—	—

Crush Energy			
V634 — Case Vehicle Secondary Impact Number	8	Not applicable	more
V635 — Secondary Case Vehicle Reconstruction Total EBS	888	N/A	more
V636 — Secondary Case Vehicle Reconstruction Longitudinal EBS	8888	—	—
V637 — Secondary Case Vehicle Reconstruction Lateral EBS	8888	—	—
V638 — Secondary Case Vehicle Reconstruction Crush Energy	8888	—	—
V639 — Secondary Case Vehicle Reconstruction Note	88	—	—
V640 — Secondary Case Vehicle Reconstruction Mode	8	Not applicable	more
V641 — Secondary Contacted Vehicle Reconstruction Total EBS	888	N/A	more
V642 — Secondary Contacted Vehicle	8888	—	—

Reconstruction Longitudinal EBS			
V643 — Secondary Contacted Vehicle Reconstruction Lateral EBS	8888	—	—
V644 — Secondary Contacted Vehicle Reconstruction Crush Energy	8888	—	—
V645 — Case Vehicle Reconstructed Impact Number	1	—	—
V646 — Case Vehicle Impact 1 Plane	1	Bumper	more
V647 — Case Vehicle Impact 1 Direct Damage Length [DDL]	079 cm	—	—
V648 — Case Vehicle Impact 1 Max Crush	029 cm	—	—
V649 — Case Vehicle Impact 1 Field-L	127 cm	—	—
V650 — Case Vehicle Impact 1 C1	029 cm	—	—
V651 — Case Vehicle Impact 1 C2	027 cm	—	—
V652 — Case Vehicle Impact 1 C3	023 cm	—	—
V653 — Case	013 cm		

Vehicle Impact 1 C4		—	—
V654 — Case Vehicle Impact 1 C5	000 cm	No Crush	more
V655 — Case Vehicle Impact 1 C6	000 cm	No Crush	more
V656 — Case Vehicle Impact 1 +/- D	-036 cm	—	—
V657 — Case Vehicle Reconstructed Impact Number	2	—	—
V658 — Case Vehicle Impact 2 Plane	8	Not applicable	more
V659 — Case Vehicle Impact 2 Direct Damage Length [DDL]	998	Not applicable	more
V660 — Case Vehicle Impact 2 Max Crush	998	Not applicable	more
V661 — Case Vehicle Impact 2 Field-L	998	Not applicable	more
V662 — Case Vehicle Impact 2 C1	998	Not applicable	more
V663 — Case Vehicle Impact 2 C2	998	Not applicable	more
V664 — Case Vehicle Impact 2 C3	998	Not applicable	more
V665 — Case Vehicle Impact 2 C4	998	Not applicable	more
V666 — Case	998		

Vehicle Impact 2 C5		Not applicable	more
V667 — Case Vehicle Impact 2 C6	998	Not applicable	more
V668 — Case Vehicle Impact 2 +/- D	9998	—	—
V669 — Other Vehicle Reconstructed Impact Number	1	—	—
V670 — Other Vehicle Impact 1 Plane	4	Above sill	more
V671 — Other Vehicle Impact 1 Direct Damage Length [DDL]	080 cm	—	—
V672 — Other Vehicle Impact 1 Max Crush	037 cm	—	—
V673 — Other Vehicle Impact 1 Field-L	109 cm	—	—
V674 — Other Vehicle Impact 1 C1	001 cm	—	—
V675 — Other Vehicle Impact 1 C2	012 cm	—	—
V676 — Other Vehicle Impact 1 C3	026 cm	—	—
V677 — Other Vehicle Impact 1 C4	034 cm	—	—
V678 — Other Vehicle Impact 1 C5	037 cm	—	—
V679 — Other	033 cm		

Vehicle Impact 1 C6		—	—
V680 — Other Vehicle Impact 1 +/- D	0154 cm	—	—
V681 — Other Vehicle Reconstructed Impact Number	2	—	—
V682 — Other Vehicle Impact 2 Plane	8	Not applicable	more
V683 — Other Vehicle Impact 2 Direct Damage Length [DDL]	998	Not applicable	more
V684 — Other Vehicle Impact 2 Max Crush	998	Not applicable	more
V685 — Other Vehicle Impact 2 Field-L	998	Not applicable	more
V686 — Other Vehicle Impact 2 C1	998	Not applicable	more
V687 — Other Vehicle Impact 2 C2	998	Not applicable	more
V688 — Other Vehicle Impact 2 C3	998	Not applicable	more
V689 — Other Vehicle Impact 2 C4	998	Not applicable	more
V690 — Other Vehicle Impact 2 C5	998	Not applicable	more
V691 — Other Vehicle Impact 2 C6	998	Not applicable	more
V692 — Other	9998		

Vehicle Impact 2 +/- D		—	—
---------------------------	--	---	---

Case Vehicle Tires & Rims

[Back to Top](#)

Variable Number and Name	Code Value	Code Description	Other Options
V701 — Left Front Wheel Damaged	0	No	more
V702 — Right Front Wheel Damaged	0	No	more
V703 — Right Rear Wheel Damaged	0	No	more
V704 — Left Rear Wheel Damaged	0	No	more
V705 — Left Front Tire Tread Type	4	All Weather	more
V706 — Right Front Tire Tread Type	4	All Weather	more
V707 — Right Rear Tire Tread Type	4	All Weather	more
V708 — Left Rear Tire Tread Type	4	All Weather	more
V709 — Left Front Carcass Construction	3	Radial	more
V710 — Right Front Carcass Construction	3	Radial	more
V711 — Right Rear Carcass Construction	3	Radial	more
V712 — Left Rear Carcass Construction	3	Radial	more
V717 — Left Front Tire Size	P18565R14	—	—
V718 — Right Front Tire Size	P18565R14	—	—
V719 — Right Rear Tire Size	P18565R14	—	—
V720 — Left Rear Tire Size	P18565R14	—	—

Case Vehicle Fuel, Tank, Fire

[Back to Top](#)

Variable Number and Name	Code Value	Code Description	Other Options
V801 — Propulsive Fuel Type	1	Gasoline	more
V802 — Main Tank Location	322	Within frame/centered laterally - within vertically	more



V803 — Main Filler Cap Location	113	Left of frame laterally - above vertically	more
V804 — Main Tank Material	9	Unknown	more
V805 — Aux Tank Type	8	Not applicable (not equipped)	more
V806 — Aux Tank Location	888	Not applicable (not equipped)	more
V807 — Aux Filler Cap Location	888	Not applicable (not equipped)	more
V808 — Aux Tank Material	8	Not applicable	more
V901 — Fuel Leakage From Crash	0	No	more
V1001 — Fire In Or On Case Vehicle	0	No	more

Case Vehicle Exterior

[Back to Top](#)

Variable Number and Name	Code Value	Code Description	Other Options
V1101 — Hood Latch Released	1	Yes	more
V1102 — Hood Latch Damaged	1	Yes	more
V1103 — Hood Latch Jammed	0	No	more
V1104 — Left Hood Hinge Damaged	0	No	more
V1105 — Left Hood Hinge Separated	8	Not applicable	more
V1106 — Right Hood Hinge Damaged	1	Yes	more
V1107 — Right Hood Hinge Separated	0	No	more
V1108 — Hood Remained On Vehicle	1	Yes	more
V1109 — Rear Hood Edge Elevated	1	Yes	more
V1110 — Edge Contacted Windshield	0	No	more
V1111 — Edge Penetrated Windshield	8	Not applicable	more
V1112 — Hood Latch Location	1	Front of Vehicle	more
V1113 — Eng/Transmissn Mount Separation	0	No	more
V1114 — Steerng Column Flex Coupling	9	Unknown if equipped	more
V1115 — Steerng Column Coupling Damaged	9	Unknown	more
V1116 — Steerng Column Coupling Separated	9	Unknown	more
V1117 — Eng Comp Telescopng Unit	88	Not collected	more
V1118 — Comp Orig/Telescopd Diff	888	Not collected	more
V1119 — Left Side Body Mount Separation	8	Not applicable (unitized)	more

V1120 — Upper Left A-pillar Separation	0	No	more
V1121 — Lower Left A-pillar Separation	0	No	more
V1122 — Upper Left B-pillar Separation	0	No	more
V1123 — Lower Left B-pillar Separation	0	No	more
V1124 — Upper Left C-pillar Separation	0	No	more
V1125 — Lower Left C-pillar Separation	8	Not applicable (not equipped)	more
V1126 — Upper Left D-pillar Separation	8	Not applicable (not equipped)	more
V1127 — Lower Left D-pillar Separation	8	Not applicable (not equipped)	more
V1128 — Left Front Door Opening Cause	0	Door did not open	more
V1129 — Left Rear Door Opening Cause	8	Not applicable (no left rear door)	more
V1130 — Left Front Door Jammed Closed	0	No	more
V1131 — Left Rear Door Jammed Closed	8	Not applicable (no left rear door)	more
V1132 — Rear Door Type	1	Hatchback	more
V1133 — Rear Door Opening Cause	0	Door did not open	more
V1134 — Rear Door Jammed Closed	0	No	more
V1135 — Luggage Partition Damagd	8	Not applicable	more
V1136 — Spare Tire Status	8	Not collected	more
V1137 — Trailer Hitch Type	0	No hitch	more
V1138 — Trailer Type	0	No trailer	more
V1139 — Right Side Body Mount Separation	8	Not applicable (unitized)	more
V1140 — Upper Right A-pillar Separation	0	No	more
V1141 — Lower Right A-pillar Separation	0	No	more
V1142 — Upper Right B-pillar Separation	0	No	more
V1143 — Lower Right B-pillar Separation	0	No	more
V1144 — Upper Right C-pillar	0	No	more

Separation			
V1145 — Lower Right C-pillar Separation	8	Not applicable (not equipped)	more
V1146 — Upper Right D-pillar Separation	8	Not applicable (not equipped)	more
V1147 — Lower Right D-pillar Separation	8	Not applicable (not equipped)	more
V1148 — Right Front Door Opening Cause	00	Door did not open	more
V1149 — Right Rear Door Opening Cause	98	Not applicable (no right rear door)	more
V1150 — Right Front Door Jammed Closed	0	No	more
V1151 — Right Rear Door Jammed Closed	8	Not applicable (no right rear door)	more
V1152 — Van Rear Door Type	8	Not applicable (not a van)	more
V1153 — Windshield Cracked	 Click for windshield damage figure	Yes	more
V1154 — Windshield Broken	0	No	more
V1155 — Windshield Cracked or Broken by Occupant	0	No	more
V1156 — Bond Separation Extent	0	None	more
V1157 — Windshield Code	 Click for windshield code figure	—	—
V1158 — Did Sun/T Roof Open	8	Not Applicable	more

**Case Vehicle
Steering
Column/Rim**

[Back to Top](#)

Variable Number and Name	Code Value	Code Description	Other Options
V1201 — Steering Wheel Rim Damage	0	None	more
V1202 — Number of Steering Wheel Spokes	4	4 spokes	more

V1203 — Steering Wheel Spoke Damage	0	None	more
V1204 — Column Tilt Feature	0	Not equipped	more
V1205 — Column Swing-away Feature	0	Not equipped	more
V1206 — Column Telescoping Feature	0	Not equipped	more
V1207 — Wheel Energy Absorb Device	8	Not collected	more
V1208 — Wheel Ea Orig/Damaged Diff	888	Not collected	more
V1209 — Column Energy Absorb Device	88	Not collected	more
V1210 — Column Ea Orig/Comprss Diff	888	Not collected	more
V1211 — Shear Capsule Separation	888	Not collected	more
V1212 — Column Vertical Rotation	0	No apparent rotation	more
V1213 — Column Lateral Rotation	0	No apparent rotation	more
V1214 — Steering Wheel Hub Damage	0	None	more

Case Vehicle Intrusion

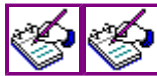

Click for intrusion figures

[Back to Top](#)

Variable Number and Name	Code Value	Code Description	Other Options
V1301 — Occupant Compartment Intrusion	0	No	more
V1302 — Was Intrusion Catastrophic	8	Not applicable	more
V1303 — Intrusion Number 01	00	No Intrusion, None	more
V1304 — Intrusion 01 Occupant Space Number	00	No Intrusion, None	more
V1305 — Intrusion 01 Intruding Object	00	No Intrusion, None	more
V1306 — Intrusion 01 Assoc Event Number	0	No Intrusion, None	more
V1307 — Intrusion 01 Max Intrusion X-axis	00 cm	0 cm or No Intrusion	more
V1308 — Intrusion 01 Max Intrusion Y-axis	00 cm	0 cm or No Intrusion	more
V1309 — Intrusion 01 Max Intrusion Z-axis	00 cm	0 cm or No Intrusion	more

V1310 — Intrusion 01 Occupant Number	00	No contact or no intrusion	more
V1311 — Intrusion 01 Injury Number	00	No injury or no intrusion	more
V1312 — Intrusion 01 Occupant Number	00	No contact or no intrusion	more
V1313 — Intrusion 01 Injury Number	99	Contact, injury unknown or data not collected	more
V1314 — Intrusion Number 02	00	No Intrusion, None	more
V1315 — Intrusion 02 Occupant Space Number	00	No Intrusion, None	more
V1316 — Intrusion 02 Intruding Object	00	No Intrusion, None	more
V1317 — Intrusion 02 Assoc Event Number	0	No Intrusion, None	more
V1318 — Intrusion 02 Max Intrusion X-axis	00 cm	0 cm or No Intrusion	more
V1319 — Intrusion 02 Max Intrusion Y-axis	00 cm	0 cm or No Intrusion	more
V1320 — Intrusion 02 Max Intrusion Z-axis	00 cm	0 cm or No Intrusion	more
V1321 — Intrusion 02 Occupant Number	00	No contact or no intrusion	more
V1322 — Intrusion 02 Injury Number	00	No injury or no intrusion	more
V1323 — Intrusion 02 Occupant Number	00	No contact or no intrusion	more
V1324 — Intrusion 02 Injury Number	99	Contact, injury unknown or data not collected	more
V1325 — Intrusion Number 03	00	No Intrusion, None	more
V1326 — Intrusion 03 Occupant Space Number	00	No Intrusion, None	more
V1327 — Intrusion 03 Intruding Object	00	No Intrusion, None	more
V1328 — Intrusion 03 Assoc Event Number	0	No Intrusion, None	more
V1329 — Intrusion 03 Max Intrusion X-axis	00 cm	0 cm or No Intrusion	more
V1330 — Intrusion 03 Max Intrusion Y-axis	00 cm	0 cm or No Intrusion	more
V1331 — Intrusion 03 Max Intrusion Z-axis	00 cm	0 cm or No Intrusion	more
V1332 — Intrusion 03 Occupant Number	00	No contact or no intrusion	more
V1333 — Intrusion 03 Injury Number	00	No injury or no intrusion	more

V1334 — Intrusion 03 Occupant Number	00	No contact or no intrusion	more
V1335 — Intrusion 03 Injury Number	99	Contact, injury unknown or data not collected	more
V1336 — Intrusion Number 04	00	No Intrusion, None	more
V1337 — Intrusion 04 Occupant Space Number	00	No Intrusion, None	more
V1338 — Intrusion 04 Intruding Object	00	No Intrusion, None	more
V1339 — Intrusion 04 Assoc Event Number	0	No Intrusion, None	more
V1340 — Intrusion 04 Max Intrusion X-axis	00 cm	0 cm or No Intrusion	more
V1341 — Intrusion 04 Max Intrusion Y-axis	00 cm	0 cm or No Intrusion	more
V1342 — Intrusion 04 Max Intrusion Z-axis	00 cm	0 cm or No Intrusion	more
V1343 — Intrusion 04 Occupant Number	00	No contact or no intrusion	more
V1344 — Intrusion 04 Injury Number	00	No injury or no intrusion	more
V1345 — Intrusion 04 Occupant Number	00	No contact or no intrusion	more
V1346 — Intrusion 04 Injury Number	99	Contact, injury unknown or data not collected	more
V1347 — Intrusion Number 05	00	No Intrusion, None	more
V1348 — Intrusion 05 Occupant Space Number	00	No Intrusion, None	more
V1349 — Intrusion 05 Intruding Object	00	No Intrusion, None	more
V1350 — Intrusion 05 Assoc Event Number	0	No Intrusion, None	more
V1351 — Intrusion 05 Max Intrusion X-axis	00 cm	0 cm or No Intrusion	more
V1352 — Intrusion 05 Max Intrusion Y-axis	00 cm	0 cm or No Intrusion	more
V1353 — Intrusion 05 Max Intrusion Z-axis	00 cm	0 cm or No Intrusion	more
V1354 — Intrusion 05 Occupant Number	00	No contact or no intrusion	more
V1355 — Intrusion 05 Injury Number	00	No injury or no intrusion	more
V1356 — Intrusion 05 Occupant Number	00	No contact or no intrusion	more
	99	Contact, injury unknown or data	

V1357 — Intrusion 05 Injury Number		not collected	more
V1358 — Intrusion Number 06	00	No Intrusion, None	more
V1359 — Intrusion 06 Occupant Space Number	00	No Intrusion, None	more
V1360 — Intrusion 06 Intruding Object	00	No Intrusion, None	more
V1361 — Intrusion 06 Assoc Event Number	0	No Intrusion, None	more
V1362 — Intrusion 06 Max Intrusion X-axis	00 cm	0 cm or No Intrusion	more
V1363 — Intrusion 06 Max Intrusion Y-axis	00 cm	0 cm or No Intrusion	more
V1364 — Intrusion 06 Max Intrusion Z-axis	00 cm	0 cm or No Intrusion	more
V1365 — Intrusion 06 Occupant Number	00	No contact or no intrusion	more
V1366 — Intrusion 06 Injury Number	00	No injury or no intrusion	more
V1367 — Intrusion 06 Occupant Number	00	No contact or no intrusion	more
V1368 — Intrusion 06 Injury Number	99	Contact, injury unknown or data not collected	more
V1369 — Intrusion Number 07	00	No Intrusion, None	more
V1370 — Intrusion 07 Occupant Space Number	00	No Intrusion, None	more
V1371 — Intrusion 07 Intruding Object	00	No Intrusion, None	more
V1372 — Intrusion 07 Assoc Event Number	0	No Intrusion, None	more
V1373 — Intrusion 07 Max Intrusion X-axis	00 cm	0 cm or No Intrusion	more
V1374 — Intrusion 07 Max Intrusion Y-axis	00 cm	0 cm or No Intrusion	more
V1375 — Intrusion 07 Max Intrusion Z-axis	00 cm	0 cm or No Intrusion	more
V1376 — Intrusion 07 Occupant Number	00	No contact or no intrusion	more
V1377 — Intrusion 07 Injury Number	00	No injury or no intrusion	more
V1378 — Intrusion 07 Occupant Number	00	No contact or no intrusion	more
V1379 — Intrusion 07 Injury Number	99	Contact, injury unknown or data not collected	more
V1380 — Intrusion Number 08	00	No Intrusion, None	more

V1381 — Intrusion 08 Occupant Space Number	00	No Intrusion, None	more
V1382 — Intrusion 08 Intruding Object	00	No Intrusion, None	more
V1383 — Intrusion 08 Assoc Event Number	0	No Intrusion, None	more
V1384 — Intrusion 08 Max Intrusion X-axis	00 cm	0 cm or No Intrusion	more
V1385 — Intrusion 08 Max Intrusion Y-axis	00 cm	0 cm or No Intrusion	more
V1386 — Intrusion 08 Max Intrusion Z-axis	00 cm	0 cm or No Intrusion	more
V1387 — Intrusion 08 Occupant Number	00	No contact or no intrusion	more
V1388 — Intrusion 08 Injury Number	00	No injury or no intrusion	more
V1389 — Intrusion 08 Occupant Number	00	No contact or no intrusion	more
V1390 — Intrusion 08 Injury Number	99	Contact, injury unknown or data not collected	more
V1391 — Intrusion Number 09	00	No Intrusion, None	more
V1392 — Intrusion 09 Occupant Space Number	00	No Intrusion, None	more
V1393 — Intrusion 09 Intruding Object	00	No Intrusion, None	more
V1394 — Intrusion 09 Assoc Event Number	0	No Intrusion, None	more
V1395 — Intrusion 09 Max Intrusion X-axis	00 cm	0 cm or No Intrusion	more
V1396 — Intrusion 09 Max Intrusion Y-axis	00 cm	0 cm or No Intrusion	more
V1397 — Intrusion 09 Max Intrusion Z-axis	00 cm	0 cm or No Intrusion	more
V1398 — Intrusion 09 Occupant Number	00	No contact or no intrusion	more
V1399 — Intrusion 09 Injury Number	00	No injury or no intrusion	more
V1400 — Intrusion 09 Occupant Number	00	No contact or no intrusion	more
V1401 — Intrusion 09 Injury Number	99	Contact, injury unknown or data not collected	more
V1402 — Intrusion Number 10	00	No Intrusion, None	more
V1403 — Intrusion 10 Occupant Space Number	00	No Intrusion, None	more
V1404 — Intrusion 10 Intruding	00		

Object		No Intrusion, None	more
V1405 — Intrusion 10 Assoc Event Number	0	No Intrusion, None	more
V1406 — Intrusion 10 Max Intrusion X-axis	00 cm	0 cm or No Intrusion	more
V1407 — Intrusion 10 Max Intrusion Y-axis	00 cm	0 cm or No Intrusion	more
V1408 — Intrusion 10 Max Intrusion Z-axis	00 cm	0 cm or No Intrusion	more
V1409 — Intrusion 10 Occupant Number	00	No contact or no intrusion	more
V1410 — Intrusion 10 Injury Number	00	No injury or no intrusion	more
V1411 — Intrusion 10 Occupant Number	00	No contact or no intrusion	more
V1412 — Intrusion 10 Injury Number	99	Contact, injury unknown or data not collected	more
V1413 — Door Intrusion Number 01	88	Not Applicable	more
V1414 — Door Intrusion Number 01 Cause	8	Not applicable	more
V1415 — Door Intrusion Number 02	88	Not Applicable	more
V1416 — Door Intrusion Number 02 Cause	8	Not applicable	more
V1417 — Door Intrusion Number 03	88	Not Applicable	more
V1418 — Door Intrusion Number 03 Cause	8	Not applicable	more
V1419 — Door Intrusion 01 Component	88	Not Applicable	more
V1420 — Door Intrusion 01 Component Damaged 1	8	Not Applicable	more
V1421 — Door Intrusion 01 Component Damaged 2	8	Not Applicable	more
V1422 — Door Intrusion 02 Component	88	Not Applicable	more
V1423 — Door Intrusion 02 Component Damaged 1	8	Not Applicable	more
V1424 — Door Intrusion 02 Component Damaged 2	8	Not Applicable	more
V1425 — Door Intrusion 03 Component	88	Not Applicable	more
V1426 — Door Intrusion 03 Component Damaged 1	8	Not Applicable	more
V1427 — Door Intrusion 03 Component Damaged 2	8	Not Applicable	more

V1428 — Door Intrusion 04 Component	88	Not Applicable	more
V1429 — Door Intrusion 04 Component Damaged 1	8	Not Applicable	more
V1430 — Door Intrusion 04 Component Damaged 2	8	Not Applicable	more

**Case Vehicle
Airbag(s)**



[Click for Driver airbag figure](#)



[Click for Passenger airbag figure](#)

[Back to Top](#)

Variable Number and Name	Code Value	Code Description	Other Options
V1501 — Driver Airbag Equipped	1	Yes	more
V1502 — Driver Airbag Deployed	1	Yes	more
V1503 — Driver Airbag Condition	0	No Damage	more
V1504 — Passenger Airbag Equip	1	Yes	more
V1505 — Passenger Airbag Deployed	1	Yes	more
V1506 — Passenger Airbag Condition	0	No Damage	more
V1507 — Steering Wheel Airbag Tether	1	Yes	more
V1508 — Driver Airbag Marked By Contact	1	Yes	more
V1509 — Passenger Airbag Tether	0	No	more
V1510 — Passenger Airbag Marked By Contact	1	Yes	more

**Case Vehicle
Interior**

[Back to Top](#)

Variable Number and Name	Code Value	Code Description	Other Options
V1601 — Left Front Door Damaged	0	No	more
V1602 — Right Front Door Damaged	0	No	more
V1603 — Left Front Hardware Damaged	0	No	more
V1604 — Right Front Hardware Damaged	0	No	more
V1605 — Left Front Armrest Damaged	0	No	more

V1606 — Right Front Armrest Damaged	0	No	more
V1607 — Left Front Glass Damaged	0	No	more
V1608 — Right Front Glass Damaged	0	No	more
V1609 — Left Rear Door Area Damaged	0	No	more
V1610 — Right Rear Door Area Damaged	0	No	more
V1611 — Left Rear Hardware Damaged	0	No	more
V1612 — Right Rear Hardware Damaged	0	No	more
V1613 — Left Rear Armrest Damaged	0	No	more
V1614 — Right Rear Armrest Damaged	0	No	more
V1615 — Left Rear Glass Damaged	0	No	more
V1616 — Right Rear Glass Damaged	0	No	more
V1617 — Left Roof Side Rail Damaged	0	No	more
V1618 — Right Roof Side Rail Damaged	0	No	more
V1619 — Left B-pillar Damaged	0	No	more
V1620 — Right B-pillar Damaged	0	No	more
V1621 — Left C-pillar Damaged	0	No	more
V1622 — Right C-pillar Damaged	0	No	more
V1623 — Left D-pillar Damaged	8	Not applicable	more
V1624 — Right D-pillar Damaged	8	Not applicable	more
V1625 — Left Headlining Damaged	0	No	more
V1626 — Right Headlining Damaged	0	No	more
V1627 — Left Roof Structure Damaged	0	No	more
V1628 — Right Roof Structure Damaged	0	No	more
V1629 — Left T/Sun Roof Damaged	8	Not applicable	more
V1630 — Right T/Sun Roof Damaged	8	Not applicable	more
V1631 — Other Left Side Item Damaged	8	Not applicable	more
V1632 — Other Right Side Item Damaged	8	Not applicable	more
V1633 — Foot Controls Damaged	0	No	more

V1634 — Ignition Key Damaged	0	No	more
V1635 — Rear View Mirror Damaged	0	No	more
V1636 — Sunvisor/Fitting Damaged	0	No	more
V1637 — Windshield Molding Damaged	0	No	more
V1638 — Left A-pillar Damaged	0	No	more
V1639 — Right A-pillar Damaged	0	No	more
V1640 — Center Console Damaged	0	No	more
V1641 — Transmission Lever Damaged	0	No	more
V1642 — Horn/Spoke Shroud Damaged	0	No	more
V1643 — Upper Panel Damaged	0	No	more
V1644 — Mid Panel Damaged	0	No	more
V1645 — Lower Panel Damaged	3	No, occupant contact	more
V1646 — Ashtray Damaged	0	No	more
V1647 — Control Knob/Lever Damaged	0	No	more
V1648 — Glove Compartment Area Damaged	0	No	more
V1649 — Instruments Damaged	0	No	more
V1650 — Park Brake Release Damaged	0	No	more
V1651 — Park Brake Pedal Damaged	0	No	more
V1652 — A/C Or Upper Vent Damaged	0	No	more
V1653 — Heater Or A/C Duct Damaged	0	No	more
V1654 — Radio Damaged	0	No	more
V1655 — Other Item Damaged	8	Not applicable	more
V1656 — Rear Window Damaged	0	No	more
V1657 — Rear Window Header Damaged	0	No	more
V1658 — Vertical Console Damaged	0	No	more
V1659 — Roof Console Damaged	8	Not applicable	more

Case Vehicle Seats

[Back to Top](#)

Variable Number and Name	Code Value	Code Description	Other Options

V1701 — Driver Front Seat Type	05	Bucket	more
V1702 — Passenger Front Seat Type	05	Bucket	more
V1703 — Driver Seat Mount Type	1	Standard	more
V1704 — Passenger Seat Mount Type	1	Standard	more
V1705 — Driver Swivel Mechanism Equipped	0	No	more
V1706 — Passenger Swivel Mechanism Equipped	0	No	more
V1707 — Driver Seat Original Equipment	1	Yes	more
V1708 — Passenger Seat Original Equipment	1	Yes	more
V1709 — Driver Seat/Rear Occupant Contact	8	Not applicable	more
V1710 — Passenger Seat/Rear Occupant Contact	8	Not applicable	more
V1711 — Driver Seat Damage	0	None	more
V1712 — Passenger Seat Damage	0	None	more
V1713 — Center Front Armrest Damaged	8	Not applicable (no center armrest)	more
V1714 — Driver Seat Rotation	0	None apparent	more
V1715 — Passenger Seat Rotation	0	None apparent	more
V1716 — Driver Seat-back Type	1	Forward folding	more
V1717 — Passenger Seat-back Type	1	Forward folding	more
V1718 — Driver Seat-back Lock Type	1	Manual	more
V1719 — Passenger Seat-back Lock Type	1	Manual	more
V1720 — Driver Seat-back Lock Held	1	Yes	more
V1721 — Passenger Seat-back Lock Held	1	Yes	more
V1722 — Driver Recliner Mechanism Held	1	Yes	more
V1723 — Passenger Recliner Mechanism Held	1	Yes	more
V1724 — Driver Head Restraint Type	1	Adjustable	more
V1725 — Passenger Head Restraint Type	1	Adjustable	more

V1726 — Driver Head Rest Removed	0	No	more
V1727 — Passenger Head Rest Removed	0	No	more
V1728 — Driver Head Rest Adjustment	1	Up	more
V1729 — Passenger Head Rest Adjustment	1	Up	more
V1730 — Driver Head Rest Damage	0	None	more
V1731 — Passenger Head Rest Damage	0	None	more
V1732 — Driver Seat Adjustment Type	1	Manual	more
V1733 — Passenger Seat Adjustment Type	1	Manual	more
V1734 — Driver Seat Adjustment Provided	1	2-way	more
V1735 — Passenger Seat Adjustment Provided	1	2-way	more
V1736 — Driver Seat Adjuster Damage	0	None	more
V1737 — Passenger Seat Adjuster Damage	0	None	more
V1738 — Driver Seat Adjuster Separation	8	Not applicable	more
V1739 — Passenger Seat Adjuster Separation	8	Not applicable	more
V1740 — Driver Seat Pre-crash Position	2	Middle	more
V1741 — Passenger Seat Pre-crash Position	3	Rearward	more
V1742 — Left Rear Seat Type	6	Luggage area access panel	more
V1743 — Right Rear Seat Type	6	Luggage area access panel	more
V1744 — Left Rear Seat Damaged	0	None	more
V1745 — Right Rear Seat Damaged	0	None	more
V1746 — Center Rear Armrest Damaged	8	Not applicable (No Center Armrest)	more
V1747 — Left Rear Seat-back Left Lock Equipped	1	Yes	more
V1748 — Right Rear Seat-back Left Lock Equipped	0	No	more
V1749 — Left Rear Seat-back Left Lock Held	1	Yes	more

V1750 — Right Rear Seat-back Left Lock Held	8	Not applicable	more
V1751 — Left Rear Seat-back Right Lock Equipped	0	No	more
V1752 — Right Rear Seat-back Right Lock Equipped	1	Yes	more
V1753 — Left Rear Seat-back Right Lock Held	8	Not applicable	more
V1754 — Right Rear Seat-back Right Lock Held	1	Yes	more
V1755 — Left 3rd Seat Equipped	0	No	more
V1756 — Right 3rd Seat Equipped	0	No	more
V1757 — Left 3rd Seat Backrest Damaged	8	Not applicable	more
V1758 — Right 3rd Seat Backrest Damaged	8	Not applicable	more
V1759 — Left 3rd Seat Cushion Damaged	8	Not applicable	more
V1760 — Right 3rd Seat Cushion Damaged	8	Not applicable	more
V1761 — Rear Head Restraints	0	Not Equipped (or removed)	more

Driver Airbag

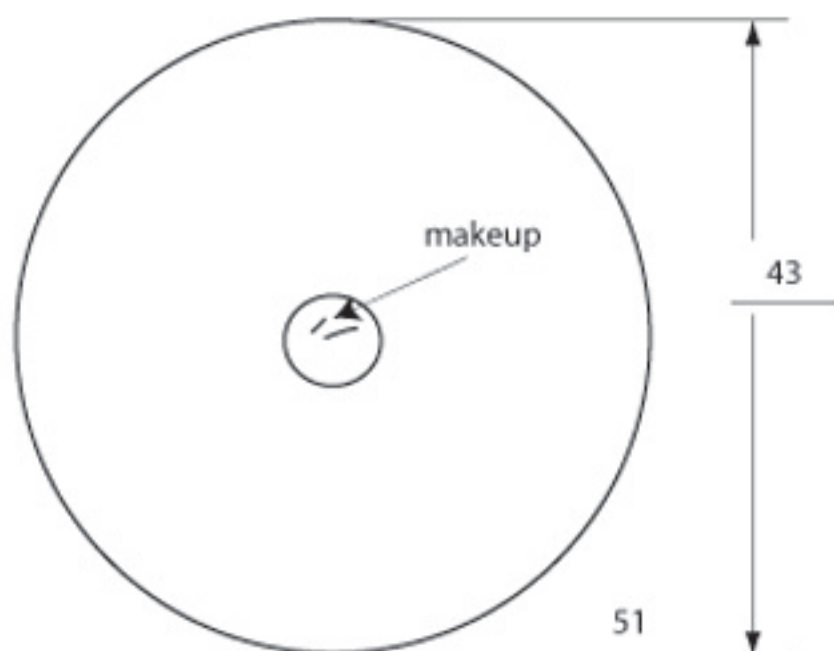

Vents: Y N
if yes, how many: 2

Tethers: Y N
if yes, how many: 2

Driver Airbag Doors

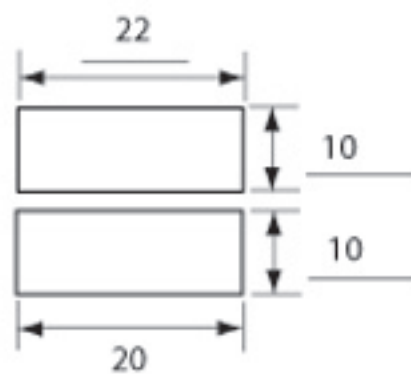

H-Pattern

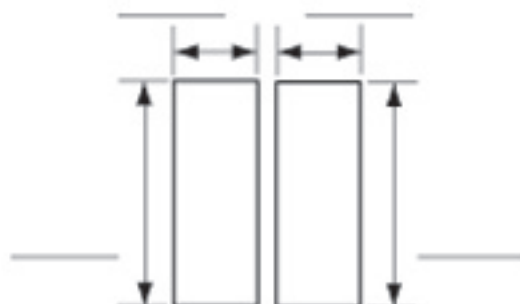

I-Pattern

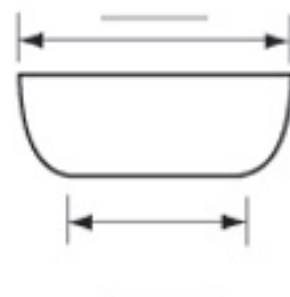

Single Door

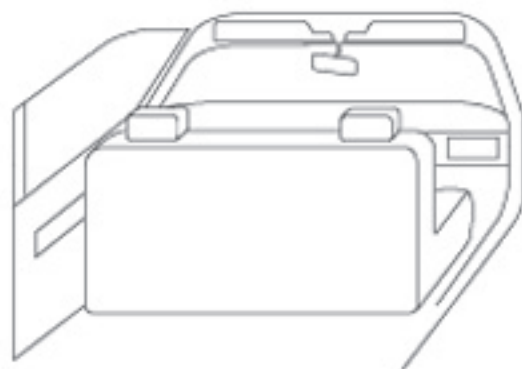
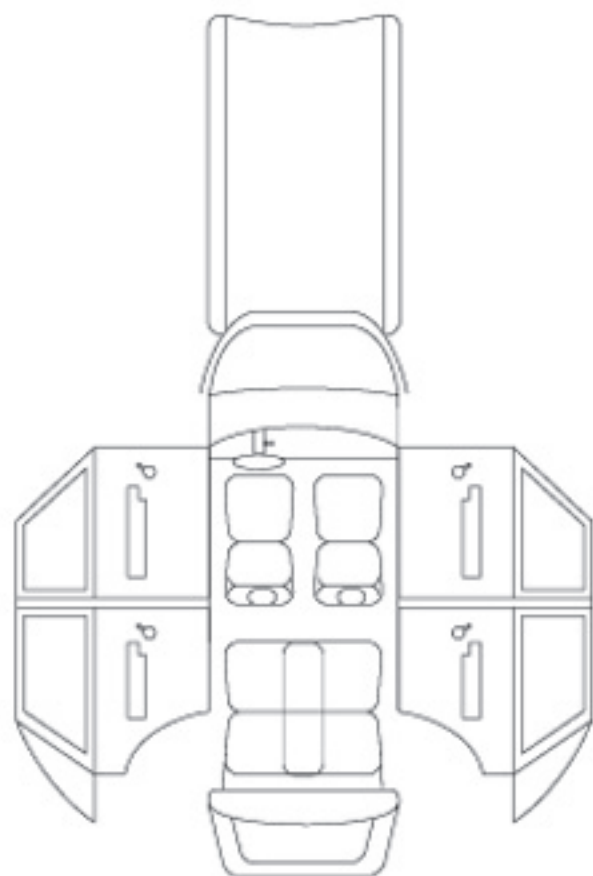

Dr belt: loading mark on webbing,
loading mark on d-ring,
replacement tab pulled out

RF belt: replacement tab pulled out

- A: steering-wheel airbag, facial makeup on fabric
- B: steering-wheel airbag flap, scuff
- C: dimmer light switch on knee bolster, scuff
- D: knee bolster - scuff on left
- E: IP above glove box, scuff
- F: dash-mounted airbag, facial makeup

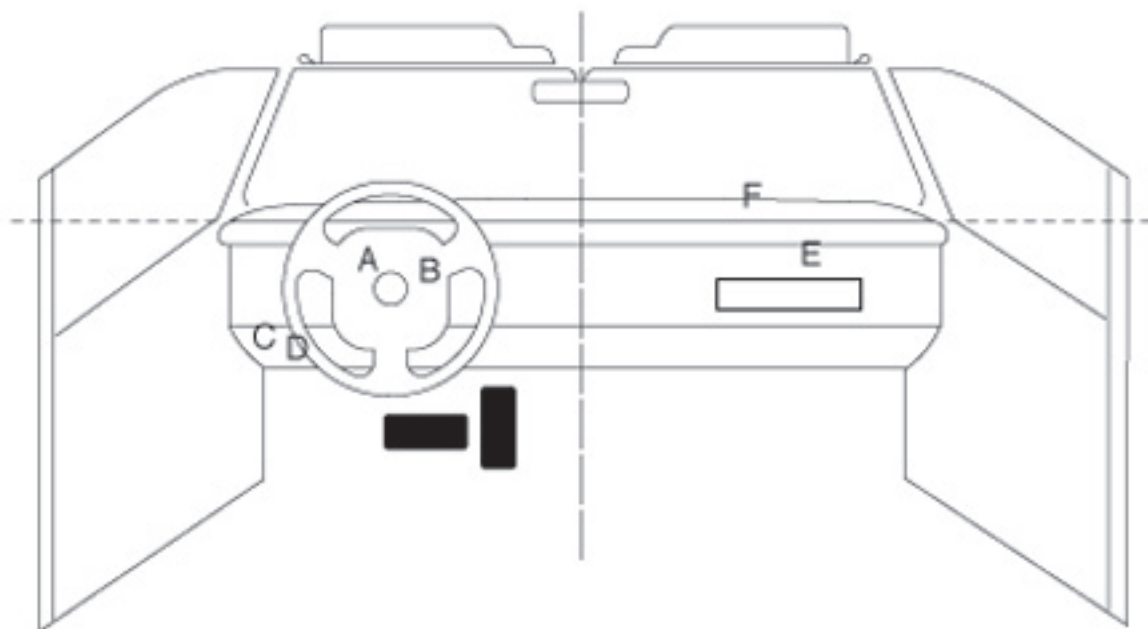

1 = Definitely 2 = Probably 3 = Possible

INTRUSION IT-1

Location of Intrusion	Intruded Component	(All Measurements Are in Centimeters)			Dominant Crush Direction
		Comparison Value	Intruded Value	Intrusion	
none		-	=		
		-	=		
		-	=		
		-	=		
		-	=		
		-	=		
		-	=		
		-	=		
		-	=		
		-	=		
		-	=		
		-	=		
		-	=		
		-	=		

OCCUPANT CONTACT WORKSHEET

Contact	Interior Component Contacted	Occupant No. if Known	Body Region if Known	Supporting Physical Evidence	Confidence Level of Contact Point
A	Steering-wheel airbag	1	Face	Facial makeup	1
B	Steering-wheel airbag flap	1	Hand	Scuff	1
C	Dimmer switch on bolster	1	Left knee	Scuff	1
D	Knee bolster	1	Left knee	Scuff on left	1
E	IP above glove box	2	Knee	Scuff	1
F	Dash-mounted airbag	2	Face	Facial makeup	1

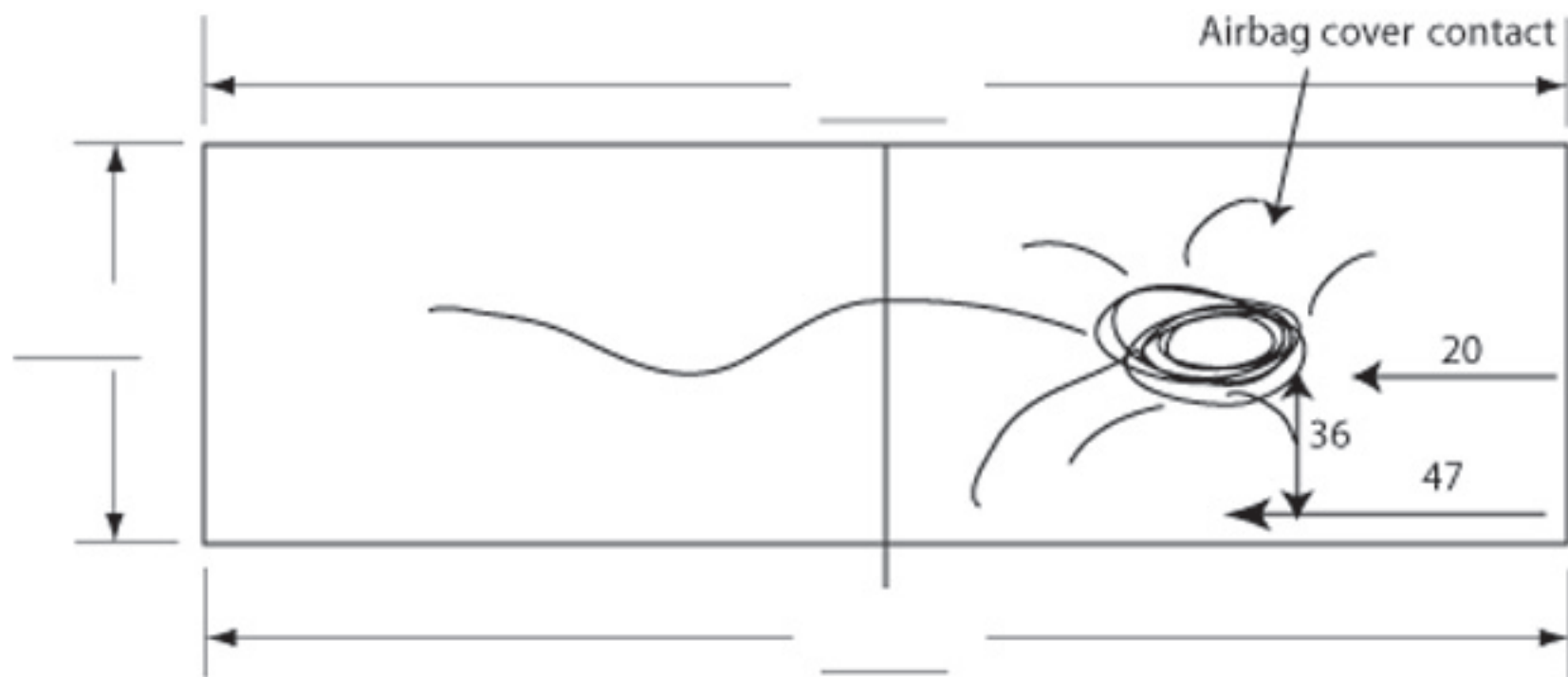

WINDSHIELD MARK ON CASE VEHICLE:

SOLAR TINT™

V



LAMINATED®

AS1

DOT - 287 VF-M562

8 A C

DW-1300

MEASUREMENTS IN CENTIMETERS

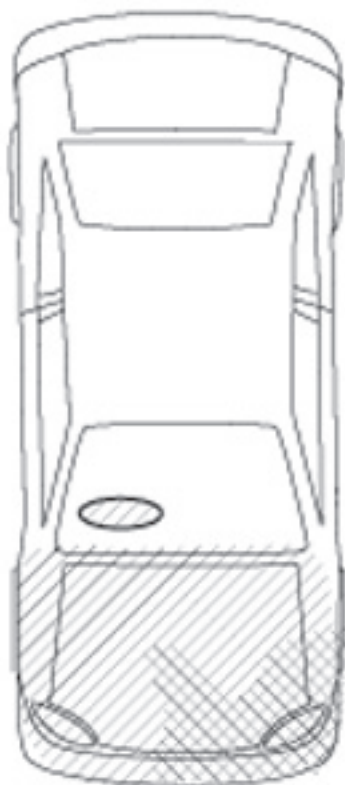
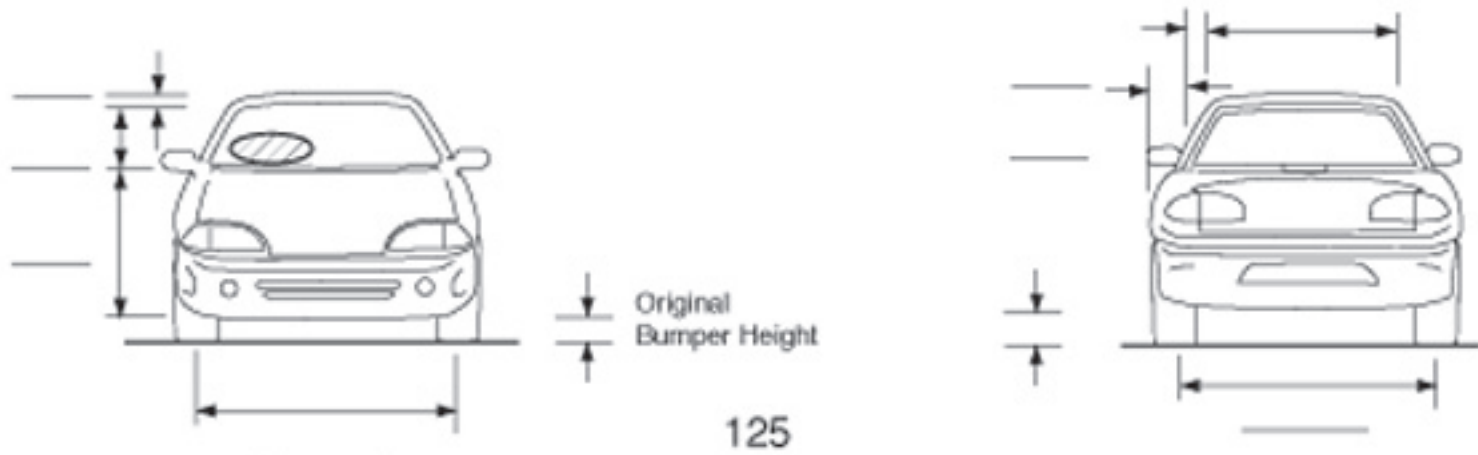

79 cm direct damage
29 cm max crush

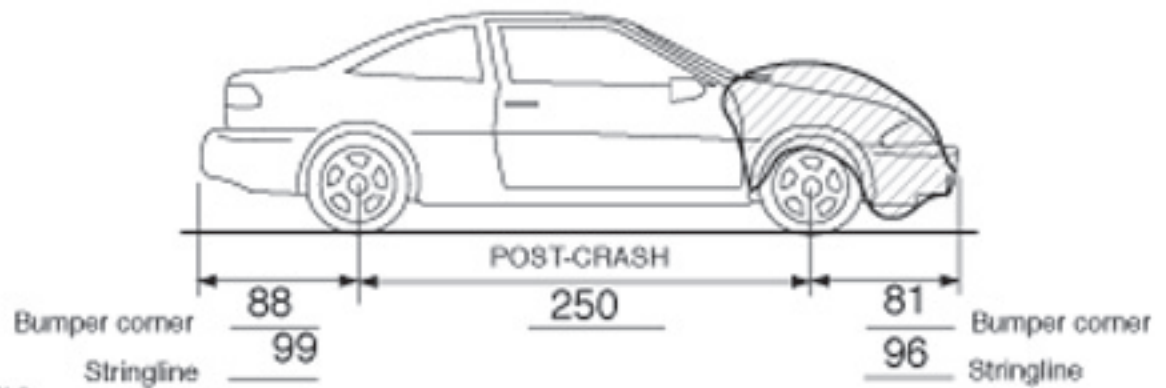
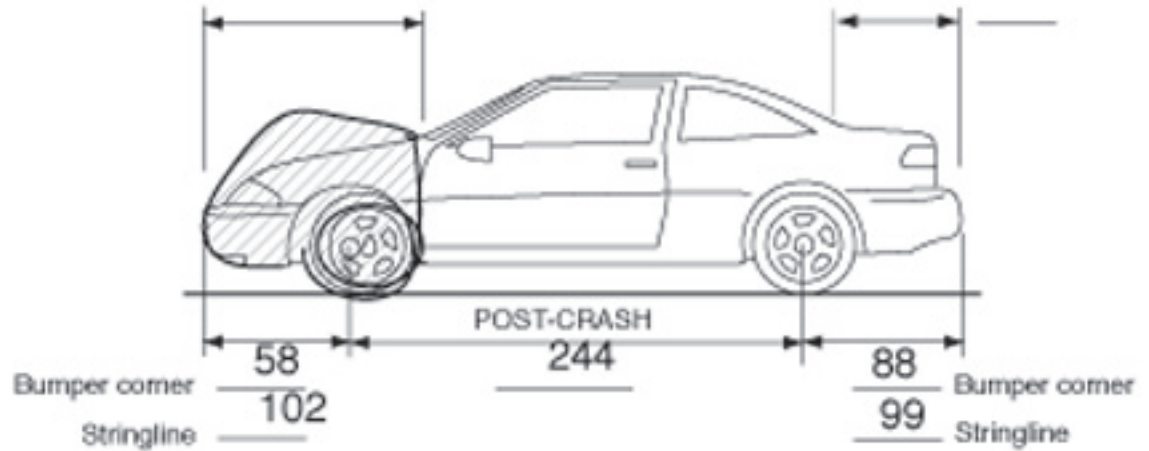

MEASUREMENTS IN CENTIMETERS

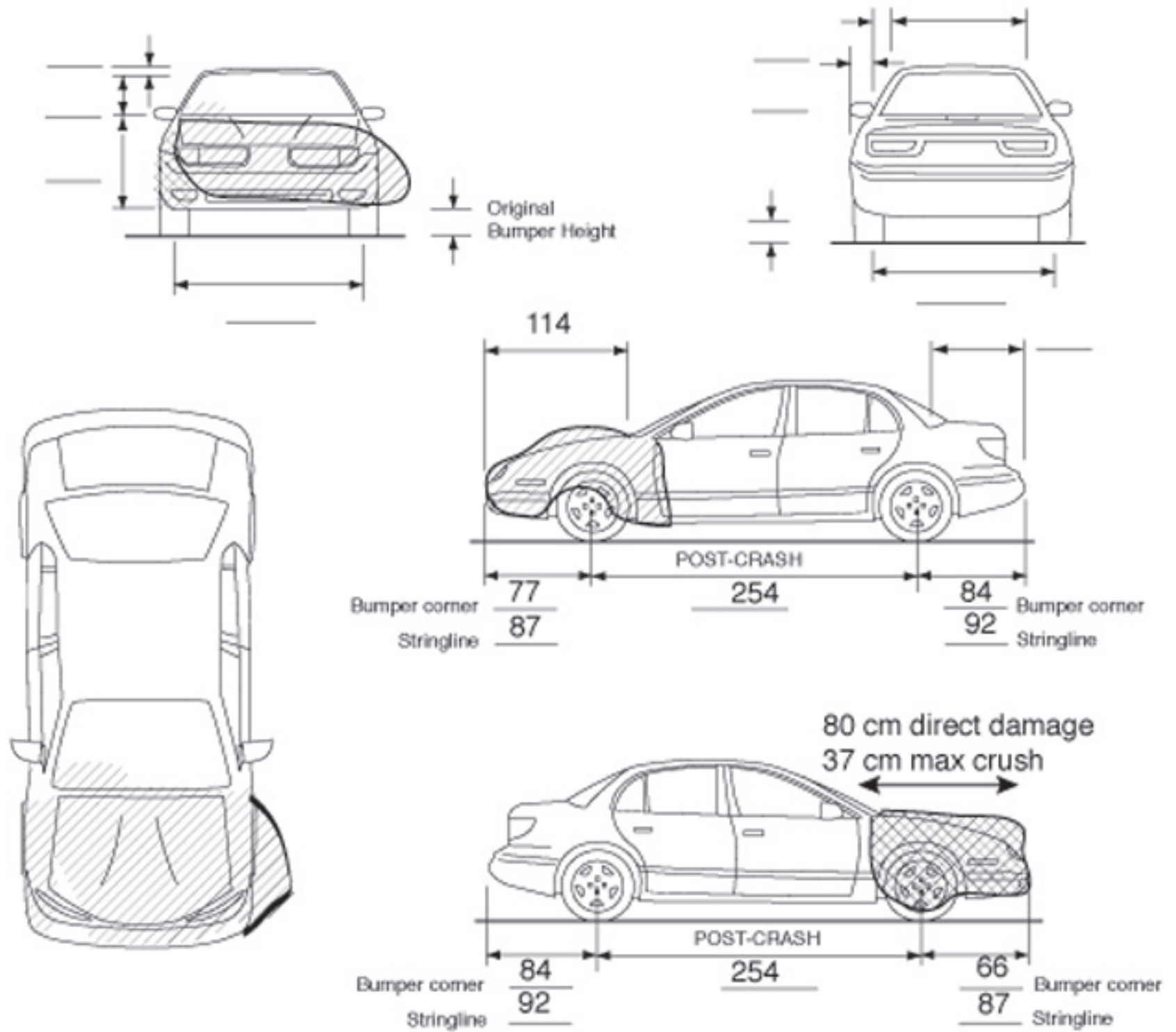

Passenger Airbag

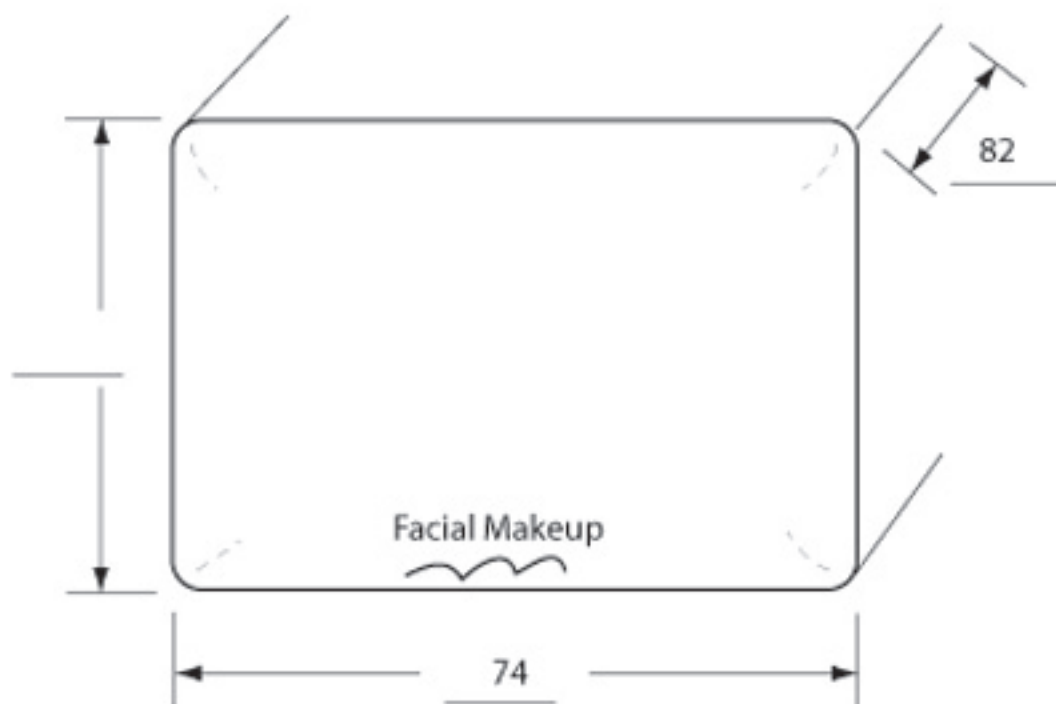

Vents: Y N
if yes, how many: 2

Tethers: Y N
if yes, how many: _____

Passenger Airbag Doors

H-Pattern

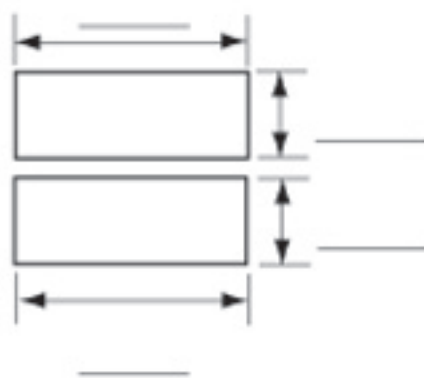

Single Door

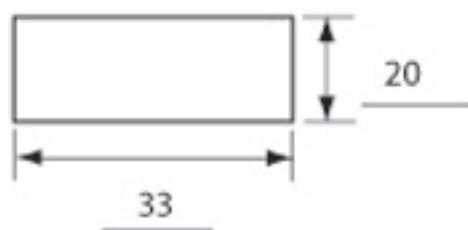





HEPLAGE
BELT





N

P









REPLACE
BELT























































20158 11/20
10-124



STOP AHEAD

2015 10000
10-10















BEWARE
OF DOG





BEWARE
of DOG

BEWARE
of DOG































STOP

STOP





