



US00D671067S

(12) **United States Design Patent**  
**Yasunaga**

(10) **Patent No.:** **US D671,067 S**

(45) **Date of Patent:** **\*\* Nov. 20, 2012**

(54) **TIRE**

(75) Inventor: **Toshikazu Yasunaga**, Osaka (JP)

(73) Assignee: **Toyo Tire & Rubber Co., Ltd.**, Osaka (JP)

(\*\*) Term: **14 Years**

(21) Appl. No.: **29/422,620**

(22) Filed: **May 22, 2012**

(30) **Foreign Application Priority Data**

Feb. 10, 2012 (JP) ..... 2012-002800

(51) **LOC (9) Cl.** ..... **12-15**

(52) **U.S. Cl.** ..... **D12/605**

(58) **Field of Classification Search** ..... D12/500-501,  
D12/544, 579, 600-605; 152/523-524, DIG. 12,  
152/555; D7/588, 396.4-396.5  
See application file for complete search history.

(56) **References Cited**

**U.S. PATENT DOCUMENTS**

|              |         |                |         |
|--------------|---------|----------------|---------|
| D477,810 S   | 7/2003  | Budich et al.  |         |
| D547,261 S * | 7/2007  | Shondel et al. | D12/605 |
| D557,202 S * | 12/2007 | Shondel        | D12/605 |
| D569,337 S * | 5/2008  | Iwabuchi       | D12/605 |

|              |         |               |         |
|--------------|---------|---------------|---------|
| D588,529 S * | 3/2009  | Reese et al.  | D12/605 |
| D593,939 S * | 6/2009  | Maxwell       | D12/605 |
| D597,480 S * | 8/2009  | Umstot et al. | D12/605 |
| D599,284 S   | 9/2009  | Misumi        |         |
| D605,583 S * | 12/2009 | Scheifele     | D12/605 |
| D606,488 S * | 12/2009 | Scheifele     | D12/605 |

\* cited by examiner

*Primary Examiner* — Stacia Cadmus

(74) *Attorney, Agent, or Firm* — Sterne, Kessler, Goldstein & Fox PLLC

(57) **CLAIM**

The ornamental design for a tire, as shown and described.

**DESCRIPTION**

FIG. 1 is a perspective view of a tire showing my new design; FIG. 2 is a front view thereof;

FIG. 3 is a rear view thereof;

FIG. 4 is a top plan view thereof, for which the bottom plan view is a mirror image;

FIG. 5 is a left side view thereof, for which the right side view is a mirror image;

FIG. 6 is an enlarged view taken along lines 6-6 and 6'-6' in FIG. 2; and,

FIG. 7 is a cross-sectional view taken along line 7-7 in FIG. 4 and lines 7'-7' and 7''-7'' in FIG. 6.

In the drawings, the broken lines showing portions of the tire tread, sidewall, and inner bead depict environmental subject matter that forms no part of the claimed design.

**1 Claim, 7 Drawing Sheets**

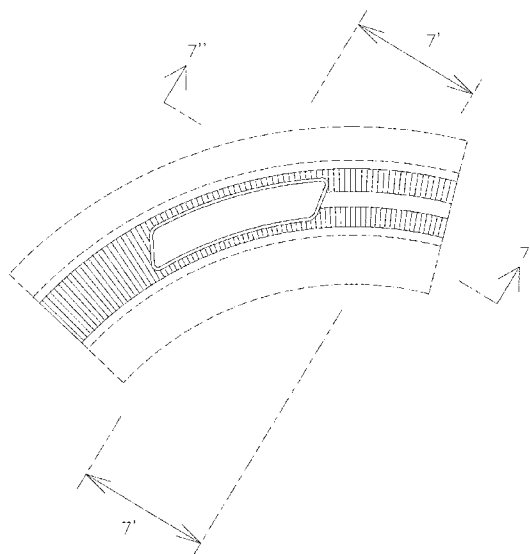
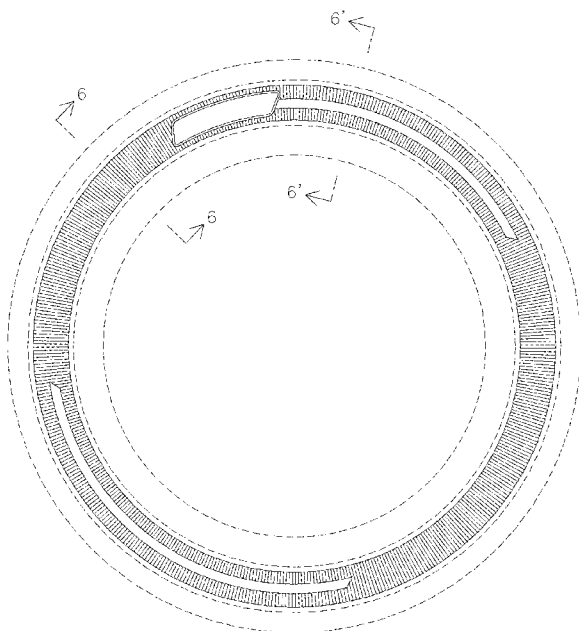

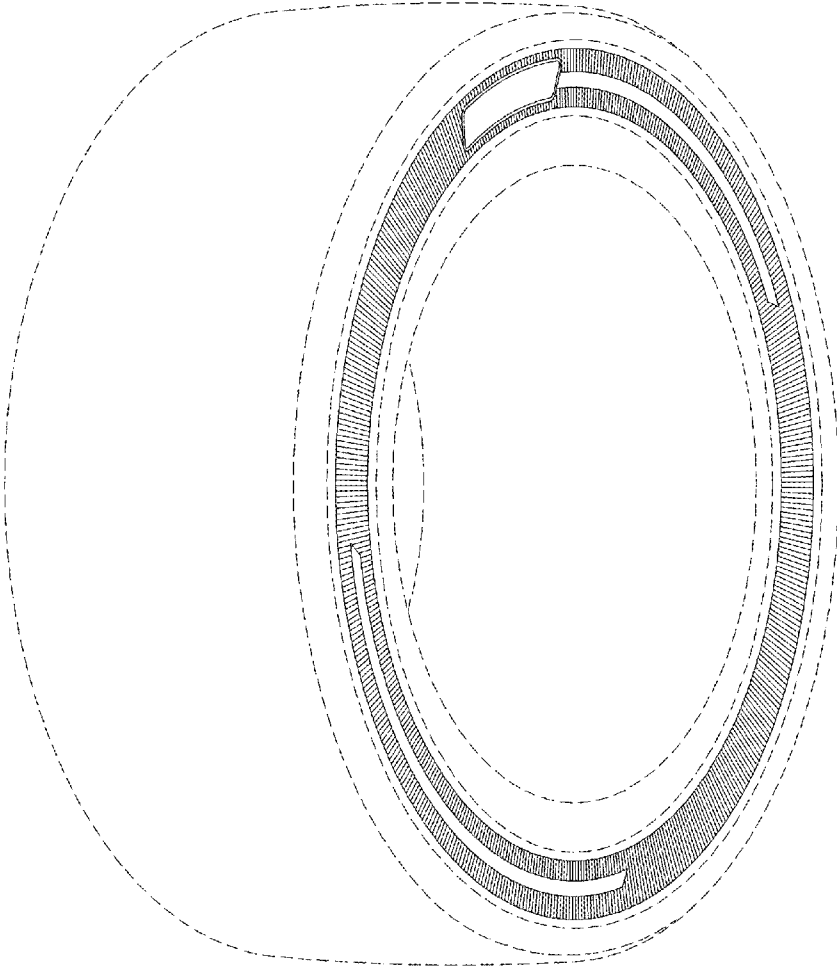

FIG. 1

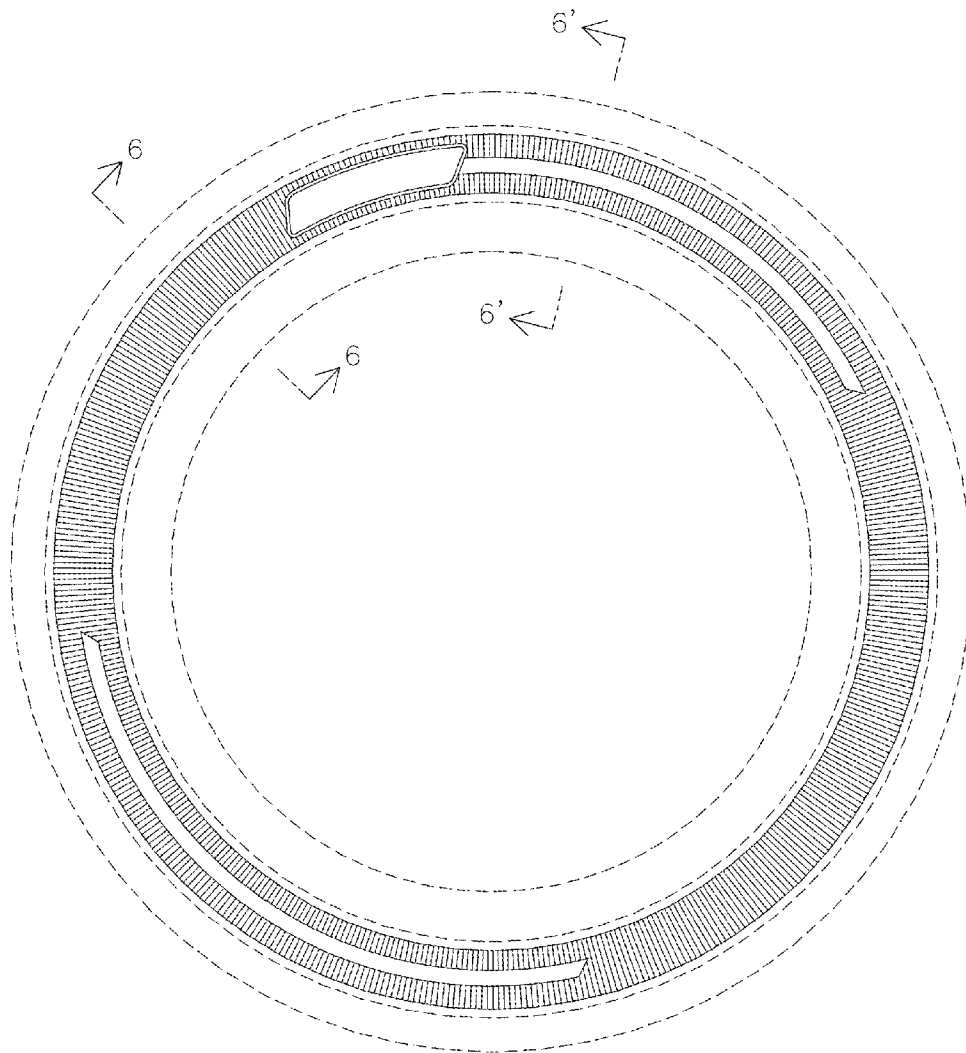

FIG. 2

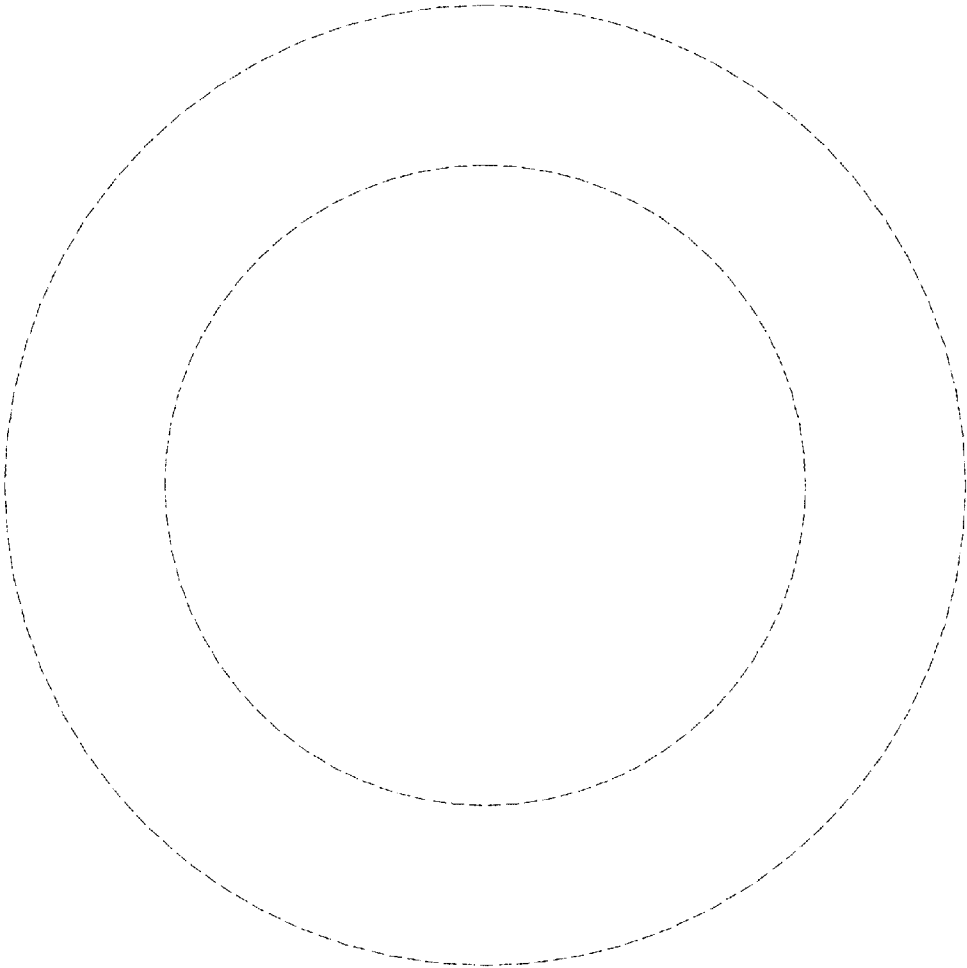

FIG. 3

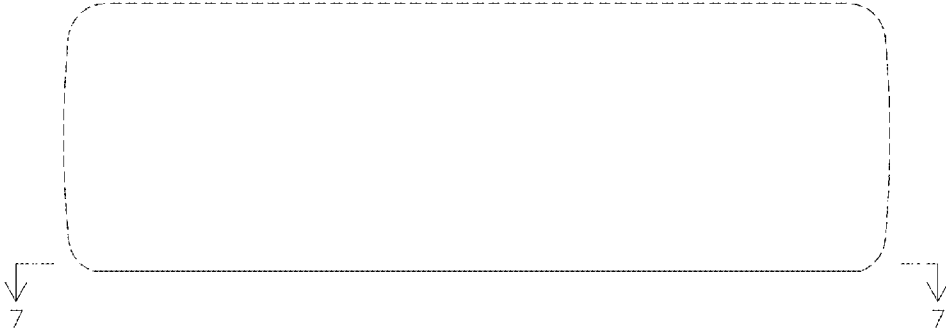
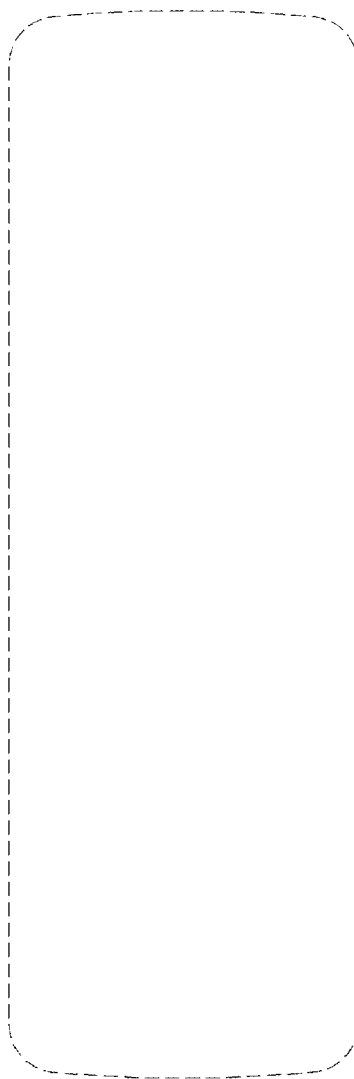

FIG. 4



**FIG. 5**

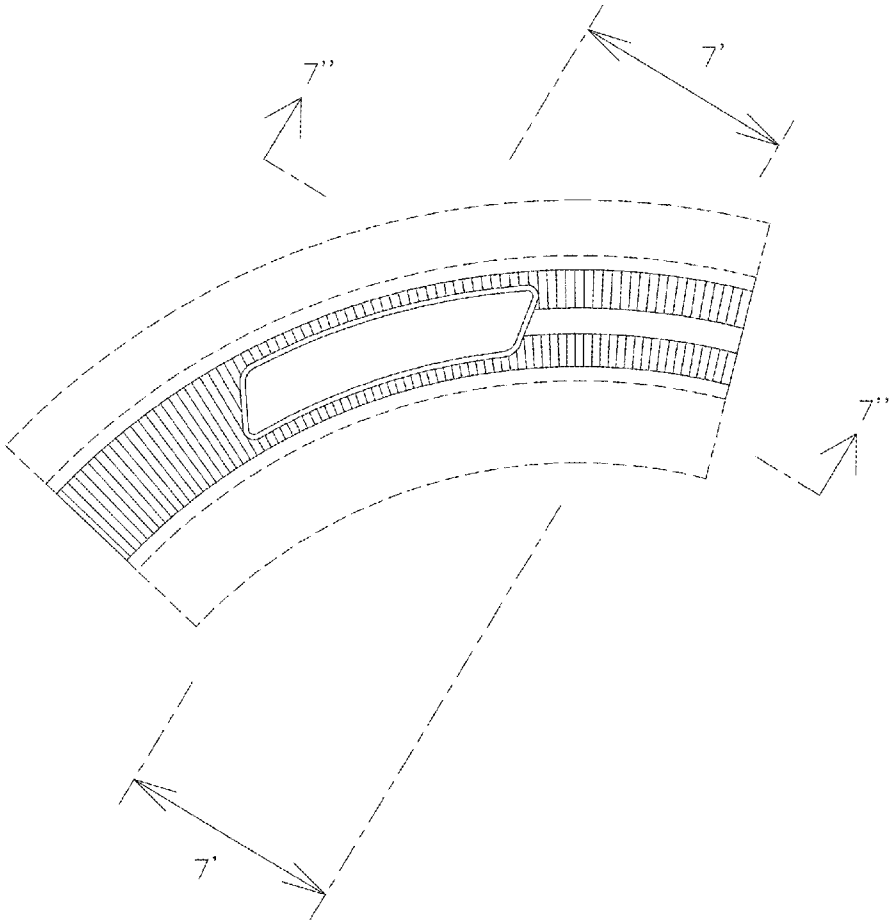

FIG. 6

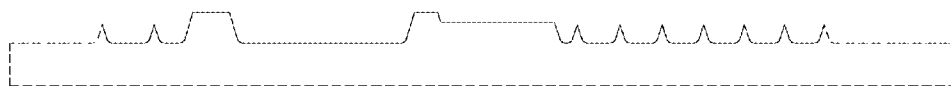

FIG. 7