



US00D671037S

(12) **United States Design Patent**
Wu et al.

(10) **Patent No.:** **US D671,037 S**

(45) **Date of Patent:** **** Nov. 20, 2012**

(54) **ALL TERRAIN VEHICLE**

(75) Inventors: **Wen-Yung Wu**, Kaohsiung (TW);
Kuo-Feng Huang, Kaohsiung (TW);
Chieh-Mao Chang, Kaohsiung (TW)

(73) Assignee: **Kwang Yang Motor Co., Ltd.**,
Kaohsiung (TW)

(**) Term: **14 Years**

(21) Appl. No.: **29/405,054**

(22) Filed: **Oct. 28, 2011**

(51) **LOC (9) Cl.** **12-11**

(52) **U.S. Cl.** **D12/107**

(58) **Field of Classification Search** D12/107,
D12/3, 86, 87, 110; 180/223, 225, 233, 229,
180/311, 312, 315

See application file for complete search history.

(56) **References Cited**

U.S. PATENT DOCUMENTS

D516,467 S * 3/2006 Wu D12/107

D529,414 S * 10/2006 Wu et al. D12/107
D585,792 S * 2/2009 Chao et al. D12/107
D620,399 S * 7/2010 Wu et al. D12/107

* cited by examiner

Primary Examiner — Susan M Lee

Assistant Examiner — Linda G. Brooks

(74) *Attorney, Agent, or Firm* — Leong C. Lei

(57) **CLAIM**

The ornamental design for an all terrain vehicle, as shown and described.

DESCRIPTION

FIG. 1 is a perspective view of an all terrain vehicle showing my new design;

FIG. 2 is a front elevational view thereof;

FIG. 3 is a rear elevational view thereof;

FIG. 4 is a left side elevational view thereof;

FIG. 5 is a right side elevational view thereof;

FIG. 6 is a top plan view thereof; and,

FIG. 7 is a bottom plan view thereof.

1 Claim, 7 Drawing Sheets

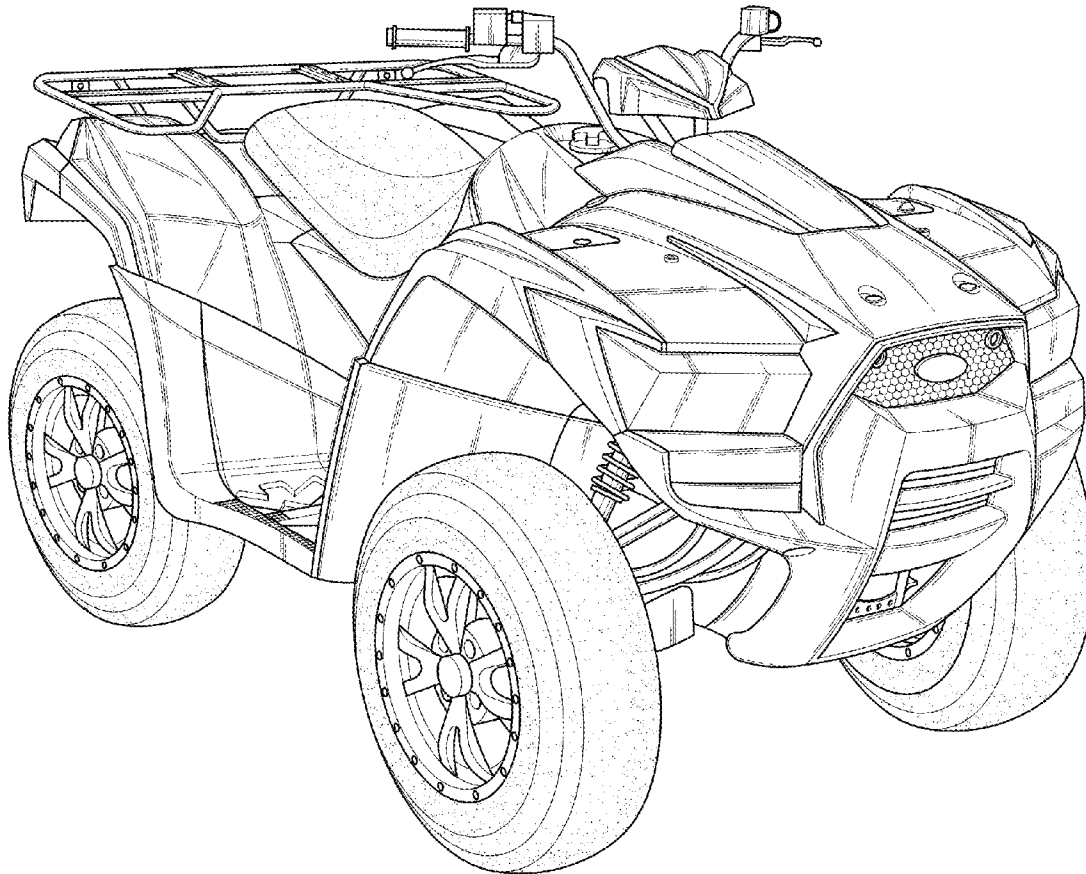

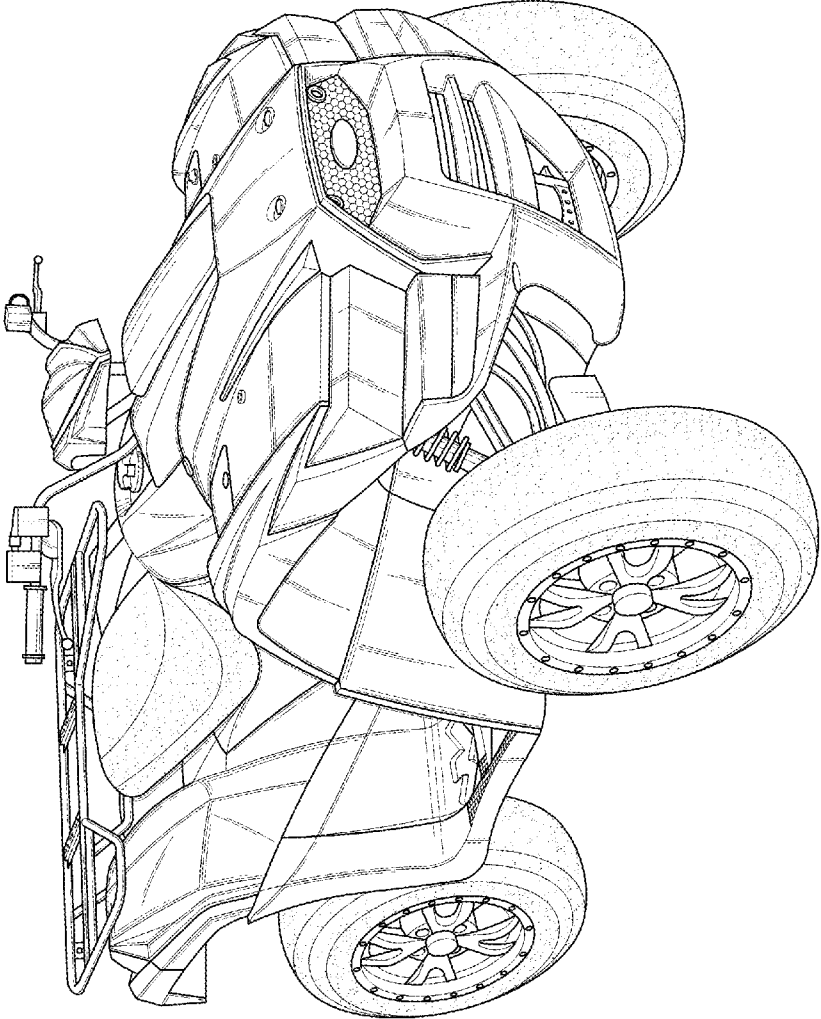

FIG.1

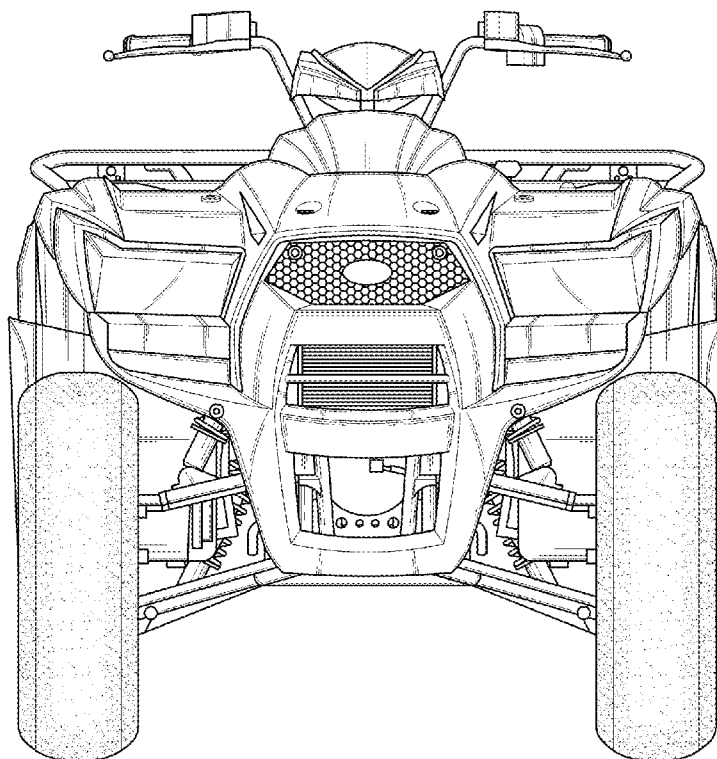

FIG.2

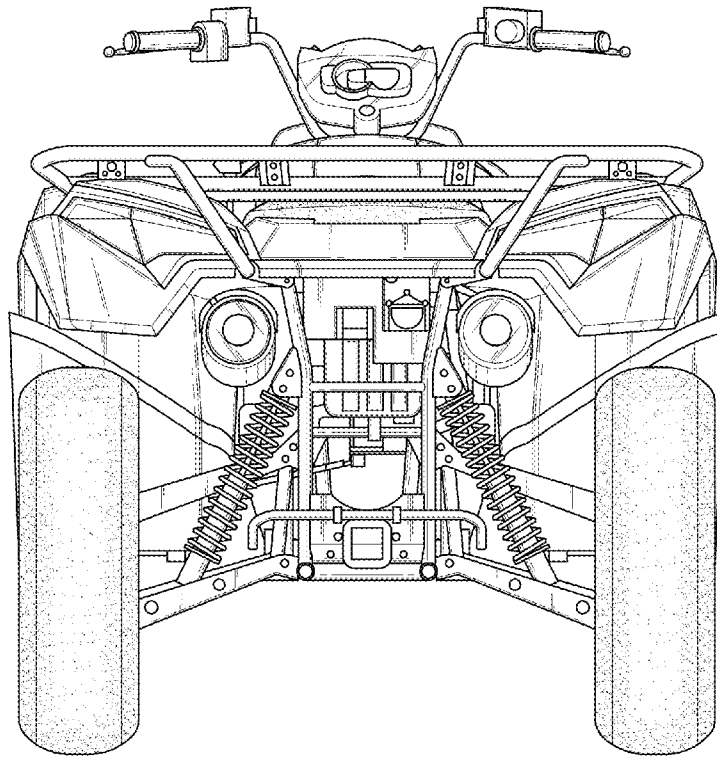

FIG.3

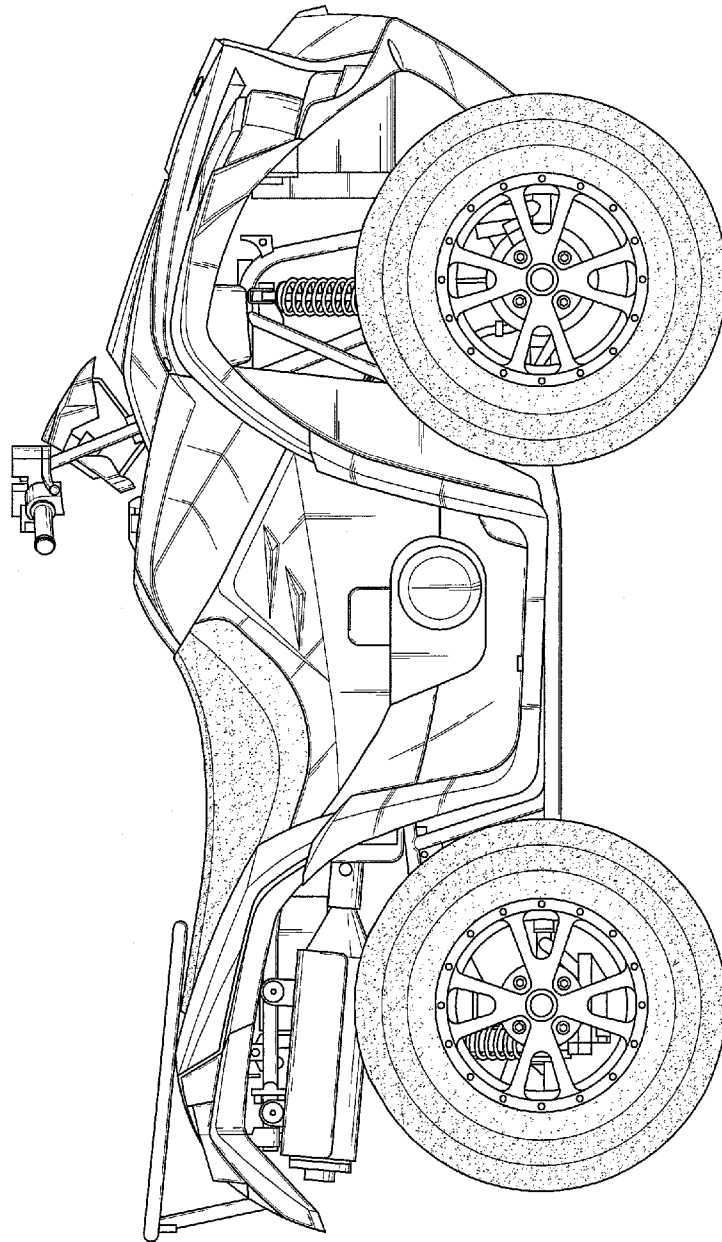

FIG.4

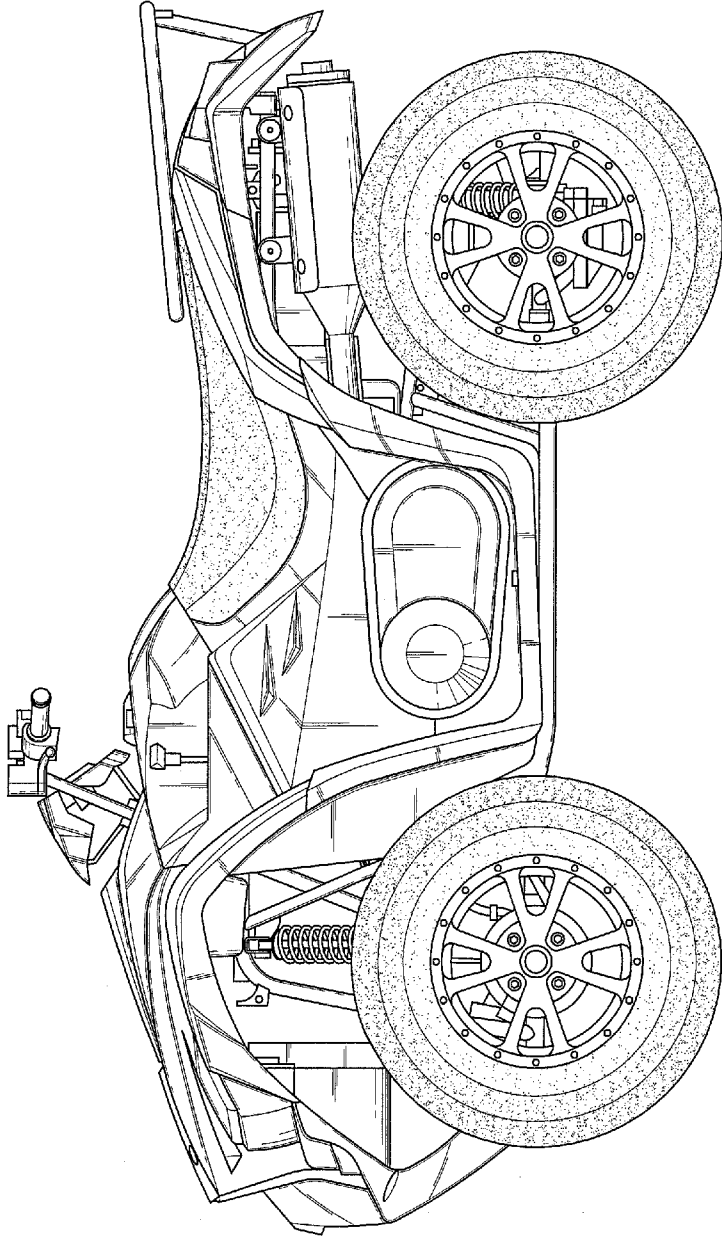

FIG.5

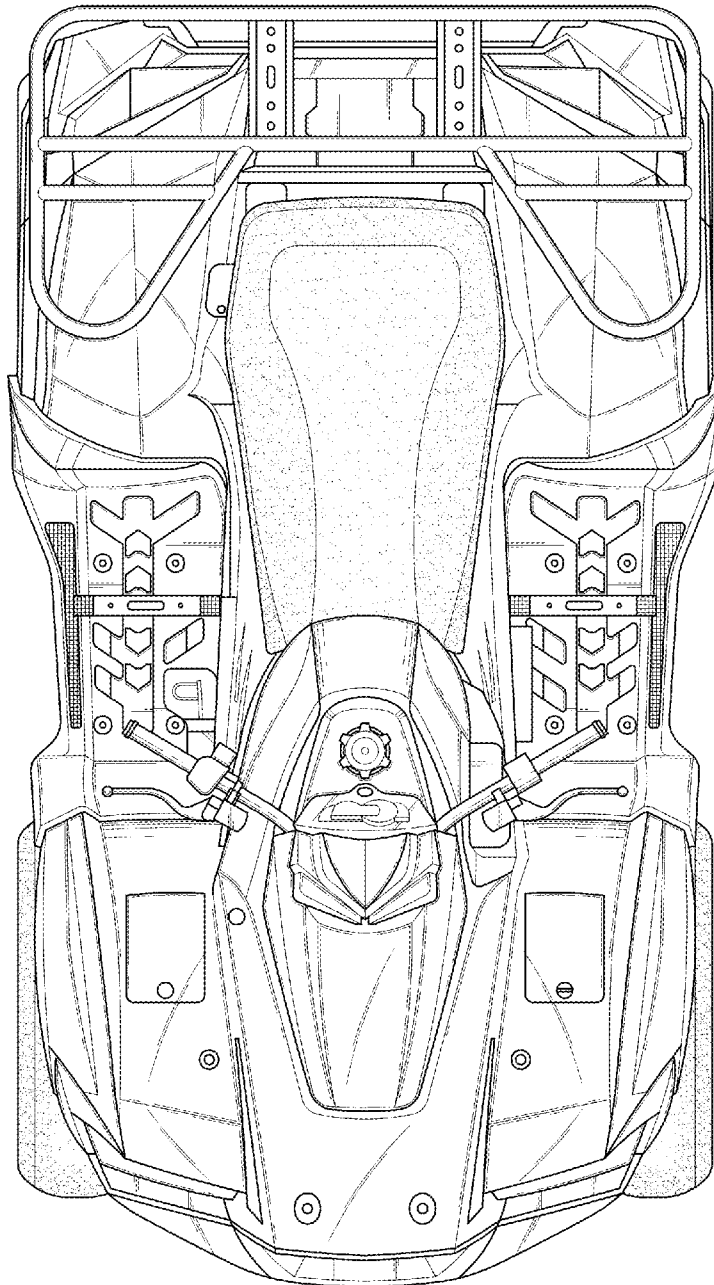

FIG.6

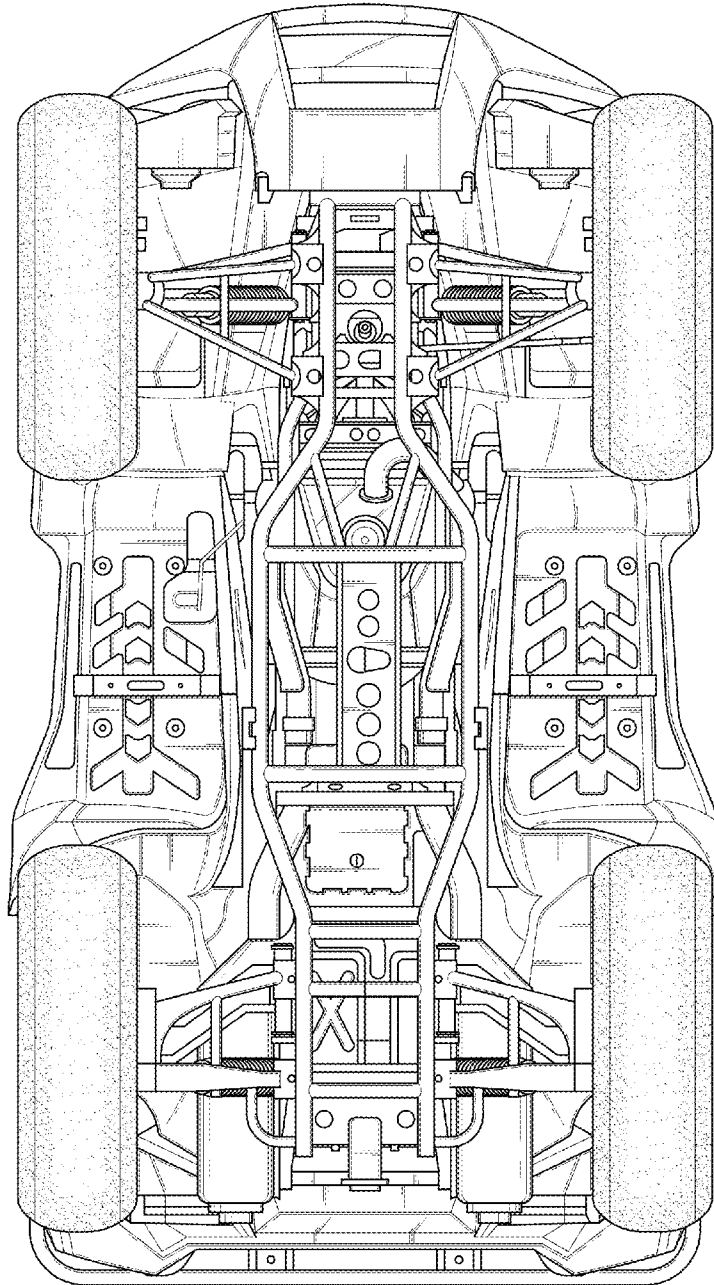

FIG.7