

January 31, 2011

SAFETY RECALL NOTICE

Dear valued Customer:

This notice is sent to you in accordance with the requirements of the National Traffic and Motor Vehicle Safety Act. Forest River, Inc. has decided that a defect which relates to motor vehicle safety exists in vehicles it manufactured with certain plug-in remote control receivers supplied by Dimplex North America, Ltd. These remote Controls receivers were used to operate the electric fireplace on your vehicle.

This decision was based upon information provided by Dimplex North America that a defect exists in some of the remote control receivers that Dimplex manufactured from 1998 through 2008. Forest River installed these kits as original or optional equipment in vehicles it manufactured from 2001 to 2009. Our records indicate that you may be the owner of one of the affected vehicles.

What Vehicles are Being Recalled?

The recall potentially affects the following vehicle makes and years: Cardinal, Georgetown 2001 to 2005. Cedar Creek-2003 to 2006 and 2009, Sierra/Sandpiper 2004, Wildwood/Salem 2004 & 2007, Berkshire/Charleston 2004-2005 and 2007, Rockwood/Flagstaff 2005 & 2007, Wildwood/ Salem laminated 2007.

Only the vehicles that were equipped with one of the following plug-in remote control kits models are covered by this recall:

Model No. 47-001

Model No. 47-1010-R

Model No. APT-1315

Doc. ID# 255K656-61-8367R (for older models that do not have a model number)

These plug-in remote control kits were sold individually and were also packaged with the following electric fireplaces: BF6000 and NNF5500.

What is the Problem?

In some instances, the plug-in remote control receiver can overheat, posing a fire hazard. You may continue to safely operate the electric fireplace when connected directly to an electrical outlet without the plug-in remote control receiver.

What We Will Do?

Forest River, in cooperation with Dimplex North America, will provide owners with a replacement remote control kit free of charge.

Note: This recall is being conducted simultaneously through NHTSA and the CPSC. If you have previously received notice of this recall and received your free replacement remote control kit, there is nothing further for you to do.

What Should You Do?

To receive a free replacement remote control kit, please do the following:

1. Locate your remote control receiver behind the electric fireplace on your vehicle (if applicable, refer to the attached guide, “Remote Control replacement Instructions for BF6000, NNF5500”); remove the receiver from the electrical outlet and unplug the fireplace from the receiver.
2. Locate the Model #/Doc. ID # and Date Code of the receiver using the enclosed bulletin, “How to Identify Recalled Plug-In Remote Receivers,” as a guide.
3. Confirm that your remote control receiver is covered by this recall by comparing the model number to the product list above. If your product is covered, please note the Model #/Doc. ID # and the Date Code in the space provided below and continue to Step 4.
The recalled receiver will be replaced with a new version, Model No. 1010-R* (note the asterisk*). On the new version the name “Dimplex” appears on the front of the receiver in red. If yours is a Model No. 1010-R*, your remote has been replaced and you can continue to use it, but you should provide the vehicle information listed in Step 4 to Dimplex North America Technical Customer Service at the number provided in Step 6.
4. Note the make, model, model year and the vehicle identification number (VIN) of your vehicle in the space provided.
5. Dispose of the receiver.
6. Contact Dimplex North America Technical Customer Service at 1-888-285-7773 from 8 am – 4:30 pm EST Monday through Friday. Please have your product and vehicle information readily available (as per Step 4).

If you need assistance locating the remote control receiver or locating the Model#/Doc. ID # or the Date Code on your receiver, you may contact Dimplex North America at the number listed in Step 6 for assistance.

If Dimplex North America or Forest River fail or are unable to provide a replacement remote control kit within a reasonable time, you may wish to contact the Administrator, National Highway traffic Safety Administration, 1200 New Jersey Avenue, SE, Washington, DC 20590, or call the toll-free Auto Safety Hotline at 1-888-327-4236 (TTY: 1-800-424-9153); or contact NHTSA at <http://www.safercar.gov>.

If you previously paid to replace a recalled Dimplex remote control receiver that failed due to this defect, you may be eligible to be reimbursed for your costs. Please contact Forest River, Inc. at 574-534-3167 to determine your eligibility.

If you no longer own the vehicle covered by this Safety Recall Notice, please provide the name and contact information for the new owner by calling Forest river at 574-534-3167. This will enable us to advise the new owner of the recall. Also, under Federal Law, any vehicle lessor receiving this recall notice must forward a copy of this notice to the lessee within 10 days.

We regret any inconvenience this may cause you, but we are initiating this action in the interest of your personal safety and satisfaction with our products.

Sincerely,

Forest River Customer Service

Enclosures: Remote Control Replacement Instructions for BF6000, BF6000*, DF2603, NNF5500
How to Identify Recalled Plug-In remote Control Receivers

INFORMATION TO BE PROVIDED TO DIMPLEX NORTH AMERICA, LTD

Remote Control Receiver:

Model #/Doc. ID# _____

Date Code _____

Vehicle:

Make _____

Model _____

Year _____

Vehicle Identification Number (VIN) (17 digits) _____

Remote Control Replacement Instructions For BF6000, BF6000*, DF2603, NNF5500

- 1) Remove the fireplace from its installed location to access the plug-in remote control behind the unit.
- 2) If the fireplace is fixed in place, follow the following instructions for fireplace removal:

- a) Remove retaining clip using a slot screwdriver

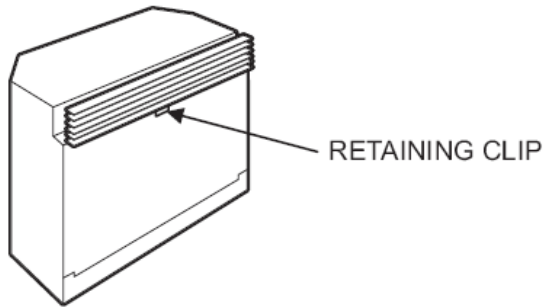

- b) Remove glass

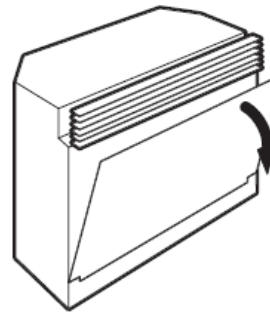

- c) Remove log set

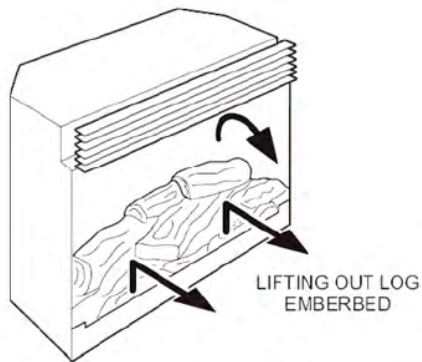

- d) Remove the screws that fasten the bottom of the fireplace to the floor.

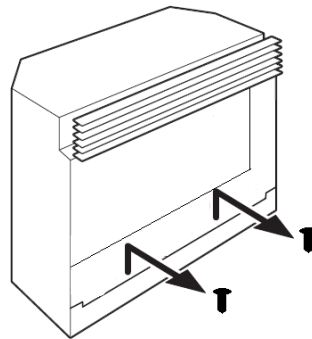

- e) Pull the fireplace from its installed location to access the plug-in remote control.

If you need assistance locating the remote control receiver or removing the fireplace to access the remote, please contact Dimplex North America Technical Customer Service at 1-888-DIMPLEX (1-888-346-7539) from 8 am – 4:30 pm Eastern Monday through Friday; when prompted, press “1” for “Customer Service” and then “1” again for “Parts Service and Technical Support”.

How to identify recalled plug-in remote control receivers:

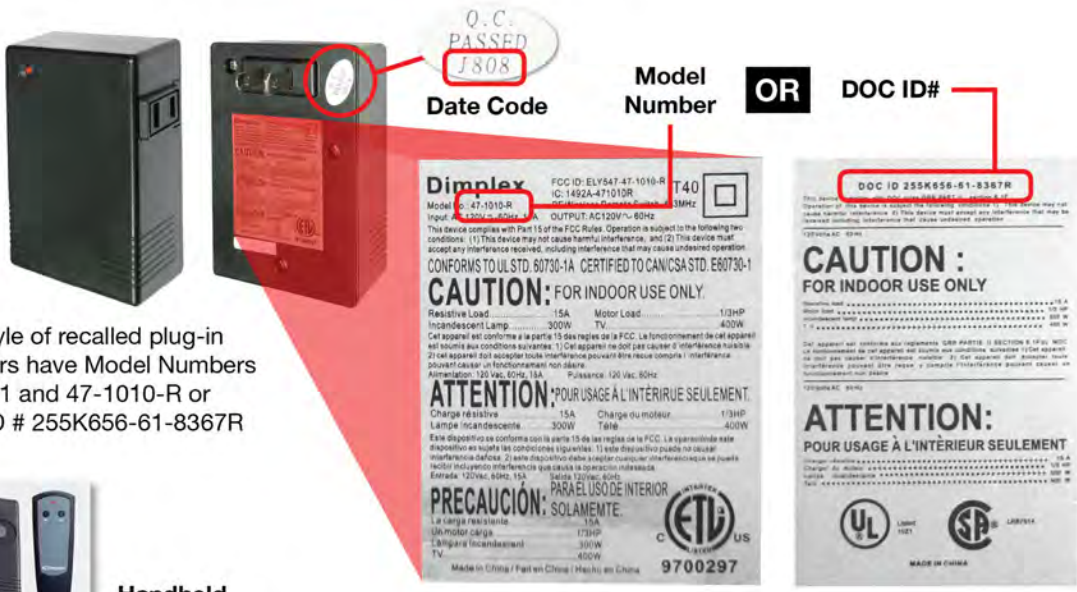

This style of recalled plug-in receivers have Model Numbers 47-1001 and 47-1010-R or DOC ID # 255K656-61-8367R



Handheld Transmitters

This style of recalled plug-in receiver has Model Number APT-1315

