

Subtitle B—Other Regulations
Relating to Transportation
(Continued)

CHAPTER V—NATIONAL HIGHWAY TRAFFIC
SAFETY ADMINISTRATION, DEPARTMENT OF
TRANSPORTATION (CONTINUED)

<i>Part</i>		<i>Page</i>
572	Anthropomorphic test devices	7
573	Defect and noncompliance responsibility and re- ports	160
574	Tire identification and recordkeeping	173
575	Consumer information	182
576	Record retention	220
577	Defect and noncompliance notification	221
578	Civil and criminal penalties	231
579	Reporting of information and communications about potential defects	234
580	Odometer disclosure requirements	258
581	Bumper standard	267
582	Insurance cost information regulation	271
583	Automobile parts content labeling	272
585	Phase-in reporting requirements	284
586	[Reserved]	
587	Deformable barriers	299
588	Child restraint systems recordkeeping require- ments	308
589–590	[Reserved]	
591	Importation of vehicles and equipment subject to Federal safety, bumper and theft prevention standards	309
592	Registered importers of vehicles not originally manufactured to conform to the Federal motor vehicle safety standards	320
593	Determinations that a vehicle not originally man- ufactured to conform to the Federal motor vehi- cle safety standards is eligible for importation ...	333
594	Schedule of fees authorized by 49 U.S.C. 30141	347
595	Make inoperative exemptions	351
596–598	[Reserved]	

49 CFR Ch. V (10-1-10 Edition)

<i>Part</i>		<i>Page</i>
599	Requirements and procedures for Consumer Assistance to Recycle and Save Act program	368

PART 572—ANTHROPOMORPHIC TEST DEVICES

Subpart A—General

- Sec.
572.1 Scope.
572.2 Purpose.
572.3 Application.
572.4 Terminology.

Subpart B—50th Percentile Male

- 572.5 General description.
572.6 Head.
572.7 Neck.
572.8 Thorax.
572.9 Lumbar spine, abdomen, and pelvis.
572.10 Limbs.
572.11 Test conditions and instrumentation.

Subpart C—3-Year-Old Child

- 572.15 General description.
572.16 Head.
572.17 Neck.
572.18 Thorax.
572.19 Lumbar spine, abdomen and pelvis.
572.20 Limbs.
572.21 Test conditions and instrumentation.

Subpart D—6-Month-Old Infant

- 572.25 General description.

Subpart E—Hybrid III Test Dummy

- 572.30 Incorporated materials.
572.31 General description.
572.32 Head.
572.33 Neck.
572.34 Thorax.
572.35 Limbs.
572.36 Test conditions and instrumentation.

Subpart F—Side Impact Dummy 50th Percentile Male

- 572.40 Incorporated materials.
572.41 General description.
572.42 Thorax.
572.43 Lumbar spine and pelvis.
572.44 Instrumentation and test conditions.

APPENDIX A TO SUBPART F

Subparts G—H [Reserved]

Subpart I—6-Year-Old Child

- 572.70 Incorporation by reference.
572.71 General description.
572.72 Head assembly and test procedure.
572.73 Neck assembly and test procedure.
572.74 Thorax assembly and test procedure.
572.75 Lumbar spine, abdomen, and pelvis assembly and test procedure.
572.76 Limbs assembly and test procedure.

- 572.77 Instrumentation.
572.78 Performance test conditions.

FIGURES TO SUBPART I

Subpart J—9-Month Old Child

- 572.80 Incorporated materials.
572.81 General description.
572.82 Head.
572.83 Head-neck.
572.84 Thorax.
572.85 Lumbar spine flexure.
572.86 Test conditions and dummy adjustment.

Subpart K—Newborn Infant

- 572.90 Incorporation by reference.
572.91 General description.

Subpart L—Free Motion Headform

- 572.100 Incorporation by reference.
572.101 General description.
572.102 Drop test.
572.103 Test conditions and instrumentation.

Subpart M—Side Impact Hybrid Dummy 50th Percentile Male.

- 572.110 Materials incorporated by reference.
572.111 General description.
572.112 Head assembly.
572.113 Neck assembly.
572.114 Thorax.
572.115 Lumbar spine and pelvis.
572.116 Instrumentation and test conditions.

Subpart N—Six-year-old Child Test Dummy, Beta Version

- 572.120 Incorporation by reference.
572.121 General description.
572.122 Head assembly and test procedure.
572.123 Neck assembly and test procedure.
572.124 Thorax assembly and test procedure.
572.125 Upper and lower torso assemblies and torso flexion test procedure.
572.126 Knees and knee impact test procedure.
572.127 Test conditions and instrumentation.

FIGURES TO SUBPART N

Subpart O—Hybrid III 5th Percentile Female Test Dummy, Alpha Version

- 572.130 Incorporation by reference.
572.131 General description.
572.132 Head assembly and test procedure.
572.133 Neck assembly and test procedure.
572.134 Thorax assembly and test procedure.
572.135 Upper and lower torso assemblies and torso flexion test procedure.
572.136 Knees and knee impact test procedure.

§ 572.1

572.137 Test conditions and instrumentation.

FIGURES TO SUBPART O

Subpart P—Hybrid III 3-Year-Old Child Crash Test Dummy, Alpha Version

572.140 Incorporation by reference.
572.141 General description.
572.142 Head assembly and test procedure.
572.143 Neck-headform assembly and test procedure.
572.144 Thorax assembly and test procedure.
572.145 Upper and lower torso assemblies and torso flexion test procedure.
572.146 Test condition and instrumentation.

FIGURES TO SUBPART P

Subpart R—CRABI 12-Month-Old Infant Crash Test Dummy, Alpha Version

572.150 Incorporation by reference.
572.151 General description.
572.152 Head assembly and test procedure.
572.153 Neck-headform assembly and test procedure.
572.154 Thorax assembly and test procedure.
572.155 Test condition and instrumentation.

FIGURES TO SUBPART R

Subpart S—Hybrid III Six-Year-Old Weighted Child Test Dummy

572.160 Incorporation by reference.
572.161 General description.
572.162 Head assembly and test procedure.
572.163 Neck assembly and test procedure.
572.164 Thorax assembly and test procedure.
572.165 Upper and lower torso assemblies and torso flexion test procedure.
572.166 Knees and knee impact test procedure.
572.167 Test conditions and instrumentation.

FIGURES TO SUBPART S

Subpart T [Reserved]

Subpart U—ES-2re Side Impact Crash Test Dummy, 50th Percentile Adult Male

572.180 Incorporated materials.
572.181 General description.
572.182 Head assembly.
572.183 Neck assembly.
572.184 Shoulder assembly.
572.185 Thorax (upper torso) assembly.
572.186 Abdomen assembly.
572.187 Lumbar spine.
572.188 Pelvis.
572.189 Instrumentation and test conditions.

APPENDIX A TO SUBPART U OF PART 572—FIGURES

49 CFR Ch. V (10–1–10 Edition)

Subpart V, SID-ILsD Side Impact Crash Test Dummy, Small Adult Female

572.190 Incorporated materials.
572.191 General description.
572.192 Head assembly.
572.193 Neck assembly.
572.194 Shoulder.
572.195 Thorax with arm.
572.196 Thorax without arm.
572.197 Abdomen.
572.198 Pelvis acetabulum.
572.199 Pelvis iliac.
572.200 Instrumentation and test conditions.

APPENDIX A TO SUBPART V OF PART 572—FIGURES

AUTHORITY: 49 U.S.C. 322, 30111, 30115, 30117 and 30166; delegation of authority at 49 CFR 1.50.

EDITORIAL NOTES: 1. For compliance provisions relating to a vehicle's conformance with the performance requirements of Standard No. 208 (§ 571.208) relating to the part 572 test dummy, see the "Effective Date Note" at subpart E of this part.

2. Nomenclature changes to part 572 appear at 69 FR 18803, Apr. 9, 2004.

Subpart A—General

§ 572.1 Scope.

This part describes the anthropomorphic test devices that are to be used for compliance testing of motor vehicles and motor vehicle equipment with motor vehicle safety standards.

[60 FR 43058, Aug. 18, 1995]

§ 572.2 Purpose.

The design and performance criteria specified in this part are intended to describe measuring tools with sufficient precision to give repetitive and correlative results under similar test conditions and to reflect adequately the protective performance of a vehicle or item of motor vehicle equipment with respect to human occupants.

[38 FR 20451, Aug. 1, 1973, as amended at 42 FR 7151, Feb. 7, 1977]

§ 572.3 Application.

This part does not in itself impose duties or liabilities on any person. It is a description of tools that measure the performance of occupant protection systems required by the safety standards that incorporate it. It is designed to be referenced by, and become a part

of, the test procedures specified in motor vehicle safety standards such as Standard No. 208, Occupant Crash Protection.

[38 FR 20451, Aug. 1, 1973, as amended at 42 FR 7152, Feb. 7, 1977]

§ 572.4 Terminology.

(a) The term *dummy*, when used in this subpart A, refers to any test device described by this part. The term *dummy*, when used in any other subpart of this part, refers to the particular dummy described in that part.

(b) Terms describing parts of the dummy, such as *head*, are the same as names for corresponding parts of the human body.

(c) The term *unimodal*, when used in subparts C and I, refers to an acceleration-time curve which has only one prominent peak.

[38 FR 20451, Aug. 1, 1973, as amended at 42 FR 7152, Feb. 7, 1977; 44 FR 76530, Dec. 27, 1979; 56 FR 57836, Nov. 14, 1991]

Subpart B—50th Percentile Male

§ 572.5 General description.

(a) The dummy consists of the component assemblies specified in Figure 1, which are described in their entirety by means of approximately 250 drawings and specifications that are grouped by component assemblies under the following nine headings:

SA 150 M070—Right arm assembly
 SA 150 M071—Left arm assembly
 SA 150 M050—Lumbar spine assembly
 SA 150 M060—Pelvis and abdomen assembly
 SA 150 M080—Right leg assembly
 SA 150 M081—Left leg assembly
 SA 150 M010—Head assembly
 SA 150 M020—Neck assembly
 SA 150 M030—Shoulder-thorax assembly.

(b) The drawings and specifications referred to in this regulation that are not set forth in full are hereby incorporated in this part by reference. These materials are thereby made part of this regulation. The Director of the Federal Register has approved the materials incorporated by reference. For materials subject to change, only the specific version approved by the Director of the Federal Register and specified in the regulation are incorporated. A notice of any change will be published in the

FEDERAL REGISTER. As a convenience to the reader, the materials incorporated by reference are listed in the Finding Aid Table found at the end of this volume of the Code of Federal Regulations.

(c) The materials incorporated by reference are available for examination in Docket 73-08, Docket Section, National Highway Traffic Safety Administration, Room 5109, 400 Seventh Street SW., Washington, DC, 20590. Copies may be obtained from Rowley-Scher Reprographics, Inc., 1216 K Street NW., Washington, DC 20005 ((202) 628-6667). The drawings and specifications are also on file in the reference library of the Office of the Federal Register, National Archives and Records Administration, Washington, DC.

(d) Adjacent segments are joined in a manner such that throughout the range of motion and also under crash impact conditions there is no contact between metallic elements except for contacts that exist under static conditions.

(e) The structural properties of the dummy are such that the dummy conforms to this part in every respect both before and after being used in vehicle tests specified in Standard No. 208 of this chapter (571.208).

(f) A specimen of the dummy is available for surface measurements and access can be arranged by contacting: Office of Vehicle Safety Standards, National Highway Traffic Safety Administration, 400 Seventh Street, SW., Washington, DC 20590.

[50 FR 25423, June 19, 1985]

§ 572.6 Head.

(a) The head consists of the assembly shown as number SA 150 M010 in Figure 1 and conforms to each of the drawings subtended by number SA 150 M010.

(b) When the head is dropped from a height of 10 inches in accordance with paragraph (c) of this section, the peak resultant accelerations at the location of the accelerometers mounted in the head form in accordance with § 572.11(b) shall be not less than 210g, and not more than 260g. The acceleration/time curve for the test shall be unimodal and shall lie at or above the 100g level

§572.7

for an interval not less than 0.9 milliseconds and not more than 1.5 milliseconds. The lateral acceleration vector shall not exceed 10g.

(c) Test procedure:

(1) Suspend the head as shown in Figure 2, so that the lowest point on the forehead is 0.5 inches below the lowest point on the dummy's nose when the midsagittal plane is vertical.

(2) Drop the head from the specified height by means that ensures instant release onto a rigidly supported flat horizontal steel plate, 2 inches thick and 2 feet square, which has a clean, dry surface and any microfinish of not less than 8 microinches (rms) and not more than 80 microinches (rms).

(3) Allow a time period of at least 2 hours between successive tests on the same head.

[38 FR 20451, Aug. 1, 1973, as amended at 42 FR 7152, Feb. 7, 1977]

§572.7 Neck.

(a) The neck consists of the assembly shown as number SA 150 M020 in Figure 1 and conforms to each of the drawings subtended by number SA 150 M020.

(b) When the neck is tested with the head in accordance with paragraph (c) of this section, the head shall rotate in reference to the pendulum's longitudinal centerline a total of $68^\circ \pm 5^\circ$ about its center of gravity, rotating to the extent specified in the following table at each indicated point in time, measured from impact, with a chordal displacement measured at its center of gravity that is within the limits specified. The chordal displacement at time T is defined as the straight line distance between (1) the position relative to the pendulum arm of the head center of gravity at time zero, and (2) the position relative to the pendulum arm of the head center of gravity at time T as illustrated by Figure 3. The peak resultant acceleration recorded at the location of the accelerometers mounted in the head form in accordance with §572.11(b) shall not exceed 26g. The pendulum shall not reverse direction until the head's center of gravity returns to the original zero time position relative to the pendulum arm.

49 CFR Ch. V (10-1-10 Edition)

Rotation (degrees)	Time (ms) $\pm(2+.08T)$	Chordal Displacement (inches ± 0.5)
0	0	0.0
30	30	2.6
60	46	4.8
Maximum	60	5.5
60	75	4.8
30	95	2.6
0	112	0.0

(c) Test procedure: (1) Mount the head and neck on a rigid pendulum as specified in Figure 4, so that the head's midsagittal plane is vertical and coincides with the plane of motion of the pendulum's longitudinal centerline. Mount the neck directly to the pendulum as shown in Figure 4.

(2) Release the pendulum and allow it to fall freely from a height such that the velocity at impact is 23.5 ± 2.0 feet per second (fps), measured at the center of the accelerometer specified in Figure 4.

(3) Decelerate the pendulum to a stop with an acceleration-time pulse described as follows:

(i) Establish 5g and 20g levels on the a-t curve.

(ii) Establish t_1 at the point where the rising a-t curve first crosses the 5g level, t_2 at the point where the rising a-t curve first crosses the 20g level, t_3 at the point where the decaying a-t curve last crosses the 20g level, and t_4 at the point where the decaying a-t curve first crosses the 5g level.

(iii) $t_2 - t_1$ shall be not more than 3 milliseconds.

(iv) $t_3 - t_2$ shall be not less than 25 milliseconds and not more than 30 milliseconds.

(v) $t_4 - t_3$ shall be not more than 10 milliseconds.

(vi) The average deceleration between t_2 and t_3 shall be not less than 20g and not more than 24g.

(4) Allow the neck to flex without impact of the head or neck with any object other than the pendulum arm.

[38 FR 20451, Aug. 1, 1973, as amended at 42 FR 7152, Feb. 7, 1977; 42 FR 12176, Mar. 3, 1977; 45 FR 40596, June 16, 1980]

§572.8 Thorax.

(a) The thorax consists of the assembly shown as number SA 150 M030 in Figure 1, and conforms to each of the

drawings subtended by number SA 150 M030.

(b) The thorax contains enough unobstructed interior space behind the rib cage to permit the midpoint of the sternum to be depressed 2 inches without contact between the rib cage and other parts of the dummy or its instrumentation, except for instruments specified in paragraph (d)(7) of this section.

(c) When impacted by a test probe conforming to §572.11(a) at 14 fps and at 22 fps in accordance with paragraph (d) of this section, the thorax shall resist with forces measured by the test probe of not more than 1450 pounds and 2250 pounds, respectively, and shall deflect by amounts not greater than 1.1 inches and 1.7 inches, respectively. The internal hysteresis in each impact shall not be less than 50 percent and not more than 70 percent.

(d) Test procedure: (1) With the dummy seated without back support on a surface as specified in §572.11(i) and in the orientation specified in §572.11(i), adjust the dummy arms and legs until they are extended horizontally forward parallel to the midsagittal plane.

(2) Place the longitudinal center line of the test probe so that it is 17.7 ±0.1 inches above the seating surface at impact.

(3) Align the test probe specified in §572.11(a) so that at impact its longitudinal centerline coincides within 2 degrees of a horizontal line in the dummy's midsagittal plane.

(4) Adjust the dummy so that the surface area on the thorax immediately adjacent to the projected longitudinal center line of the test probe is vertical. Limb support, as needed to achieve and maintain this orientation, may be provided by placement of a steel rod of any diameter not less than one-quarter of an inch and not more than three-eighths of an inch, with hemispherical ends, vertically under the limb at its projected geometric center.

(5) Impact the thorax with the test probe so that its longitudinal centerline falls within 2 degrees of a horizontal line in the dummy's midsagittal plane at the moment of impact.

(6) Guide the probe during impact so that it moves with no significant lateral, vertical, or rotational movement.

(7) Measure the horizontal deflection of the sternum relative to the thoracic spine along the line established by the longitudinal centerline of the probe at the moment of impact, using a potentiometer mounted inside the sternum.

(8) Measure hysteresis by determining the ratio of the area between the loading and unloading portions of the force deflection curve to the area under the loading portion of the curve.

[38 FR 20451, Aug. 1, 1973, as amended at 42 FR 7152, Feb. 7, 1977]

§572.9 Lumbar spine, abdomen, and pelvis.

(a) The lumbar spine, abdomen, and pelvis consist of the assemblies designated as numbers SA 150 M050 and SA 150 M060 in Figure 1 and conform to the drawings subtended by these numbers.

(b) When subjected to continuously applied force in accordance with paragraph (c) of this section, the lumbar spine assembly shall flex by an amount that permits the rigid thoracic spine to rotate from its initial position in accordance with Figure 11 by the number of degrees shown below at each specified force level, and straighten upon removal of the force to within 12 degrees of its initial position in accordance with Figure 11.

Flexion (degrees)	Force (±6 pounds)
0	0
20	28
30	40
40	52

(c) Test procedure: (1) Assemble the thorax, lumbar spine, pelvic, and upper leg assemblies (above the femur force transducers), ensuring that all component surfaces are clean, dry, and untreated unless otherwise specified, and attach them to the horizontal fixture shown in Figure 5 at the two link rod pins and with the mounting brackets for the lumbar test fixtures illustrated in Figures 6 to 9.

(2) Attach the rear mounting of the pelvis to the pelvic instrument cavity rear face at the four ¼" cap screw holes and attach the front mounting at the femur axial rotation joint. Tighten the

§572.10

mountings so that the pelvic-lumbar adapter is horizontal and adjust the femur friction plungers at each hip socket joint to 240 inch-pounds torque.

(3) Flex the thorax forward 50° and then rearward as necessary to return it to its initial position in accordance with Figure 11 unsupported by external means.

(4) Apply a forward force perpendicular to the thorax instrument cavity rear face in the midsagittal plane 15 inches above the top surface of the pelvic-lumbar adapter. Apply the force at any torso deflection rate between .5 and 1.5 degrees per second up to 40° of flexion but no further, continue to apply for 10 seconds that force necessary to maintain 40° of flexion, and record the force with an instrument mounted to the thorax as shown in Figure 5. Release all force as rapidly as possible and measure the return angle 3 minutes after the release.

(d) When the abdomen is subjected to continuously applied force in accordance with paragraph (e) of this section, the abdominal force-deflection curve shall be within the two curves plotted in Figure 10.

(e) Test procedure: (1) Place the assembled thorax, lumbar spine and pelvic assemblies in a supine position on a flat, rigid, smooth, dry, clean horizontal surface, ensuring that all component surfaces are clean, dry, and untreated unless otherwise specified.

(2) Place a rigid cylinder 6 inches in diameter and 18 inches long transversely across the abdomen, so that the cylinder is symmetrical about the midsagittal plane, with its longitudinal centerline horizontal and perpendicular to the midsagittal plane at a point 9.2 inches above the bottom line of the buttocks, measured with the dummy positioned in accordance with Figure 11.

(3) Establish the zero deflection point as the point at which a force of 10 pounds has been reached.

(4) Apply a vertical downward force through the cylinder at any rate between 0.25 and 0.35 inches per second.

(5) Guide the cylinder so that it moves without significant lateral or rotational movement.

[42 FR 7152, Feb. 7, 1977]

49 CFR Ch. V (10-1-10 Edition)

§572.10 Limbs.

(a) The limbs consist of the assemblies shown as numbers SA 150 M070, SA 150 M071, SA 150 M080, and SA 150 M081 in Figure 1 and conform to the drawings subtended by these numbers.

(b) When each knee is impacted at 6.9 ft/sec. in accordance with paragraph (c) of this section, the maximum force on the femur shall be not more than 2500 pounds and not less than 1850 pounds, with a duration above 1000 pounds of not less than 1.7 milliseconds.

(c) Test procedure: (1) Seat the dummy without back support on a surface as specified in §572.11(i) that is 17.3 ±0.2 inches above a horizontal surface, oriented as specified in §572.11(i), and with the hip joint adjustment at any setting between 1g and 2g. Place the dummy legs in planes parallel to its midsagittal plane (knee pivot centerline perpendicular to the midsagittal plane) and with the feet flat on the horizontal surface. Adjust the feet and lower legs until the lines between the midpoints of the knee pivots and the ankle pivots are at any angle not less than 2 degrees and not more than 4 degrees rear of the vertical, measured at the centerline of the knee pivots.

(2) Reposition the dummy if necessary so that the rearmost point of the lower legs at the level one inch below the seating surface remains at any distance not less than 5 inches and not more than 6 inches forward of the forward edge of the seat.

(3) Align the test probe specified in §572.11(a) so that at impact its longitudinal centerline coincides within ±2° with the longitudinal centerline of the femur.

(4) Impact the knee with the test probe moving horizontally and parallel to the midsagittal plane at the specified velocity.

(5) Guide the probe during impact so that it moves with no significant lateral, vertical, or rotational movement.

[38 FR 20451, Aug. 1, 1973, as amended at 42 FR 7153, Feb. 7, 1977]

§572.11 Test conditions and instrumentation.

(a) The test probe used for thoracic and knee impact tests is a cylinder 6 inches in diameter that weighs 51.5

pounds including instrumentation. Its impacting end has a flat right face that is rigid and that has an edge radius of 0.5 inches.

(b) Accelerometers are mounted in the head on the horizontal transverse bulkhead shown in the drawings subreferenced under assembly No. SA 150 M010 in Figure 1, so that their sensitive axes intersect at a point in the midsagittal plane 0.5 inches above the horizontal bulkhead and 1.9 inches ventral of the vertical mating surface of the skull with the skull cover. One accelerometer is aligned with its sensitive axis perpendicular to the horizontal bulkhead in the midsagittal plane and with its seismic mass center at any distance up to 0.3 inches superior to the axial intersection point. Another accelerometer is aligned with its sensitive axis parallel to the horizontal bulkhead and perpendicular to the midsagittal plane, and with its seismic mass center at any distance up to 1.3 inches to the left of the axial intersection point (left side of dummy is the same as that of man). A third accelerometer is aligned with its sensitive axis parallel to the horizontal bulkhead in the midsagittal plane, and with its seismic mass center at any distance up to 1.3 inches dorsal to the axial intersection point.

(c) Accelerometers are mounted in the thorax by means of a bracket attached to the rear vertical surface (hereafter "attachment surface") of the thoracic spine so that their sensitive axes intersect at a point in the midsagittal plane 0.8 inches below the upper surface of the plate to which the neck mounting bracket is attached and 3.2 inches perpendicularly forward of the surface to which the accelerometer bracket is attached. One accelerometer has its sensitive axis oriented parallel to the attachment surface in the midsagittal plane, with its seismic mass center at any distance up to 1.3 inches inferior to the intersection of the sensitive axes specified above. Another accelerometer has its sensitive axis oriented parallel to the attachment surface and perpendicular to the midsagittal plane, with its seismic mass center at any distance up to 0.2 inches to the right of the intersection of the sensitive axes specified above. A

third accelerometer has its sensitive axis oriented perpendicular to the attachment surface in the midsagittal plane, with its seismic mass center at any distance up to 1.3 inches dorsal to the intersection of the sensitive axes specified above. Accelerometers are oriented with the dummy in the position specified in § 572.11(i).

(d) A force-sensing device is mounted axially in each femur shaft so that the transverse centerline of the sensing element is 4.25 inches from the knee's center of rotation.

(e) The outputs of acceleration and force-sensing devices installed in the dummy and in the test apparatus specified by this part are recorded in individual data channels that conform to the requirements of SAE Recommended Practice J211a, December 1971, with channel classes as follows:

- (1) Head acceleration—Class 1000.
- (2) Pendulum acceleration—Class 60.
- (3) Thorax acceleration—Class 180.
- (4) Thorax compression—Class 180.
- (5) Femur force—Class 600.

(f) The mountings for sensing devices have no resonance frequency within a range of 3 times the frequency range of the applicable channel class.

(g) Limb joints are set at 1g, barely restraining the weight of the limb when it is extended horizontally. The force required to move a limb segment does not exceed 2g throughout the range of limb motion.

(h) Performance tests are conducted at any temperature from 66 °F to 78 °F and at any relative humidity from 10 percent to 70 percent after exposure of the dummy to these conditions for a period of not less than 4 hours.

(i) For the performance tests specified in §§ 572.8, 572.9, and 572.10, the dummy is positioned in accordance with Figure 11 as follows:

(1) The dummy is placed on a flat, rigid, smooth, clean, dry, horizontal, steel test surface whose length and width dimensions are not less than 16 inches, so that the dummy's midsagittal plane is vertical and centered on the test surface and the rear-most points on its lower legs at the level of the test surface are at any distance not less than 5 inches and not more than 6 inches forward of the forward edge of the test surface.

§ 572.11

(2) The pelvis is adjusted so that the upper surface of the lumbar-pelvic adapter is horizontal.

(3) The shoulder yokes are adjusted so that they are at the midpoint of their anterior-posterior travel with their upper surfaces horizontal.

(4) The dummy is adjusted so that the rear surfaces of the shoulders and buttocks are tangent to a transverse vertical plane.

(5) The upper legs are positioned symmetrically about the midsagittal plane so that the distance between the knee pivot bolt heads is 11.6 inches.

(6) The lower legs are positioned in planes parallel to the midsagittal plane so that the lines between the midpoint of the knee pivots and the ankle pivots are vertical.

(j) The dummy's dimensions, as specified in drawing number SA 150 M002, are determined as follows:

(1) With the dummy seated as specified in paragraph (i) of this section, the head is adjusted and secured so that its occiput is 1.7 inches forward of the transverse vertical plane with the vertical mating surface of the skull with its cover parallel to the transverse vertical plane.

(2) The thorax is adjusted and secured so that the rear surface of the chest accelerometer mounting cavity is inclined 3° forward of vertical.

(3) Chest and waist circumference and chest depth measurements are taken with the dummy positioned in

49 CFR Ch. V (10-1-10 Edition)

accordance with paragraphs (j) (1) and (2) of this section.

(4) The chest skin and abdominal sac are removed and all following measurements are made without them.

(5) Seated height is measured from the seating surface to the uppermost point on the head-skin surface.

(6) Shoulder pivot height is measured from the seating surface to the center of the arm elevation pivot.

(7) H-point locations are measured from the seating surface to the center of the holes in the pelvis flesh covering in line with the hip motion ball.

(8) Knee pivot distance from the backline is measured to the center of the knee pivot bolt head.

(9) Knee pivot distance from floor is measured from the center of the knee pivot bolt head to the bottom of the heel when the foot is horizontal and pointing forward.

(10) Shoulder width measurement is taken at arm elevation pivot center height with the centerlines between the elbow pivots and the shoulder pivots vertical.

(11) Hip width measurement is taken at widest point of pelvic section.

(k) Performance tests of the same component, segment, assembly, or fully assembled dummy are separated in time by a period of not less than 30 minutes unless otherwise noted.

(1) Surfaces of dummy components are not painted except as specified in this part or in drawings subtended by this part.

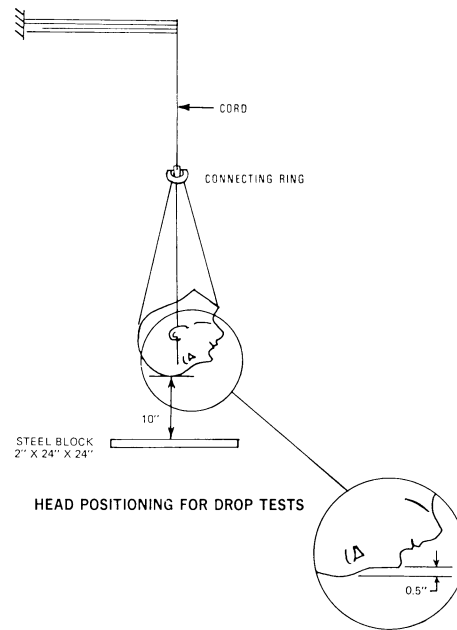
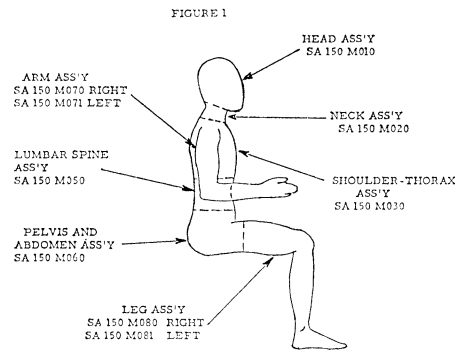


Figure 2

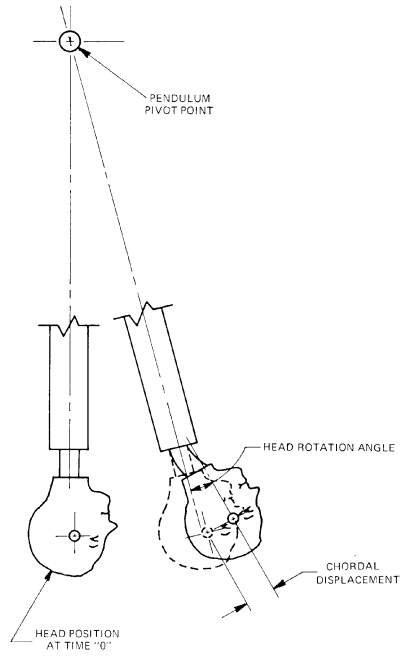


FIGURE NO. 3
NECK COMPONENT TEST

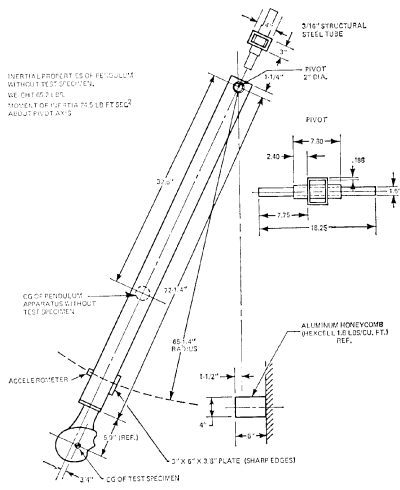


FIGURE NO. 5
LUMBAR FLEXION TEST

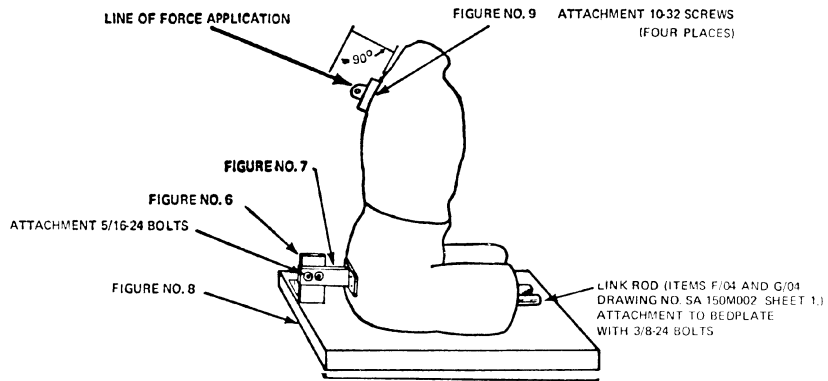


FIGURE NO. 6
SUPPORT BRACKET
LUMBAR TEST FIXTURE

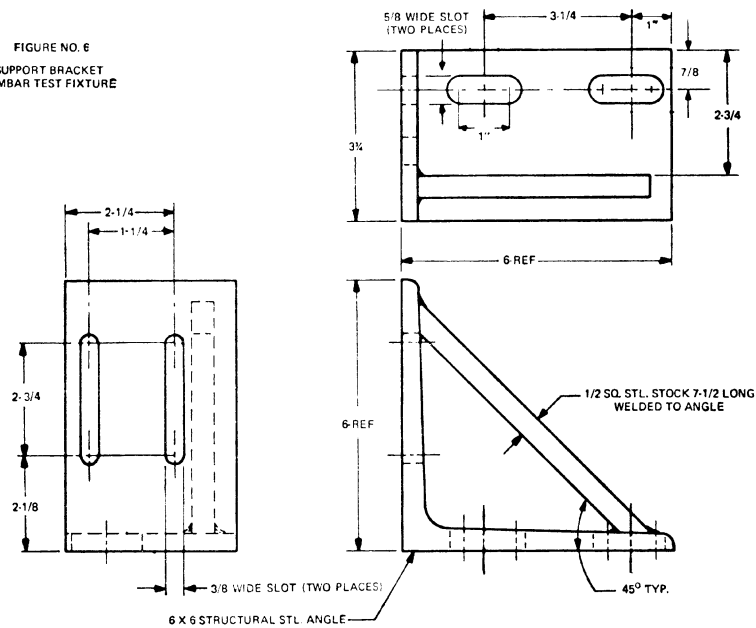
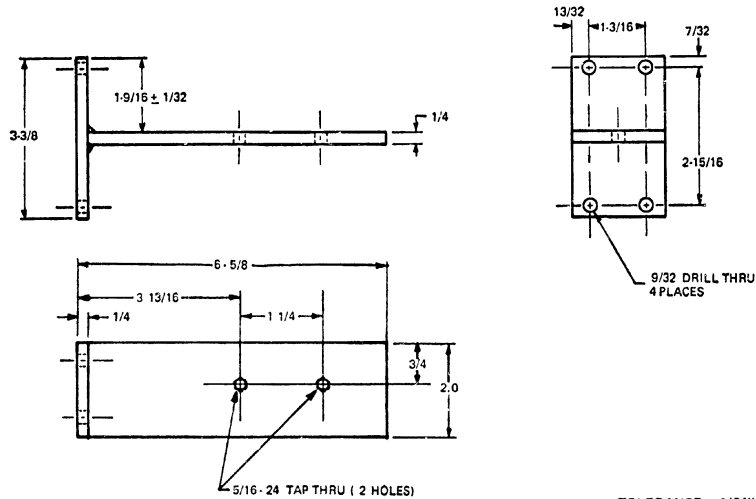
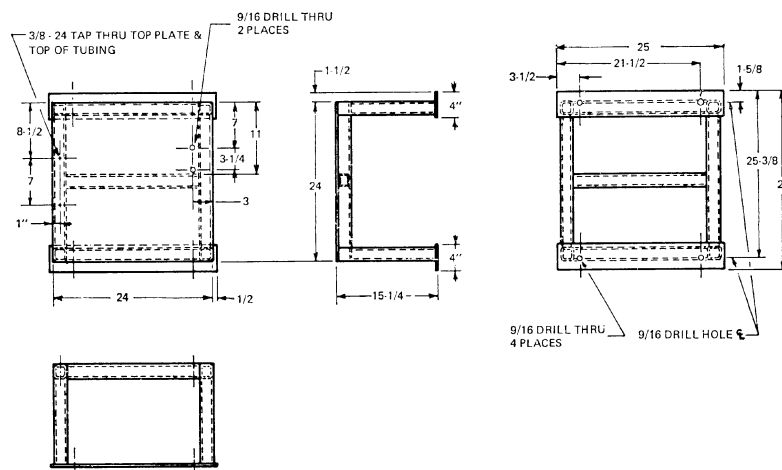


FIGURE NO. 7
MOUNTING BRACKET-LUMBAR TEST FIXTURE



TOLERANCE ± 1/64"
MATERIAL: STEEL
WELDED CONSTRUCTION

FIGURE NO. 8
BEDPLATE - LUMBAR TEST FIXTURE



MATL: STEEL - 1/4 THICK PLATE & 2 X 2-1/4 WALL SQ. TUBING
WELDED CONSTRUCTION

TOLERANCE: ± 1/32"

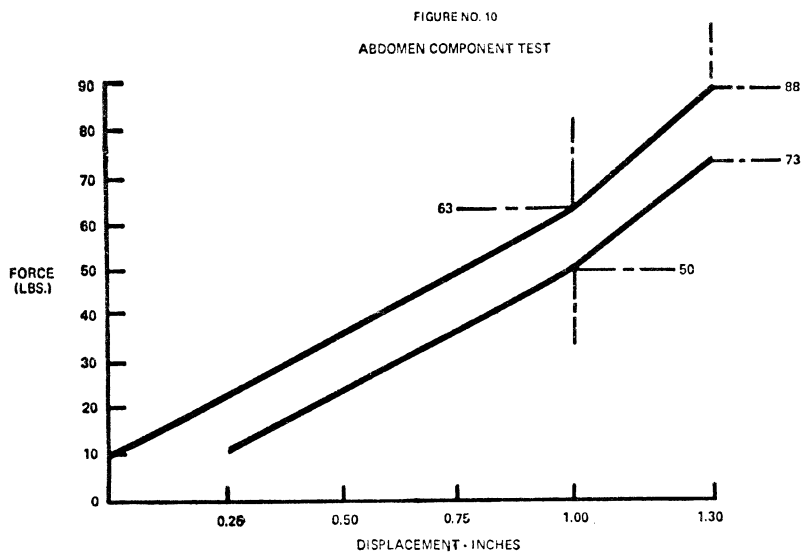
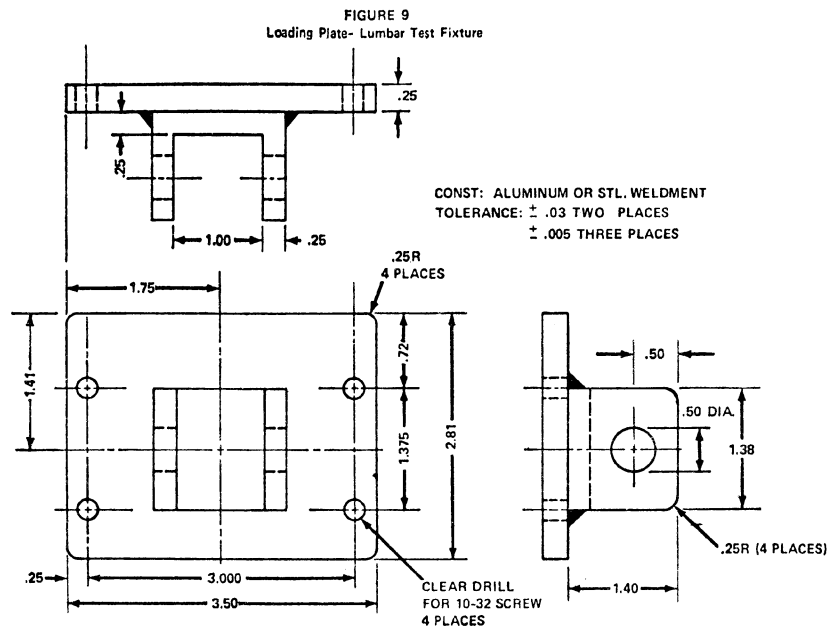
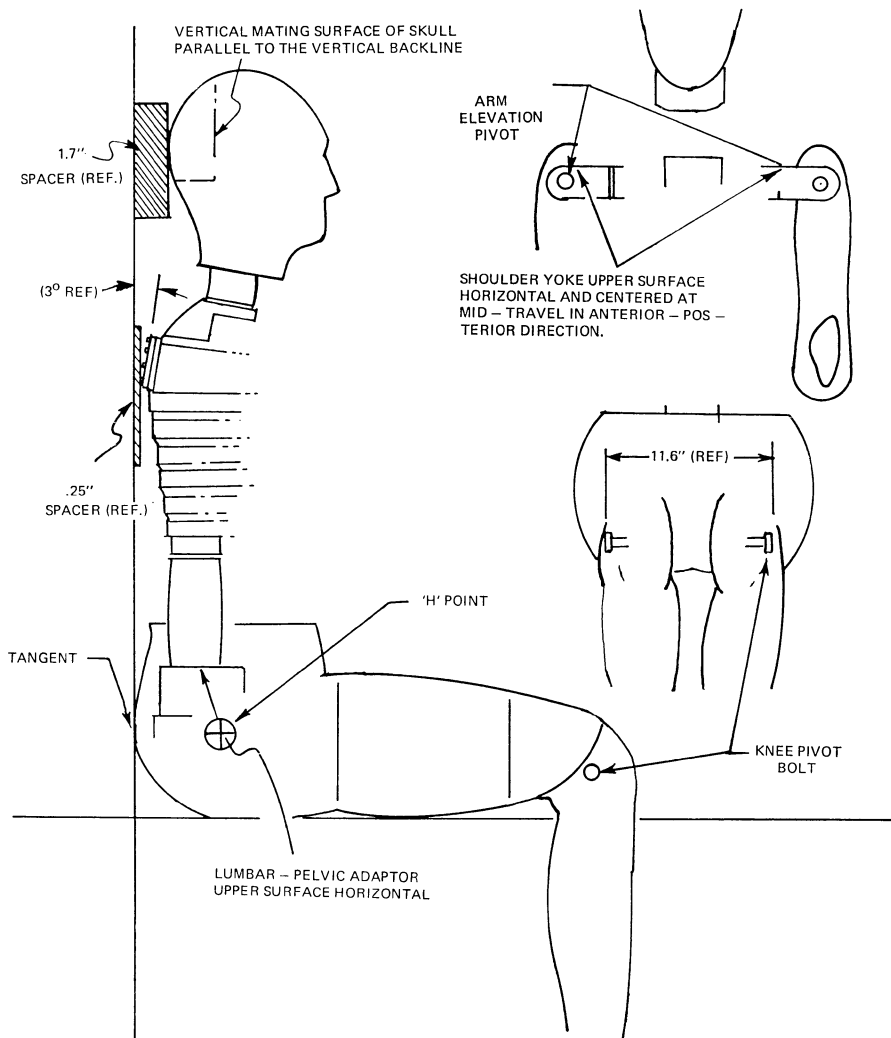


FIGURE No. 11

UPRIGHT SEATED POSITION FOR LINEAR MEASUREMENTS



[38 FR 20451, Aug. 1, 1973, as amended at 42 FR 7153, Feb. 7, 1977]

Subpart C—3-Year-Old Child

§ 572.15 General description.

SOURCE: 44 FR 76530, Dec. 27, 1979, unless otherwise noted.

(a) The dummy consists of the component assemblies specified in drawing SA 103C 001, which are described in their entirety by means of approximately 122 drawings and specifications

and an Operation and Maintenance Manual, dated May 28, 1976. The drawings and specifications are grouped by component assemblies under the following thirteen headings:

SA 103C 010 Head Assembly
 SA 103C 020 Neck Assembly
 SA 103C 030 Torso Assembly
 SA 103C 041 Upper Arm Assembly Left
 SA 103C 042 Upper Arm Assembly Right
 SA 103C 051 Forearm Hand Assembly Left
 SA 103C 052 Forearm Hand Assembly Right
 SA 103C 061 Upper Leg Assembly Left
 SA 103C 062 Upper Leg Assembly Right
 SA 103C 071 Lower Leg Assembly Left
 SA 103C 072 Lower Leg Assembly Right
 SA 103C 081 Foot Assembly left
 SA 103C 082 Foot Assembly Right.

(b) The drawings, specifications, and operation and maintenance manual referred to in this regulation that are not set forth in full are hereby incorporated in this part by reference. These materials are thereby made part of this regulation. The Director of the Federal Register has approved the materials incorporated by reference. For materials subject to change, only the specific version approved by the Director of the Federal Register and specified in the regulation are incorporated. A notice of any change will be published in the FEDERAL REGISTER. As a convenience to the reader, the materials incorporated by reference are listed in the Finding Aid Table found at the end of this volume of the Code of Federal Regulations.

(c) The materials incorporated by reference are available for examination in Docket 78-09, Room 5109, Docket Section, National Highway Traffic Safety Administration, 400 Seventh Street SW., Washington, DC 20590. Copies may be obtained from Rowley-Scher Reprographics, Inc., 1216 K Street NW., Washington, DC 20005 ((202) 628-6667). The materials are also on file in the reference library of the Office of the Federal Register, National Archives and Records Administration, Washington, DC.

(d) Adjacent segments are joined in a manner such that throughout the range of motion and also under simulated crash-impact conditions there is no contact between metallic elements except for contacts that exist under static conditions.

(e) The structural properties of the dummy are such that the dummy conforms to this part in every respect both before and after being used in vehicle tests specified in Standard No. 213 of this chapter (§ 571.213).

(f) The patterns of all cast and molded parts for reproduction of the molds needed in manufacturing of the dummies can be obtained on a loan basis by manufacturers of the testes dummies, or others if need is shown, from: Office of Vehicle Safety Standards, National Highway Traffic Safety Administration, 400 Seventh Street SW., Washington, DC 20590.

[50 FR 25423, June 19, 1985]

§ 572.16 Head.

(a) The head consists of the assembly designated as SA 103C 010 on drawing No. SA 103C 001, and conforms to either—

(1) Each item specified on drawing SA 103C 002(B), sheet 8; or

(2) Each item specified on drawing SA 103C 002, sheet 8.

(b) When the head is impacted by a test probe specified in § 572.21(a)(1) at 7 fps, then the peak resultant acceleration measured at the location of the accelerometer mounted in the headform according to § 572.21(b) is not less than 95g and not more than 118g.

(1) The recorded acceleration-time curve for this test is unimodal at or above the 50g level, and lies at or above that level for intervals:

(i) In the case of the head assembly specified in paragraph (a)(1) of this section, not less than 1.3 milliseconds and not more than 2.0 milliseconds;

(ii) In the case of the head assembly specified in paragraph (a)(2) of this section, not less than 2.0 milliseconds and not more than 3.0 milliseconds.

(2) The lateral acceleration vector does not exceed 7g.

(c) *Test procedure.* (1) Seat the dummy on a seating surface having a back support as specified in § 572.21(h) and orient the dummy in accordance with § 572.21(h) and adjust the joints of the limbs at any setting between 1g and 2g, which just supports the limbs' weight when the limbs are extended horizontally forward.

§572.17

(2) Adjust the test probe so that its longitudinal centerline is at the forehead at the point of orthogonal intersection of the head midsagittal plane and the transverse plane which is perpendicular to the "Z" axis of the head (longitudinal centerline of the skull anchor) and is located 0.6 ±0.1 inches above the centers of the head center of gravity reference pins and coincides within 2 degrees with the line made by the intersection of horizontal and midsagittal planes passing through this point.

(3) Adjust the dummy so that the surface area on the forehead immediately adjacent to the projected longitudinal centerline of the test probe is vertical.

(4) Impact the head with the test probe so that at the moment of impact the probe's longitudinal centerline falls within 2 degrees of a horizontal line in the dummy's midsagittal plane.

(5) Guide the probe during impact so that it moves with no significant lateral, vertical, or rotational movement.

(6) Allow a time period of at least 20 minutes between successive tests of the head.

[44 FR 76530, Dec. 27, 1979; 45 FR 43353, June 26, 1980, as amended at 45 FR 82267, Dec. 15, 1980; 55 FR 30468, July 26, 1990]

§572.17 Neck.

(a)(1) The neck for use with the head assembly described in §572.16(a)(1) consists of the assembly designated as SA 103C 020 on drawing No. SA 103C 001, conforms to each item specified on drawing No. SA 103C 002(B), sheet 9.

(2) The neck for use with the head assembly described in §572.16(a)(2) consists of the assembly designated as SA 103C 020 on drawing No. SA 103C 001, and conforms to each item specified on drawing No. SA 103C 002, sheet 9.

(b) When the head-neck assembly is tested in accordance with paragraph (c) of this section, the head shall rotate in reference to the pendulum's longitudinal centerline a total of 84 degrees ±8 degrees about its center of gravity, rotating to the extent specified in the following table at each indicated point in time, measured from impact, with the chordal displacement measured at its center of gravity. The chordal displacement at time T is defined as the straight line distance between (1) the

49 CFR Ch. V (10-1-10 Edition)

position relative to the pendulum arm of the head center of gravity at time zero, and (2) the position relative to the pendulum arm of the head center of gravity at time T as illustrated by figure 3. The peak resultant acceleration recorded at the location of the accelerometers mounted in the headform in accordance with §572.21(b) shall not exceed 30g. The pendulum shall not reverse direction until the head's center of gravity returns to the original zero time position relative to the pendulum arm.

Rotation (degrees)	Time (ms) ±(2+.08T)	Chordal displacement (inches ±0.8)
0	0	0
30	21	2.2
60	36	4.3
Maximum	62	5.8
60	91	4.3
30	108	2.2
0	123	0

(c) *Test procedure.* (1) Mount the head and neck on a rigid pendulum as specified in Figure 4, so that the head's midsagittal plane is vertical and coincides with the plane of motion of the pendulum's longitudinal centerline. Mount the neck directly to the pendulum as shown in Figure 15.

(2) Release the pendulum and allow it to fall freely from a height such that the velocity at impact is 17.00 ±1.0 feet per second (fps), measured at the center of the accelerometer specified in figure 4.

(3) Decelerate the pendulum to a stop with an acceleration-time pulse described as follows:

(i) Establish 5g and 20g levels on the a-t curve.

(ii) Establish t_1 at the point where the a-t curve first crosses the 5g level, t_2 at the point where the rising a-t curve first crosses the 20g level, t_3 at the point where the decaying a-t curve last crosses the 20g level, and t_4 at the point where the decaying a-t curve first crosses the 5g level.

(iii) t_2-t_1 , shall be not more than 4 milliseconds.

(iv) t_3-t_2 , shall be not less than 18 and not more than 21 milliseconds.

(v) t_4-t_3 , shall be not more than 5 milliseconds.

(vi) The average deceleration between t_2 and t_3 shall be not less than 20g and not more than 34g.

(4) Allow the neck to flex without contact of the head or neck with any object other than the pendulum arm.

(5) Allow a time period of at least 1 hour between successive tests of the head and neck.

[44 FR 76530, Dec. 27, 1979; 45 FR 43353, June 26, 1980, as amended at 55 FR 30468, July 26, 1990]

§ 572.18 Thorax.

(a) The thorax consists of the part of the torso shown in assembly drawing SA 103C 001 by number SA 103C 030 and conforms to each of the applicable drawings listed under this number on drawing SA 103C 002, sheets 10 and 11.

(b) When impacted by a test probe conforming to § 572.21(a) at 13 fps in accordance with paragraph (c) of this section, the peak resultant accelerations at the location of the accelerometers mounted in the chest cavity in accordance with § 572.21(c) shall be not less than 50g and not more than 70g. The acceleration-time curve for the test shall be unimodal at or above the 30g level and shall lie at or above the 30g level for an interval not less than 2.5 milliseconds and not more than 4.0 milliseconds. The lateral acceleration shall not exceed 5g.

(c) *Test procedure.* (1) With the dummy seated without back support on a surface as specified in § 572.21(h) and oriented as specified in § 572.21(h), adjust the dummy arms and legs until they are extended horizontally forward parallel to the midsagittal plane. The joints of the limbs are adjusted at any setting between 1g and 2g, which just supports the limbs' weight when the limbs are extended horizontally forward.

(2) Establish the impact point at the chest midsagittal plane so that it is 1.5 inches below the longitudinal centerline of the bolt that attaches the top of the ribcage sternum to the thoracic spine box.

(3) Adjust the dummy so that the tangent plane at the surface on the thorax immediately adjacent to the designated impact point is vertical and parallel to the face of the test probe.

(4) Place the longitudinal centerline of the test probe to coincide with the designated impact point and align the test probe so that at impact its longitudinal centerline coincides within 2 degrees with the line formed by intersection of the horizontal and midsagittal planes passing through the designated impact point.

(5) Impact the thorax with the test probe so that at the moment of impact the probe's longitudinal centerline falls within 2 degrees of a horizontal line in the dummy midsagittal plane.

(6) Guide the probe during impact so that it moves with no significant lateral, vertical or rotational movement.

(7) Allow a time period of at least 20 minutes between successive tests of the chest.

§ 572.19 Lumbar spine, abdomen and pelvis.

(a) The lumbar spine, abdomen, and pelvis consist of the part of the torso assembly shown by number SA 103C 030 on drawing SA 103C 001 and conform to each of the applicable drawings listed under this number on drawing SA 103C 002, sheets 10 and 11.

(b) When subjected to continuously applied force in accordance with paragraph (c) of this section, the lumbar spine assembly shall flex by an amount that permits the rigid thoracic spine to rotate from its initial position in accordance with Figure 18 of this subpart by 40 degrees at a force level of not less than 34 pounds and not more than 47 pounds, and straighten upon removal of the force to within 5 degrees of its initial position.

(c) *Test procedure.* (1) The dummy with lower legs removed is positioned in an upright seated position on a seat as indicated in Figure 18, ensuring that all dummy component surfaces are clean, dry and untreated unless otherwise specified.

(2) Attach the pelvis to the seating surface by a bolt C/328, modified as shown in Figure 18, and the upper legs at the knee axial rotation joints by the attachments shown in Figure 18. Tighten the mountings so that the pelvis-lumbar joining surface is horizontal and adjust the femur ball-flange screws at each hip socket joint to 50 inch pounds torque. Remove the head and

§ 572.20

the neck and install a cylindrical aluminum adapter 2.0 inches in diameter and 2.80 inches long in place of the neck.

(3) Flex the thorax forward 50 degrees and then rearward as necessary to return to its initial position in accordance with Figure 18 unsupported by external means.

(4) Apply a forward pull force in the midsagittal plane at the top of the neck adapter, so that at 40 degrees of the lumbar spine flexion the applied force is perpendicular to the thoracic spine box. Apply the force at any torso deflection rate between 0.5 and 1.5 degrees per second up to 40 degrees of flexion but no further; continue to apply for 10 seconds the force necessary to maintain 40 degrees of flexion, and record the highest applied force at that time. Release all force as rapidly as possible and measure the return angle 3 minutes after the release.

§ 572.20 Limbs.

The limbs consist of the assemblies shown on drawing SA 103C 001 as Nos. SA 103C 041, SA 103C 042, SA 103C 051, SA 103C 052, SA 103C 061, SA 103C 062, SA 103C 071, SA 103C 072, SA 103C 081, SA 103C 082, and conform to each of the applicable drawings listed under their respective numbers of the drawing SA 103C 002, sheets 12 through 21.

§ 572.21 Test conditions and instrumentation.

(a)(1) The test probe used for head and thoracic impact tests is a cylinder 3 inches in diameter, 13.8 inches long, and weighing 10 lbs., 6 ozs. Its impacting end has a flat right face that is rigid and that has an edge radius of 0.5 inches.

(2) The head and thorax assembly may be instrumented with a Type A or Type C accelerometer.

(i) Type A accelerometer is defined in drawing SA-572 S1.

(ii) Type C accelerometer is defined in drawing SA-572 S2.

(b) *Head accelerometers.* Install one of the triaxial accelerometers specified in § 572.21(a)(2) on a mounting block located on the horizontal transverse bulkhead as shown in the drawings sub-referenced under assembly SA 103C 010 so that the seismic mass centers of

49 CFR Ch. V (10-1-10 Edition)

each sensing element are positioned as specified in this paragraph, relative to the head accelerometer reference point located at the intersection of a line connecting the longitudinal centerlines of the transfer pins in the side of the dummy head with the midsagittal plane of the dummy head.

(1) The sensing elements of the Type C triaxial accelerometer are aligned as follows:

(i) Align one sensitive axis parallel to the vertical bulkhead and coincident with the midsagittal plane, with the seismic mass center located 0.2 inches dorsal to, and 0.1 inches inferior to the head accelerometer reference point.

(ii) Align the second sensitive axis with the horizontal plane, perpendicular to the midsagittal plane, with the seismic mass center located 0.1 inches inferior, 0.4 inches to the right of, and 0.9 inches dorsal to the head accelerometer reference point.

(iii) Align the third sensitive axis so that it is parallel to the midsagittal and horizontal planes, with the seismic mass center located 0.1 inches inferior to, 0.6 inches dorsal to, and 0.4 inches to the right of the head accelerometer reference point.

(iv) All seismic mass centers are positioned with ± 0.05 inches of the specified locations.

(2) The sensing elements of the Type A triaxial accelerometer are aligned as follows:

(i) Align one sensitive axis parallel to the vertical bulkhead and coincident with midsagittal planes, with the seismic mass center located from 0.2 to 0.47 inches dorsal to, from 0.01 inches inferior to 0.21 inches superior, and from 0.0 to 0.17 inches left of the head accelerometer reference point.

(ii) Align the second sensitive axis with the horizontal plane, perpendicular to the midsagittal plane, with the seismic mass center located 0.1 to 0.13 inches inferior to, 0.17 to 0.4 inches to the right of, and 0.47 to 0.9 inches dorsal of the head accelerometer reference point.

(iii) Align the third sensitive axis so that it is parallel to the midsagittal and horizontal planes, with the seismic mass center located 0.1 to 0.13 inches inferior to, 0.6 to 0.81 inches dorsal to, and from 0.17 inches left to 0.4 inches

right of the head accelerometer reference point.

(c) *Thorax accelerometers.* Install one of the triaxial accelerometers specified in § 572.21(a)(2) on a mounting plate attached to the vertical transverse bulkhead shown in the drawing subreferenced under assembly No. SA 103C 030 in drawing SA 103C 001, so that the seismic mass centers of each sensing element are positioned as specified in this paragraph, relative to the thorax accelerometer reference point located in the midsagittal plane 3 inches above the top surface of the lumbar spine, and 0.3 inches dorsal to the accelerometer mounting plate surface.

(1) The sensing elements of the Type C triaxial accelerometer are aligned as follows:

(i) Align one sensitive axis parallel to the vertical bulkhead and midsagittal planes, with the seismic mass center located 0.2 inches to the left of, 0.1 inches inferior to, and 0.2 inches ventral to the thorax accelerometer reference point.

(ii) Align the second sensitive axis so that it is in the horizontal transverse plane, and perpendicular to the midsagittal plane, with the seismic mass center located 0.2 inches to the right of, 0.1 inches inferior to, and 0.2 inches ventral to the thorax accelerometer reference point.

(iii) Align the third sensitive axis so that it is parallel to the midsagittal and horizontal planes, with the seismic mass center located 0.2 inches superior to, 0.5 inches to the right of, and 0.1 inches ventral to the thorax accelerometer reference points.

(iv) All seismic mass centers shall be positioned within ± 0.05 inches of the specified locations.

(2) The sensing elements of the Type A triaxial accelerometer are aligned as follows:

(i) Align one sensitive axis parallel to the vertical bulkhead and midsagittal planes, with the seismic mass center located from 0.2 inches left to 0.28 inches right, from 0.5 to 0.15 inches inferior to, and from 0.15 to 0.25 inches ventral of the thorax accelerometer reference point.

(ii) Align the second sensitive axis so that it is in the horizontal transverse plane and perpendicular to the

midsagittal plane, with the seismic mass center located from 0.06 inches left to 0.2 inches right of, from 0.1 inches inferior to 0.24 inches superior, and 0.15 to 0.25 inches ventral to the thorax accelerometer reference point.

(iii) Align the third sensitive axis so that it is parallel to the midsagittal and horizontal planes, with the seismic mass center located 0.15 to 0.25 inches superior to, 0.28 to 0.5 inches to the right of, and from 0.1 inches ventral to 0.19 inches dorsal to the thorax accelerometer reference point.

(d) The outputs of accelerometers installed in the dummy, and of test apparatus specified by this part, are recorded in individual data channels that conform to the requirements of SAE Recommended Practice J211a, December 1971, with channel classes as follows:

(1) Head acceleration—Class 1000.

(2) Pendulum acceleration—Class 60.

(3) Thorax acceleration—Class 180.

(e) The mountings for accelerometers have no resonance frequency less than cut-off 3 times the cut-off frequency of the applicable channel class.

(f) Limb joints are set at the force between 1-2g, which just supports the limbs' weight when the limbs are extended horizontally forward. The force required to move a limb segment does not exceed 2g throughout the range of limb motion.

(g) Performance tests are conducted at any temperature from 66 °F to 78 °F and at any relative humidity from 10 percent to 70 percent after exposure of the dummy to these conditions for a period of not less than 4 hours.

(h) For the performance tests specified in §§ 572.16, 572.18, and 572.19, the dummy is positioned in accordance with Figures 16, 17, and 18 as follows:

(1) The dummy is placed on a flat, rigid, clean, dry, horizontal surface of teflon sheeting with a smoothness of 40 microinches and whose length and width dimensions are not less than 16 inches, so that the dummy's midsagittal plane is vertical and centered on the test surface. For head tests, the seat has a vertical back support whose top is 12.4 ± 0.2 inches above the seating surface. The rear surfaces of the dummy's shoulders and buttocks are touching the back support as

§ 572.21

49 CFR Ch. V (10-1-10 Edition)

shown in Figure 16. For thorax and lumbar spine tests, the seating surface is without the back support as shown in Figures 17 and 18, respectively.

(2) The shoulder yokes are adjusted so that they are at the midpoint of their anterior-posterior travel with their upper surfaces horizontal.

(3) The dummy is adjusted for head impact and lumbar flexion tests so that the rear surfaces of the shoulders and buttocks are tangent to a transverse vertical plane.

(4) The arms and legs are positioned so that their centerlines are in planes parallel to the midsagittal plane.

(i) The dummy's dimensions are specified in drawings No. SA 103C 002, sheets 22 through 26.

(j) Performance tests of the same component, segment, assembly or fully assembled dummy are separated in time by a period of not less than 20 minutes unless otherwise specified.

(k) Surfaces of the dummy components are not painted except as specified in this part or in drawings subtended by this part.

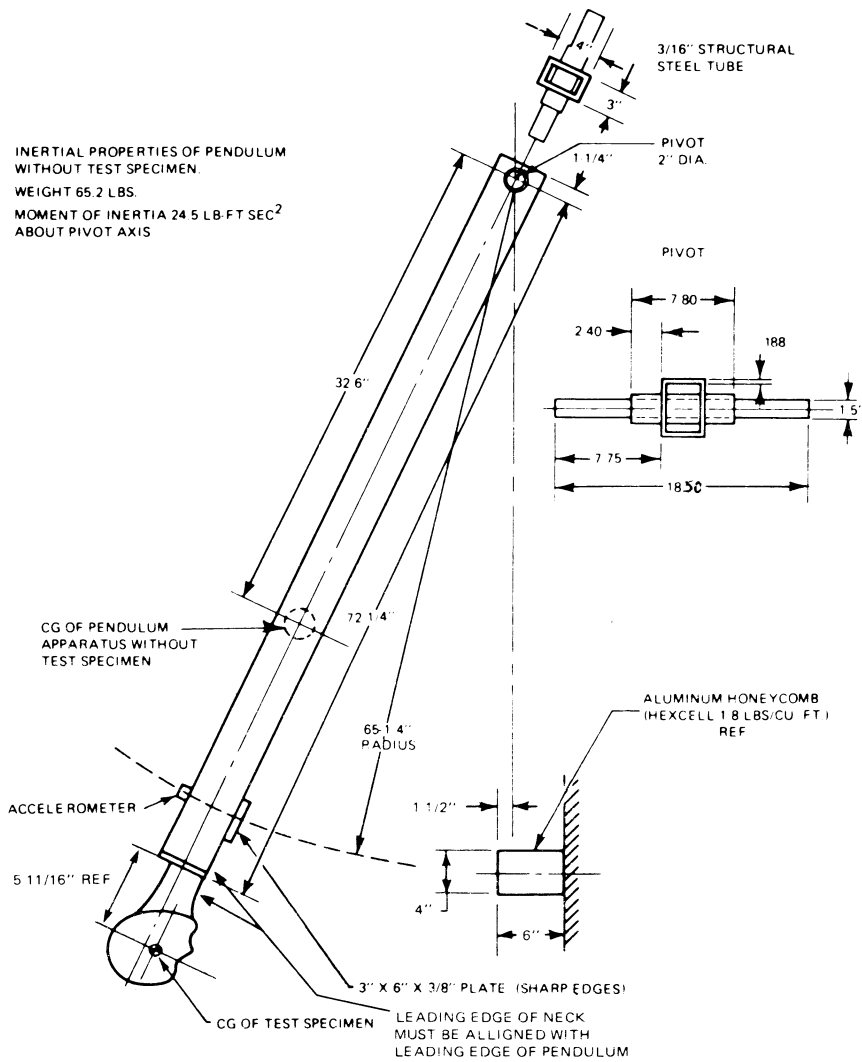


FIGURE NO. 15
 NECK COMPONENT TEST

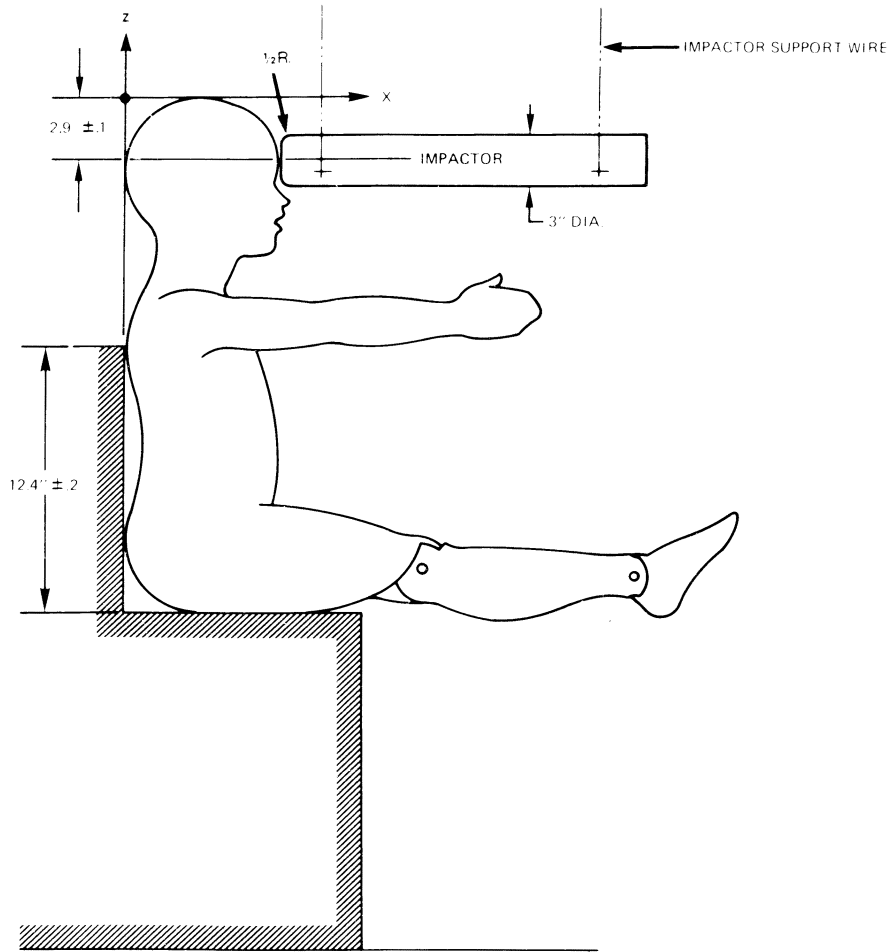


FIGURE NO. 16
HEAD IMPACT TEST

IMPACTOR FACE TO BE VERTICAL $\pm 2^\circ$
AT CONTACT OF CHEST

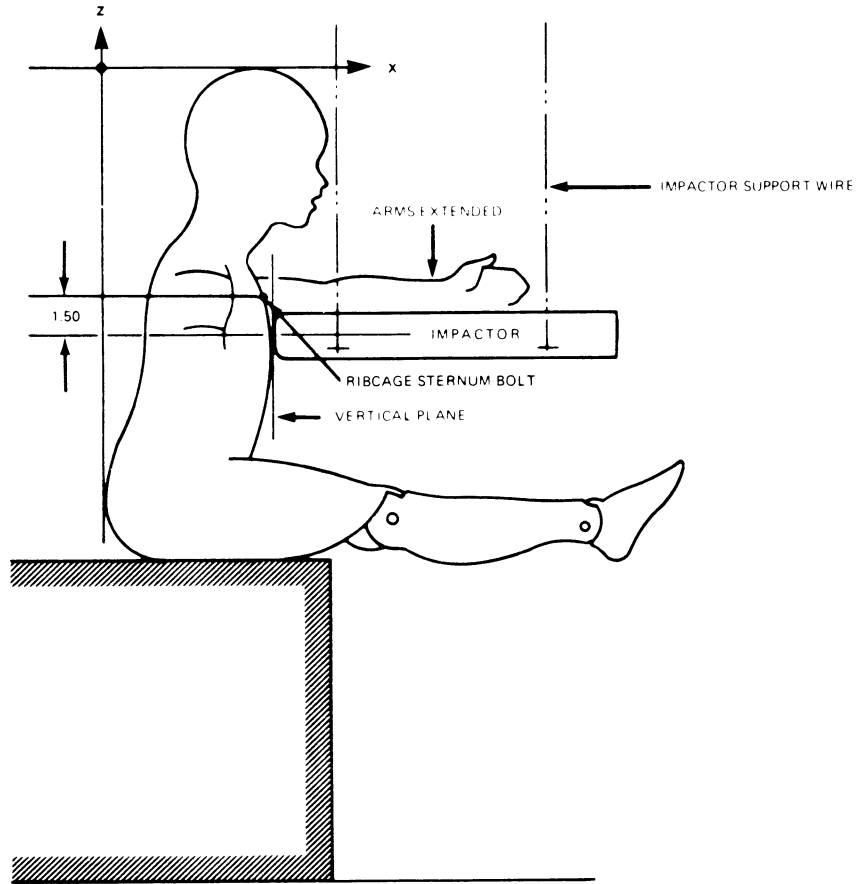


FIGURE NO. 17
CHEST IMPACT TEST

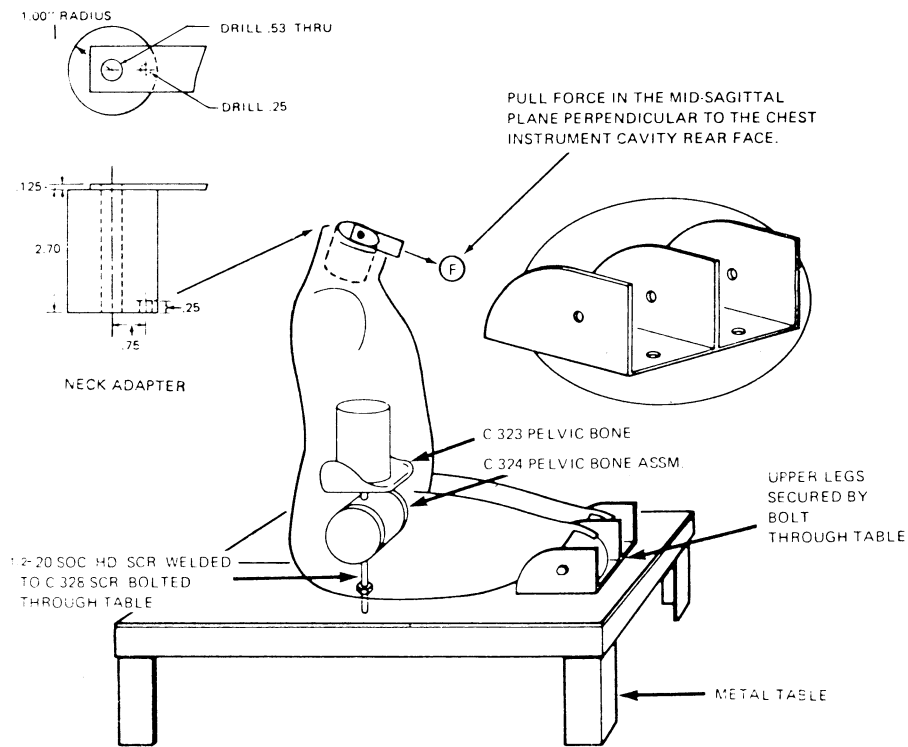


FIGURE NO. 18
LUMBAR SPINE FLEXION TEST

[44 FR 76530, Dec. 27, 1979, as amended at 45 FR 82267, Dec. 15, 1980; 55 FR 30468, July 26, 1990]

Subpart D—6-Month-Old Infant

§ 572.25 General description.

(a) The infant dummy is specified in its entirety by means of 5 drawings (No. SA 1001) and a construction manual, dated July 2, 1974, which describe in detail the materials and the proce-

dures involved in the manufacturing of this dummy.

(b) The drawings, specifications, and construction manual referred to in this regulation that are not set forth in full are hereby incorporated in this part by reference. These materials are thereby

made part of this regulation. The Director of the Federal Register has approved the materials incorporated by reference. For materials subject to change, only the specific version approved by the Director of the Federal Register and specified in the regulation are incorporated. A notice of any change will be published in the FEDERAL REGISTER. As a convenience to the reader, the materials incorporated by reference are listed in the Finding Aid Table found at the end of this volume of the Code of Federal Regulations.

(c) The materials incorporated by reference are available for examination in Docket 78-09, Room 5109, Docket Section, National Highway Traffic Safety Administration, 400 Seventh Street SW., Washington, DC, 20590. Copies may be obtained from Rowley-Scher Reprographics, Inc., 1216 K Street NW., Washington, DC 20005 ((202) 628-6667). The materials are also on file in the reference library of the Office of the Federal Register, National Archives and Records Administration, Washington, DC.

(d) The structural properties of the dummy are such that the dummy conforms to this part in every respect both before and after being used in vehicle tests specified in Standard No. 213 of this chapter (§ 571.213).

[50 FR 25424, June 19, 1985]

Subpart E—Hybrid III Test Dummy

SOURCE: 51 FR 26701, July 25, 1986, unless otherwise noted.

§ 572.30 Incorporated materials.

(a) The drawings and specifications referred to in this regulation that are not set forth in full are hereby incorporated in this part by reference. The Director of the Federal Register has approved the materials incorporated by reference. For materials subject to change, only the specific version approved by the Director of the Federal Register and specified in the regulation are incorporated. A notice of any change will be published in the FEDERAL REGISTER. As a convenience to the reader, the materials incorporated by reference are listed in the Finding

Aid Table found at the end of this volume of the Code of Federal Regulations.

(b) The materials incorporated by reference are available for examination in the general reference section of docket 74-14, Docket Section, National Highway Traffic Safety Administration, Room 5109, 400 Seventh Street, SW., Washington, DC 20590. Copies may be obtained from Reprographic Technologies, 9000 Virginia Manor Road, Beltsville, MD 20705, Telephone (301) 210-5600, Facsimile (301) 419-5069, Attn. Mr. Jay Wall. Drawings and specifications are also on file at the National Archives and Records Administration (NARA). For information on the availability of this material at NARA, call 202-741-6030, or go to: http://www.archives.gov/federal_register/code_of_federal_regulations/ibr_locations.html.

[51 FR 26701, July 25, 1986, as amended at 61 FR 67955, Dec. 26, 1996]

§ 572.31 General description.

(a) The Hybrid III 50th percentile size dummy consists of components and assemblies specified in the Anthropomorphic Test Dummy drawing and specifications package which consists of the following six items:

(1) The Anthropomorphic Test Dummy Parts List, dated June 26, 1998, and containing 16 pages, and a Parts List Index, dated June 26, 1998, containing 8 pages.

(2) A listing of Hybrid III Dummy Transducers-reference document AGARD-AR-330, "Anthropomorphic Dummies for Crash and Escape System Testing", Chapter 6, Table 6-2, North Atlantic Treaty Organization, July, 1996.

(3) A General Motors Drawing Package identified by GM Drawing No. 78051-218, revision U, titled "Hybrid III Anthropomorphic Test Dummy," dated August 30, 1998, the following component assemblies, and subordinate drawings:

Drawing No.	Revision
78051-61X head assembly-complete, (May 20, 1978)	(T)
78051-90 neck assembly-complete, dated May 20, 1978	(A)

§ 572.32

49 CFR Ch. V (10–1–10 Edition)

Drawing No.	Revision
78051–89 upper torso assembly-complete, dated May 20, 1978	(K)
78051–70 lower torso assembly-complete, dated June 30, 1998, except for drawing No. 78051–55, "Instrumentation Assembly-Pelvic Accelerometer," dated August 2, 1979	(F)
86–5001–001 leg assembly-complete (LH), dated March 26, 1996	(A)
86–5001–002 leg assembly-complete (RH), dated March 26, 1996	(A)
78051–123 arm assembly-complete (LH), dated May 20, 1996	(D)
78051–124 arm assembly-complete (RH), dated May 20, 1978	(D)
78051–59 pelvic assembly-complete, dated June 30, 1998	(G)
78051–60 pelvic structure-molded, dated June 30, 1998	(E)

test specified in Standard No. 208 of this chapter (§ 571.208).

[51 FR 26701, July 25, 1986, as amended at 53 FR 8764, Mar. 17, 1988; 57 FR 47010, Oct. 14, 1992; 61 FR 67955, Dec. 26, 1996; 62 FR 27514, May 20, 1997; 63 FR 5747, Feb. 4, 1998; 63 FR 53851, Oct. 7, 1998]

§ 572.32 Head.

(a) The head consists of the assembly shown in drawing 78051–61X, revision C, and conforms to each of the drawings subtended therein.

(b) When the head (Drawing number 78051–61X, titled "head assembly—complete," dated March 28, 1997 (Revision C) with six axis neck transducer structural replacement (Drawing number 78051–383X, Revision P, titled "Neck Transducer Structural Replacement," dated November 1, 1995) is dropped from a height of 14.8 inches in accordance with paragraph (c) of this section, the peak resultant accelerations at the location of the accelerometers mounted in the head in accordance with § 572.36(c) shall not be less than 225g, and not more than 275g. The acceleration/time curve for the test shall be unimodal to the extent that oscillations occurring after the main acceleration pulse are less than ten percent (zero to peak) of the main pulse. The lateral acceleration vector shall not exceed 15g (zero to peak).

(c) *Test procedure.* (1) Soak the head assembly in a test environment at any temperature between 66 degrees F to 78 degrees F and at a relative humidity from 10% to 70% for a period of at least four hours prior to its application in a test.

(2) Clean the head's skin surface and the surface of the impact plate with 1,1,1 Trichlorethane or equivalent.

(3) Suspend the head, as shown in Figure 19, so that the lowest point on the forehead is 0.5 inches below the lowest point on the dummy's nose when the midsagittal plane is vertical.

(4) Disassembly, Inspection, Assembly and Limbs Adjustment Procedures for the Hybrid III dummy, dated June 1998.

(5) Sign Convention for signal outputs—reference document SAE J1733 Information Report, titled "Sign Convention for Vehicle Crash Testing", dated 1994–12.

(6) Exterior dimensions of the Hybrid III dummy, dated July 15, 1986.

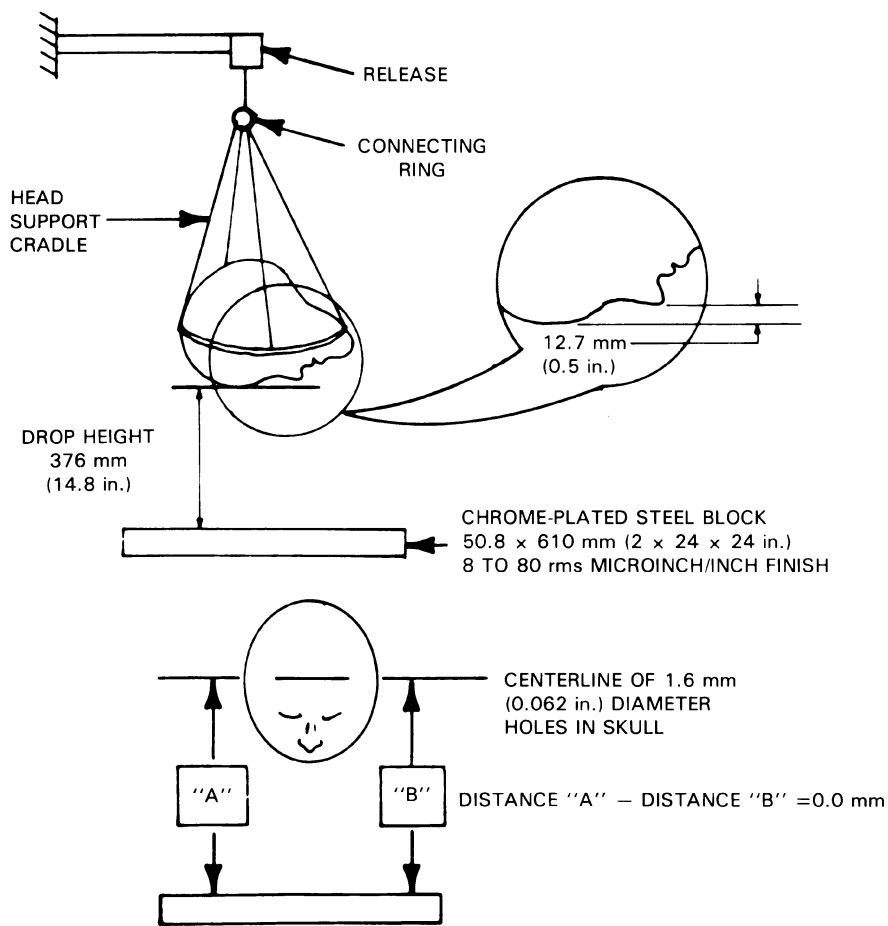
(b) [Reserved]

(c) Adjacent segments are joined in a manner such that throughout the range of motion and also under crash-impact conditions, there is no contact between metallic elements except for contacts that exist under static conditions.

(d) The weights, inertial properties and centers of gravity location of component assemblies shall conform to those listed in drawing 78051–338, revision S, titled "Segment Weights, Inertial Properties, Center of Gravity Location—Hybrid III," dated May 20, 1978 of drawing No. 78051–218.

(e) The structural properties of the dummy are such that the dummy conforms to this part in every respect both before and after being used in vehicle

FIGURE 19
TEST SET-UP SPECIFICATIONS



NOTE: TOLERANCE ON TEST SETUP DIMENSIONS ± 1 mm (0.04 in.)

(4) Drop the head from the specified height by means that ensure instant release into a rigidly supported flat horizontal steel plate, which is 2 inches thick and 2 feet square. The plate shall have a clean, dry surface and any microfinish of not less than 8 micro-

inches (rms) and not more than 80 microinches (rms).

(5) Allow at least 3 hours between successive tests on the same head.

[51 FR 26701, July 25, 1986, as amended at 62 FR 27514, May 20, 1997]

§ 572.33

49 CFR Ch. V (10–1–10 Edition)

§ 572.33 Neck.

(a) The neck consists of the assembly shown in drawing 78051–90, revision A and conforms to each of the drawings subtended therein.

(b) When the head and neck assembly (consisting of the parts 78051–61X, revision C; –90, revision A; –84; –94; –98; –104, revision F; –303, revision E; –305; –306; –307, revision X) which has a six axis neck transducer (Drawing number C–1709, Revision D, titled “Neck transducer,” dated February 1, 1993.) installed in conformance with § 572.36(d), is tested in accordance with paragraph (c) of this section, it shall have the following characteristics:

(1) *Flexion.* (i) Plane D, referenced in Figure 20, shall rotate between 64 degrees and 78 degrees, which shall occur between 57 milliseconds (ms) and 64 ms from time zero. In first rebound, the rotation of Plane D shall cross 0 degrees between 113 ms and 128 ms.

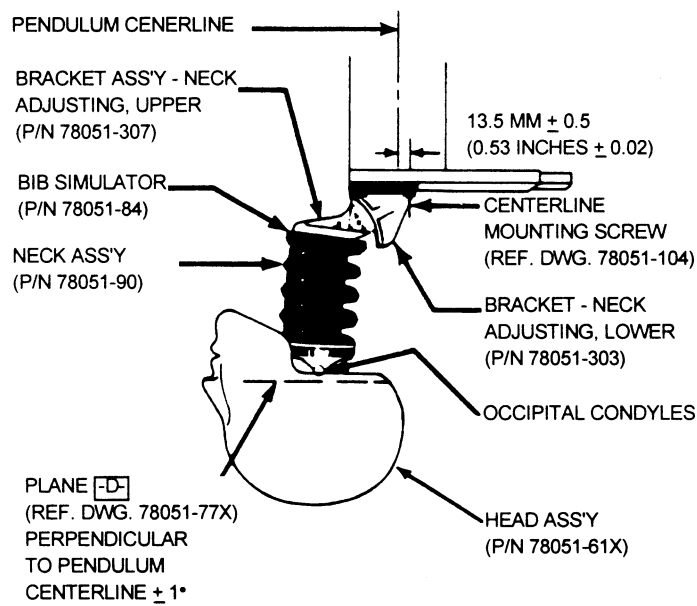
(ii) The moment measured by the six axis neck transducer (drawing C–1709, revision D) about the occipital condyles, referenced in Figure 20, shall be calculated by the following formula: $\text{Moment (lbs-ft)} = M_y - 0.058 \times F_x$, where M_y is the moment measured in lbs-ft by the “Y” axis moment sensor of the six axis neck transducer and F_x

is the force measured in lbs by the “X” axis force sensor (Channel Class 600) of the six axis neck transducer. The moment shall have a maximum value between 65 lbs-ft and 80 lbs-ft occurring between 47ms and 58 ms, and the positive moment shall decay for the first time to 0 lb-ft between 97 ms and 107 ms.

(2) *Extension.* (i) Plane D, referenced in Figure 21, shall rotate between 81 degrees and 106 degrees, which shall occur between 72 ms and 82 ms from time zero. In first rebound, rotation of Plane D shall cross 0 degrees between 147 ms and 174 ms.

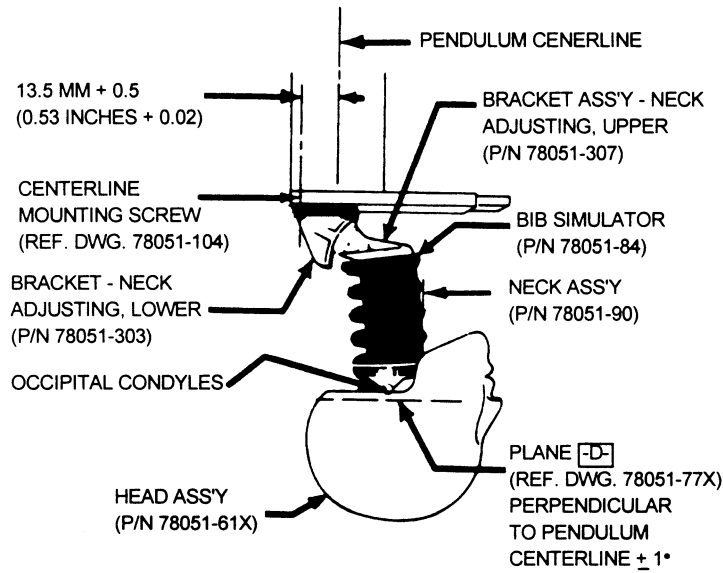
(ii) The moment measured by the six axis neck transducer (drawing C–1709, revision D) about the occipital condyles, referenced in Figure 21, shall be calculated by the following formula: $\text{Moment (lbs-ft)} = M_y - 0.058 \times F_x$, where M_y is the moment measured in lbs-ft by the “Y” axis moment sensor of the six axis neck transducer and F_x is the force measured in lbs by the “X” axis force sensor (Channel Class 600) of the six axis neck transducer. The moment shall have a maximum value between –39 lbs-ft and –59 lbs-ft, occurring between 65 ms and 79 ms, and the negative moment shall decay for the first time to 0 lb-ft between 120 ms and 148 ms.

FIGURE 20
FLEXION - TEST SET-UP SPECIFICATIONS



NOTE: PENDULUM SHOWN AT TIME ZERO POSITION

FIGURE 21
EXTENSION - TEST SET-UP SPECIFICATIONS



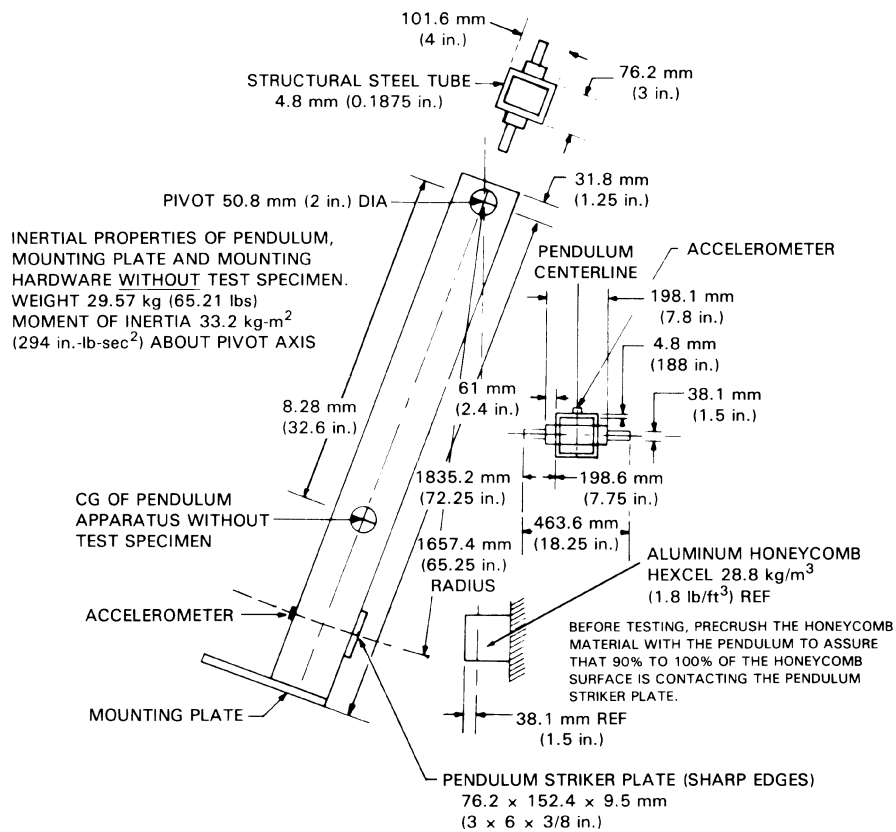
NOTE: PENDULUM SHOWN AT TIME ZERO POSITION

(c) *Test procedure.* (1) Soak the test material in a test environment at any temperature between 69 degrees F to 72 degrees F and at a relative humidity from 10% to 70% for a period of at least four hours prior to its application in a test.

(2) Torque the jamnut (78051-64) on the neck cable (78051-301, revision E) to 1.0 lbs-ft ±.2 lbs-ft.

(3) Mount the head-neck assembly, defined in paragraph (b) of this section, on a rigid pendulum as shown in Figure 22 so that the head's midsagittal plane is vertical and coincides with the plane of motion of the pendulum's longitudinal axis.

FIGURE 22
PENDULUM SPECIFICATIONS



(4) Release the pendulum and allow it to fall freely from a height such that the tangential velocity at the pendulum accelerometer centerline at the instance of contact with the honeycomb is 23.0 ft/sec ±0.4 ft/sec. for flexion testing and 19.9 ft/sec. ±0.4 ft/sec. for extension testing. The pendulum deceleration vs. time pulse for flexion testing shall conform to the characteristics shown in Table A and the decaying deceleration-time curve shall first

cross 5_g between 34 ms and 42 ms. The pendulum deceleration vs. time pulse for extension testing shall conform to the characteristics shown in Table B and the decaying deceleration-time curve shall cross 5_g between 38 ms and 46 ms.

§ 572.34

TABLE A—FLEXION PENDULUM DECELERATION VS. TIME PULSE

Time (ms)	Flexion de- celeration level (g)
10	22.50–27.50
20	17.60–22.60
30	12.50–18.50
Any other time above 30 ms	29 maximum.

TABLE B—EXTENSION PENDULUM DECELERATION VS. TIME PULSE

Time (ms)	Extension de- celeration level (g)
10	17.20–21.20
20	14.00–19.00
30	11.00–16.00
Any other time above 30 ms	22 maximum.

(5) Allow the neck to flex without impact of the head or neck with any object during the test.

[51 FR 26701, July 25, 1986, as amended at 53 FR 8765, Mar. 17, 1988; 62 FR 27514, May 20, 1997]

§ 572.34 Thorax.

(a) The thorax consists of the upper torso assembly in drawing 78051–89, re-

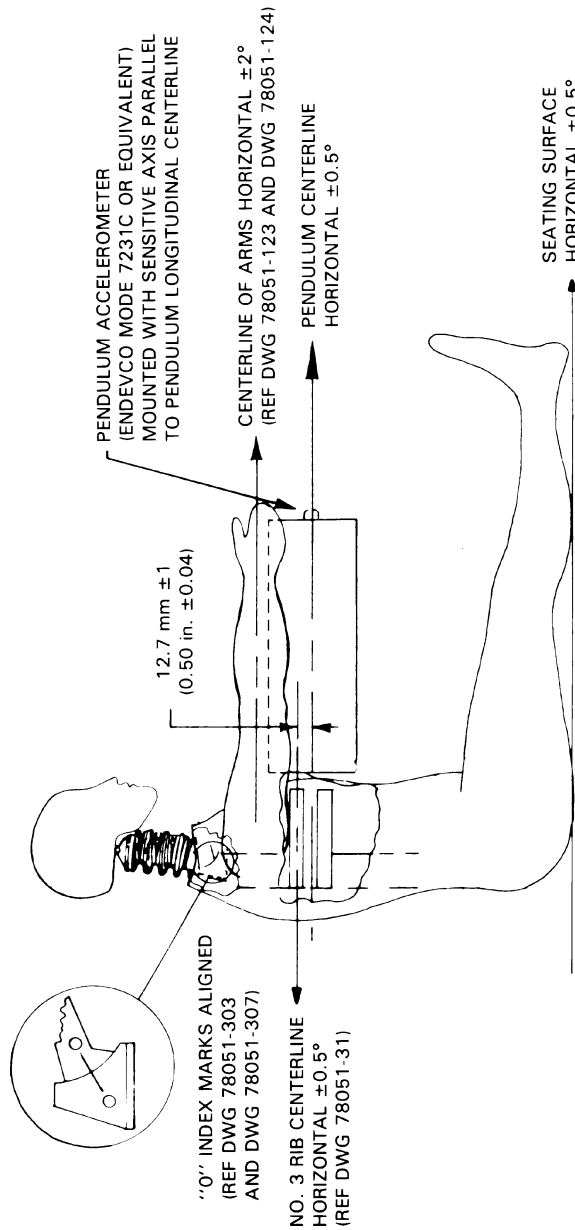
vision K and shall conform to each of the drawings subtended therein.

(b) When impacted by a test probe conforming to § 572.36(a) at 22 fps \pm 0.40 fps in accordance with paragraph (c) of this section, the thorax of a complete dummy assembly (78051–218, revision U, without shoes, shall resist with a force of 1242.5 pounds \pm 82.5 pounds measured by the test probe and shall have a sternum displacement measured relative to spine of 2.68 inches \pm 0.18 inches. The internal hysteresis in each impact shall be more than 69% but less than 85%. The force measured is the product of pendulum mass and deceleration.

(c) *Test procedure.* (1) Soak the test dummy in an environment with a relative humidity from 10% to 70% until the temperature of the ribs of the test dummy have stabilized at a temperature between 69 degrees F and 72 degrees F.

(2) Seat the dummy without back and arm supports on a surface as shown in Figure 23, and set the angle of the pelvic bone at 13 degrees plus or minus 2 degrees, using the procedure described in S11.4.3.2 of Standard No. 208 (§ 571.208 of this chapter).

FIGURE 23
TEST SET-UP SPECIFICATIONS



NOTE: A) NO EXTERNAL SUPPORT IS REQUIRED ON THE DUMMY TO MEET SETUP SPECIFICATIONS

B) THE MIDSAGITTAL PLANE OF THE DUMMY IS VERTICAL ($\pm 1^\circ$) AND WITHIN 2° OF THE CENTERLINE OF THE PENDULUM

C) THE MIDSAGITTAL PLANE OF THE DUMMY IS CENTERED ON THE CENTERLINE OF THE PENDULUM WITHIN 3 mm (0.12 in.)

(3) Place the longitudinal centerline of the test probe so that it is $.5 \pm .04$ in. below the horizontal centerline of the No. 3 Rib (reference drawing number

79051-64, revision A-M) as shown in Figure 23.

§ 572.35

(4) Align the test probe specified in § 572.36(a) so that at impact its longitudinal centerline coincides within .5 degree of a horizontal line in the dummy's midsagittal plane.

(5) Impact the thorax with the test probe so that the longitudinal centerline of the test probe falls within 2 degrees of a horizontal line in the dummy midsagittal plane at the moment of impact.

(6) Guide the probe during impact so that it moves with no significant lateral, vertical, or rotational movement.

(7) Measure the horizontal deflection of the sternum relative to the thoracic spine along the line established by the longitudinal centerline of the probe at the moment of impact, using a potentiometer (ref. drawing 78051-317, revision A) mounted inside the sternum as shown in drawing 78051-89, revision I.

(8) Measure hysteresis by determining the ratio of the area between the loading and unloading portions of the force deflection curve to the area under the loading portion of the curve.

[51 FR 26701, July 25, 1986, as amended at 53 FR 8765, Mar. 17, 1988; 62 FR 27518, May 20, 1997; 63 FR 53851, Oct. 7, 1998]

§ 572.35 Limbs.

(a) The limbs consist of the following assemblies: leg assemblies 86-5001-001, revision A and -002, revision A, and arm assemblies 78051-123, revision D and -124, revision D, and shall conform to the drawings subtended therein.

(b) *Femur impact response.* (1) When each knee of the leg assemblies is impacted in accordance with paragraph (b)(2) of this section, at 6.9 ft/sec \pm 0.10 ft/sec by the pendulum defined in § 572.36(b), the peak knee impact force, which is a product of pendulum mass and acceleration, shall have a minimum value of not less than 1060 pounds and a maximum value of not more than 1300 pounds.

(2) *Test procedure.* (i) The test material consists of leg assemblies (86-5001-001, revision A) left and (-002, revision A) right with upper leg assemblies (78051-46) left and (78051-47) right removed. The load cell simulator (78051-319, revision A) is used to secure the knee cap assemblies (79051-16, revision B) as shown in Figure 24.

49 CFR Ch. V (10-1-10 Edition)

(ii) Soak the test material in a test environment at any temperature between 66 degrees F to 78 degrees F and at a relative humidity from 10% to 70% for a period of at least four hours prior to its application in a test.

(iii) Mount the test material with the leg assembly secured through the load cell simulator to a rigid surface as shown in Figure 24. No contact is permitted between the foot and any other exterior surfaces.

(iv) Place the longitudinal centerline of the test probe so that at contact with the knee it is collinear within 2 degrees with the longitudinal centerline of the femur load cell simulator.

(v) Guide the pendulum so that there is no significant lateral, vertical or rotational movement at time zero.

(vi) Impact the knee with the test probe so that the longitudinal centerline of the test probe at the instant of impact falls within .5 degrees of a horizontal line parallel to the femur load cell simulator at time zero.

(vii) Time zero is defined as the time of contact between the test probe and the knee.

(c) *Hip joint-femur flexion.* (1) When each femur is rotated in the flexion direction in accordance with paragraph (c)(2) of this section, the femur torque at 30 deg. rotation from its initial horizontal orientation will not be more than 70 ft-lbf, and at 150 ft-lbf of torque will not be less than 40 deg. or more than 50 deg.

(2) *Test procedure.* (i) The test material consists of the assembled dummy, part No. 78051-218 (revision S) except that (1) leg assemblies (86-5001-001 and 002) are separated from the dummy by removing the 3/8-16 Socket Head Cap Screw (SHCS) (78051-99) but retaining the structural assembly of the upper legs (78051-43 and -44), (2) the abdominal insert (78051-52) is removed and (3) the instrument cover plate (78051-13) in the pelvic bone is replaced by a rigid pelvic bone stabilizer insert (Figure 25a) and firmly secured.

(ii) Seat the dummy on a rigid seat fixture (Figure 25) and firmly secure it to the seat back by bolting the stabilizer insert and the rigid support device (Figure 25b) to the seat back of the test fixture (Figures 26 and 27) while

maintaining the pelvis (78051-58) "B" plane horizontal.

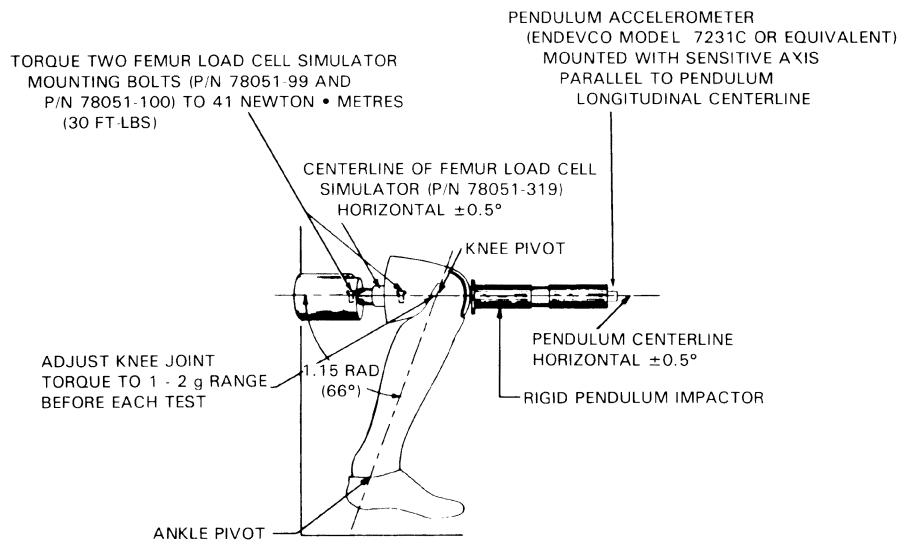
(iii) Insert a lever arm into the femur shaft opening of the upper leg structure assembly (78051-43/44) and firmly secure it using the 3/8-16 socket head cap screws.

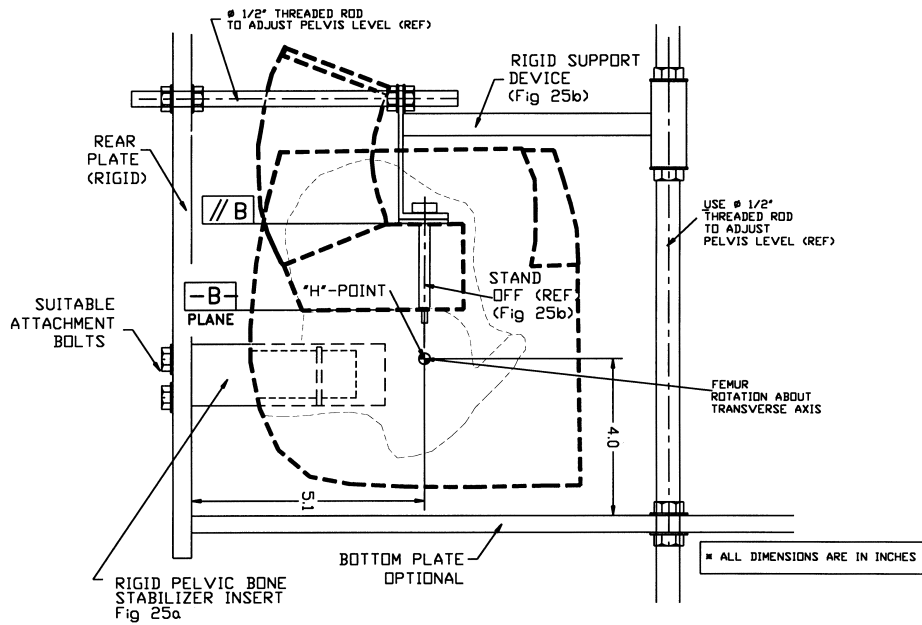
(iv) Lift the lever arm parallel to the midsagittal plane at a rotation rate of 5 to 10 deg. per second while maintain-

ing the 1/2 in. shoulder bolt longitudinal centerline horizontal throughout the range of motion until the 150 ft-lbf torque level is reached. Record the torque and angle of rotation of the femur.

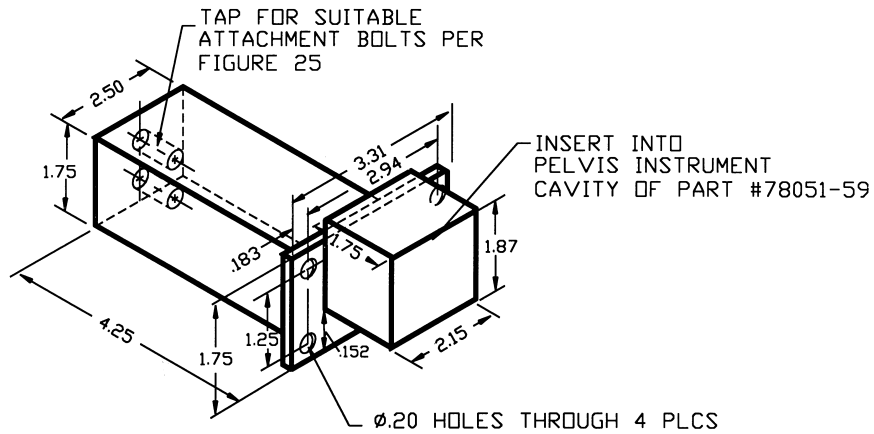
(v) Operating environment and temperature are the same as specified in paragraph (b)(2)(ii) of this section.

FIGURE 24
TEST SET-UP SPECIFICATIONS





HIP-JOINT TEST FIXTURE ASSEMBLY (REF)
 Fig 25



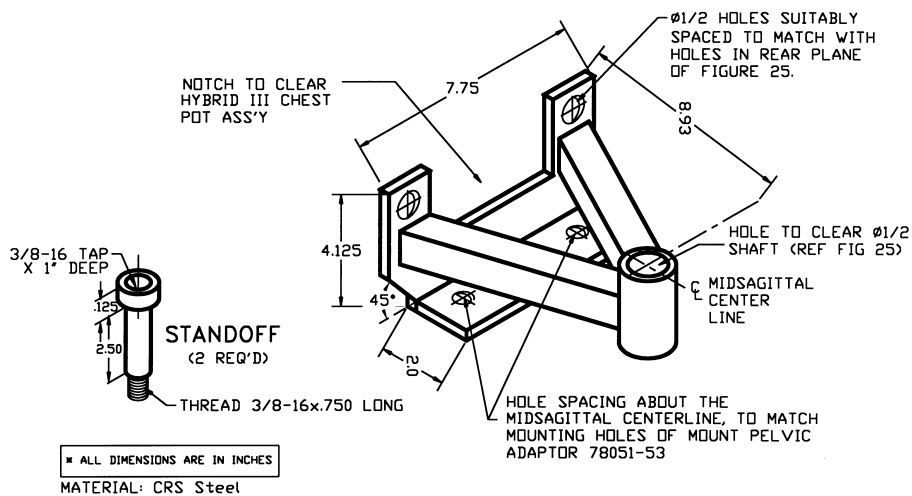
※ ALL DIMENSIONS ARE IN INCHES

MATERIAL: Alum. or Steel

(REF NOTE): HOLE LOCATIONS MATCHING INSTRUMENT CAVITY COVER #78051-13

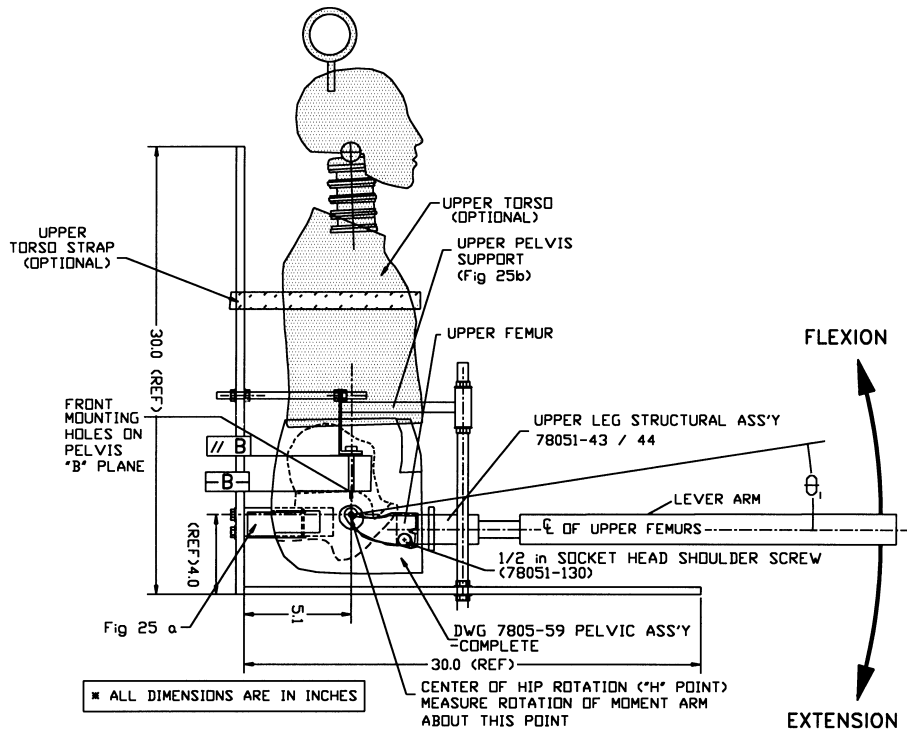
PELVIC BONE STABILIZER INSERT (REF)

Fig 25a



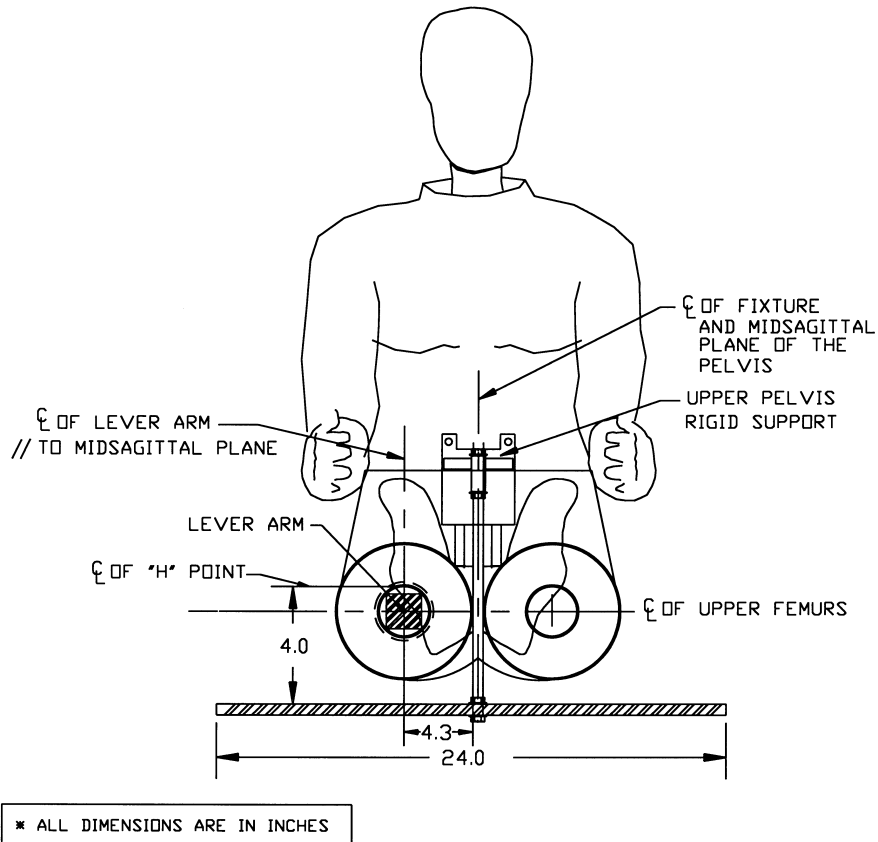
PELVIS UPPER SUPPORT DEVICE (REF)

Fig 25b



HIP JOINT TEST FIXTURE AND TORSO ASSEMBLY (REF)
SIDE VIEW

Fig 26



HIP JOINT TEST FIXTURE AND TORSO ASSEMBLY (REF)
FRONT VIEW

Fig 27

[51 FR 26701, July 25, 1986, as amended at 53 FR 8765, Mar. 17, 1988; 61 FR 67955, Dec. 26, 1997; 63 FR 5748, Feb. 4, 1998]

§ 572.36 Test conditions and instrumentation.

(a) The test probe used for thoracic impact tests is a 6 inch diameter cylinder that weighs 51.5 pounds including instrumentation. Its impacting end has a flat right angle face that is rigid and has an edge radius of 0.5 inches. The test probe has an accelerometer mounted on the end opposite from impact with its sensitive axis colinear to

the longitudinal centerline of the cylinder.

(b) Test probe used for the knee impact tests is a 3 inch diameter cylinder that weighs 11 pounds including instrumentation. Its impacting end has a flat right angle face that is rigid and has an edge radius of 0.02 inches. The test probe has an accelerometer mounted on the end opposite from impact with its sensitive axis colinear to

§ 572.40

the longitudinal centerline of the cylinder.

(c) Head accelerometers shall have dimensions and response characteristics specified in drawing 78051-136, revision A, or its equivalent, and the location of their seismic mass as mounted in the skull are shown in drawing C-1709, revision D.

(d) The six axis neck transducer shall have the dimensions, response characteristics, and sensitive axis locations specified in drawing C-1709, revision D and be mounted for testing as shown in Figures 20 and 21 of § 572.33, and in the assembly drawing 78051-218, revision T.

(e) The chest accelerometers shall have the dimensions, response characteristics, and sensitive mass locations specified in drawing 78051-136, revision A or its equivalent and be mounted as shown with adaptor assembly 78051-116, revision D for assembly into 78051-218, revision T.

(f) The chest deflection transducer shall have the dimensions and response characteristics specified in drawing 78051-342, revision A or its equivalent and be mounted in the chest deflection transducer assembly 78051-317, revision A for assembly into 78051-218, revision T.

(g) The thorax and knee impactor accelerometers shall have the dimensions and characteristics of Endevco Model 7231c or equivalent. Each accelerometer shall be mounted with its sensitive axis colinear with the pendulum's longitudinal centerline.

(h) The femur load cell shall have the dimensions, response characteristics, and sensitive axis locations specified in drawing 78051-265 or its equivalent and be mounted in assemblies 78051-46 and -47 for assembly into 78051-218, revision T.

(i) The outputs of acceleration and force-sensing devices installed in the dummy and in the test apparatus specified by this part are recorded in individual data channels that conform to requirements of Society of Automotive Engineers (SAE) Recommended Practice J211 Mar95, Instrumentation for Impact Tests, Parts 1 and 2. SAE J211 Mar95 sets forth the following channel classes:

- (1) Head acceleration—Class 1000
- (2) Neck forces—Class 1000

49 CFR Ch. V (10-1-10 Edition)

(3) Neck moments—Class 600

(4) Neck pendulum acceleration—Class 60

(5) Thorax and thorax pendulum acceleration—Class 180

(6) Thorax deflection—Class 180

(7) Knee pendulum acceleration—Class 600

(8) Femur force—Class 600

(j) Coordinate signs for instrumentation polarity conform to the sign convention shown in the document incorporated by § 572.31(a)(5).

(k) The mountings for sensing devices shall have no resonance frequency within range of 3 times the frequency range of the applicable channel class.

(l) Limb joints are set at 1g, barely restraining the weight of the limb when it is extended horizontally. The force required to move a limb segment shall not exceed 2g throughout the range of limb motion.

(m) Performance tests of the same component, segment, assembly, or fully assembled dummy are separated in time by period of not less than 30 minutes unless otherwise noted.

(n) Surfaces of dummy components are not painted except as specified in this part or in drawings subtended by this part.

[51 FR 26701, July 25, 1986, as amended at 53 FR 8765, Mar. 17, 1988; 62 FR 27518, May 20, 1997; 63 FR 45965, Aug. 28, 1998]

Subpart F—Side Impact Dummy 50th Percentile Male

SOURCE: 55 FR 45766, Oct. 30, 1990, unless otherwise noted.

§ 572.40 Incorporated materials.

(a) The drawings, specifications, manual, and computer program referred to in this regulation that are not set forth in full are hereby incorporated in this part by reference. These materials are thereby made part of this regulation. The Director of the Federal Register has approved the materials incorporated by reference. For materials subject to change, only the specific version approved by the Director of the Federal Register and specified in the regulation are incorporated. A notice of any change will be published in the FEDERAL REGISTER. As a convenience

to the reader, the materials incorporated by reference are listed in the Finding Aids Table found at the end of this volume of the Code of Federal Regulations.

(b) The materials incorporated in this part by reference are available for examination in the general reference section of Docket 79-04, Docket Section, National Highway Traffic Safety Administration, room 5109, 400 Seventh St., S.W., Washington, D.C., 20590, telephone (202) 366-4949. Copies may be obtained from Reprographic Technologies, 9000 Virginia Manor Rd., Suite 210, Beltsville, MD, 20705, Telephone (301) 419-5070, Fax (301) 419-5069.

[55 FR 45766, Oct. 30, 1990, as amended at 63 FR 16140, Apr. 2, 1998]

§ 572.41 General description.

(a) The dummy consists of component parts and component assemblies (SA-SID-M001, revision C, dated September 12, 1996, and SA-SID-M001A, revision B, dated September 12, 1996), which are described in approximately 250 drawings and specifications that are set forth in § 572.5(a) of this chapter with the following changes and additions which are described in approximately 85 drawings and specifications (incorporated by reference; see § 572.40):

(1) The head assembly consists of the assembly specified in subpart B (§ 572.6(a)) and conforms to each of the drawings subtended under drawing SA 150 M010 and drawings specified in SA-SID-M010, dated August 13, 1987.

(2) The neck assembly consists of the assembly specified in subpart B (§ 572.7(a)) and conforms to each of the drawings subtended under drawing SA 150 M020 and drawings shown in SA-SID-M010, dated August 13, 1987.

(3) The thorax assembly consists of the assembly shown as number SID-053 and conforms to each applicable drawing subtended by number SA-SID-M030 revision A, dated May 18, 1994.

(4) The lumbar spine consists of the assembly specified in subpart B (§ 572.9(a)) and conforms to drawing SA 150 M050 and drawings subtended by SA-SID-M050 revision B, dated September 12, 1996, including the addition of Lumbar Spacers-Lower SID-SM-001 and Lumbar Spacers-Upper SID-SM-002

(both dated May 12, 1994), and Washer 78051-243.

(5) The abdomen and pelvis consist of the assembly specified in subpart B of this part (§ 572.9) and conform to the drawings subtended by SA 150 M060, the drawings subtended by SA-SID-M060 revision A, dated May 18, 1994, and the drawings subtended by SA-SID-087 sheet 1 revision H, dated May 18, 1994, and SA-SID-087 sheet 2 revision H.

(6) The lower limbs consist of the assemblies specified in subpart B (§ 572.10) shown as SA 150 M080 and SA 150 M081 in Figure 1 and SA-SID-M080 and SA-SID-M081, both dated August 13, 1987, and conform to the drawings subtended by those numbers.

(b) The structural properties of the dummy are such that the dummy conforms to the requirements of this subpart in every respect both before and after being used in vehicle tests specified in Standard No 214 § 571.214 of this chapter.

(c) Disassembly, inspection, and assembly procedures; external dimensions and weight; and a dummy drawing list are set forth in the Side Impact Dummy (SID) User's Manual, dated May 1994 except for pages 7, 20 and 23, and appendix A (consisting of replacement pages 7, 20 and 23) dated January 20, 1998 (incorporated by reference; see § 572.40).

[55 FR 45766, Oct. 30, 1990, as amended at 59 FR 52091, Oct. 14, 1994; 63 FR 16140, Apr. 2, 1998]

§ 572.42 Thorax.

(a) When the thorax of a completely assembled dummy (SA-SID-M001A revision A, dated May 18, 1994, incorporated by reference; see § 572.40), appropriately assembled for right or left side impact, is impacted by a test probe conforming to § 572.44(a) at 14 fps in accordance with paragraph (b) of this section, the peak accelerations at the location of the accelerometers mounted on the thorax in accordance with § 572.44(b) shall be:

(1) For the accelerometer at the top of the Rib Bar on the struck side (LUR or RUR) not less than 37 g's and not more than 46 g's.

(2) For the accelerometer at the bottom of the Rib Bar on the struck side

§ 572.43

(LLR or RLR) not less than 37 g's and not more than 46 g's.

(3) For the lower thoracic spine (T12) not less than 15 g's and not more than 22 g's.

(b) Test Procedure. (1) Adjust the dummy legs as specified in § 572.44(f). Seat the dummy on a seating surface as specified in § 572.44(h) with the limbs extended horizontally forward.

(2) Place the longitudinal centerline of the test probe at the lateral side of the chest at the intersection of the centerlines of the third rib and the Rib Bar on the desired side of impact. This is the left side if the dummy is to be used on the driver's side of the vehicle and the right side if the dummy is to be used on the passenger side of the vehicle. The probe's centerline is perpendicular to thorax's midsagittal plane.

(3) Align the test probe so that its longitudinal centerline coincides with the line formed by the intersection of the transverse and frontal planes perpendicular to the chest's midsagittal plane passing through the designated impact point.

(4) Position the dummy as specified in § 572.44(h), so that the thorax's midsagittal plane and tangential plane to the Hinge Mounting Block (Drawing SID-034) are vertical.

(5) Impact the thorax with the test probe so that at the moment of impact at the designated impact point, the probe's longitudinal centerline falls within 2 degrees of a horizontal line perpendicular to the dummy's midsagittal plane and passing through the designated impact point.

(6) Guide the probe during impact so that it moves with no significant lateral, vertical or rotational movement.

(7) Allow a time period of at least 20 minutes between successive tests of the chest.

[59 FR 52091, Oct. 14, 1994, as amended at 59 FR 52091, Oct. 14, 1994]

§ 572.43 Lumbar spine and pelvis.

(a) When the pelvis of a fully assembled dummy (SA-SID-M001A revision B, dated September 12, 1996, (incorporated by reference; see § 572.40) is impacted laterally by a test probe conforming to § 572.44(a) at 14 fps in accordance with paragraph (b) of this section, the peak acceleration at the location of the ac-

49 CFR Ch. V (10-1-10 Edition)

celerometer mounted in the pelvis cavity in accordance with § 572.44(c) shall be not less than 40g and not more than 60g. The acceleration-time curve for the test shall be unimodal and shall lie at or above the +20g level for an interval not less than 3 milliseconds and not more than 7 milliseconds.

(b) Test Procedure. (1) Adjust the dummy legs as specified in § 572.44(f). Seat the dummy on a seating surface as specified in § 572.44(h) with the limbs extended horizontally forward.

(2) Place the longitudinal centerline of the test probe at the lateral side of the pelvis at a point 3.9 inches vertical from the seating surface and 4.8 inches ventral to a transverse vertical plane which is tangent to the back of the dummy's buttocks.

(3) Align the test probe so that at impact its longitudinal centerline coincides with the line formed by intersection of the horizontal and vertical planes perpendicular to the midsagittal plane passing through the designated impact point.

(4) Adjust the dummy so that its midsagittal plane is vertical and the rear surfaces of the thorax and buttocks are tangent to a transverse vertical plane.

(5) Impact the pelvis with the test probe so that at the moment of impact the probe's longitudinal centerline falls within 2 degrees of the line specified in paragraph (b)(3) of this section.

(6) Guide the test probe during impact so that it moves with no significant lateral, vertical or rotational movement.

(7) Allow a time period of at least 2 hours between successive tests of the pelvis.

[55 FR 45766, Oct. 30, 1990, as amended at 59 FR 52091, Oct. 14, 1994; 63 FR 16140, Apr. 2, 1998]

§ 572.44 Instrumentation and test conditions.

(a) The test probe used for lateral thoracic and pelvis impact tests is a 6 inch diameter cylinder that weighs 51.5 pounds including instrumentation. Its impacting end has a flat right angle face that is rigid and has an edge radius of 0.5 inches.

(b) Three accelerometers are mounted in the thorax for measurement of

lateral accelerations with each accelerometer's sensitive axis aligned to be closely perpendicular to the thorax's midsagittal plane. The accelerometers are mounted in the following locations:

(1) One accelerometer is mounted on the thorax to lumbar adaptor (SID-005 revision F, dated May 18, 1994, incorporated by reference; see § 572.40) with seismic mass center located 0.5 inches toward the impact side, 0.1 inches upward and 1.86 inches rearward from the reference point shown in Figure 30 in appendix A to subpart F of part 572. Maximum permissible variation of the seismic location must not exceed 0.2 inches spherical radius.

(2) Two accelerometers are mounted, one on the top and the other at the bottom part of the Rib Bar (SID-024) on the struck side. Their seismic mass centers are at any distance up to .4 inches from a point on the Rib Bar surface located on its longitudinal center line .75 inches from the top for the top accelerometer and .75 inches from the bottom, for the bottom accelerometer.

(c) One accelerometer is mounted in the pelvis for measurement of the lateral acceleration with its sensitive axis perpendicular to the pelvic midsagittal plane. The accelerometer is mounted on the rear wall of the instrumentation cavity of the pelvis (SID-087 revision H, dated May 18, 1994, incorporated by reference; see § 572.40). The accelerometer's seismic mass with respect to the mounting bolt center line is 0.9 inches up, 0.7 inches to the left for left side impact and 0.03 inches to the left for right side impact, and 0.5 inches rearward from the rear wall mounting surface as shown in Figure 31 in appendix A to subpart F of part 572. Maximum permissible variation of the seismic location must not exceed 0.2 inches spherical radius.

(d) Instrumentation and sensors used must conform to the SAE J-211 (1980) recommended practice requirements (incorporated by reference; see § 572.40). The outputs of the accelerometers installed in the dummy are then processed with the software for the Finite Impulse Response (FIR) filter (FIR 100 software). The FORTRAN program for this FIR 100 software (FIR100 Filter Program, Version 1.0, July 16, 1990) is

incorporated by reference in this part (see § 572.40). The data are processed in the following manner:

(1) Analog data recorded in accordance with SAE J-211 (1980) recommended practice channel class 1000 specification.

(2) Filter the data with a 300 Hz, SAE Class 180 filter;

(3) Subsample the data to a 1600 Hz sampling rate;

(4) Remove the bias from the subsampled data, and

(5) Filter the data with the FIR100 Filter Program (Version 1.0, July 16, 1990), which has the following characteristics—

(i) Passband frequency, 100 Hz.

(ii) Stopband frequency, 189 Hz.

(iii) Stopband gain, -50 db.

(iv) Passband ripple, 0.0225 db.

(e) The mountings for the spine, rib and pelvis accelerometers shall have no resonance frequency within a range of 3 times the frequency range of the applicable channel class.

(f) Limb joints of the test dummy are set at the force between 1-2 g's, which just supports the limbs' weight when the limbs are extended horizontally forward. The force required to move a limb segment does not exceed 2 g's throughout the range of limb motion.

(g) Performance tests are conducted at any temperature from 66 °F to 78 °F and at any relative humidity from 10 percent to 70 percent after exposure of the dummy to these conditions for a period of not less than 4 hours.

(h) For the performance of tests specified in §§ 572.42 and 572.43, the dummy is positioned as follows:

(1) The dummy is placed on a flat, rigid, clean, dry, horizontal smooth aluminum surface whose length and width dimensions are not less than 16 inches, so that the dummy's midsagittal plane is vertical and centered on the test surface. The dummy's torso is positioned to meet the requirements of § 572.42 and § 572.43. The seating surface is without the back support and the test dummy is positioned so that the dummy's midsagittal plane is vertical and centered on the seat surface.

(2) The legs are positioned so that their centerlines are in planes parallel to the midsagittal plane.

§ 572.44

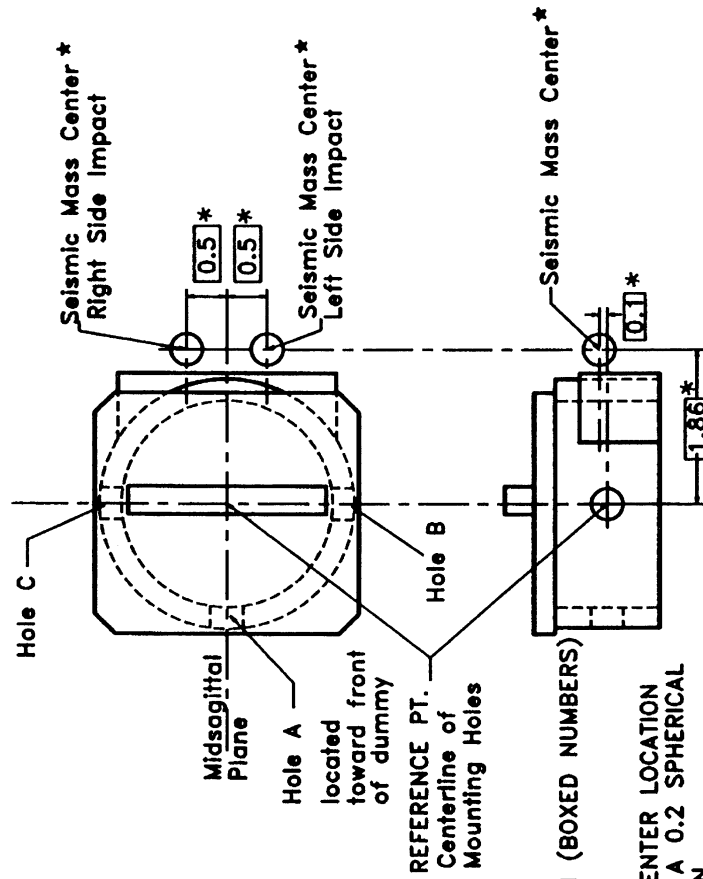
(3) Performance pre-tests of the assembled dummy are separated in time by a period of not less than 20 minutes unless otherwise specified.

49 CFR Ch. V (10–1–10 Edition)

(4) Surfaces of the dummy components are not painted except as specified in this part or in drawings subtended by this part.

[55 FR 45766, Oct. 30, 1990, as amended at 56 FR 47011, Sept. 17, 1991; 59 FR 52091, Oct. 14, 1994]

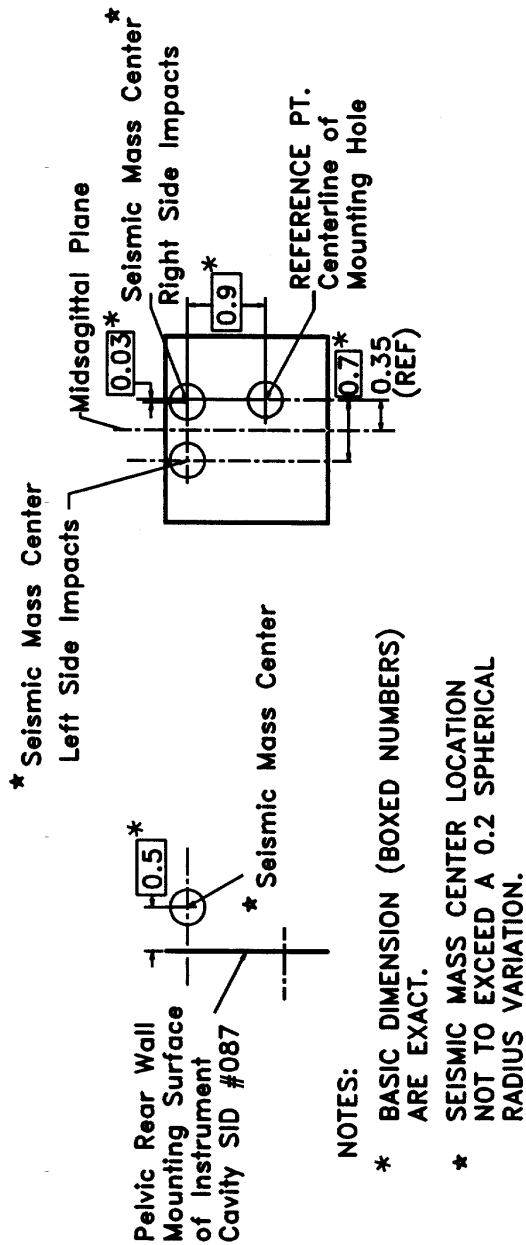
APPENDIX A TO SUBPART F OF PART 572—FIGURES



NOTES:

- * BASIC DIMENSION (BOXED NUMBERS) ARE EXACT.
- * SEISMIC MASS CENTER LOCATION NOT TO EXCEED A 0.2 SPHERICAL RADIUS VARIATION.

Accelerometer Seismic Mass Location on Assembly SID #005
 FIGURE 30



Pelvis Accelerometer Seismic Mass Location

FIGURE 31

[59 FR 52092, Oct. 14, 1994]

Subparts G–H [Reserved]

Subpart I—6-Year-Old Child

SOURCE: 56 FR 57836, Nov. 14, 1991, unless otherwise noted.

§ 572.70 Incorporation by reference.

(a) The drawings and specifications referred to in §§ 572.71(a) and 572.71(b) are hereby incorporated in subpart I by reference. These materials are thereby made part of this regulation. The Director of the Federal Register approved the materials incorporated by reference in accordance with 5 U.S.C. 552(a) and 1 CFR part 51. Copies of the materials may be inspected at NHTSA's Docket Section, 400 Seventh Street, SW., room 5109, Washington, DC, or at the National Archives and Records Administration (NARA). For information on the availability of this material at NARA, call 202-741-6030, or go to: http://www.archives.gov/federal_register/code_of_federal_regulations/ibr_locations.html.

(b) The incorporated material is available as follows:

(1) Drawing number SA 106 C001 sheets 1 through 18, and the drawings listed in the parts lists described on sheets 8 through 17, are available from

Reprographic Technologies, 9000 Virginia Manor Rd., Beltsville, MD 20705, Telephone (301) 210-5600, Fax (301) 210-5607.

(2) A User's Manual entitled, "Six-Year-Old Size Child Test Dummy SA106C," October 28, 1991, is available from Reprographic Technologies at the address in paragraph (b)(1) of this section.

(3) SAE Recommended Practice J211, Instrumentation for Impact Test, June 1988, is available from the Society of Automotive Engineers, Inc., 400 Commonwealth Drive, Warrendale, PA 15096-0001.

[56 FR 57836, Nov. 14, 1991, as amended at 62 FR 44226, Aug. 20, 1997]

§ 572.71 General description.

(a) The representative 6-year-old dummy consists of a drawings and specifications package that contains the following materials:

(1) Technical drawings, specifications, and the parts list package shown in SA 106C 001, sheets 1 through 18, released July 11, 1997;

(2) A user's manual entitled, "Six-Year-Old Size Child Test Dummy SA106C," October 28, 1991.

(b) The dummy is made up of the component assemblies set out in Table A:

TABLE A

Assembly drawing No.	Drawing title	Listed on drawing No.	Revision
SA 106C 010	Head Assembly	SA 106C 001, sheet 8	A
SA 106C 020	Neck Assembly	SA 106C 001, sheet 9	A
SA 106C 030	Thorax Assembly	SA 106C 001, sheet 10	C
SA 106C 030	Thorax Assembly	SA 106C 001, sheet 11	D
SA 106C 041	Arm Assembly (right)	SA 106C 001, sheet 14	A
SA 106C 042	Arm Assembly (left)	SA 106C 001, sheet 15	A
SA 106C 050	Lumbar Spine Assembly	SA 106C 001, sheet 12	A
SA 106C 060	Pelvis Assembly	SA 106C 001, sheet 13	A
SA 106C 071	Leg Assembly (right)	SA 106C 001, sheet 16	A
SA 106C 072	Leg Assembly (left)	SA 106C 001, sheet 17	A

(c) Adjacent segments are joined in a manner such that except for contacts existing under static conditions, there is no contact between metallic elements throughout the range of motion or under simulated crash-impact conditions.

(d) The structural properties of the dummy are such that the dummy conforms to this part in every respect both

before and after its use in any test similar to those specified in Standard 213, Child Restraint Systems.

[56 FR 57836, Nov. 14, 1991, as amended at 62 FR 44226, Aug. 20, 1997]

§ 572.72 Head assembly and test procedure.

(a) *Head assembly.* The head consists of the assembly designated as SA 106

§572.73

010 on drawing No. SA 106C 001, sheet 2, and conforms to each drawing listed on SA 106C 001, sheet 8.

(b) *Head assembly impact response requirements.* When the head is impacted by a test probe conforming to §572.77(a)(1) at 7 feet per second (fps) according to the test procedure in paragraph (c) of this section, then the resultant head acceleration measured at the location of the accelerometer installed in the headform according to §572.77(b) is not less than 130g and not more than 160g.

(1) The recorded acceleration-time curve for this test is unimodal at or above the 50g level, and lies at or above that level for an interval not less than 1.0 and not more than 2.0 milliseconds.

(2) The lateral acceleration vector does not exceed 5g.

(c) *Head test procedure.* The test procedure for the head is as follows:

(1) Seat and orient the dummy on a seating surface having a back support as specified in §572.78(c), and adjust the joints of the limbs at any setting (between 1g and 2g) which just supports the limbs' weight when the limbs are extended horizontally and forward.

(2) Adjust the test probe so that its longitudinal center line is—

(i) At the forehead at the point of orthogonal intersection of the head midsagittal plane and the transverse plane which is perpendicular to the Z axis of the head as shown in Figure 40;

(ii) Located 2.7 ±0.1 inches below the top of the head measured along the Z axis, and;

(iii) Coincides within 2 degrees with the line made by the intersection of the horizontal and midsagittal planes passing through this point.

(3) Impact the head with the test probe so that at the moment of contact the probe's longitudinal center line falls within 2 degrees of a horizontal line in the dummy's midsagittal plane.

(4) Guide the test probe during impact so that there is no significant lateral, vertical, or rotational movement.

(5) Allow at least 60 minutes between successive head tests.

§572.73 Neck assembly and test procedure.

(a) *Neck assembly.* The neck consists of the assembly designated as SA 106C

49 CFR Ch. V (10–1–10 Edition)

020 on drawing SA 106C 001, sheet 2, and conforms to each drawing listed on SA 106C 001, sheet 9.

(b) *Neck assembly impact response requirements.* When the head-neck assembly (SA 106C 010 and SA 106C 020) is tested according to the test procedure in §572.73(c), the head:

(1) Shall rotate, while translating in the direction of the pendulum preimpact flight, in reference to the pendulum's longitudinal center line a total of 78 degrees ±6 degrees about the head's center of gravity; and

(2) Shall rotate to the extent specified in Table B at each indicated point in time, measured from time of impact, with the chordal displacement measured at the head's center of gravity.

(i) Chordal displacement at time "T" is defined as the straight line distance between the position relative to the pendulum arm of the head's center of gravity at time "zero;" and the position relative to the pendulum arm of the head's center of gravity at time T as illustrated by Figure 3 in §572.11.

(ii) The peak resultant acceleration recorded at the location of the accelerometers mounted in the headform according to §572.77(b) shall not exceed 30g.

TABLE B

Rotation (degrees)	Time (ms) ±(2+.08T)	Chordal displacement (inches) ±0.8
0	0	0
30	26	2.7
60	44	4.3
Maximum	68	5.8
60	101	4.4
30	121	2.4
0	140	0

(3) The pendulum shall not reverse direction until the head's center of gravity returns to the original "zero" time position relative to the pendulum arm.

(c) *Neck test procedure.* The test procedure for the neck is as follows:

(1) Mount the head and neck assembly on a rigid pendulum as specified in §572.21, Figure 15, so that the head's midsagittal plane is vertical and coincides with the plane of motion of the pendulum's longitudinal center line. Attach the neck directly to the pendulum as shown in §572.21, Figure 15.

(2) Release the pendulum and allow it to fall freely from a height such that the velocity at impact is 17.00 ± 1.0 fps, measured at the center of the accelerometer specified in § 572.21, Figure 15.

(3) Decelerate the pendulum to a stop with an acceleration-time pulse described as follows:

(i) Establish 5g and 20g levels on the a-t curve.

(ii) Establish t_1 at the point where the rising a-t curve first crosses the 5g level; t_2 at the point where the rising a-t curve first crosses the 20g level; t_3 at the point where the decaying a-t curve last crosses the 20g level; and t_4 at the point where the decaying a-t curve first crosses the 5g level.

(iii) $t_2 - t_1$ shall not be more than 3 milliseconds.

(iv) $t_3 - t_2$ shall not be more than 22 milliseconds, and not less than 19 milliseconds.

(v) $t_4 - t_3$ shall not be more than 6 milliseconds.

(vi) The average deceleration between t_2 and t_3 shall not be more than 26g, or less than 22g.

(4) Allow the neck to flex without the head or neck contacting any object other than the pendulum arm.

(5) Allow at least 60 minutes between successive tests.

[56 FR 57836, Nov. 14, 1991, as amended at 57 FR 4086, Feb. 3, 1992]

§ 572.74 Thorax assembly and test procedure.

(a) *Thorax assembly.* The thorax consists of the part of the torso assembly designated as SA 106C 030 on drawing SA 106C 001, sheet 2, Revision A, and conforms to each applicable drawing on SA 106C 001 sheet 10, Revision C (including Drawing number 6C-1610-1 thru -4, Revision A, titled "Screw Button Head Socket", dated September 30, 1996, and Drawing number 6C-1021, Revision B, titled "Ballast, 6 Yr. Thoraxc (for 7267A)", dated September 24, 1996), and sheet 11, Revision D (including Drawing number SA 6C-909, Revision A, titled "Cover-chest Accelerometer", dated September 21, 1996, and Drawing number 6C-1000-1, Revision C, titled "Sternum Thoracic Weld Ass'y.", dated September 24, 1996).

(b) *Thorax assembly requirements.* When the thorax is impacted by a test

probe conforming to § 572.77(a) to 20 ± 0.3 fps according to the test procedure in paragraph (c) of this section, the peak resultant accelerations at the accelerometers mounted in the chest cavity according to § 572.77(c) shall not be less than 43g and not more than 53g.

(1) The recorded acceleration-time curve for this test shall be unimodal at or above the 30g level, and shall lie at or above that level for an interval not less than 4 milliseconds and not more than 6 milliseconds.

(2) The lateral accelerations shall not exceed 5g.

(c) *Thorax test procedure.* The test procedure for the thorax is as follows:

(1) Seat and orient the dummy on a seating surface without back support as specified in § 572.78(c), and adjust the joints of the limbs at any setting (between 1g and 2g) which just supports the limbs' weight when the limbs are extended horizontally and forward, parallel to the midsagittal plane.

(2) Establish the impact point at the chest midsagittal plane so that the impact point is 2.25 inches below the longitudinal center of the clavicle retainer screw, and adjust the dummy so that the plane that bisects the No. 3 rib into upper and lower halves is horizontal ± 1 degree.

(3) Place the longitudinal center line of the test probe so that it coincides with the designated impact point, and align the test probe so that at impact, the probe's longitudinal center line coincides (within 2 degrees) with the line formed at the intersection of the horizontal and midsagittal planes and passing through the designated impact point.

(4) Impact the thorax with the test probe so that at the moment of contact the probe's longitudinal center line falls within 2 degrees of a horizontal line in the dummy's midsagittal plane.

(5) Guide the test probe during impact so that there is no significant lateral, vertical, or rotational movement.

(6) Allow at least 30 minutes between successive tests.

[56 FR 57836, Nov. 14, 1991, as amended at 60 FR 2897, Jan. 12, 1995; 62 FR 44227, Aug. 20, 1997]

§ 572.75

§ 572.75 Lumbar spine, abdomen, and pelvis assembly and test procedure.

(a) *Lumbar spine, abdomen, and pelvis assembly.* The lumbar spine, abdomen, and pelvis consist of the part of the torso assembly designated as SA 106C 50 and 60 on drawing SA 106C 001, sheet 2, and conform to each applicable drawing listed on SA 106C 001, sheets 12 and 13.

(b) *Lumbar spine, abdomen, and pelvis assembly response requirements.* When the lumbar spine is subjected to a force continuously applied according to the test procedure set out in paragraph (c) of this section, the lumbar spine assembly shall—

(1) Flex by an amount that permits the rigid thoracic spine to rotate from the torso's initial position, as defined in (c)(3), by 40 degrees at a force level of not less than 46 pounds and not more than 52 pounds, and

(2) Straighten upon removal of the force to within 5 degrees of its initial position when the force is removed.

(c) *Lumbar spine, abdomen, and pelvis test procedure.* The test procedure for the lumbar spine, abdomen, and pelvis is as follows:

(1) Remove the dummy's head-neck assembly, arms, and lower legs, clean and dry all component surfaces, and seat the dummy upright on a seat as specified in Figure 42.

(2) Adjust the dummy by—

(i) Tightening the femur ballflange screws at each hip socket joint to 50 inch-pounds torque;

(ii) Attaching the pelvis to the seating surface by a bolt D/605 as shown in Figure 42.

(iii) Attaching the upper legs at the knee joints by the attachments shown in drawing Figure 42.

(iv) Tightening the mountings so that the pelvis-lumbar joining surface is horizontal; and

(v) Removing the head and neck, and installing a cylindrical aluminum adapter (neck adapter) of 2.0 inches diameter and 2.60 inches length as shown in Figure 42.

(3) The initial position of the dummy's torso is defined by the plane formed by the rear surfaces of the shoulders and buttocks which is three to seven degrees forward of the transverse vertical plane.

49 CFR Ch. V (10–1–10 Edition)

(4) Flex the thorax forward 50 degrees and then rearward as necessary to return the dummy to its initial torso position, unsupported by external means.

(5) Apply a forward pull force in the midsagittal plane at the top of the neck adapter so that when the lumbar spine flexion is 40 degrees, the applied force is perpendicular to the thoracic spine box.

(i) Apply the force at any torso deflection rate between 0.5 and 1.5 degrees per second, up to 40 degrees of flexion.

(ii) For 10 seconds, continue to apply a force sufficient to maintain 40 degrees of flexion, and record the highest applied force during the 10 second period.

(iii) Release all force as rapidly as possible, and measure the return angle 3 minutes after the release.

§ 572.76 Limbs assembly and test procedure.

(a) *Limbs assembly.* The limbs consist of the assemblies designated as SA 106C 041, SA 106C 042, SA 106C 071, and SA 106C 072, on drawing No. SA 106C 001, sheet 2, and conform to each applicable drawing listed on SA 106C 001, sheets 14 through 17.

(b) *Limbs assembly impact response requirement.* When each knee is impacted at 7.0 ± 0.1 fps, according to paragraph (c) of this section, the maximum force on the femur shall not be more than 1060 pounds and not less than 780 pounds, with a duration above 400 pounds of not less than 0.8 milliseconds.

(c) *Limbs test procedure.* The test procedure for the limbs is as follows:

(1) Seat and orient the dummy without back support on a seating surface that is 11 ± 0.2 inches above a horizontal (floor) surface as specified in § 572.78(c).

(i) Orient the dummy as specified in Figure 43 with the hip joint adjustment at any setting between 1g and 2g.

(ii) Place the dummy legs in a plane parallel to the dummy's midsagittal plane with the knee pivot center line perpendicular to the dummy's midsagittal plane, and with the feet flat on the horizontal (floor) surface.

(iii) Adjust the feet and lower legs until the line between the midpoint of

each knee pivot and each ankle pivot is within 2 degrees of the vertical.

(2) If necessary, reposition the dummy so that at the level one inch below the seating surface, the rearmost point of the dummy's lower legs remains not less than 3 inches and not more than 6 inches forward of the forward edge of the seat.

(3) Align the test probe specified in § 572.77(a) with the longitudinal center line of the femur force gauge, so that at impact, the probe's longitudinal center line coincides with the sensor's longitudinal center line within ± 2 degrees.

(4) Impact the knee with the test probe moving horizontally and parallel to the midsagittal plane at the specified velocity.

(5) Guide the test probe during impact so that there is no significant lateral, vertical, or rotational movement.

§ 572.77 Instrumentation.

(a)(1) *Test probe.* For the head, thorax, and knee impact test, use a test probe that is rigid, of uniform density and weighs 10 pounds and 6 ounces, with a diameter of 3 inches; a length of 13.8 inches; and an impacting end that has a rigid flat right face and edge radius of 0.5 inches.

(2) The head and thorax assembly may be instrumented either with a Type A or Type B accelerometer.

(i) Type A accelerometer is defined in drawing SA 572 S1.

(ii) Type B accelerometer is defined in drawing SA 572 S2.

(b) *Head accelerometers.* (1) Install accelerometers in the head as shown in drawing SA 106C 001 sheet 1 using suitable spacers or adaptors as needed to affix them to the horizontal transverse bulkhead so that the sensitive axes of the three accelerometers intersect at the point in the midsagittal plane located 0.4 inches below the intersection of a line connecting the longitudinal center lines of the roll pins in either side of the dummy's head with the head's midsagittal plane.

(2) The head has three orthogonally mounted accelerometers aligned as follows:

(i) Align one accelerometer so that its sensitive axis is perpendicular to the horizontal bulkhead in the midsagittal plane.

(ii) Align the second accelerometer so that its sensitive axis is parallel to the horizontal bulkhead, and perpendicular to the midsagittal plane.

(iii) Align the third accelerometer so that its sensitive axis is parallel to the horizontal bulkhead in the midsagittal plane.

(iv) The seismic mass center for any of these accelerometers may be at any distance up to 0.4 inches from the axial intersection point.

(c) *Thoracic accelerometers.* (1) Install accelerometers in the thoracic assembly as shown in drawing SA 106C 001, sheet 1, using suitable spacers and adaptors to affix them to the frontal surface of the spine assembly so that the sensitive axes of the three accelerometers intersect at a point in the midsagittal plane located 0.95 inches posterior of the spine mounting surface, and 0.55 inches below the horizontal centerline of the two upper accelerometer mount attachment hole centers.

(2) The sternum-thoracic assembly has three orthogonally mounted accelerometers aligned as follows:

(i) Align one accelerometer so that its sensitive axis is parallel to the attachment surface in the midsagittal plane.

(ii) Align the second accelerometer so that its sensitive axis is parallel to the attachment surface, and perpendicular to the midsagittal plane.

(iii) Align the third accelerometer so that its sensitive axis is perpendicular to the attachment surface in the midsagittal plane.

(iv) The seismic mass center for any of these accelerometers may be at any distance up to 0.4 inches of the axial intersection point.

(d) *Femur-sensing device.* Install a force-sensing device SA 572-S10 axially in each femur shaft as shown in drawing SA 106C 072 and secure it to the femur assembly so that the distance measured between the center lines of two attachment bolts is 3.00 inches.

(e) *Limb joints.* Set the limb joints at 1g, barely restraining the limb's weight when the limb is extended horizontally, and ensure that the force required to move the limb segment does not exceed 2g throughout the limb's range of motion.

§ 572.78

49 CFR Ch. V (10–1–10 Edition)

(f) *Recording outputs.* Record the outputs of acceleration and force-sensing devices installed in the dummy and in the test apparatus specified in this part, in individual channels that conform to the requirements of SAE Recommended Practice J211, October 1988, with channel classes as set out in the following table C.

TABLE C

Device	Channel
Head acceleration	Class 1000
Pendulum acceleration	Class 60
Thorax acceleration	Class 180
Femur-force	Class 600

The mountings for sensing devices shall have no resonance frequency within a range of 3 times the frequency range of the applicable channel class.

§ 572.78 Performance test conditions.

(a) Conduct performance tests at any temperature from 66 °F to 78 °F, and at any relative humidity from 10 percent to 70 percent, but only after having first exposed the dummy to these conditions for a period of not less than 4 hours.

(b) For the performance tests specified in § 572.72 (head), § 572.74 (thorax), § 572.75 (lumbar spine, abdomen, and pelvis), and § 572.76 (limbs), position the dummy as set out in paragraph (c) of this section.

(c) Place the dummy on a horizontal seating surface covered by teflon sheeting so that the dummy's midsagittal plane is vertical and centered on the test surface.

(1) The seating surface is flat, rigid, clean, and dry, with a smoothness not

exceeding 40 microinches, a length of at least 16 inches, and a width of at least 16 inches.

(2) For head impact tests, the seating surface has a vertical back support whose top is 12.4 ±0.2 inches above the horizontal surface, and the rear surfaces of the dummy's back and buttocks touch the back support as shown in Figure 40.

(3) For the thorax, lumbar spine, and knee tests, the horizontal surface is without a back support as shown in Figure 41 (for the thorax); Figure 42 (for the lumbar spine); and Figure 43 (for the knee).

(4) Position the dummy's arms and legs so that their center lines are in planes parallel to the midsagittal plane.

(5) Adjust each shoulder yoke so that with its upper surface horizontal, a yoke is at the midpoint of its anterior-posterior travel.

(6) Adjust the dummy for head and knee impact tests so that the rear surfaces of the shoulders and buttocks are tangent to a transverse vertical plane.

(d) The dummy's dimensions are specified in drawings SA 106C 001, sheet 3, Revision A, July 11, 1997, and sheets 4 through 6.

(e) Unless otherwise specified in this regulation, performance tests of the same component, segment, assembly or fully assembled dummy are separated in time by a period of not less than 20 minutes.

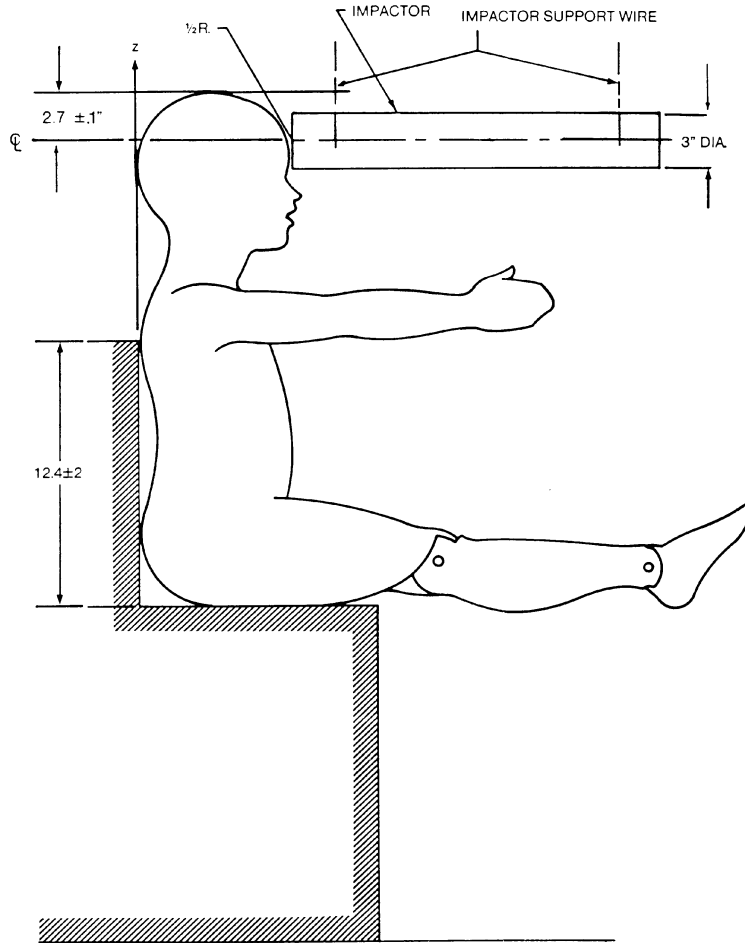
(f) Unless otherwise specified in this regulation, the surfaces of the dummy components are not painted.

[56 FR 57836, Nov. 14, 1991, as amended at 62 FR 44227, Aug. 20, 1997]

FIGURES TO SUBPART I OF PART 572

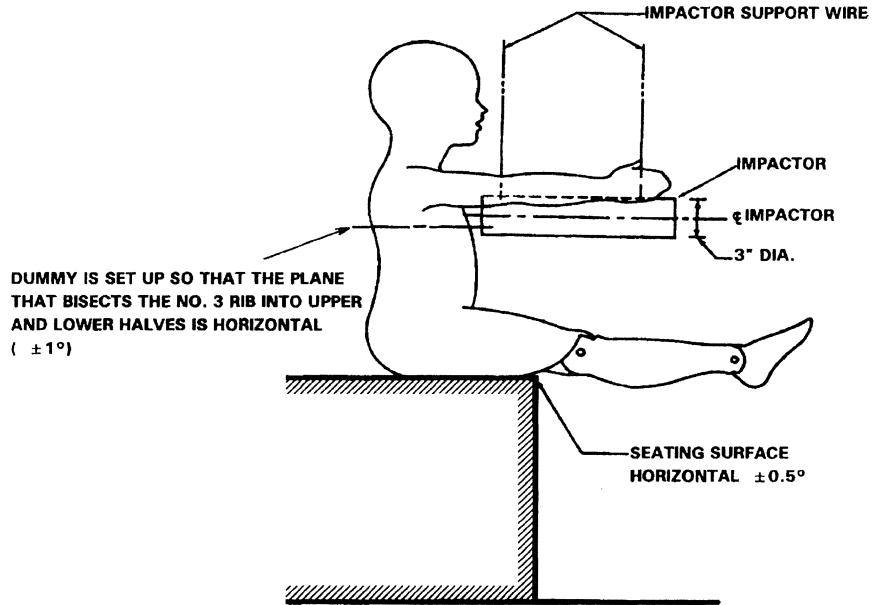
FIGURE 40
HEAD IMPACT TEST SET-UP

43



- NOTES: 1. DUMMY IMPACT SENSORS NOT USED IN THIS TEST MAY BE REPLACED BY EQUIVALENT DEAD WEIGHTS.
2. NO EXTERNAL SUPPORTS ARE REQUIRED ON THE DUMMY TO MEET SET-UP SPECIFICATIONS.
3. THE MIDSAGITTAL PLANE OF THE DUMMY IS VERTICAL WITHIN ± 1 DEG.
4. THE MIDSAGITTAL PLANE OF THE HEAD IS CENTERED WITH RESPECT TO THE LONGITUDINAL CENTERLINE OF THE PENDULUM WITHIN 0.12 IN.

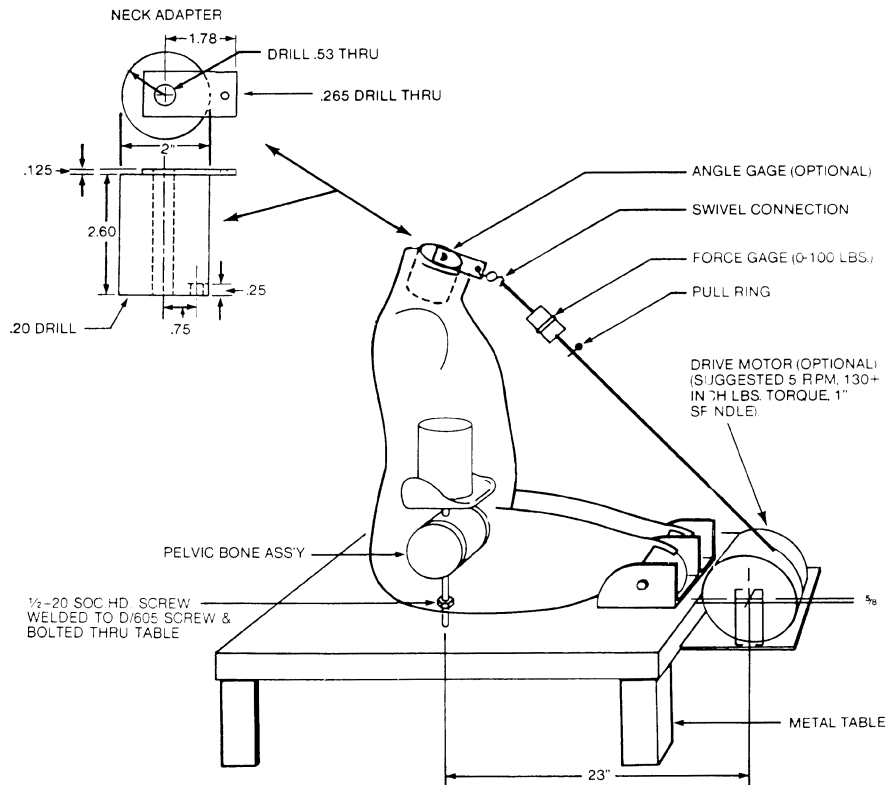
FIGURE 41
THORAX IMPACT TEST SET-UP



- NOTES:
1. DUMMY IMPACT SENSORS NOT USED IN THIS TEST MAY BE REPLACED BY EQUIVALENT DEAD WEIGHTS.
 2. NO EXTERNAL SUPPORTS ARE REQUIRED ON THE DUMMY TO MEET SET-UP SPECIFICATIONS.
 3. THE MIDSAGITTAL PLANE OF THE DUMMY IS VERTICAL WITHIN ± 1 DEG.
 4. THE MIDSAGITTAL PLANE OF THE THORAX IS CENTERED WITH RESPECT TO THE LONGITUDINAL CENTERLINE OF THE PENDULUM WITHIN 0.12 IN.

[60 F.R. 2898, Jan. 12, 1995]

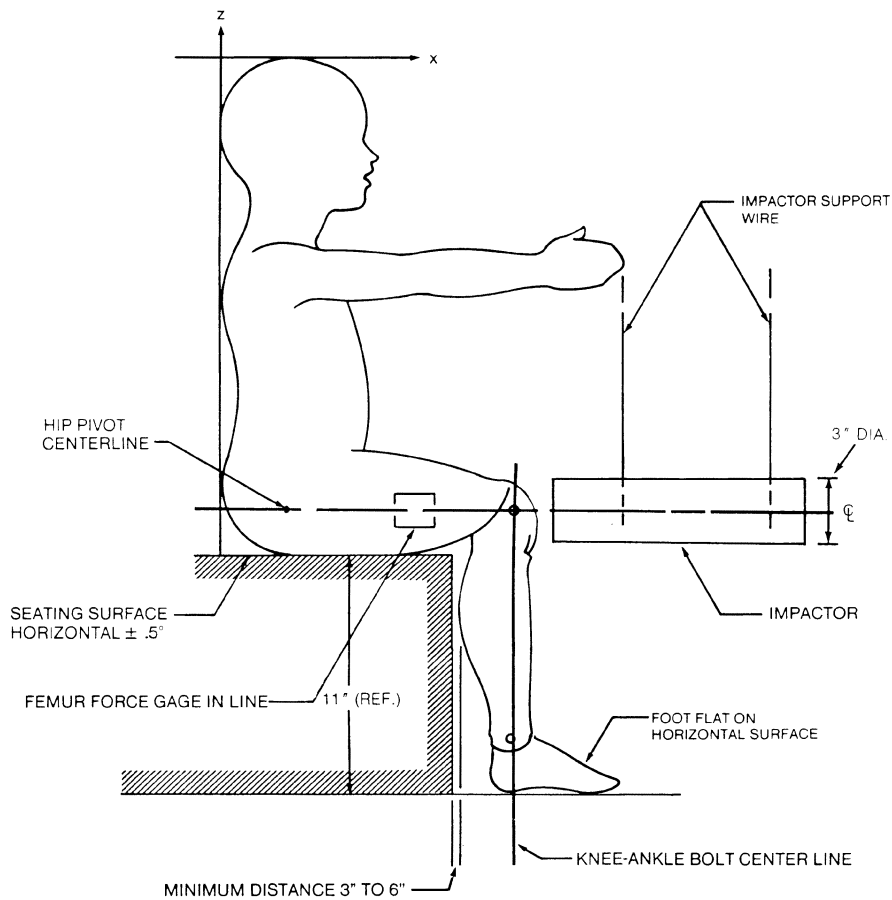
FIGURE 42
LUMBAR SPINE FLEXION TEST SET-UP



- NOTES: 1. DUMMY IMPACT SENSORS NOT USED IN THIS TEST MAY BE REPLACED BY EQUIVALENT DEAD WEIGHTS.
2. NO EXTERNAL SUPPORTS ARE REQUIRED ON THE DUMMY TO MEET SET-UP SPECIFICATIONS.
3. THE MIDSAGITTAL PLANE OF THE DUMMY IS VERTICAL WITHIN ± 1 DEG.
4. THE DUMMY IN THE SEATED POSITION IS FIRMLY AFFIXED TO THE TEST BENCH AT THE PELVIC BONE AND AT THE KNEES.
5. THE PULL-FLEXION FORCE, APPLIED THROUGH A RIGID NECK ADAPTOR WHICH IS MOUNTED ON TOP OF THE THORACIC STERNUM ASSEMBLY (C/601), IS ALIGNED WITH THE MIDSAGITTAL PLANE OF THE DUMMY WITHIN ± 1 DEG.
6. THE SWIVEL FOR THE FORCE MEASURING SENSOR MUST NOT BIND OR BOTTOM OUT THROUGH THE ENTIRE LOADING CYCLE.

FIGURE 43
KNEE IMPACT TEST SET-UP

46



- NOTES: 1. DUMMY IMPACT SENSORS NOT USED IN THIS TEST MAY BE REPLACED BY EQUIVALENT DEAD WEIGHTS.
2. NO EXTERNAL SUPPORTS ARE REQUIRED ON THE DUMMY TO MEET SET-UP SPECIFICATIONS.
3. THE MIDSAGITTAL PLANE OF THE DUMMY IS VERTICAL WITHIN ± 1 DEG.
4. CENTERLINE OF THE IMPACTED FEMUR IS ALIGNED WITH THE CENTERLINE OF THE IMPACTOR AND THE PLANE OF THE IMPACTOR MOTION WITHIN ± 1 DEG.

Subpart J—9-Month Old Child

§ 572.80 Incorporated materials.

SOURCE: 56 FR 41080, Aug. 19, 1991, unless otherwise noted.

The drawings and specifications referred to in § 572.81(a) that are not set forth in full are hereby incorporated in

this part by reference. These materials are thereby made part of this regulation. The Director of the Federal Register approved the materials incorporated by reference in accordance with 5 U.S.C. 552(a) and 1 CFR part 51. Copies of the materials may be obtained from Rowley-Scher Reprographics, Inc., 1216 K Street, NW., Washington, DC 20002, telephone (202) 628-6667. Copies are available for inspection in the general reference section of Docket 89-11, Docket Section, National Highway Traffic Safety Administration, room 5109, 400 Seventh Street, SW., Washington, DC, or at the National Archives and Records Administration (NARA). For information on the availability of this material at NARA, call 202-741-6030, or go to: http://www.archives.gov/federal_register/code_of_federal_regulations/ibr_locations.html.

§ 572.81 General description.

(a) The dummy consists of: (1) The assembly specified in drawing LP 1049/A, March 1979, which is described in its entirety by means of approximately 54 separate drawings and specifications, 1049/1 through 1049/54; and (2) a parts list LP 1049/0 (5 sheets); and (3) a report entitled, "The TNO P3/4 Child Dummy Users Manual," January 1979, published by Instituut voor Wegtransportmiddelen TNO.

(b) Adjacent dummy segments are joined in a manner such that throughout the range of motion and also under simulated crash-impact conditions there is no contact between metallic elements except for contacts that exist under static conditions.

(c) The structural properties of the dummy are such that the dummy conforms to this part in every respect both before and after being used in dynamic tests such as that specified in Standard No. 213 of this chapter (§ 571.213).

§ 572.82 Head.

The head consists of the assembly shown in drawing LP 1049/A and conforms to each of the applicable drawings listed under LP 1049/0 through 54.

§ 572.83 Head-neck.

The head-neck assembly shown in drawing 1049/A consists of parts speci-

fied as items 1 through 16 and in item 56.

§ 572.84 Thorax.

The thorax consists of the part of the torso shown in assembly drawing LP 1049/A and conforms to each of the applicable drawings listed under LP 1049/0 through 54.

§ 572.85 Lumbar spine flexure.

(a) When subjected to continuously applied force in accordance with paragraph (b) of this section, the lumbar spine assembly shall flex by an amount that permits the thoracic spine to rotate from its initial position in accordance with Figure No. 18 of § 572.21 (49 CFR part 572) by 40 degrees at a force level of not less than 18 pounds and not more than 22 pounds, and straighten upon removal of the force to within 5 degrees of its initial position.

(b) *Test procedure.* (1) The lumbar spine flexure test is conducted on a dummy assembly as shown in drawing LP 1049/A, but with the arms (which consist of parts identified as items 17 through 30) and all head-neck parts (identified as items 1 through 13 and 59 through 63), removed.

(2) With the torso assembled in an upright position, adjust the lumbar cable by tightening the adjustment nut for the lumbar vertebrae until the spring is compressed to $\frac{3}{8}$ of its unloaded length.

(3) Position the dummy in an upright seated position on a seat as indicated in Figure No. 18 of § 572.21 (lower legs do not need to be removed, but must be clamped firmly to the seating surface), ensuring that all dummy component surfaces are clean, dry and untreated unless otherwise specified.

(4) Firmly affix the dummy to the seating surface through the pelvis at the hip joints by suitable clamps that also prevent any relative motion with respect to the upper legs during the test in § 572.65(c)(3) of this part. Install a pull attachment at the neck to torso juncture as shown in Figure 18 of § 572.21.

(5) Flex the thorax forward 50 degrees and then rearward as necessary to return it to its initial position.

(6) Apply a forward pull force in the midsagittal plane at the top of the

§ 572.86

neck adapter so that at 40 degrees of the lumbar spine flexion the applied force is perpendicular to the thoracic spine box. Apply the force at any torso deflection rate between 0.5 and 1.5 degrees per second up to 40 degrees of flexion but no further; maintain 40 degrees of flexion for 10 seconds, and record the highest applied force during that time. Release all force as rapidly as possible and measure the return angle three minutes after release.

§ 572.86 Test conditions and dummy adjustment.

(a) With the complete torso on its back lying on a horizontal surface and the neck assembly mounted and shoulders on the edge of the surface, adjust the neck such that the head bolt is lowered 0.40 ±0.05 inches (10 ±1 mm) after a vertically applied load of 11.25 pounds (50 N) applied to the head bolt is released.

(b) With the complete torso on its back with the adjusted neck assembly as specified in § 572.66(a), and lying on a horizontal surface with the shoulders on the edge of the surface, mount the head and tighten the head bolt and nut firmly, with the head in horizontal position. Adjust the head joint at the force between 1–2g, which just supports the head's weight.

(c) Using the procedures described below, limb joints are set at the force between 1–2g, which just supports the limbs' weight when the limbs are extended horizontally forward:

(1) With the complete torso lying with its front down on a horizontal surface, with the hip joint just over the edge of the surface, mount the upper leg and tighten hip joint nut firmly. Adjust the hip joint by releasing the hip joint nut until the upper leg just starts moving.

(2) With the complete torso and upper leg lying with its front up on a horizontal surface, with the knee joint just over the edge of the surface, mount the lower leg and tighten knee joint firmly. Adjust the knee joint by releasing the knee joint nut until the lower leg just starts moving.

(3) With the torso in an upright position, mount the upper arm and tighten firmly the adjustment bolts for the shoulder joint with the upper arm

49 CFR Ch. V (10–1–10 Edition)

placed in a horizontal position. Adjust the shoulder joint by releasing the shoulder joint nut until the upper arm just starts moving.

(4) With the complete torso in an upright position and upper arm in a vertical position, mount the forearm in a horizontal position and tighten the elbow hinge bolt and nut firmly. Adjust the elbow joint nut until the forearm just starts moving.

(d) With the torso assembled in an upright position, the adjustment nut for the lumbar vertebrae is tightened until the spring is compressed to ⅔ of its unloaded length.

(e) Performance tests are conducted at any temperature from 66 to 78 degrees F and at any relative humidity from 10 percent to 70 percent after exposure of the dummy to these conditions for a period of not less than four hours.

(f) Performance tests of the same component, segment, assembly or fully assembled dummy are separated in time by a period of not less than 20 minutes unless otherwise specified.

(g) Surfaces of the dummy components are not painted except as specified in the part or in drawings incorporated by this part.

Subpart K—Newborn Infant

SOURCE: 58 FR 3232, Jan. 8, 1993, unless otherwise noted.

§ 572.90 Incorporation by reference.

(a) The drawings and specifications referred to in § 572.91(a) are hereby incorporated in subpart K by reference. These materials are thereby made part of this regulation. The Director of the Federal Register approved that materials incorporated by reference in accordance with 5 U.S.C. 552(a) and 1 CFR part 51. Copies of the materials may be inspected at NHTSA's Docket Section, 400 Seventh Street, SW., room 5109, Washington, DC, or at the National Archives and Records Administration (NARA). For information on the availability of this material at NARA, call 202-741-6030, or go to: http://www.archives.gov/federal_register/code_of_federal_regulations/ibr_locations.html.

(b) The incorporated material is available as follows:

(1) Drawing numbers 126-0000 through 126-0015 (sheets 1 through 3), 126-0017 through 126-0027, and a parts list entitled "Parts List for CAMI Newborn Dummy," are available from Reprographic Technologies, 1111 14th Street, NW., Washington, DC 20005. (202) 628-6667.

(2) A construction manual entitled, "Construction of the Newborn Infant Dummy" (July 1992) is available from Reprographic Technologies at the address in paragraph (b)(1) of this section.

§ 572.91 General description.

(a) The representative newborn infant dummy consists of a drawings and specifications package that contains the following materials:

(1) Drawing numbers 126-0000 through 126-0015 (sheets 1 through 3), 126-0017 through 126-0027, and a parts list entitled "Parts List for CAMI Newborn Dummy"; and,

(2) A construction manual entitled, "Construction of the Newborn Infant Dummy" (July 1992).

(b) The structural properties of the dummy are such that the dummy conforms to this part in every respect both before and after being used in dynamic tests specified in Standard No. 213 of this chapter (§ 571.213).

Subpart L—Free Motion Headform

SOURCE: 60 FR 43058, Aug. 18, 1995, unless otherwise noted.

§ 572.100 Incorporation by Reference.

(a) The drawings and specifications referred to in § 572.101 are hereby incorporated in subpart L by reference. These materials are thereby made part of this regulation. The Director of the Federal Register approved the materials incorporated by reference in accordance with 5 U.S.C. 552(a) and 1 CFR part 51. Copies of the materials may be inspected at NHTSA's Docket Section, 400 Seventh Street, S.W., room 5109, Washington, DC, or at the National Archives and Records Administration (NARA). For information on the availability of this material at NARA, call 202-741-6030, or go to: http://www.archives.gov/federal_register/

code_of_federal_regulations/ibr_locations.html.

(b) The incorporated material is available as follows:

(1) Drawing number 92041-001, "Head Form Assembly," (November 30, 1992); drawing number 92041-002, "Skull Assembly," (November 30, 1992); drawing number 92041-003, "Skull Cap Plate Assembly," (November 30, 1992); drawing number 92041-004, "Skull Cap Plate," (November 30, 1992); drawing number 92041-005, "Threaded Pin," (November 30, 1992); drawing number 92041-006, "Hex Nut," (November 30, 1992); drawing number 92041-008, "Head Skin without Nose," (November 30, 1992, as amended March 6, 1995); drawing number 92041-009, "Six-Axis Load Cell Simulator Assembly," (November 30, 1992); drawing number 92041-011, "Head Ballast Weight," (November 30, 1992); drawing number 92041-018, "Head Form Bill of Materials," (November 30, 1992); drawing number 78051-148, "Skull-Head (cast) Hybrid III," (May 20, 1978, as amended August 17, 1978); drawing number 78051-228/78051-229, "Skin-Hybrid III," (May 20, 1978, as amended through September 24, 1979); drawing number 78051-339, "Pivot Pin-Neck Transducer," (May 20, 1978, as amended May 14, 1986); drawing number 78051-372, "Vinyl Skin Formulation Hybrid III," (May 20, 1978); and drawing number C-1797, "Neck Blank, (August 1, 1989); drawing number SA572-S4, "Accelerometer Specification," (November 30, 1992), are available from Reprographic Technologies, 1111 14th Street, N.W., Washington, DC 20005.

(2) A user's manual entitled "Free-Motion Headform User's Manual," version 2, March 1995, is available from NHTSA's Docket Section at the address in paragraph (a) of this section.

(3) SAE Recommended Practice J211, OCT 1988, "Instrumentation for Impact Tests," Class 1000, is available from The Society of Automotive Engineers, Inc., 400 Commonwealth Drive, Warrendale, PA 15096.

§ 572.101 General description.

(a) The free motion headform consists of the component assembly which is shown in drawings 92041-001 (incorporated by reference; see § 572.100), 92041-002 (incorporated by reference;

§ 572.102

see § 572.100), 92041-003 (incorporated by reference; see § 572.100), 92041-004 (incorporated by reference; see § 572.100), 92041-005 (incorporated by reference; see § 572.100), 92041-006 (incorporated by reference; see § 572.100), 92041-008 (incorporated by reference; see § 572.100), 92041-009 (incorporated by reference; see § 572.100), 92041-011 (incorporated by reference; see § 572.100), 78051-148 (incorporated by reference; see § 572.100), 78051-228/78051-229 (incorporated by reference; see § 572.100), 78051-339 (incorporated by reference; see § 572.100), 78051-372 (incorporated by reference; see § 572.100), C-1797 (incorporated by reference; see § 572.100), and SA572-S4 (incorporated by reference; see § 572.100).

(b) Disassembly, inspection, and assembly procedures, and sign convention for the signal outputs of the free motion headform accelerometers, are set forth in the Free-Motion Headform User's Manual (incorporated by reference; see § 572.100).

(c) The structural properties of the headform are such that it conforms to this part in every respect both before and after being used in the test specified in Standard No. 201 of this chapter (§ 571.201).

(d) The outputs of accelerometers installed in the headform are recorded in individual data channels that conform to the requirements of SAE Recommended Practice J211, OCT 1988, "Instrumentation for Impact Tests," Class 1000 (incorporated by reference; see § 572.100).

§ 572.102 Drop test.

(a) When the headform is dropped from a height of 14.8 inches in accordance with paragraph (b) of this section, the peak resultant accelerations at the location of the accelerometers mounted in the headform as shown in drawing 92041-001 (incorporated by reference; see § 572.100) shall not be less than 225g, and not more than 275g. The acceleration/time curve for the test shall be unimodal to the extent that oscillations occurring after the main acceleration pulse are less than ten percent (zero to peak) of the main pulse. The lateral acceleration vector shall not exceed 15g (zero to peak).

49 CFR Ch. V (10-1-10 Edition)

(b) *Test procedure.* (1) Soak the headform in a test environment at any temperature between 19 degrees C. to 26 degrees C. and at a relative humidity from 10 percent to 70 percent for a period of at least four hours prior to its use in a test.

(2) Clean the headform's skin surface and the surface of the impact plate with 1,1,1 Trichloroethane or equivalent.

(3) Suspend the headform, as shown in Figure 50. Position the forehead below the chin such that the skull cap plate is at an angle of 28.5 ± 0.5 degrees with the impact surface when the midsagittal plane is vertical.

(4) Drop the headform from the specified height by means that ensure instant release onto a rigidly supported flat horizontal steel plate, which is 2 inches thick and 2 feet square. The plate shall have a clean, dry surface and any microfinish of not less than 8 microinches 203.2×10^{-6} mm (rms) and not more than 80 microinches 2032×10^{-6} mm (rms).

(5) Allow at least 3 hours between successive tests on the same headform.

§ 572.103 Test conditions and instrumentation.

(a) Headform accelerometers shall have dimensions, response characteristics, and sensitive mass locations specified in drawing SA572-S4 (incorporated by reference; see § 572.100) and be mounted in the headform as shown in drawing 92041-001 (incorporated by reference; see § 572.100).

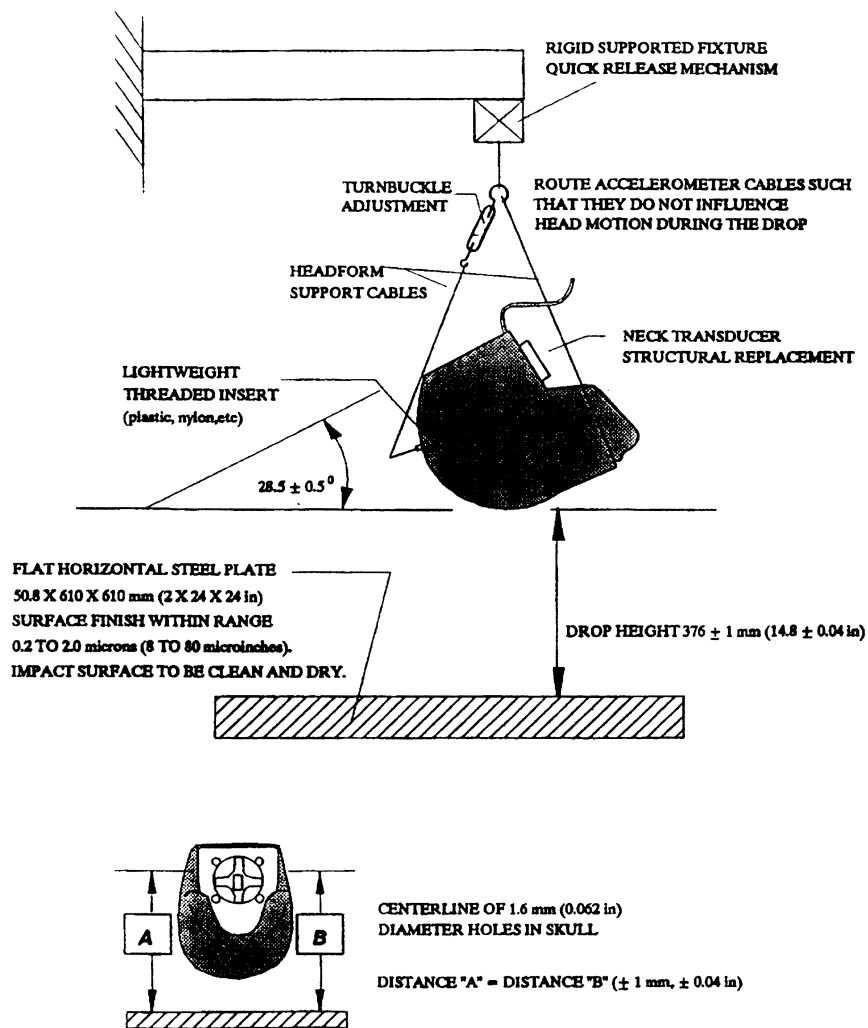
(b) The outputs of accelerometers installed in the headform are recorded in individual data channels that conform to the requirements of SAE Recommended Practice J211, OCT 1988, "Instrumentation for Impact Tests," Class 1000 (incorporated by reference; see § 572.100).

(c) Coordinate signs for instrumentation polarity conform to the sign convention shown in the Free-Motion Headform User's Manual (incorporated by reference; see § 572.100).

(d) The mountings for accelerometers shall have no resonant frequency within a range of 3 times the frequency range of the applicable channel class.

Figure 50

**HEADFORM DROP TEST
Set-Up Specifications**



[60 FR 43060, Aug. 18, 1995]

Subpart M—Side Impact Hybrid Dummy 50th Percentile Male

SOURCE: 63 FR 41470, Aug. 4, 1998, unless otherwise noted.

§ 572.110 Materials incorporated by reference.

(a) The following materials are hereby incorporated by reference in Subpart M:

(1) The Anthropomorphic Test Dummy Parts List, SID/Hybrid III part 572, subpart M, dated May 10, 1997.

(2) The SID/Hybrid III Part 572 Subpart M User's Manual, dated May 1997.

(3) Drawing number 96-SIDH3-001, titled, "Head-Neck Bracket," dated August 30, 1996.

(4) Drawing number 96-SIDH3-006, titled, "Upper and Middle Shoulder Foam," dated May 10, 1997.

(5) Drawing number SA-SIDH3-M001, titled, "Complete Assembly SIDH3," dated April 19, 1997.

(6) Drawing number 78051-61X, Revision C, titled "Head Assembly—complete," dated March 28, 1997.

(7) Drawing number 78051-90, Revision A, titled "Neck Assembly—complete," dated May 20, 1978.

(8) Dummy assembly drawing number SA-SID-M030, Revision A, titled "Thorax Assembly—complete," dated May 18, 1994.

(9) Dummy assembly drawing SA-SID-M050, revision A, titled "Lumbar Spine Assembly," dated May 18, 1994.

(10) Dummy assembly drawing SA-150 M060, revision A, titled "Pelvis and Abdomen Assembly," dated May 18, 1994.

(11) Dummy assembly drawing SA-SID-053, revision A, titled "Lumbar Spine Assembly," dated May 18, 1994.

(12) Dummy assembly drawing SA-SID-M080, titled "Leg Assembly, Right," dated August 13, 1987.

(13) Dummy assembly drawing SA-SID-M081, titled "Leg Assembly, Left," dated August 13, 1987.

(14) Drawing number 78051-383X, Revision P, titled "Neck Transducer Structural Replacement," dated November 1, 1995.

(15) The Society of Automotive Engineers (SAE) J1733 Information Report, titled "Sign Convention for Vehicle Crash Testing," dated December 1994.

(16) SAE Recommended Practice J211, "Instrumentation for Impact Tests," Parts 1 and 2, dated March 1995.

(b) The incorporated materials are available as follows:

(1) The Director of the Federal Register approved those materials incorporated by reference in accordance with 5 U.S.C. 552(a) and 1 CFR part 51. Copies of the materials may be inspected at NHTSA's Docket Section, 400 Seventh Street S.W., room 5109, Washington, DC, or at the National Archives and Records Administration (NARA). For information on the availability of this material at NARA, call 202-741-6030, or go to: http://www.archives.gov/federal_register/code_of_federal_regulations/ibr_locations.html.

(2) The parts lists, user's manual and drawings referred to in paragraphs (a)(1) through (a)(14) of this section are available from Reprographic Technologies, 9000 Virginia Manor Road, Beltsville, MD 20705 (301) 419-5070.

(3) The SAE materials referred to in paragraphs (a)(15) and (a)(16) of this section are available from the Society of Automotive Engineers, Inc., 400 Commonwealth Drive, Warrendale, PA 15096.

§ 572.111 General description.

(a) The dummy consists of component parts and component assemblies defined in drawing SA-SIDH3-M001, dated April 19, 1997, which are described in approximately 200 drawings and specifications that are set forth in §§ 572.32, 572.33 and 572.41(a)(3),(4),(5) and (6) of this part, and in the drawing of the Adaptor Bracket 96-SIDH3-001.

(1) The head assembly consists of the assembly specified in subpart E (§ 572.32) and conforms to each of the drawings subtended under drawing 78051-61X rev. C.

(2) The neck assembly consists of the assembly specified in subpart E (§ 572.33) and conforms to each of the drawings subtended under drawing 78051-90 rev. A.

(3) The thorax assembly consists of the assembly shown as number SID 053 and conforms to each applicable drawing subtended by number SA-SID M030 rev. A.

(4) The lumbar spine consists of the assembly specified in subpart B (§572.9(a)) and conforms to drawing SA 150 M050 and drawings subtended by SA-SID M050 rev. A.

(5) The abdomen and pelvis consist of the assembly and conform to the drawings subtended by SA 150 M060, the drawings subtended by SA 150 M060 rev. A and the drawings subtended by SA-SID-087 sheet 1 rev. H, and SA-SID-87 sheet 2 rev. H.

(6) The lower limbs consist of the assemblies specified in Subpart B (§572.10) shown as SA 150 M080 and SA 150 M081 in Figure 1 and SA-SID-M080 and SA-SID-M081 and conform to the drawings subtended by those numbers.

(7) The neck mounting adaptor bracket conforms to drawing 96-SIDH3-001.

(8) Upper and middle shoulder foams conform to drawing 96-SIDH3-006.

(b) The structural properties of the dummy are such that the dummy conforms to the specifications of this subpart in every respect before being used in vehicle tests specified in Standard 201.

(c) Disassembly, inspection and assembly procedures, external dimensions, weight and drawing list are set forth in the SIDH3 User's Manual, dated May 1997.

(d) Sign convention for signal outputs is given in the reference document SAE J1733 of 1994-12, "Sign Convention for Vehicle Crash Testing."

§572.112 Head assembly.

The head assembly consists of the head (drawing 78051-61X, rev. C) with the neck transducer structural replacement (drawing 78051-383X, rev. P) and three (3) accelerometers that are mounted in conformance to §572.36 (c).

(a) Test procedure. (1) Soak the head assembly in a test environment at any temperature between 18.9 and 25.6 degrees C. (66 to 78 degrees F.) and at a relative humidity between 10 percent and 70 percent for a period of at least four (4) hours prior to its application in a test.

(2) Clean the impact surface of the head skin and impact plate surface, described in paragraph (a)(4) of this section, with 1,1,1 trichloroethane or equivalent prior to the test.

(3) Suspend the head, as shown in Figure 51, so that the midsagittal plane makes an angle of 35 ± 1 degrees with the impact surface and its anterior-posterior axis is horizontal ± 1 degree.

(4) Drop the head from a height of 200 ± 0.25 mm (7.87 ± 0.01 inches), measured from the lowest point on the head, by a means that ensures a smooth, clean release into a rigidly supported flat horizontal steel plate, which is 51 ± 2 mm (2.0 ± 0.01 in.) thick and 610 ± 10 mm (24.0 ± 0.4 in) square. The plate shall have a dry surface and shall have a microfinish of 0.2 microns (8 microinches) to 2.0 microns (80 microinches).

(5) Allow at least two (2) hours between successive tests on the same head.

(b) Performance criteria. (1) When the head assembly is dropped in accordance with §572.112(a), the measured peak resultant acceleration shall be between 120 and 150 G's.

(2) The resultant acceleration-time curve shall be unimodal to the extent that oscillations occurring after the main acceleration pulse shall not exceed 15 percent (zero to peak) of the main pulse. The longitudinal acceleration vector shall not exceed 15 G's.

Figure 51
HEAD DROP TEST

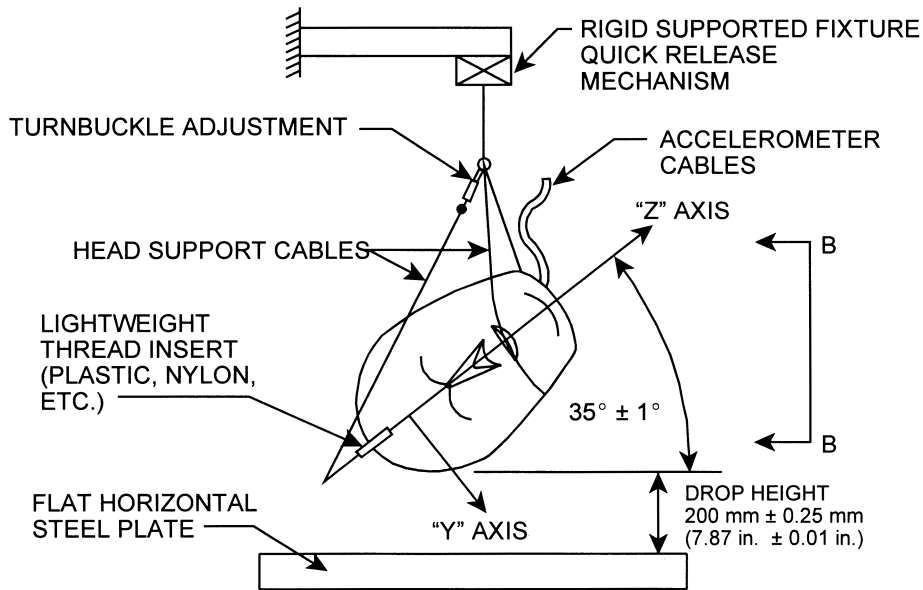
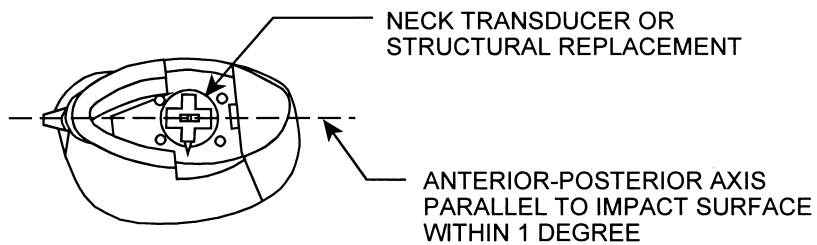


Plate is 51 mm x 610 mm x 610 mm (2 x 24 x 24 in.) with SURFACE FINISH 0.2 microns (8 microinches) to 2.0 microns (80 microinches). IMPACT SURFACE to be clean and dry.



VIEW B-B

§ 572.113 Neck assembly.

The head/neck assembly consists of the parts 78051-61X, rev. C; -84; -90, rev. A; -94; -98; -104, revision F; -303, rev.

E; -305; -306; -307, rev. X and has a six axis neck transducer (drawing C-1709, revision D) installed in conformance with § 572.36(d).

(a) Test procedure. (1) Soak the head and neck assembly in a test environment at any temperature between 20.6 and 22.2 degrees C. (69 to 72 degrees F.) and at any relative humidity between 10 percent and 70 percent for a period of at least four (4) hours prior to its application in a test.

(2) Torque the jamnut (78051-64) on the neck cable (78051-301, rev. E) to 1.35 ±0.27 Nm (1.0 ±0.2 ft-lb) before each test.

(3) Using neck brackets 78051-303 and -307, mount the head/neck assembly to the part 572 pendulum test fixture (see §572.33, Figure 22,) so that the midsagittal plane of the head is vertical and perpendicular to the plane of motion of the pendulum's longitudinal centerline (see §572.33, Figure 20, except that the direction of the head/neck assembly is rotated around the superior-inferior axis by an angle of 90 degrees). Install suitable transducers or other devices necessary for measuring the "D" plane (horizontal surface at the base of the skull) rotation with respect to the pendulum's longitudinal centerline. The rotation can be measured by placing a transducer at the occipital condyles and another at the intersection of the centerline of the neck and the line extending from the base of the neck as shown in figure 52.

(4) Release the pendulum and allow it to fall freely from a height to achieve an impact velocity of 6.89 to 7.13 m/s (22.6 to 23.4 ft/sec) measured at the center of the pendulum accelerometer.

(5) Allow the neck to flex without the head or neck contacting any object during the test.

(6) Time zero is defined as the time of initial contact between the striker plate and the pendulum deceleration medium.

(7) Allow a period of at least thirty (30) minutes between successive tests on the same neck assembly.

(b) Performance criteria. (1) The pendulum deceleration pulse is to be characterized in terms of decrease in veloc-

ity as obtained by integrating the pendulum acceleration output.

Time (ms)	Pendulum Delta-V (m/s)
10	1.96 to 2.55.
20	4.12 to 5.10.
30	5.73 to 7.01.
40 to 70	6.27 to 7.64.

(2) The maximum rotation of the midsagittal plane of the head shall be 66 to 82 degrees with respect to the pendulum's longitudinal centerline. The decaying head rotation vs. time curve shall cross the zero angle between 58 to 67 ms after reaching its peak value.

(3) The moment about the x-axis which coincides with the midsagittal plane of the head at the level of the occipital condyles shall have a maximum value between 73 and 88 Nm. The decaying moment vs. time curve shall first cross zero moment between 49 and 64 ms after reaching its peak value. The following formula is to be used to calculate the moment about the occipital condyles when using the six-axis neck transducer:

$$M = Mx + 0.01778 Fy$$

Where Mx and Fy are the moment and force measured by the transducer and expressed in terms of Nm and N, respectively.

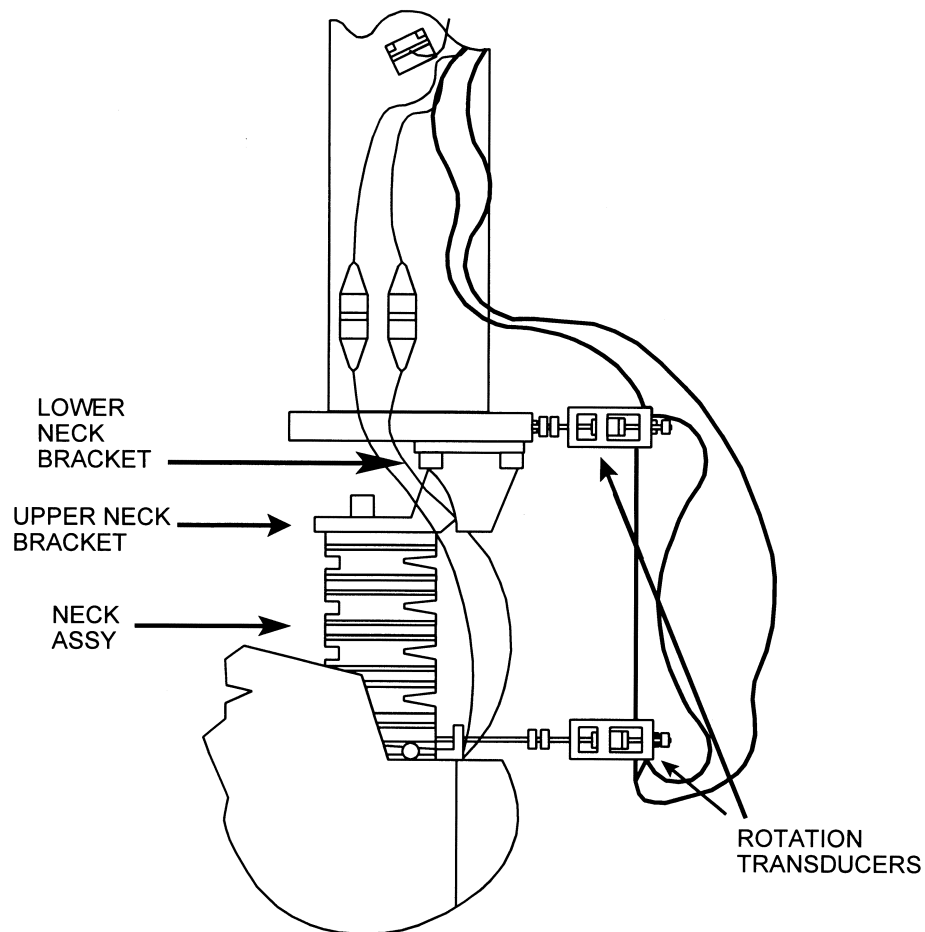
(4) The maximum rotation of the head with respect to the pendulum's longitudinal centerline shall occur between 2 and 16 ms after peak moment.

[63 FR 41470, Aug. 4, 1998, as amended at 66 FR 51882, Oct. 11, 2001]

§ 572.114 Thorax.

The specifications and test procedure for the thorax for the SID/HIII dummy are identical to those applicable to the SID dummy as set forth in §572.42 except that the reference to the SID device found in §572.42(a), (SA-SID-M001A revision A, dated May 18, 1994) does not apply and the reference to the SID/HIII (SA-SIDH3-M001, dated April 19, 1997) is applied in its place.

Figure 52
NECK PENDULUM TEST



§ 572.115 Lumbar spine and pelvis.

The specifications and test procedure for the lumbar spine and pelvis are identical to those for the SID dummy as set forth in § 572.42 except that the reference to the SID device found in § 572.42(a), (SA-SID-M001A revision A, dated May 18, 1994) does not apply and the reference to the SID/HIII (SA-

SIDH3-M001, dated April 19, 1997) is applied in its place.

§ 572.116 Instrumentation and test conditions.

(a) The test probe for lateral thoracic and pelvis impact tests are the same as those specified in § 572.44(a).

(b) Accelerometer mounting in the thorax is the same as specified in § 572.44(b).

(c) Accelerometer mounting in the pelvis is the same as specified in § 572.44(c).

(d) Head accelerometer mounting is the same as specified in § 572.36(c).

(e) Neck transducer mounting is the same as specified in § 572.36(d).

(f) Instrumentation and sensors used must conform to SAE Recommended Practice J211, March 1995, "Instrumentation for Impact Tests."

(g) The mountings for the spine, rib and pelvis accelerometers shall have no resonance frequency within a range of 3 times the frequency range of the applicable channel class.

(h) Limb joints of the test dummy shall be set at the force between 1 to 2 g's, which just supports the limb's weight when the limbs are extended horizontally forward. The force required to move a limb segment does not exceed 2 g's throughout the range of the limb motion.

(i) Performance tests must be conducted at a temperature between 20.6 and 22.2 degrees C. (69 to 72 degrees F.) and at a relative humidity between 10 percent and 70 percent after exposure of the dummy to those conditions for a period of at least four (4) hours.

(j) For the performance of tests specified in § 572.114 and § 572.115, the dummy is positioned the same as specified in § 572.44(h).

(iii) Drawing No. 127-2000, Upper Torso Assembly,

(iv) Drawing No. 127-3000, Lower Torso Assembly,

(v) Drawing No. 127-4000-1 and 4000-2, Leg Assembly,

(vi) Drawing No. 127-5000-1 and 5000-2, Arm Assembly, and

(vii) The Hybrid III Six-year-old Child Parts/Drawing List.

(2) A procedures manual entitled "Procedures for Assembly, Disassembly, and Inspection (PADI) of the Hybrid III 6-year-old Child Crash Test Dummy (H-III6C), Beta Version, June 2002";

(3) SAE Recommended Practice J211-1995 Instrumentation for Impact Tests—Parts 1 and 2, dated March, 1995";

(4) SAE J1733 Information Report, titled "Sign Convention for Vehicle Crash Testing", dated December 1994.

(b) The Director of the Federal Register approved those materials incorporated by reference in accordance with 5 U.S.C. 552(a) and 1 CFR part 51. Copies of the materials may be inspected at NHTSA's Technical Reference Library, 400 Seventh Street SW., room 5109, Washington, DC, or at the National Archives and Records Administration (NARA). For information on the availability of this material at NARA, call 202-741-6030, or go to: http://www.archives.gov/federal_register/code_of_federal_regulations/ibr_locations.html.

(c) The incorporated materials are available as follows:

(1) The drawings and specifications package and the PADI document referred to in subparagraph (a) are accessible for viewing and copying at the Department of Transportation Docket's public area, Plaza 401, 400 Seventh St., SW., Washington, DC 20590, and may be downloaded from dms.dot.gov. They are also available from Reprographic Technologies, 9107 Gaither Rd, Gaithersburg, MD 200877, (301) 419-5070.

(2) The SAE materials referred to in paragraphs (a)(3) and (a)(4) of this section are available from the Society of

Subpart N—Six-year-old Child Test Dummy, Beta Version

SOURCE: 65 FR 2065, Jan. 13, 2000, unless otherwise noted.

§ 572.120 Incorporation by reference.

(a) The following materials are hereby incorporated into this subpart by reference:

(1) A drawings and inspection package entitled "Parts List and Drawings, Hybrid III Six-year-old Child Test Dummy (H-III6C, Beta Version) (June 2002)", consisting of:

(i) Drawing No. 127-1000, 6-year H3 Head Complete,

(ii) Drawing No. 127-1015, Neck Assembly,

§572.121

Automotive Engineers, Inc., 400 Commonwealth Drive, Warrendale, PA 15096.

[65 FR 2065, Jan. 13, 2000, as amended at 67 FR 47327, July 18, 2002]

§572.121 General description.

(a) The Hybrid III type 6-year-old dummy is defined by drawings and specifications containing the following materials:

(1) Technical drawings and specifications package P/N 127-0000, the titles of which are listed in Table A;

(2) Procedures for Assembly, Disassembly, and Inspection (PADI) of the Hybrid III 6-year-old test dummy, Alpha version (August 1999).

TABLE A

Component assembly	Drawing number
Head assembly	127-1000
Neck assembly	127-1015
Upper torso assembly	127-2000
Lower torso assembly	127-3000
Leg assembly	127-4000
Arm assembly	127-5000

(b) Adjacent segments are joined in a manner such that except for contacts existing under static conditions, there is no contact between metallic elements throughout the range of motion or under simulated crash impact conditions.

(c) The structural properties of the dummy are such that the dummy must conform to this Subpart in every respect before use in any test similar to those specified in Standard 208, "Occupant Crash Protection", and Standard 213, "Child Restraint Systems".

§572.122 Head assembly and test procedure.

(a) The head assembly for this test consists of the complete head (drawing 127-1000), a six-axis neck transducer (drawing SA572-S11) or its structural replacement (drawing 78051-383X), a head to neck-to-pivot pin (drawing 78051-339), and 3 accelerometers (drawing SA572-S4).

(b) When the head assembly in paragraph (a) of this section is dropped from a height of 376.0 ±1.0 mm (14.8 ±0.04 in) in accordance with paragraph (c) of this section, the peak resultant acceleration at the location of the

49 CFR Ch. V (10-1-10 Edition)

accelerometers at the head CG may not be less than 245 G or more than 300 G. The resultant acceleration vs. time history curve shall be unimodal; oscillations occurring after the main pulse must be less than 10 percent of the peak resultant acceleration. The lateral acceleration shall not exceed 15 g's (zero to peak).

(c) *Head test procedure.* The test procedure for the head is as follows:

(1) Soak the head assembly in a controlled environment at any temperature between 18.9 and 25.6 °C (66 and 78 °F) and a relative humidity from 10 to 70 percent for at least four hours prior to a test.

(2) Prior to the test, clean the impact surface of the skin and the impact plate surface with isopropyl alcohol, trichloroethane, or an equivalent. The skin of the head must be clean and dry for testing.

(3) Suspend the head assembly as shown in Figure N1. The lowest point on the forehead must be 376.0 ±1.0 mm (14.8 ±0.04 in) from the impact surface and the head must be oriented to an incline of 62 ±1 deg. between the "D" plane as shown in Figure N1 and the plane of the impact surface. The 1.57 mm (0.062 in) diameter holes located on either side of the dummy's head shall be used to ensure that the head is level with respect to the impact surface.

(4) Drop the head assembly from the specified height by means that ensure a smooth, instant release onto a rigidly supported flat horizontal steel plate which is 50.8 mm (2 in) thick and 610 mm (24 in) square. The impact surface shall be clean, dry and have a micro finish of not less than 203.2. × 10⁻⁶ mm (8 micro inches) (RMS) and not more than 2032.0 × 10⁻⁶ mm (80 micro inches) (RMS).

(5) Allow at least 2 hours between successive tests on the same head.

§572.123 Neck assembly and test procedure.

(a) The neck assembly for the purposes of this test consists of the assembly of components shown in drawing 127-1015.

(b) When the head-neck assembly consisting of the head (drawing 127-1000), neck (drawing 127-1015), pivot pin (drawing 78051-339), bib simulator

(drawing TE127-1025, neck bracket assembly (drawing 127-8221), six-axis neck transducer (drawing SA572-S11), neck mounting adaptor (drawing TE-2208-001), and three accelerometers (drawing SA572-S4) installed in the head assembly as specified in §572.122, is tested according to the test procedure in paragraph (c) of this section, it shall have the following characteristics:

(1) *Flexion.* (i) Plane D, referenced in Figure N2, shall rotate in the direction of preimpact flight with respect to the pendulum's longitudinal centerline between 74 degrees and 92 degrees. Within this specified rotation corridor, the peak moment about the occipital condyles shall be not less than 27 N-m (19.9 ft-lbf) and not more than 33 N-m (24.3 ft-lbf).

(ii) The positive moment shall decay for the first time to 5 N-m (3.7 ft-lbf) between 103 ms and 123 ms.

(iii) The moment shall be calculated by the following formula: Moment (N-m) = $M_y - (0.01778m) \times (F_x)$.

(iv) M_y is the moment about the y-axis and F_x is the shear force measured by the neck transducer (drawing SA572-S11) and 0.01778m is the distance from force to occipital condyle.

(2) *Extension.* (i) Plane D, referenced in Figure N3, shall rotate in the direction of preimpact flight with respect to the pendulum's longitudinal centerline between 85 degrees and 103 degrees. Within this specified rotation corridor, the peak moment about the occipital condyles shall be not more than -19 N-m (-14 ft-lbf) and not less than -24 N-m (-17.7ft-lbf).

(ii) The negative moment shall decay for the first time to -5 N-m (-3.7 ft-lbf) between 123 ms and 147 ms.

(iii) The moment shall be calculated by the following formula: Moment (N-m) = $M_y - (0.01778m) \times (F_x)$.

(iv) M_y is the moment about the y-axis and F_x is the shear force measured

by the neck transducer (drawing SA572-S11) and 0.017778m is the distance from force to occipital condyle.

(3) Time-zero is defined as the time of initial contact between the pendulum striker plate and the honeycomb material.

(c) *Test procedure.* The test procedure for the neck assembly is as follows:

(1) Soak the neck assembly in a controlled environment at any temperature between 20.6 and 22.2 °C (69 and 72 °F) and a relative humidity between 10 and 70 percent for at least four hours prior to a test.

(2) Torque the jam nut (drawing 9000341) on the neck cable (drawing 127-1016) to 0.23 ±0.02 N-m (2.0 ±0.2 in-lbs).

(3) Mount the head-neck assembly, defined in paragraph (b) of this section, on the pendulum so the midsagittal plane of the head is vertical and coincides with the plane of motion of the pendulum as shown in Figure N2 for flexion tests and Figure N3 for extension tests.

(4) Release the pendulum and allow it to fall freely from a height to achieve an impact velocity of 4.95 ±0.12 m/s (16.2 ±0.4 ft/s) for flexion tests and 4.3 ±0.12 m/s (14.10 ±0.40 ft/s) for extension tests, measured by an accelerometer mounted on the pendulum as shown in Figure 22 of 49 CFR 572 at the instant of contact with the honey comb.

(i) Time-zero is defined as the time of initial contact between the pendulum striker plate and the honeycomb material. All data channels should be at the zero level at this time.

(ii) Stop the pendulum from the initial velocity with an acceleration vs. time pulse which meets the velocity change as specified below. Integrate the pendulum acceleration data channel to obtain the velocity vs. time curve:

TABLE B

Time ms	Pendulum pulse			
	Flexion		Extension	
	m/s	ft/s	m/s	ft/s
10	1.2-1.6	3.9-5.3	1.0-1.4	3.3-4.6
20	2.4-3.4	7.9-11.2	2.2-3.0	7.2-9.8
30	3.8-5.0	12.5-16.4	3.2-4.2	10.5-13.8

§ 572.124

49 CFR Ch. V (10–1–10 Edition)

§ 572.124 Thorax assembly and test procedure.

(a) *Thorax (upper torso) assembly.* The thorax consists of the part of the torso assembly shown in drawing 127–2000.

(b) When the anterior surface of the thorax of a completely assembled dummy (drawing 127–0000) is impacted by a test probe conforming to section 572.127(a) at 6.71 ± 0.12 m/s (22.0 ± 0.4 ft/s) according to the test procedure in paragraph (c) of this section:

(1) The maximum sternum displacement (compression) relative to the spine, measured with chest deflection transducer (drawing SA572-S50), must be not less than 38.0 mm (1.50 in) and not more than 46.0 mm (1.80 in). Within this specified compression corridor, the peak force, measured by the probe in accordance with section 572.127, shall not be less than 1150 N (259 lbf) and not more than 1380 N (310 lbf). The peak force after 12.5 mm (0.5 in) of sternum displacement but before reaching the minimum required 38.0 mm (1.5 in) sternum displacement limit shall not exceed 1500 N (337.2 lbf).

(2) The internal hysteresis of the ribcage in each impact as determined by the plot of force vs. deflection in paragraph (b)(1) of this section shall be not less than 65 percent but not more than 85 percent.

(c) *Test procedure.* The test procedure for the thorax assembly is as follows:

(1) Soak the dummy in a controlled environment at any temperature between 20.6° and 22.2 °C (69° and 72 °F) and a relative humidity between 10 and 70 percent for at least four hours prior to a test.

(2) Seat and orient the dummy, wearing tight-fitting underwear or equivalent consisting of a size 5 short-sleeved shirt having a weight less than 0.090 kg (0.2 lb) and an opening at the top just large enough to permit the passage of the head with a tight fit, and a size 4 pair of long pants having a weight of less than 0.090 kg (0.2 lb) with the legs cut off sufficiently above the knee to allow the knee target to be visible, on a seating surface without back support as shown in Figure N4, with the limbs extended horizontally and forward, parallel to the midsagittal plane, the midsagittal plane vertical within ± 1 degree and the ribs level in the anterior-

posterior and lateral directions within ± 0.5 degrees.

(3) Establish the impact point at the chest midsagittal plane so that the impact point of the longitudinal centerline of the probe coincides with the midsagittal plane of the dummy within ± 2.5 mm (0.1 in) and is 12.7 ± 1.1 mm (0.5 ± 0.04 in) below the horizontal-peripheral centerline of the No. 3 rib and is within 0.5 degrees of a horizontal line in the dummy's midsagittal plane.

(4) Impact the thorax with the test probe so that at the moment of contact the probe's longitudinal center line falls within 2 degrees of a horizontal line in the dummy's midsagittal plane.

(5) Guide the test probe during impact so that there is no significant lateral, vertical or rotational movement.

(6) No suspension hardware, suspension cables, or any other attachments to the probe, including the velocity vane, shall make contact with the dummy during the test.

[65 FR 2065, Jan. 13, 2000, as amended at 67 FR 47327, July 18, 2002]

§ 572.125 Upper and lower torso assemblies and torso flexion test procedure.

(a) *Upper/lower torso assembly.* The test objective is to determine the stiffness effects of the lumbar spine (drawing 127–3002), including cable (drawing 127–8095), mounting plate insert (drawing 910420–048), nylon shoulder bushing (drawing 9001373), nut (drawing 9001336), and abdominal insert (drawing 127–8210), on resistance to articulation between upper torso assembly (drawing 127–2000) and lower torso assembly (drawing 127–3000).

(b)(1) When the upper torso assembly of a seated dummy is subjected to a force continuously applied at the head to neck pivot pin level through a rigidly attached adaptor bracket as shown in Figure N5 according to the test procedure set out in paragraph (c) of this section, the lumbar spine-abdomen assembly shall flex by an amount that permits the upper torso assembly to translate in angular motion until the machined rear surface of the instrument cavity at the back of the thoracic spine box is at 45 ± 0.5 degrees relative to the vertical transverse plane, at which time the force applied as shown

in Figure N5 must be not less than 147 N (33 lbf) and not more than 200 N (45 lbf), and

(2) Upon removal of the force, the torso assembly must return to within 8 degrees of its initial position.

(c) *Test procedure.* The test procedure for the torso assemblies is as follows:

(1) Soak the dummy in a controlled environment at any temperature between 18.9 and 25.6 °C (66 and 78 °F) and a relative humidity between 10 and 70 percent for at least four hours prior to a test.

(2) Attach the dummy (with or without the legs below the femurs) to the fixture in a seated posture as shown in Figure N5.

(3) Secure the pelvis at the pelvis instrument cavity rear face by threading four ¼ in cap screws into the available threaded attachment holes. Tighten the mountings so that the test material is rigidly affixed to the test fixture and the pelvic-lumbar joining surface is horizontal.

(4) Flex the thorax forward three times between vertical and until the torso reference plane, as shown in figure N5, reaches 30 ±2 degrees from vertical. Bring the torso to vertical orientation, remove all externally applied flexion forces, and wait 30 minutes before conducting the test. During the 30-minute waiting period, the dummy's upper torso shall be externally supported at or near its vertical orientation to prevent sagging.

(5) Remove the external support and wait two minutes. Measure the initial orientation of the torso reference plane of the seated, unsupported dummy as shown in Figure N5. This initial torso orientation angle may not exceed 22 degrees.

(6) Attach the loading adapter bracket to the spine of the dummy, the pull cable, and the load cell as shown in Figure N5.

(7) Apply a tension force in the midsagittal plane to the pull cable as shown in Figure N5 at any upper torso deflection rate between 0.5 and 1.5 degrees per second, until the torso reference plane is at 45 ±0.5 degrees of flexion relative to the vertical transverse plane as shown in Figure N5.

(8) Continue to apply a force sufficient to maintain 45 ±0.5 degrees of

flexion for 10 seconds, and record the highest applied force during the 10-second period.

(9) Release all force as rapidly as possible, and measure the return angle at 3 minutes or any time thereafter after the release.

§572.126 Knees and knee impact test procedure.

(a) *Knee assembly.* The knee assembly is part of the leg assembly (drawing 127-4000-1 and -2).

(b) When the knee assembly, consisting of knee machined (drawing 127-4013), knee flesh (drawing 127-4011), lower leg (drawing 127-4014), the foot assembly (drawing 127-4030-1(left) and -2 (right)) and femur load transducer (drawing SA572-S10) or its structural replacement (drawing 127-4007) is tested according to the test procedure in section 572.127(c), the peak resistance force as measured with the test probe mounted accelerometer must be not less than 2.0 kN (450 lbf) and not more than 3.0 kN (674 lbf).

(c) *Test procedure.* The test procedure for the knee assembly is as follows:

(1) Soak the knee assembly in a controlled environment at any temperature between 18.9 and 25.6 °C (66 and 78 °F) and a relative humidity from 10 to 70 percent for at least four hours prior to a test.

(2) Mount the test material and secure it to a rigid test fixture as shown in Figure N6. No contact is permitted between any part of the foot or tibia and any exterior surface.

(3) Align the test probe so that throughout its stroke and at contact with the knee it is within 2 degrees of horizontal and collinear with the longitudinal centerline of the femur.

(4) Guide the pendulum so that there is no significant lateral vertical or rotational movement at time-zero.

(5) The test probe velocity at the time of contact shall be 2.1 ±0.03 m/s (6.9 # 0.1 ft/s).

(6) No suspension hardware, suspension cables, or any other attachments to the probe, including the velocity vane, shall make contact with the dummy during testing.

[65 FR 2065, Jan. 13, 2000, as amended at 67 FR 47328, July 18, 2002]

§ 572.127 Test conditions and instrumentation.

(a) The test probe for thoracic impacts, except for attachments, shall be of rigid metal or metal alloy construction and concentric about its longitudinal axis. Any attachments to the impactor, such as suspension hardware, velocity vanes, etc., must meet the requirements of § 572.124(c)(6). The impactor shall have a mass of 2.86 ± 0.02 kg (6.3 ± 0.05 lb) and a minimum mass moment of inertia of 160 kg-c^2 ($0.141 \text{ lb-in-sec}^2$) in yaw and pitch about the CG of the probe. One third of the weight of suspension cables and any attachments to the impact probe must be included in the calculation of mass, and such components may not exceed five percent of the total weight of the probe. The impacting end of the probe, has a flat, continuous, and non-deformable 101.6 ± 0.25 mm (4.00 ± 0.01 in) diameter face with an edge radius of $7.6/12.7$ mm ($0.3/0.5$ in). The impactor shall have a $101\text{--}103$ mm ($4.0\text{--}4.1$ in) diameter cylindrical surface extending for a minimum of 12.5 mm (0.5 in) to the rear from the impact face. The probe's end opposite to the impact face has provisions for mounting an accelerometer with its sensitive axis collinear with the longitudinal axis of the probe. The impact probe shall have a free air resonant frequency of not less than 1000 Hz limited to the direction of the longitudinal axis of the impactor.

(b) The test probe for knee impacts, except for attachments, shall be of rigid metal or alloy construction and concentric about its longitudinal axis. Any attachments to the impactor, such as suspension hardware, velocity vanes, etc., must meet the requirements of § 572.126(c)(6). The impactor shall have a mass of 0.82 ± 0.02 kg (1.8 ± 0.05 lb) and a minimum mass moment of inertia of 34 kg-cm^2 (0.03 lb-in-sec^2) in yaw and pitch about the CG of the probe. One third of the weight of suspension cables and any attachments to the impact probe must be included in the calculation of mass, and such components may not exceed five percent of the total weight of the probe. The impacting end of the probe, has a flat, continuous, and non-deformable 76.2 ± 0.2 mm (3.00 ± 0.01 in) diameter face with an edge radius of $7.6/12.7$ mm ($0.3/0.5$ in).

The impactor shall have a $76\text{--}77$ mm ($3.0\text{--}3.1$ in) diameter cylindrical surface extending for a minimum of 12.5 mm (0.5 in) to the rear from the impact face. The probe's end opposite to the impact face has provisions for mounting an accelerometer with its sensitive axis collinear with the longitudinal axis of the probe. The impact probe shall have a free air resonant frequency of not less than 1000 Hz limited to the direction of the longitudinal axis of the impactor.

(c) Head accelerometers shall have dimensions, response characteristics, and sensitive mass locations specified in drawing SA572-S4 and be mounted in the head as shown in drawing 127-0000 sheet 3.

(d) *Neck force/moment transducer.* (1) The upper neck force/moment transducer shall have the dimensions, response characteristics, and sensitive axis locations specified in drawing SA572-S11 and be mounted in the head-neck assembly as shown in drawing 127-0000 sheet 3.

(2) The optional lower neck force/moment transducer shall have the dimensions, response characteristics, and sensitive axis locations specified in drawing SA572-S26 and be mounted as shown in drawing 127-0000 sheet 3.

(e) The thorax accelerometers shall have the dimensions, response characteristics, and sensitive mass locations specified in drawing SA572-S4 and be mounted in the torso assembly in triaxial configuration at T4, and as optional instrumentation in uniaxial forward-aft oriented configuration on the most anterior ends of ribs #1 and #6 and at the spine box at the levels of #1 and #6 ribs as shown in 127-0000 sheet 3.

(f) The chest deflection transducer shall have the dimensions and response characteristics specified in drawing SA572-S50 and be mounted in the upper torso assembly as shown in 127-0000 sheet 3.

(g) The optional lumbar spine force-moment transducer shall have the dimensions, response characteristics, and sensitive axis locations specified in drawing SA572-S12 and be mounted in the lower torso assembly as shown in drawing 127-0000 sheet 3 as a replacement for lumbar adaptor 127-3005.

(h) The optional iliac spine force transducers shall have the dimensions and response characteristics specified in drawing SA572-S13 and be mounted in the torso assembly as shown in drawing 127-0000 sheet 3 as a replacement for ASIS load cell 127-3015-1 (left) and -2 (right).

(i) The optional pelvis accelerometers shall have the dimensions, response characteristics, and sensitive mass locations specified in drawing SA572-S4 and be mounted in the torso assembly in triaxial configuration in the pelvis bone as shown in drawing 127-0000 sheet 3.

(j) The femur force transducer shall have the dimensions and response characteristics specified in drawing SA72-S10 and be mounted in the leg assembly as shown in drawing 127-0000 sheet 3.

(k) The outputs of acceleration and force-sensing devices installed in the dummy and in the test apparatus specified by this part must be recorded in individual data channels that conform to SAE Recommended Practice J211, Rev. Mar95 "Instrumentation for Impact Tests," except that the lumbar measurements are based on CFC 600, with channel classes as follows:

- (1) Head acceleration—Class 1000.
- (2) Neck:
 - (i) Forces—Class 1000;
 - (ii) Moments—Class 600;
 - (iii) Pendulum acceleration—Class 180;
 - (iv) Rotation—Class 60 (if used).

- (3) Thorax:
 - (i) Rib acceleration—Class 1000;
 - (ii) Spine and pendulum accelerations—Class 180;
 - (iii) Sternum deflection—Class 600.
- (4) Lumbar:
 - (i) Forces—Class 1000;
 - (ii) Moments—Class 600;
 - (iii) Flexion—Class 60 if data channel is used.

- (5) Pelvis accelerations—Class 1000.
- (6) Femur forces—Class 600.
- (l) Coordinate signs for instrumentation polarity shall conform to the Sign Convention For Vehicle Crash Testing, Surface Vehicle Information Report, SAE J1733, 1994-12.

(m) The mountings for sensing devices shall have no resonance frequency less than 3 times the frequency range of the applicable channel class.

(n) Limb joints must be set at one G, barely restraining the weight of the limb when it is extended horizontally. The force needed to move a limb segment shall not exceed 2G throughout the range of limb motion.

(o) Performance tests of the same component, segment, assembly, or fully assembled dummy shall be separated in time by period of not less than 30 minutes unless otherwise noted.

(p) Surfaces of dummy components may not be painted except as specified in this subpart or in drawings subtended by this subpart.

[65 FR 2065, Jan. 13, 2000, as amended at 67 FR 47328, July 18, 2002]

FIGURES TO SUBPART N OF PART 572

Figure N 1
HEAD DROP TEST SET-UP SPECIFICATIONS

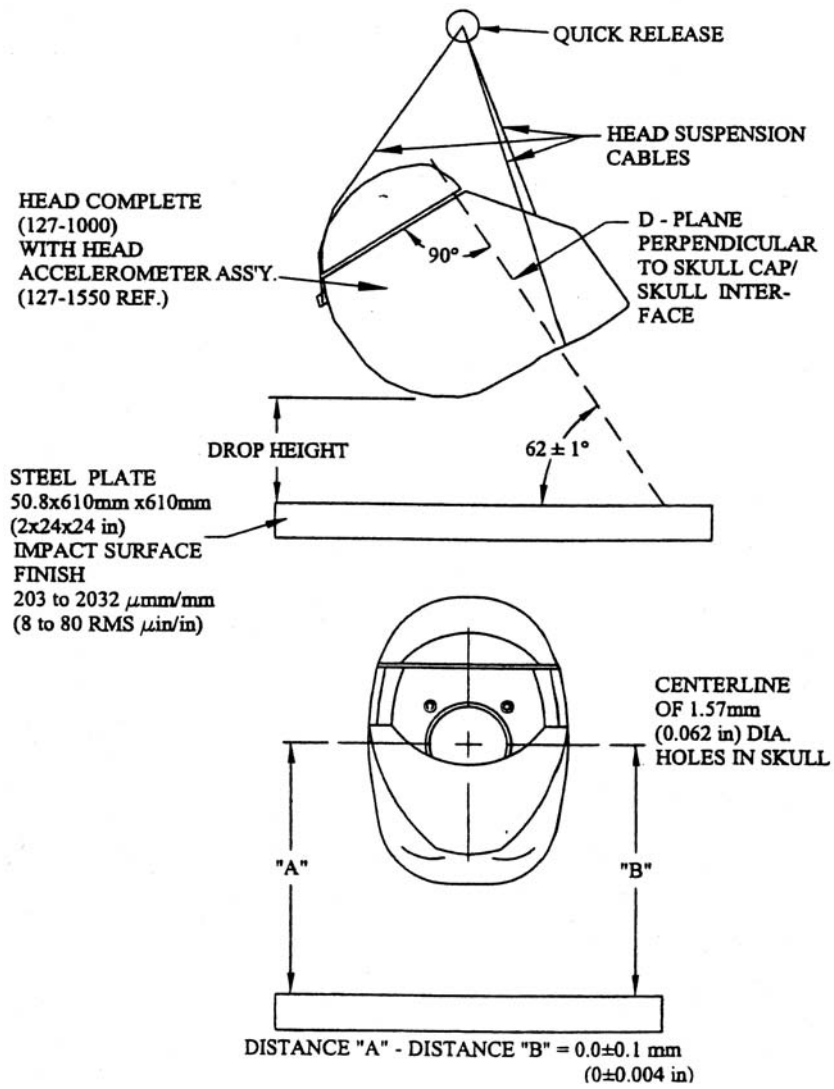
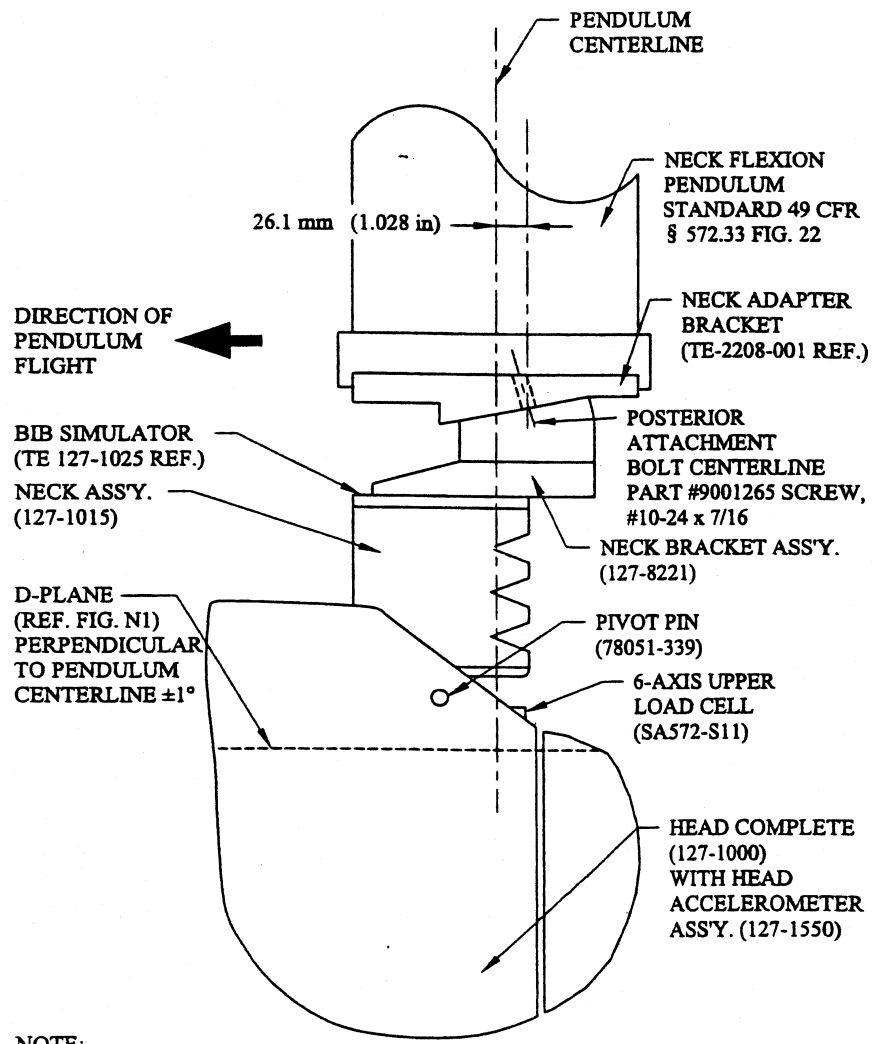


Figure N 2

NECK FLEXION TEST SET-UP SPECIFICATIONS



NOTE:
PENDULUM SHOWN IN VERTICAL ORIENTATION

Figure N3

NECK EXTENSION TEST SET-UP SPECIFICATIONS

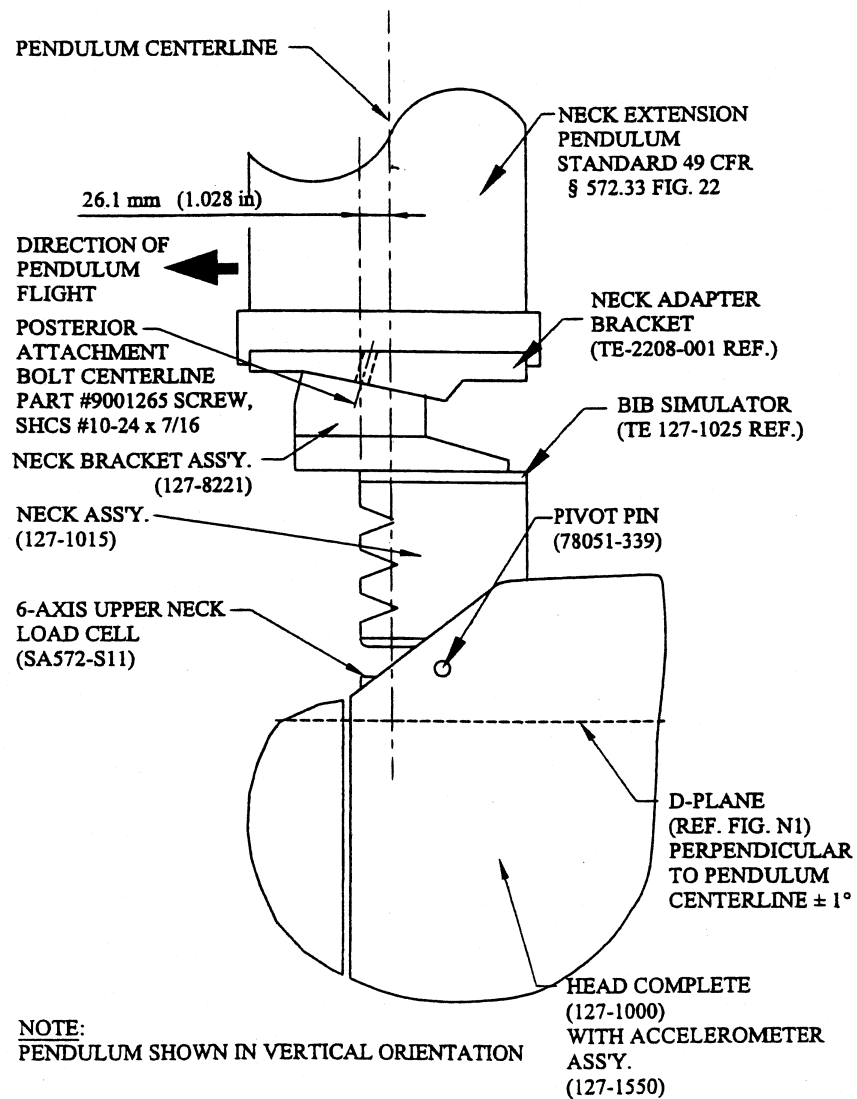
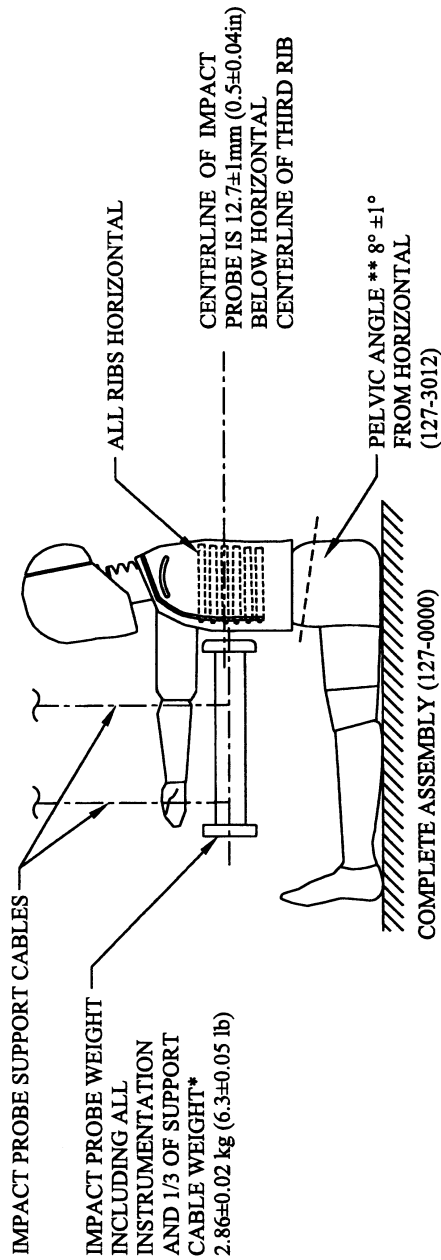


FIGURE N 4
THORAX IMPACT TEST SET-UP SPECIFICATIONS



* 1/3 CABLE WEIGHT NOT TO EXCEED 5% OF THE TOTAL IMPACT PROBE WEIGHT

** PELVIS LUMBAR JOINING SURFACE

FIGURE N 5
TORSO FLEXION TEST SET-UP SPECIFICATIONS

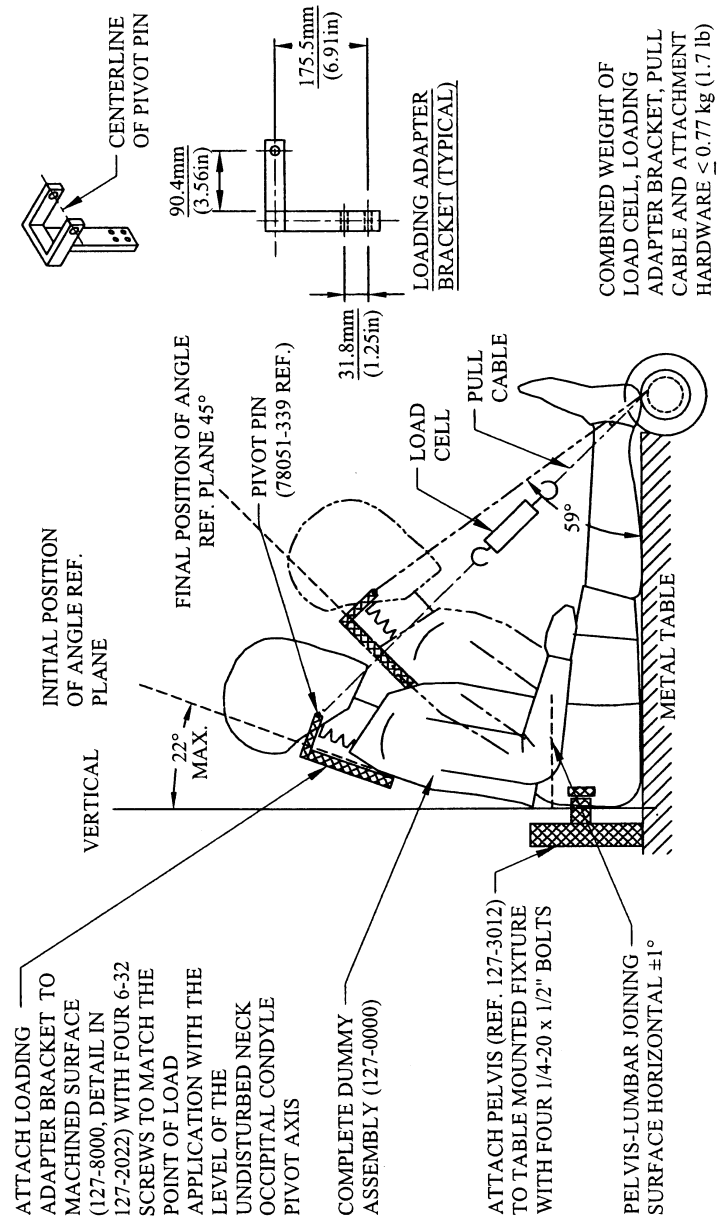
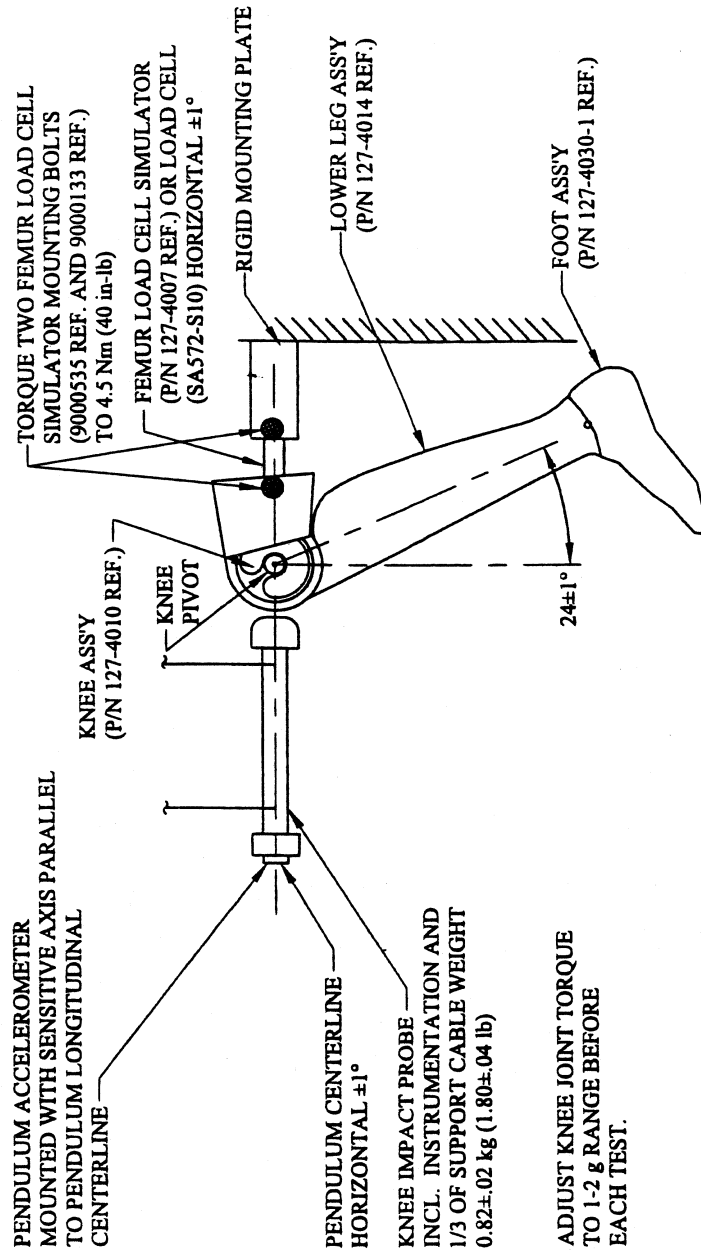


FIGURE N 6
KNEE IMPACT TEST SET-UP SPECIFICATIONS



[65 FR 2065, Jan. 13, 2000, as amended at 67 FR 47329, July 18, 2002; 67 FR 59023, Sept. 19, 2002]

Subpart O—Hybrid III 5th Percentile Female Test Dummy, Alpha Version

SOURCE: 65 FR 10968, Mar. 1, 2000, unless otherwise noted.

§ 572.130 Incorporation by reference.

(a) The following materials are hereby incorporated into this Subpart by reference:

(1) A drawings and specification package entitled “Parts List and Drawings, Part 572 Subpart O Hybrid III Fifth Percentile Small Adult Female Crash Test Dummy (HIII–5F, Alpha Version)” (June 2002), incorporated by reference in “572.131, and consisting of:

(i) Drawing No. 880105–100X, Head Assembly, incorporated by reference in §§ 572.131, 572.132, 572.133, 572.134, 572.135, and 572.137;

(ii) Drawing No. 880105–250, Neck Assembly, incorporated by reference in §§ 572.131, 572.133, 572.134, 572.135, and 572.137;

(iii) Drawing No. 880105–300, Upper Torso Assembly, incorporated by reference in §§ 572.131, 572.134, 572.135, and 572.137;

(iv) Drawing No. 880105–450, Lower Torso Assembly, incorporated by reference in §§ 572.131, 572.134, 572.135, and 572.137;

(v) Drawing No. 880105–560–1, Complete Leg Assembly—left, incorporated by reference in §§ 572.131, 572.135, 572.136, and 572.137;

(vi) Drawing No. 880105–560–2, Complete Leg Assembly—right incorporated by reference in §§ 572.131, 572.135, 572.136, and 572.137;

(vii) Drawing No. 880105–728–1, Complete Arm Assembly—left, incorporated by reference in §§ 572.131, 572.134, and 572.135 as part of the complete dummy assembly;

(viii) Drawing No. 880105–728–2, Complete Arm Assembly—right, incorporated by reference in §§ 572.131, 572.134, and 572.135 as part of the complete dummy assembly;

(ix) The Hybrid III 5th percentile small adult female crash test dummy parts list, incorporated by reference in § 572.131;

(2) A procedures manual entitled “Procedures for Assembly, Disassembly, and Inspection (PADI) Sub-

part O Hybrid III Fifth Percentile Adult Female Crash Test Dummy (HIII–5F), Alpha Version” (February 2002), incorporated by reference in § 572.132.

(3) SAE Recommended Practice J211/1, Rev. Mar 95 “Instrumentation for Impact Tests—Part 1—Electronic Instrumentation”, incorporated by reference in § 572.137;

(4) SAE Recommended Practice J211/2, Rev. Mar 95 “Instrumentation for Impact Tests—Part 2—Photographic Instrumentation” incorporated by reference in § 572.137; and

(5) SAE J1733 of 1994–12 “Sign Convention for Vehicle Crash Testing”, incorporated by reference in § 572.137.

(b) The Director of the Federal Register approved the materials incorporated by reference in accordance with 5 U.S.C. 552(a) and 1 CFR part 51. Copies of the materials may be inspected at NHTSA’s Technical Reference Library, 400 Seventh Street SW., room 5109, Washington, DC, or at the National Archives and Records Administration (NARA). For information on the availability of this material at NARA, call 202–741–6030, or go to: http://www.archives.gov/federal_register/code_of_federal_regulations/ibr_locations.html.

(c) The incorporated materials are available as follows:

(1) The Parts List and Drawings, Part 572 Subpart O Hybrid III Fifth Percentile Small Adult Female Crash Test Dummy, (HIII–5F, Alpha Version) (June 2002), referred to in paragraph (a)(1) of this section and the Procedures for Assembly, Disassembly, and Inspection (PADI) of the Hybrid III 5th Percentile Small Adult Female Crash Test Dummy, Alpha Version, referred to in paragraph (a)(2) of this section are available from Reprographic Technologies, 9107 Gaither Road, Gaithersburg, MD 20877, (301) 419–5070. These documents are also accessible for reading and copying through the DOT Docket Management System.

(2) The SAE materials referred to in paragraphs (a)(3) and (a)(4) of this section are available from the Society of

Automotive Engineers, Inc., 400 Commonwealth Drive, Warrendale, Pa. 15096.

[65 FR 10968, Mar. 1, 2000, as amended at 67 FR 46413, July 15, 2002]

§ 572.131 General description.

(a) The Hybrid III fifth percentile adult female crash test dummy is defined by drawings and specifications containing the following materials:

(1) Technical drawings and specifications package P/N 880105-000 (refer to § 572.130(a)(1)), the titles of which are listed in Table A;

(2) Parts List and Drawings, Part 572 Subpart O Hybrid III Fifth Percentile Small Adult Female Crash Test Dummy (HIII-5F, Alpha Version) (June 2002) (refer to § 572.130(a)(1)(ix)).

TABLE A

Component assembly	Drawing No.
Head Assembly	880105-100X
Neck Assembly	880105-250
Upper Torso Assembly	880105-300
Lower Torso Assembly	880105-450
Complete Leg Assembly—left	880105-560-1
Complete Leg Assembly—right	880105-560-2
Complete Arm Assembly—left	880105-728-1
Complete Arm Assembly—right	880105-728-2

(b) Adjacent segments are joined in a manner such that, except for contacts existing under static conditions, there is no contact between metallic elements throughout the range of motion or under simulated crash impact conditions.

(c) The structural properties of the dummy are such that the dummy conforms to this Subpart in every respect before use in any test similar to those specified in Standard 208, Occupant Crash Protection.

[65 FR 10968, Mar. 1, 2000, as amended at 67 FR 46414, July 15, 2002]

§ 572.132 Head assembly and test procedure.

(a) The head assembly (refer to § 572.130(a)(1)(i)) for this test consists of the complete head (drawing 880105-100X), a six-axis neck transducer (drawing SA572-S11) or its structural replacement (drawing 78051-383X), and 3 accelerometers (drawing SA572-S4).

(b) When the head assembly is dropped from a height of 376.0 ±1.0 mm

(14.8 ±0.04 in) in accordance with subsection (c) of this section, the peak resultant acceleration at the location of the accelerometers at the head CG may not be less than 250 G or more than 300 G. The resultant acceleration vs. time history curve shall be unimodal; oscillations occurring after the main pulse must be less than 10 percent of the peak resultant acceleration. The lateral acceleration shall not exceed 15 G (zero to peak).

(c) *Head test procedure.* The test procedure for the head is as follows:

(1) Soak the head assembly in a controlled environment at any temperature between 18.9 and 25.6 °C (66 and 78 °F) and a relative humidity from 10 to 70 percent for at least four hours prior to a test.

(2) Prior to the test, clean the impact surface of the skin and the impact plate surface with isopropyl alcohol, trichloroethane, or an equivalent. The skin of the head must be clean and dry for testing.

(3) Suspend and orient the head assembly as shown in Figure 19 of 49 CFR 572. The lowest point on the forehead must be 376.0 ±1.0 mm (14.8 ±0.04 in) from the impact surface. The 1.57 mm (0.062 in) diameter holes located on either side of the dummy's head shall be used to ensure that the head is level with respect to the impact surface.

(4) Drop the head assembly from the specified height by means that ensure a smooth, instant release onto a rigidly supported flat horizontal steel plate which is 50.8 mm (2.0 in) thick and 610 mm (24.0 in) square. The impact surface shall be clean, dry and have a micro finish of not less than 203.2×10⁻⁶ mm (8 micro inches) (RMS) and not more than 2032.0×10⁻⁶ mm (80 micro inches) (RMS).

(5) Allow at least 2 hours between successive tests on the same head.

§ 572.133 Neck assembly and test procedure.

(a) The neck assembly (refer to § 572.130(a)(1)(ii)) for the purposes of this test consists of the assembly of components shown in drawing 880105-250.

(b) When the head-neck assembly consisting of the head (drawing 880105-100X), neck (drawing 880105-250), bib

simulator (drawing 880105–371), upper neck adjusting bracket (drawing 880105–207), lower neck adjusting bracket (drawing 880105–208), six-axis neck transducer (drawing SA572–S11), and either three accelerometers (drawing SA572–S4) or their mass equivalent installed in the head assembly as specified in drawing 880105–100X, is tested according to the test procedure in subsection (c) of this section, it shall have the following characteristics:

(1) *Flexion.* (i) Plane D, referenced in Figure O1, shall rotate in the direction of preimpact flight with respect to the pendulum’s longitudinal centerline between 77 degrees and 91 degrees. During the time interval while the rotation is within the specified corridor, the peak moment, measured by the neck transducer (drawing SA5572–311), about the occipital condyles may not be less than 69 N-m (51 ft-lbf) and not more than 83 N-m (61 ft-lbf). The positive moment shall decay for the first time to 10 N-m (7.4 ft-lbf) between 80 ms and 100 ms after time zero.

(ii) The moment shall be calculated by the following formula: Moment (N-m) = $M_y - (0.01778m) \times (F_x)$.

(iii) M_y is the moment about the y-axis, F_x is the shear force measured by the neck transducer (drawing SA572–S11), and 0.01778m is the distance from force to occipital condyle.

(2) *Extension.* (i) Plane D, referenced in Figure O2, shall rotate in the direction of preimpact flight with respect to the pendulum’s longitudinal centerline between 99 degrees and 114 degrees. During the time interval while the rotation is within the specified corridor, the peak moment, measured by the neck transducer (drawing SA5572–S11), about the occipital condyles shall be not more than –53 N-m (–39 ft-lbf) and not less than –65 N-m (–48 ft-lbf). The negative moment shall decay for the first time to –10 N-m (–7.4 ft-lbf) between 94 ms and 114 ms after time zero.

(ii) The moment shall be calculated by the following formula: Moment (N-m) = $M_y - (0.01778m) \times (F_x)$.

(iii) M_y is the moment about the y-axis, F_x is the shear force measured by the neck transducer (drawing SA572–S11), and 0.01778 m is the distance from force to occipital condyle.

(3) Time-zero is defined as the time of initial contact between the pendulum striker plate and the honeycomb material. All data channels shall be at the zero level at this time.

(c) *Test Procedure.* The test procedure for the neck assembly is as follows:

(1) Soak the neck assembly in a controlled environment at any temperature between 20.6 and 22.2 °C (69 and 72 °F) and a relative humidity between 10 and 70 percent for at least four hours prior to a test.

(2) Torque the jam nut (drawing 9000018) on the neck cable (drawing 880105–206) to 1.4 ±0.2 N-m (12.0 ±2.0 in-lb).

(3) Mount the head-neck assembly, defined in subsection (b) of this section, on the pendulum described in Figure 22 of 49 CFR 572 so that the midsagittal plane of the head is vertical and coincides with the plane of motion of the pendulum as shown in Figure O1 for flexion tests and Figure O2 for extension tests.

(4)(i) Release the pendulum and allow it to fall freely from a height to achieve an impact velocity of 7.01 ±0.12 m/s (23.0 ±0.4 ft/s) for flexion tests and 6.07 ±0.12 m/s (19.9 ±0.40 ft/s) for extension tests, measured by an accelerometer mounted on the pendulum as shown in Figure 22 of 49 CFR 572 at the instant of contact with the honeycomb.

(ii) Stop the pendulum from the initial velocity with an acceleration vs. time pulse which meets the velocity change as specified below. Integrate the pendulum acceleration data channel to obtain the velocity vs. time curve:

TABLE B—PENDULUM PULSE

Time ms	Flexion		Extension	
	m/s	ft/s	m/s	ft/s
10	2.1–2.5	6.9–8.2	1.5–1.9	4.9–6.2
20	4.0–5.0	13.1–16.4	3.1–3.9	10.2–12.8
30	5.8–7.0	19.5–23.0	4.6–5.6	15.1–18.4

[65 FR 10968, Mar. 1, 2000, as amended at 67 FR 46414, July 15, 2002]

§ 572.134 Thorax assembly and test procedure.

(a) Thorax (Upper Torso) Assembly (refer to § 572.130(a)(1)(iii)). The thorax consists of the part of the torso assembly shown in drawing 880105-300.

(b) When the anterior surface of the thorax of a completely assembled dummy (drawing 880105-000) is impacted by a test probe conforming to section 572.137(a) at 6.71 ± 0.12 m/s (22.0 ± 0.4 ft/s) according to the test procedure in subsection (c) of this section:

(1) Maximum sternum displacement (compression) relative to the spine, measured with chest deflection transducer (drawing SA572-S5), must be not less than 50.0 mm (1.97 in) and not more than 58.0 mm (2.30 in). Within this specified compression corridor, the peak force, measured by the impact probe as defined in section 572.137 and calculated in accordance with paragraph (b)(3) of this section, shall not be less than 3900 N (876 lbf) and not more than 4400 N (989 lbf). The peak force after 18.0 mm (0.71 in) of sternum displacement but before reaching the minimum required 50.0 mm (1.97 in) sternum displacement limit shall not exceed 4600 N.

(2) The internal hysteresis of the ribcage in each impact as determined by the plot of force vs. deflection in paragraph (1) of this section shall be not less than 69 percent but not more than 85 percent. The hysteresis shall be calculated by determining the ratio of the area between the loading and unloading portions of the force deflection curve to the area under the loading portion of the curve.

(3) The force shall be calculated by the product of the impactor mass and its deceleration.

(c) *Test procedure.* The test procedure for the thorax assembly is as follows:

(1) The dummy is clothed in a form fitting cotton stretch above-the-elbow sleeved shirt and above-the-knee pants. The weight of the shirt and pants shall not exceed 0.14 kg (0.30 lb) each.

(2) Soak the dummy in a controlled environment at any temperature between 20.6 and 22.2 °C (69 and 72 °F) and a relative humidity between 10 and 70

percent for at least four hours prior to a test.

(3) Seat and orient the dummy on a seating surface without back support as shown in Figure O3, with the limbs extended horizontally and forward, parallel to the midsagittal plane, the midsagittal plane vertical within ± 1 degree and the ribs level in the anterior-posterior and lateral directions within ± 0.5 degrees.

(4) Establish the impact point at the chest midsagittal plane so that the impact point of the longitudinal centerline of the probe coincides with the midsagittal plane of the dummy within ± 2.5 mm (0.1 in) and is 12.7 ± 1.1 mm (0.5 ± 0.04 in) below the horizontal-peripheral centerline of the No. 3 rib and is within 0.5 degrees of a horizontal line in the dummy's midsagittal plane.

(5) Impact the thorax with the test probe so that at the moment of contact the probe's longitudinal center line falls within 2 degrees of a horizontal line in the dummy's midsagittal plane.

(6) Guide the test probe during impact so that there is no significant lateral, vertical or rotational movement.

(7) No suspension hardware, suspension cables, or any other attachments to the probe, including the velocity vane, shall make contact with the dummy during the test.

[65 FR 10968, Mar. 1, 2000, as amended at 67 FR 46415, July 15, 2002]

§ 572.135 Upper and lower torso assemblies and torso flexion test procedure.

(a) *Upper/lower torso assembly.* The test objective is to determine the stiffness effects of the lumbar spine (drawing 880105-1096), and abdominal insert (drawing 880105-434), on resistance to articulation between the upper torso assembly (drawing 880105-300) and the lower torso assembly (drawing 880105-450) (refer to § 572.130(a)(1)(iv)).

(b)(1) When the upper torso assembly of a seated dummy is subjected to a force continuously applied at the head to neck pivot pin level through a rigidly attached adaptor bracket as shown in Figure O4 according to the test procedure set out in subsection (c) of this section, the lumbar spine-abdomen assembly shall flex by an amount that permits the upper torso assembly to

§572.136

49 CFR Ch. V (10–1–10 Edition)

translate in angular motion relative to the vertical transverse plane 45 ± 0.5 degrees at which time the force applied must be not less than 320 N (71.5 lbf) and not more than 390 N (87.4 lbf), and

(2) Upon removal of the force, the torso assembly must return to within 8 degrees of its initial position.

(c) *Test procedure.* The test procedure for the upper/lower torso assembly is as follows:

(1) Soak the dummy in a controlled environment at any temperature between 18.9 and 25.6 °C (66 and 78 °F) and a relative humidity between 10 and 70 percent for at least four hours prior to a test.

(2) Assemble the complete dummy (with or without the legs below the femurs) and attach to the fixture in a seated posture as shown in Figure O4.

(3) Secure the pelvis to the fixture at the pelvis instrument cavity rear face by threading four ¼ inch cap screws into the available threaded attachment holes. Tighten the mountings so that the test material is rigidly affixed to the test fixture and the pelvic-lumbar joining surface is horizontal.

(4) Attach the loading adapter bracket to the spine of the dummy as shown in Figure O4.

(5) Inspect and adjust, if necessary, the seating of the abdominal insert within the pelvis cavity and with respect to the torso flesh, assuring that the torso flesh provides uniform fit and overlap with respect to the outside surface of the pelvis flesh.

(6) Flex the dummy's upper torso three times between the vertical and until the torso reference plane, as shown in Figure O4, reaches 30 degrees from the vertical transverse plane. Bring the torso to vertical orientation and wait for 30 minutes before conducting the test. During the 30 minute waiting period, the dummy's upper torso shall be externally supported at or near its vertical orientation to prevent it from drooping.

(7) Remove all external support and wait two minutes. Measure the initial orientation angle of the torso reference plane of the seated, unsupported dummy as shown in Figure O4. The initial orientation angle may not exceed 20 degrees.

(8) Attach the pull cable and the load cell as shown in Figure O4.

(9) Apply a tension force in the midsagittal plane to the pull cable as shown in Figure O4 at any upper torso deflection rate between 0.5 and 1.5 degrees per second, until the angle reference plane is at 45 ± 0.5 degrees of flexion relative to the vertical transverse plane.

(9) Continue to apply a force sufficient to maintain 45 ± 0.5 degrees of flexion for 10 seconds, and record the highest applied force during the 10-second period.

(10) Release all force at the attachment bracket as rapidly as possible, and measure the return angle with respect to the initial angle reference plane as defined in paragraph (6) 3 minutes after the release.

§572.136 Knees and knee impact test procedure.

(a) *Knee assembly.* The knee assembly (refer to §§572.130(a)(1)(v) and (vi)) for the purpose of this test is the part of the leg assembly shown in drawing 880105-560.

(b)(1) When the knee assembly, consisting of sliding knee assembly (drawing 880105-528R or -528L), lower leg structural replacement (drawing 880105-603), lower leg flesh (drawing 880105-601), ankle assembly (drawing 880105-660), foot assembly (drawing 880105-651 or 650), and femur load transducer (drawing SA572-S14) or its structural replacement (drawing 78051-319) is tested according to the test procedure in subsection (c), the peak resistance force as measured with the test probe-mounted accelerometer must be not less than 3450 N (776 lbf) and not more than 4060 N (913 lbf).

(2) The force shall be calculated by the product of the impactor mass and its deceleration.

(c) *Test procedure.* The test procedure for the knee assembly is as follows:

(1) Soak the knee assembly in a controlled environment at any temperature between 18.9 and 25.6 °C (66 and 78 °F) and a relative humidity from 10 to 70 percent for at least four hours prior to a test.

(2) Mount the test material and secure it to a rigid test fixture as shown

in Figure O5. No part of the foot or tibia may contact any exterior surface.

(3) Align the test probe so that throughout its stroke and at contact with the knee it is within 2 degrees of horizontal and collinear with the longitudinal centerline of the femur.

(4) Guide the pendulum so that there is no significant lateral vertical or rotational movement at the time of initial contact between the impactor and the knee.

(5) The test probe velocity at the time of contact shall be 2.1 ± 0.03 m/s (6.9 ± 0.1 ft/s).

(6) No suspension hardware, suspension cables, or any other attachments to the probe, including the velocity vane, shall make contact with the dummy during the test.

[65 FR 10968, Mar. 1, 2000, as amended at 67 FR 46415, July 15, 2002]

§572.137 Test conditions and instrumentation.

(a) The test probe for thoracic impacts, except for attachments, shall be of rigid metallic construction and concentric about its longitudinal axis. Any attachments to the impactor, such as suspension hardware, impact vanes, etc., must meet the requirements of §572.134(c)(7). The impactor shall have a mass of 13.97 ± 0.23 kg (30.8 ± 0.5 lbs) and a minimum mass moment of inertia of 3646 kg-cm² (3.22 lbs-in-sec²) in yaw and pitch about the CG of the probe. One-third (1/3) of the weight of suspension cables and any attachments to the impact probe must be included in the calculation of mass, and such components may not exceed five percent of the total weight of the test probe. The impacting end of the probe, perpendicular to and concentric with the longitudinal axis of the probe, has a flat, continuous, and non-deformable 152.4 ± 0.25 mm (6.00 ± 0.01 in) diameter face with a minimum/maximum edge radius of $7.6/12.7$ mm ($0.3/0.5$ in). The impactor shall have a 152.4 – 152.6 mm (6.0 – 6.1 in) diameter cylindrical surface extending for a minimum of 25 mm (1.0 in) to the rear from the impact face. The probe's end opposite to the impact face has provisions for mounting of an accelerometer with its sensitive axis collinear with the longitudinal axis of the probe. The impact probe has a free

air resonant frequency of not less than 1000 Hz, which may be determined using the procedure listed in Docket No. NHTSA-6714-14.

(b) The test probe for knee impacts, except for attachments, shall be of rigid metallic construction and concentric about its longitudinal axis. Any attachments to the impactor, such as suspension hardware, impact vanes, etc., must meet the requirements of §572.136(c)(6). The impactor shall have a mass of 2.99 ± 0.23 kg (6.6 ± 0.5 lbs) and a minimum mass moment of inertia of 209 kg-cm² (0.177 lb-in-sec²) in yaw and pitch about the CG of the probe. One-third (1/3) of the weight of suspension cables and any attachments to the impact probe may be included in the calculation of mass, and such components may not exceed five percent of the total weight of the test probe. The impacting end of the probe, perpendicular to and concentric with the longitudinal axis of the probe, has a flat, continuous, and non-deformable 76.2 ± 0.2 mm (3.00 ± 0.01 in) diameter face with a minimum/maximum edge radius of $7.6/12.7$ mm ($0.3/0.5$ in). The impactor shall have a 76.2 – 76.4 mm (3.0 – 3.1 in) diameter cylindrical surface extending for a minimum of 12.5 mm (0.5 in) to the rear from the impact face. The probe's end opposite to the impact face has provisions for mounting an accelerometer with its sensitive axis collinear with the longitudinal axis of the probe. The impact probe has a free air resonant frequency of not less than 1000 Hz, which may be determined using the procedure listed in Docket No. NHTSA-6714-14.

(c) Head accelerometers shall have dimensions, response characteristics, and sensitive mass locations specified in drawing SA572-S4 and be mounted in the head as shown in drawing 880105-000 sheet 3 of 6.

(d) The upper neck force/moment transducer shall have the dimensions, response characteristics, and sensitive axis locations specified in drawing SA572-S11 and be mounted in the head neck assembly as shown in drawing 880105-000, sheet 3 of 6.

(e) The thorax accelerometers shall have the dimensions, response characteristics, and sensitive mass locations specified in drawing SA572-S4 and be

§572.137

49 CFR Ch. V (10–1–10 Edition)

mounted in the torso assembly in triaxial configuration within the spine box instrumentation cavity and as optional instrumentation in uniaxial forward-aft oriented configuration arranged as corresponding pairs in three locations on the sternum on and at the spine box of the upper torso assembly as shown in drawing 880105-000 sheet 3 of 6.

(f) The optional lumbar spine force/moment transducer shall have the dimensions, response characteristics, and sensitive axis locations specified in drawing SA572-S15 and be mounted in the lower torso assembly as shown in drawing 880105-450.

(g) The optional iliac spine force transducers shall have the dimensions and response characteristics specified in drawing SA572-S16 and be mounted in the torso assembly as shown in drawing 880105-450.

(h) The pelvis accelerometers shall have the dimensions, response characteristics, and sensitive mass locations specified in drawing SA572-S4 and be mounted in the torso assembly in triaxial configuration in the pelvis bone as shown in drawing 880105-000 sheet 3.

(i) The single axis femur force transducer (SA572-S14) or the optional multiple axis femur force/moment transducer (SA572-S29) shall have the dimensions, response characteristics, and sensitive axis locations specified in the appropriate drawing and be mounted in the femur assembly as shown in drawing 880105-500 sheet 3 of 6.

(j) The chest deflection transducer shall have the dimensions and response characteristics specified in drawing SA572-S51 and be mounted to the upper torso assembly as shown in drawings 880105-300 and 880105-000 sheet 3 of 6.

(k) The optional lower neck force/moment transducer shall have the dimensions, response characteristics, and sensitive axis locations specified in drawing SA572-S27 and be mounted to the upper torso assembly as shown in drawing 880105-000 sheet 3 of 6.

(l) The optional thoracic spine force/moment transducer shall have the dimensions, response characteristics, and sensitive axis locations specified in drawing SA572-S28 and be mounted in the upper torso assembly as shown in drawing 880105-000 sheet 3 of 6.

(m) The outputs of acceleration and force-sensing devices installed in the dummy and in the test apparatus specified by this part shall be recorded in individual data channels that conform to SAE Recommended Practice J211/10, Rev. Mar95 “Instrumentation for Impact Tests;—Part 1—Electronic Instrumentation,” and SAE Recommended Practice J211/2, Rev. Mar95 “Instrumentation for Impact Tests—Part 2—Photographic Instrumentation”, (refer to §§572.130(a)(3) and (4) respectively) except as noted, with channel classes as follows:

- (1) Head acceleration—Class 1000
- (2) Neck:
 - (i) Forces—Class 1000
 - (ii) Moments—Class 600
 - (iii) Pendulum acceleration—Class 180
 - (iv) Rotation potentiometer—Class 60 (optional)
- (3) Thorax:
 - (i) Rib acceleration—Class 1000
 - (ii) Spine and pendulum accelerations—Class 180
 - (iii) Sternum deflection—Class 600
 - (iv) Forces—Class 1000
 - (v) Moments—Class 600
- (4) Lumbar:
 - (i) Forces—Class 1000
 - (ii) Moments—Class 600
 - (iii) Torso flexion pulling force—Class 60 if data channel is used
- (5) Pelvis:
 - (i) Accelerations—Class 1000
 - (ii) Iliac wing forces—Class 180
- (6) Femur forces and knee pendulum—Class 600
- (n) Coordinate signs for instrumentation polarity shall conform to the Sign Convention For Vehicle Crash Testing, Surface Vehicle Information Report, SAE J1733, 1994-12 (refer to section 572.130(a)(4)).
- (o) The mountings for sensing devices shall have no resonance frequency less than 3 times the frequency range of the applicable channel class.
- (p) Limb joints must be set at one G, barely restraining the weight of the limb when it is extended horizontally. The force needed to move a limb segment shall not exceed 2G throughout the range of limb motion.
- (q) Performance tests of the same component, segment, assembly, or

Nat'l Highway Traffic Safety Admin., DOT

§ 572.137

fully assembled dummy shall be separated in time by not less than 30 minutes unless otherwise noted.

(r) Surfaces of dummy components may not be painted except as specified

in this subpart or in drawings subtended by this subpart.

[65 FR 10968, Mar. 1, 2000, as amended at 67 FR 46415, July 15, 2002; 74 FR 29894, June 23, 2009]

FIGURES TO SUBPART O OF PART 572

FIGURE 01
NECK FLEXION TEST SETUP SPECIFICATIONS

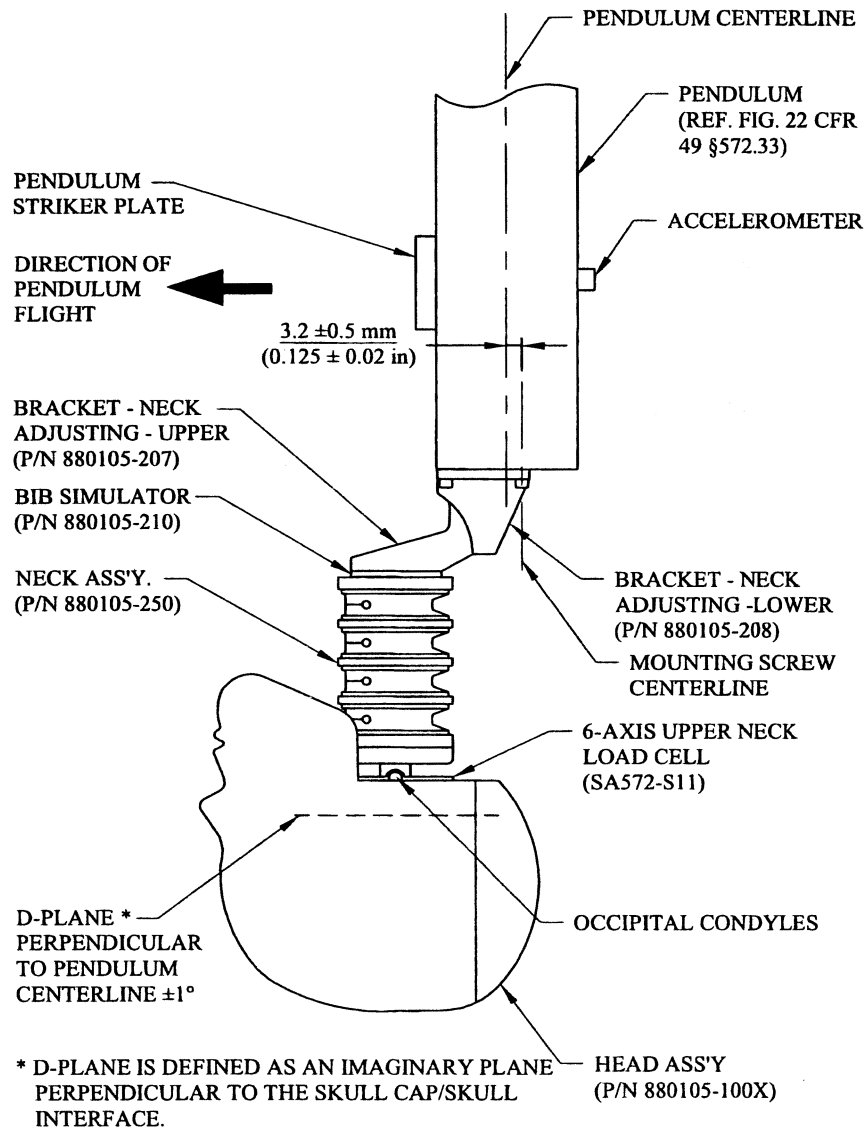


FIGURE O2
NECK EXTENSION TEST SETUP SPECIFICATIONS

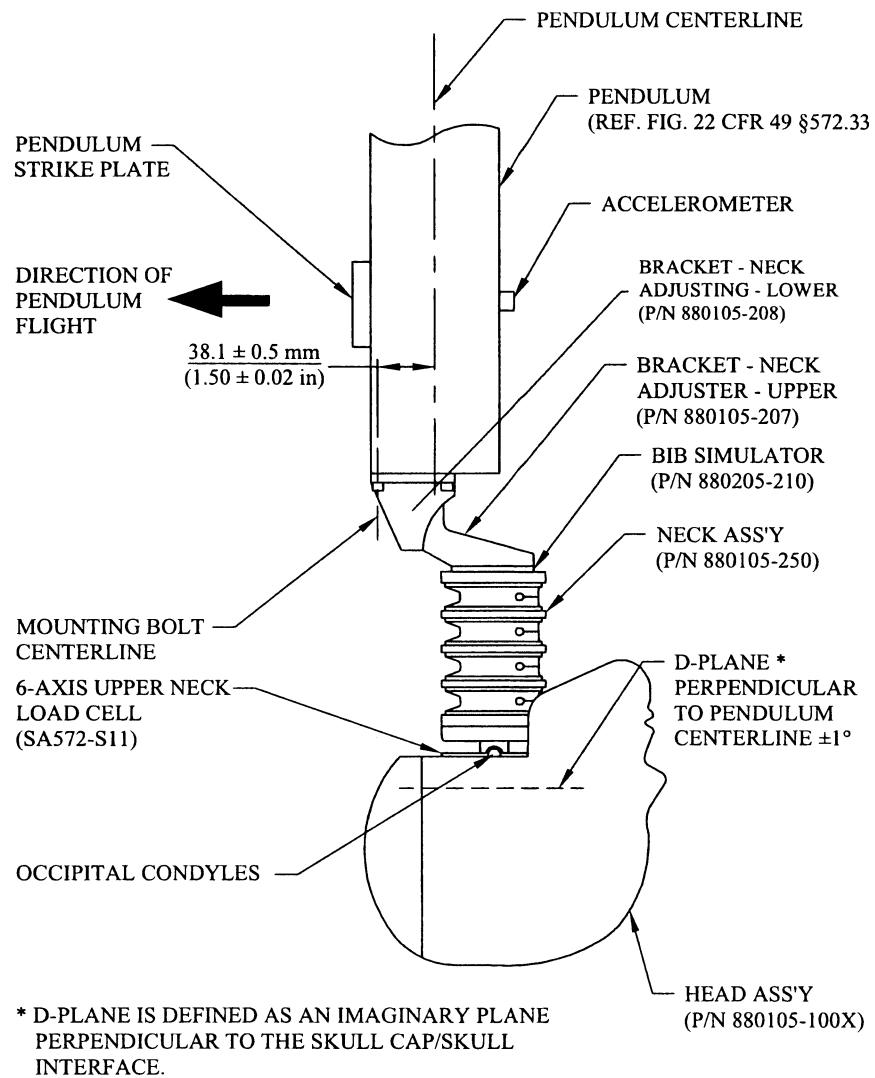
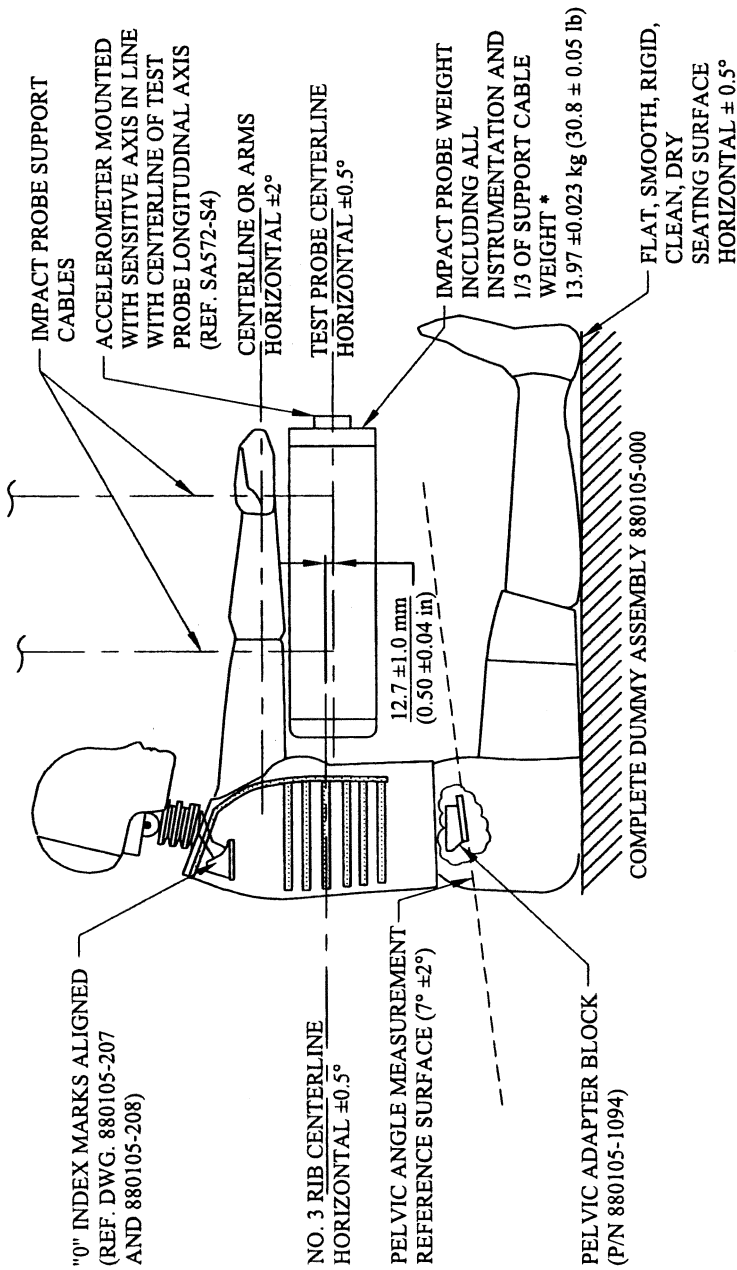
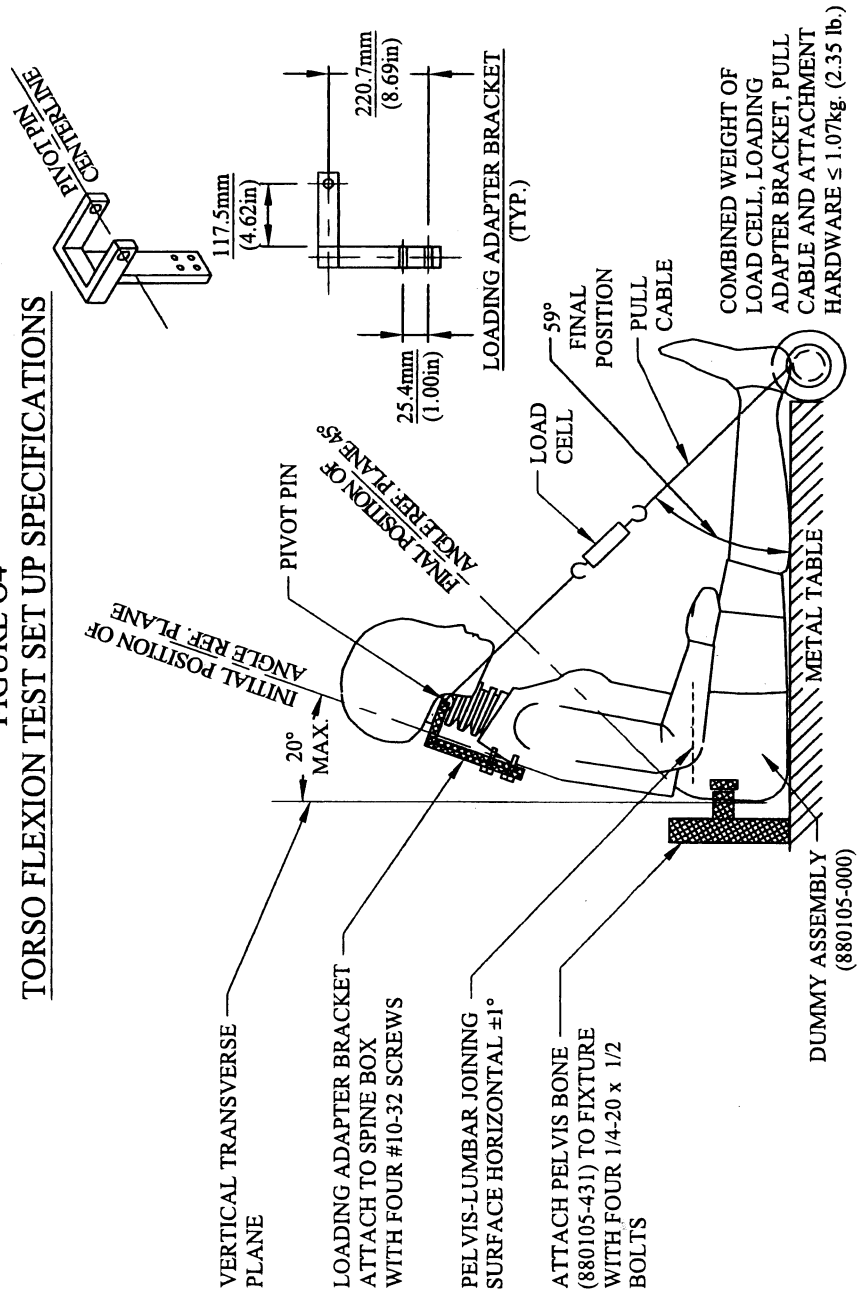


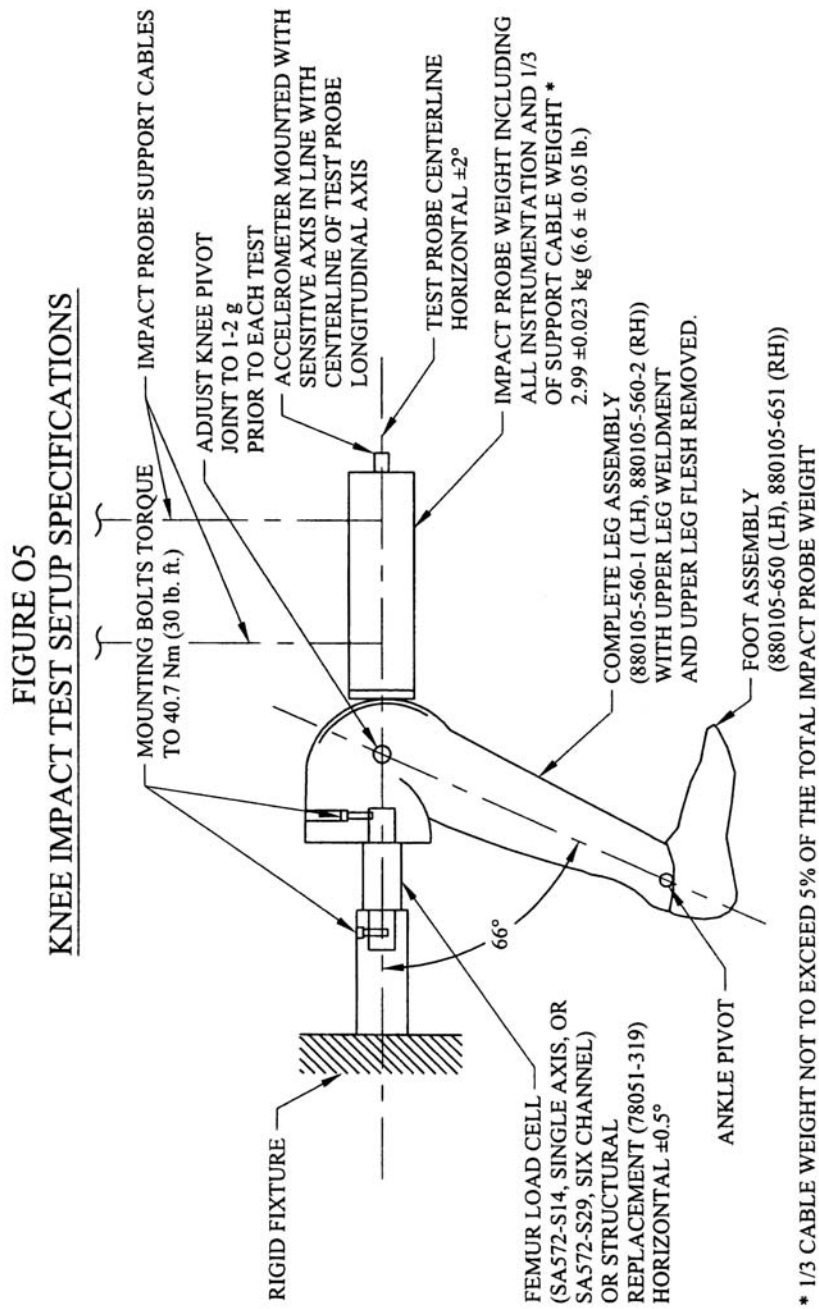
FIGURE O3
THORAX IMPACT TEST SETUP SPECIFICATIONS



* 1/3 CABLE WEIGHT NOT TO EXCEED 5% OF THE TOTAL IMPACT PROBE WEIGHT

FIGURE O4
TORSO FLEXION TEST SET UP SPECIFICATIONS





[65 FR 10968, Mar. 1, 2000, as amended at 67 FR 46415, July 15, 2002]

**Subpart P—3-year-Old Child
Crash Test Dummy, Alpha Version**

SOURCE: 65 FR 15262, Mar. 22, 2000, unless otherwise noted.

§ 572.140 Incorporation by reference.

(a) The following materials are hereby incorporated in this subpart P by reference:

(1) A drawings and specifications package entitled, "Parts List and Drawings, Subpart P Hybrid III 3-year-old child crash test dummy, (H-III3C, Alpha version) September 2001," incorporated by reference in § 572.141 and consisting of:

(i) Drawing No. 210-1000, Head Assembly, incorporated by reference in §§ 572.141, 572.142, 572.144, 572.145, and 572.146;

(ii) Drawing No. 210-2001, Neck Assembly, incorporated by reference in §§ 572.141, 572.143, 572.144, 572.145, and 572.146;

(iii) Drawing No. TE-208-000, Headform, incorporated by reference in §§ 572.141, and 572.143;

(iv) Drawing No. 210-3000, Upper/Lower Torso Assembly, incorporated by reference in §§ 572.141, 572.144, 572.145, and 572.146;

(v) Drawing No. 210-5000-1(L), -2(R), Leg Assembly, incorporated by reference in §§ 572.141, 572.144, 572.145 as part of a complete dummy assembly;

(vi) Drawing No. 210-6000-1(L), -2(R), Arm Assembly, incorporated by reference in §§ 572.141, 572.144, and 572.145 as part of the complete dummy assembly;

(2) A procedures manual entitled "Procedures for Assembly, Disassembly and Inspection (PADI), Subpart P, Hybrid III 3-year-old Child Crash Test Dummy, (H-III3C, Alpha Version) September 2001," incorporated by reference in § 572.141;

(3) SAE Recommended Practice J211/1, Rev. Mar 95 "Instrumentation for Impact Tests—Part 1-Electronic Instrumentation", incorporated by reference in § 572.146;

(4) SAE J1733 1994-12 "Sign Convention for Vehicle Crash Testing" incorporated by reference in § 572.146.

(5) The Director of the Federal Register approved those materials incorporated by reference in accordance

with 5 U.S.C. 552(a) and 1 CFR Part 51. Copies of the materials may be inspected at NHTSA's Docket Section, 400 Seventh Street SW, room 5109, Washington, DC, or at the National Archives and Records Administration (NARA). For information on the availability of this material at NARA, call 202-741-6030, or go to: http://www.archives.gov/federal_register/code_of_federal_regulations/ibr_locations.html.

(b) The incorporated materials are available as follows:

(1) The drawings and specifications package referred to in paragraph (a)(1) of this section and the PADI document referred to in paragraph (a)(2) of this section are accessible for viewing and copying at the Department of Transportation's Docket public area, Plaza 401, 400 Seventh St., SW., Washington, DC 20590, and downloadable at dms.dot.gov. They are also available from Reprographic Technologies, 9107 Gaither Rd., Gaithersburg, MD 20877, (301) 419-5070.

(2) The SAE materials referred to in paragraphs (a)(3) and (a)(4) of this section are available from the Society of Automotive Engineers, Inc., 400 Commonwealth Drive, Warrendale, PA 15096.

[65 FR 15262, Mar. 22, 2000, as amended at 66 FR 64376, Dec. 13, 2001]

§ 572.141 General description.

(a) The Hybrid III 3-year-old child dummy is described by the following materials:

(1) Technical drawings and specifications package 210-0000 (refer to § 572.140(a)(1)), the titles of which are listed in Table A of this section;

(2) Procedures for Assembly, Disassembly and Inspection document (PADI) (refer to § 572.140(a)(2)).

(b) The dummy is made up of the component assemblies set out in the following Table A of this section:

TABLE A

Component assembly	Drawing No.
Head Assembly	210-1000
Neck Assembly (complete)	210-2001
Upper/Lower Torso Assembly	210-3000
Leg Assembly	210-5000-1(L), -2(R)

TABLE A—Continued

Component assembly	Drawing No.
Arm Assembly	210-6000-1(L), -2(R)

(c) Adjacent segments are joined in a manner such that except for contacts existing under static conditions, there is no contact between metallic elements throughout the range of motion or under simulated crash impact conditions.

(d) The structural properties of the dummy are such that the dummy conforms to this part in every respect only before use in any test similar to those specified in Standard 208, *Occupant Crash Protection*, and Standard 213, *Child Restraint Systems*.

§ 572.142 Head assembly and test procedure.

(a) The head assembly (refer to § 572.140(a)(1)(i)) for this test consists of the head (drawing 210-1000), adapter plate (drawing ATD 6259), accelerometer mounting block (drawing SA 572-S80), structural replacement of ½ mass of the neck load transducer (drawing TE-107-001), head mounting washer (drawing ATD 6262), one ½-20x1" flat head cap screw (FHCS) (drawing 9000150), and 3 accelerometers (drawing SA-572-S4).

(b) When the head assembly in paragraph (a) of this section is dropped from a height of 376.0±1.0 mm (14.8±0.04 in) in accordance with paragraph (c) of this section, the peak resultant acceleration at the location of the accelerometers at the head CG shall not be less than 250 g or more than 280 g. The resultant acceleration versus time history curve shall be unimodal, and the oscillations occurring after the main pulse shall be less than 10 percent of the peak resultant acceleration. The lateral acceleration shall not exceed ±15 G (zero to peak).

(c) *Head test procedure.* The test procedure for the head is as follows:

(1) Soak the head assembly in a controlled environment at any temperature between 18.9 and 25.6 °C (66 and 78 °F) and at any relative humidity between 10 and 70 percent for at least four hours prior to a test.

(2) Prior to the test, clean the impact surface of the head skin and the steel impact plate surface with isopropyl alcohol, trichlorethane, or an equivalent. Both impact surfaces must be clean and dry for testing.

(3) Suspend the head assembly with its midsagittal plane in vertical orientation as shown in Figure P1 of this subpart. The lowest point on the forehead is 376.0 ±1.0 mm (14.76 ±0.04 in) from the steel impact surface. The 3.3 mm (0.13 in) diameter holes, located on either side of the dummy's head in transverse alignment with the CG, shall be used to ensure that the head transverse plane is level with respect to the impact surface.

(4) Drop the head assembly from the specified height by a means that ensures a smooth, instant release onto a rigidly supported flat horizontal steel plate which is 50.8 mm (2 in) thick and 610 mm (24 in) square. The impact surface shall be clean, dry and have a finish of not less than 203.2x10⁻⁶ mm (8 micro inches) (RMS) and not more than 2032.0x10⁻⁶ mm (80 micro inches) (RMS).

(5) Allow at least 2 hours between successive tests on the same head.

§ 572.143 Neck-headform assembly and test procedure.

(a) The neck and headform assembly (refer to §§ 572.140(a)(1)(ii) and 572.140(a)(1)(iii)) for the purposes of this test, as shown in Figures P2 and P3 of this subpart, consists of the neck molded assembly (drawing 210-2015), neck cable (drawing 210-2040), nylon shoulder bushing (drawing 9001373), upper mount plate insert (drawing 910420-048), bib simulator (drawing TE-208-050), urethane washer (drawing 210-2050), neck mounting plate (drawing TE-250-021), two jam nuts (drawing 9001336), load-moment transducer (drawing SA 572-S19), and headform (drawing TE-208-000).

(b) When the neck and headform assembly, as defined in § 572.143(a), is tested according to the test procedure in paragraph (c) of this section, it shall have the following characteristics:

(1) Flexion.

(i) Plane D, referenced in Figure P2 of this subpart, shall rotate in the direction of preimpact flight with respect to the pendulum's longitudinal centerline between 70 degrees and 82 degrees. Within this specified rotation corridor, the peak moment about the occipital condyle may not be less than 42 N-m and not more than 53 N-m.

(ii) The positive moment shall decay for the first time to 10 N-m between 60 ms and 80 ms after time zero.

(iii) The moment and rotation data channels are defined to be zero when the longitudinal centerline of the neck and pendulum are parallel.

(2) Extension.

(i) Plane D referenced in Figure P3 of this subpart shall rotate in the direction of preimpact flight with respect to the pendulum's longitudinal centerline between 83 degrees and 93 degrees. Within this specified rotation corridor, the peak moment about the occipital condyle may be not more than -43.7 N-m and not less than -53.3 N-m.

(ii) The negative moment shall decay for the first time to -10 N-m between 60 and 80 ms after time zero.

(iii) The moment and rotation data channels are defined to be zero when the longitudinal centerline of the neck and pendulum are parallel.

(c) *Test procedure.* (1) Soak the neck assembly in a controlled environment at any temperature between 20.6 and 22.2 °C (69 and 72 F) and a relative hu-

midity between 10 and 70 percent for at least four hours prior to a test.

(2) Torque the jam nut (drawing 9001336) on the neck cable (drawing 210-2040) between 0.2 N-m and 0.3 N-m.

(3) Mount the neck-headform assembly, defined in paragraph (a) of this section, on the pendulum so the midsagittal plane of the headform is vertical and coincides with the plane of motion of the pendulum as shown in Figure P2 of this subpart for flexion and Figure P3 of this subpart for extension tests.

(4) Release the pendulum and allow it to fall freely to achieve an impact velocity of 5.50 ±0.10 m/s (18.05 + 0.40 ft/s) for flexion and 3.65 ±0.1 m/s (11.98 ±0.40 ft/s) for extension tests, measured by an accelerometer mounted on the pendulum as shown in Figure 22 of this part 572 at time zero.

(i) The test shall be conducted without inducing any torsion twisting of the neck.

(ii) Stop the pendulum from the initial velocity with an acceleration vs. time pulse which meets the velocity change as specified in Table B of this section. Integrate the pendulum acceleration data channel to obtain the velocity vs. time curve as indicated in Table B of this section.

(iii) Time-zero is defined as the time of initial contact between the pendulum striker plate and the honeycomb material. The pendulum data channel shall be zero at this time.

TABLE B—PENDULUM PULSE

Time ms	Flexion		Time ms	Extension	
	m/s	ft/s		m/s	ft/s
10	2.0-2.7	6.6-8.9	6	1.0-1.4	3.3-4.6
15	3.0-4.0	9.8-13.1	10	1.9-2.5	6.2-8.2
20	4.0-5.1	13.1-16.7	14	2.8-3.5	9.2-11.5

§ 572.144 **Thorax assembly and test procedure.**

(a) *Thorax (upper torso) assembly (refer to § 572.140(a)(1)(iv)).* The thorax consists of the upper part of the torso assembly shown in drawing 210-3000.

(b) When the anterior surface of the thorax of a completely assembled dummy (drawing 210-0000) is impacted by a test probe conforming to

§ 572.146(a) at 6.0 ±0.1 m/s (19.7 ±0.3 ft/s) according to the test procedure in paragraph (c) of this section.

(1) Maximum sternum displacement (compression) relative to the spine, measured with the chest deflection transducer (SA-572-S50), must not be less than 32mm (1.3 in) and not more than 38mm (1.5 in). Within this specified compression corridor, the peak force, measured by the probe-mounted

§572.145

accelerometer as defined in §572.146(a) and calculated in accordance with paragraph (b)(3) of this section, shall be not less than 680 N and not more than 810 N. The peak force after 12.5 mm of sternum compression but before reaching the minimum required 32.0 mm sternum compression shall not exceed 910 N.

(2) The internal hysteresis of the ribcage in each impact, as determined from the force vs. deflection curve, shall be not less than 65 percent and not more than 85 percent. The hysteresis shall be calculated by determining the ratio of the area between the loading and unloading portions of the force deflection curve to the area under the loading portion of the curve.

(3) The force shall be calculated by the product of the impactor mass and its deceleration.

(c) *Test procedure.* The test procedure for the thorax assembly is as follows:

(1) The test dummy is clothed in cotton-polyester-based tight-fitting shirt with long sleeves and ankle-length pants whose combined weight is not more than 0.25 kg (0.55 lbs).

(2) Soak the dummy in a controlled environment at any temperature between 20.6 and 22.2 °C (69 and 72 °F) and at any relative humidity between 10 and 70 percent for at least four hours prior to a test.

(3) Seat and orient the dummy on a seating surface without back support as shown in Figure P4, with the lower limbs extended horizontally and forward, the upper arms parallel to the torso and the lower arms extended horizontally and forward, parallel to the midsagittal plane, the midsagittal plane being vertical within ±1 degree and the ribs level in the anterior-posterior and lateral directions within ±0.5 degrees.

(4) Establish the impact point at the chest midsagittal plane so that the impact point of the longitudinal centerline of the probe coincides with the dummy's mid-sagittal plane and is centered on the center of No. 2 rib within ±2.5 mm (0.1 in.) and 0.5 degrees of a horizontal plane.

(5) Impact the thorax with the test probe so that at the moment of contact the probe's longitudinal center line is

49 CFR Ch. V (10–1–10 Edition)

within 2 degrees of a horizontal line in the dummy's midsagittal plane.

(6) Guide the test probe during impact so that there is no significant lateral, vertical or rotational movement.

(7) No suspension hardware, suspension cables, or any other attachments to the probe, including the velocity vane, shall make contact with the dummy during the test.

[65 FR 15262, Mar. 22, 2000, as amended at 66 FR 64376, Dec. 13, 2001]

§572.145 Upper and lower torso assemblies and torso flexion test procedure.

(a) The test objective is to determine the resistance of the lumbar spine and abdomen of a fully assembled dummy (drawing 210-0000) to flexion articulation between upper and lower halves of the torso assembly (refer to §572.140(a)(1)(iv)).

(b)(1) When the upper half of the torso assembly of a seated dummy is subjected to a force continuously applied at the occipital condyle level through the rigidly attached adaptor bracket in accordance with the test procedure set out in paragraph (c) of this section, the lumbar spine-abdomen assembly shall flex by an amount that permits the upper half of the torso, as measured at the posterior surface of the torso reference plane shown in Figure P5 of this subpart, to translate in angular motion in the midsagittal plane 45 ±0.5 degrees relative to the vertical transverse plane, at which time the pulling force applied must not be less than 130 N (28.8 lbf) and not more than 180 N (41.2 lbf), and

(2) Upon removal of the force, the upper torso assembly returns to within 10 degrees of its initial position.

(c) *Test procedure.* The test procedure is as follows:

(1) Soak the dummy in a controlled environment at any temperature between 18.9° and 25.6 °C (66 and 78 °F) and at any relative humidity between 10 and 70 percent for at least 4 hours prior to a test.

(2) Assemble the complete dummy (with or without the lower legs) and seat it on a rigid flat-surface table, as shown in Figure P5 of this subpart.

(i) Unzip the torso jacket and remove the four ¼-20×¾" bolts which attach

the lumbar load transducer or its structural replacement to the pelvis weldment (drawing 210-4510) as shown in Figure P5 of this subpart.

(ii) Position the matching end of the rigid pelvis attachment fixture around the lumbar spine and align it over the four bolt holes.

(iii) Secure the fixture to the dummy with the four ¼-20×¾" bolts and attach the fixture to the table. Tighten the mountings so that the pelvis-lumbar joining surface is horizontal within ±1 deg and the buttocks and upper legs of the seated dummy are in contact with the test surface.

(iv) Attach the loading adapter bracket to the upper part of the torso as shown in Figure P5 of this subpart and zip up the torso jacket.

(v) Point the upper arms vertically downward and the lower arms forward.

(3)(i) Flex the thorax forward three times from vertical until the torso reference plane reaches 30 ±2 degrees from vertical. The torso reference plane, as shown in figure P5 of this subpart, is defined by the transverse plane tangent to the posterior surface of the upper backplate of the spine box weldment (drawing 210-8020).

(ii) Remove all externally applied flexion forces and support the upper torso half in a vertical orientation for 30 minutes to prevent it from drooping.

(4) Remove the external support and after two minutes measure the initial orientation angle of the upper torso reference plane of the seated, unsupported dummy as shown in Figure P5 of this subpart. The initial orientation of the torso reference plane may not exceed 15 degrees.

(5) Attach the pull cable at the point of load application on the adaptor bracket while maintaining the initial torso orientation. Apply a pulling force in the midsagittal plane, as shown in Figure P5 of this subpart, at any upper torso flexion rate between 0.5 and 1.5 degrees per second, until the torso reference plane reaches 45 ±0.5 degrees of flexion relative to the vertical transverse plane.

(6) Continue to apply a force sufficient to maintain 45 ±0.5 degrees of flexion for 10 seconds, and record the highest applied force during the 10-second period.

(7) [Reserved]

(8) Release all force at the loading adaptor bracket as rapidly as possible and measure the return angle with respect to the initial angle reference plane as defined in paragraph (c)(4) of this section 3 to 4 minutes after the release.

§ 572.146 Test conditions and instrumentation.

(a) The test probe for thoracic impacts, except for attachments, shall be of rigid metallic construction and concentric about its longitudinal axis. Any attachments to the impactor such as suspension hardware, and impact vanes, must meet the requirements of § 572.144(c)(7) of this part. The impactor shall have a mass of 1.70 ±0.02 kg (3.75 ±0.05 lb) and a minimum mass moment of inertia 164 kg-cm² (0.145 lb-in-sec²) in yaw and pitch about the CG of the probe. One-third (⅓) of the weight of suspension cables and any attachments to the impact probe must be included in the calculation of mass, and such components may not exceed five percent of the total weight of the test probe. The impacting end of the probe, perpendicular to and concentric with the longitudinal axis of the probe, has a flat, continuous, and non-deformable 50.8 ±0.25 mm (2.00 ±0.01 inch) diameter face with an edge radius of 7.6/12.7 mm (0.3/0.5 in). The impactor shall have a 53.3 mm (2.1 in) dia. cylindrical surface extending for a minimum of 25.4 mm (1.0 in) to the rear from the impact face. The probe's end opposite to the impact face has provisions for mounting an accelerometer with its sensitive axis collinear with the longitudinal axis of the probe. The impact probe has a free air resonant frequency not less than 1000 Hz limited to the direction of the longitudinal axis of the impactor.

(b) Head accelerometers shall have the dimensions, response characteristics, and sensitive mass locations specified in drawing SA 572-S4 and be mounted in the head as shown in drawing 210-0000.

(c) The neck force-moment transducer shall have the dimensions, response characteristics, and sensitive axis locations specified in drawing SA 572-S19 and be mounted at the upper neck transducer location as shown in

§572.146

49 CFR Ch. V (10–1–10 Edition)

drawing 210–0000. A lower neck transducer as specified in drawing SA 572–S19 is allowed to be mounted as optional instrumentation in place of part No. ATD6204, as shown in drawing 210–0000.

(d) The shoulder force transducers shall have the dimensions and response characteristics specified in drawing SA 572–S21 and be allowed to be mounted as optional instrumentation in place of part No. 210–3800 in the torso assembly as shown in drawing 210–0000.

(e) The thorax accelerometers shall have the dimensions, response characteristics, and sensitive mass locations specified in drawing SA 572–S4 and be mounted in the torso assembly in triaxial configuration at the T4 location, as shown in drawing 210–0000. Triaxial accelerometers may be mounted as optional instrumentation at T1, and T12, and in uniaxial configuration on the sternum at the midpoint level of ribs No. 1 and No. 3 and on the spine coinciding with the midpoint level of No. 3 rib, as shown in drawing 210–0000. If used, the accelerometers must conform to SA–572–S4.

(f) The chest deflection potentiometer shall have the dimensions and response characteristics specified in drawing SA–572–S50 and be mounted in the torso assembly as shown drawing 210–0000.

(g) The lumbar spine force/moment transducer may be mounted in the torso assembly as shown in drawing 210–0000 as optional instrumentation in place of part No. 210–4150. If used, the transducer shall have the dimensions and response characteristics specified in drawing SA–572–S20.

(h) The pubic force transducer may be mounted in the torso assembly as shown in drawing 210–0000 as optional instrumentation in place of part No. 921–0022–036. If used, the transducer shall have the dimensions and response characteristics specified in drawing SA–572–S18.

(i) The acetabulum force transducers may be mounted in the torso assembly as shown in drawing 210–0000 as optional instrumentation in place of part No. 210–4522. If used, the transducer shall have the dimensions and response characteristics specified in drawing SA–572–S22.

(j) The anterior-superior iliac spine transducers may be mounted in the torso assembly as shown in drawing 210–0000 as optional instrumentation in place of part No. 210–4540–1, –2. If used, the transducers shall have the dimensions and response characteristics specified in drawing SA–572–S17.

(k) The pelvis accelerometers may be mounted in the pelvis in triaxial configuration as shown in drawing 210–0000 as optional instrumentation. If used, the accelerometers shall have the dimensions and response characteristics specified in drawing SA–572–S4.

(l) The outputs of acceleration and force-sensing devices installed in the dummy and in the test apparatus specified by this part shall be recorded in individual data channels that conform to the requirements of SAE Recommended Practice J211/1, Rev. Mar 95 “Instrumentation for Impact Tests—Part 1–Electronic Instrumentation” (refer to §572.140(a)(3)), with channel classes as follows:

- (1) Head acceleration—Class 1000
- (2) Neck
 - (i) Force—Class 1000
 - (ii) Moments—Class 600
 - (iii) Pendulum acceleration—Class 180
 - (iv) Rotation potentiometer response (if used)—CFC 60.
- (3) Thorax:
 - (i) Rib/sternum acceleration—Class 1000
 - (ii) Spine and pendulum accelerations—Class 180
 - (iii) Sternum deflection—Class 600
 - (iv) Shoulder force—Class 180
- (4) Lumbar:
 - (i) Forces—Class 1000
 - (ii) Moments—Class 600
 - (iii) Torso flexion pulling force—Class 60 if data channel is used
- (5) Pelvis
 - (i) Accelerations—Class 1000
 - (ii) Acetabulum, pubic symphysis—Class 1000,
 - (iii) Iliac wing forces—Class 180
- (m) Coordinate signs for instrumentation polarity shall conform to the Sign Convention For Vehicle Crash Testing, Surface Vehicle Information Report, SAE J1733, 1994–12 (refer to §572.140(a)(4)).
- (n) The mountings for sensing devices shall have no resonance frequency less

Nat'l Highway Traffic Safety Admin., DOT

Pt. 572, Subpt. P, Figs.

than 3 times the frequency range of the applicable channel class.

(o) Limb joints shall be set at 1G, barely restraining the weight of the limbs when they are extended horizontally. The force required to move a limb segment shall not exceed 2G throughout the range of limb motion.

(p) Performance tests of the same component, segment, assembly, or

fully assembled dummy shall be separated in time by a period of not less than 30 minutes unless otherwise noted.

(q) Surfaces of dummy components are not painted except as specified in this part or in drawings subtended by this part.

FIGURES TO SUBPART P OF PART 572

Figure P1
HEAD DROP TEST SET-UP SPECIFICATIONS

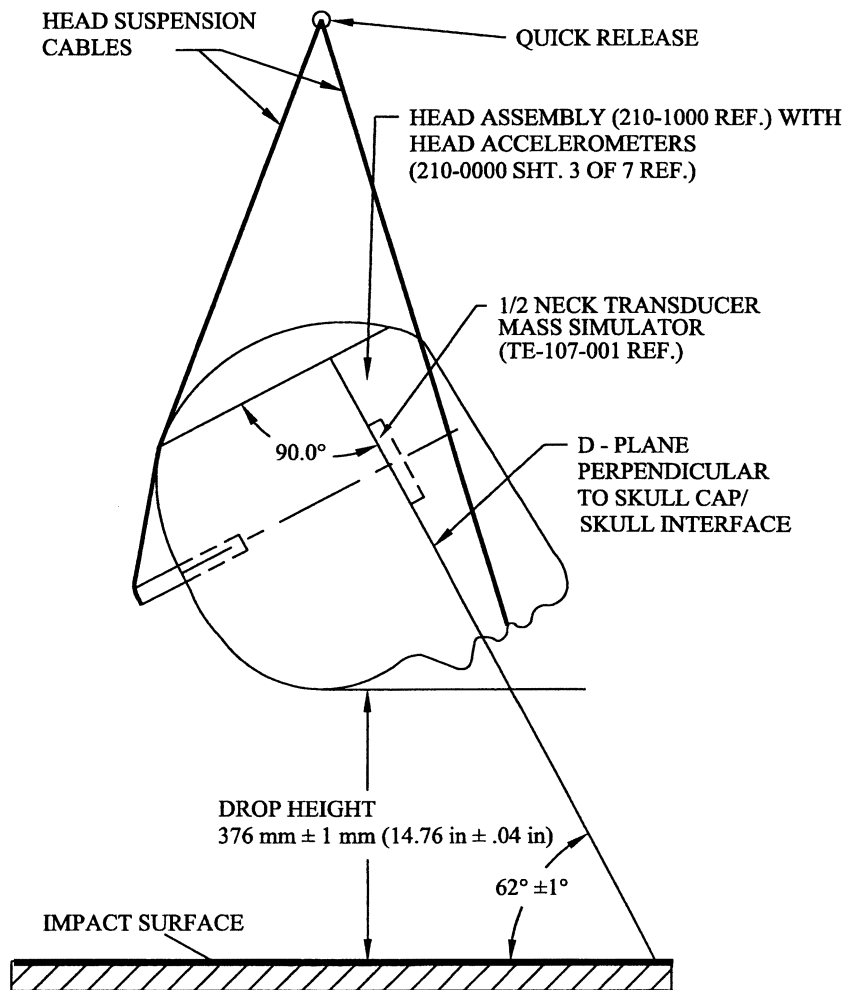
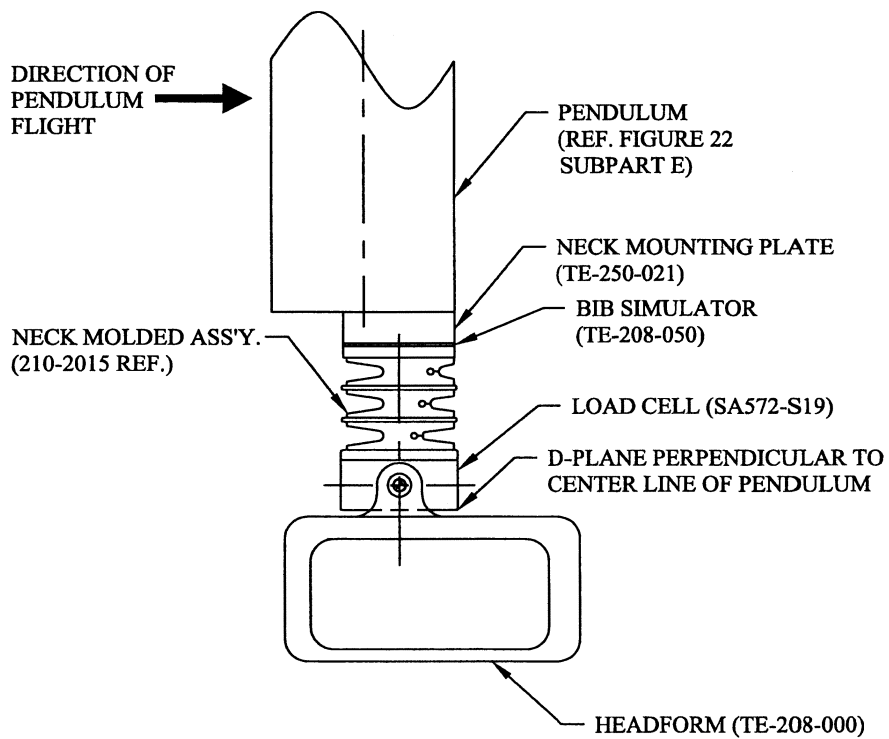
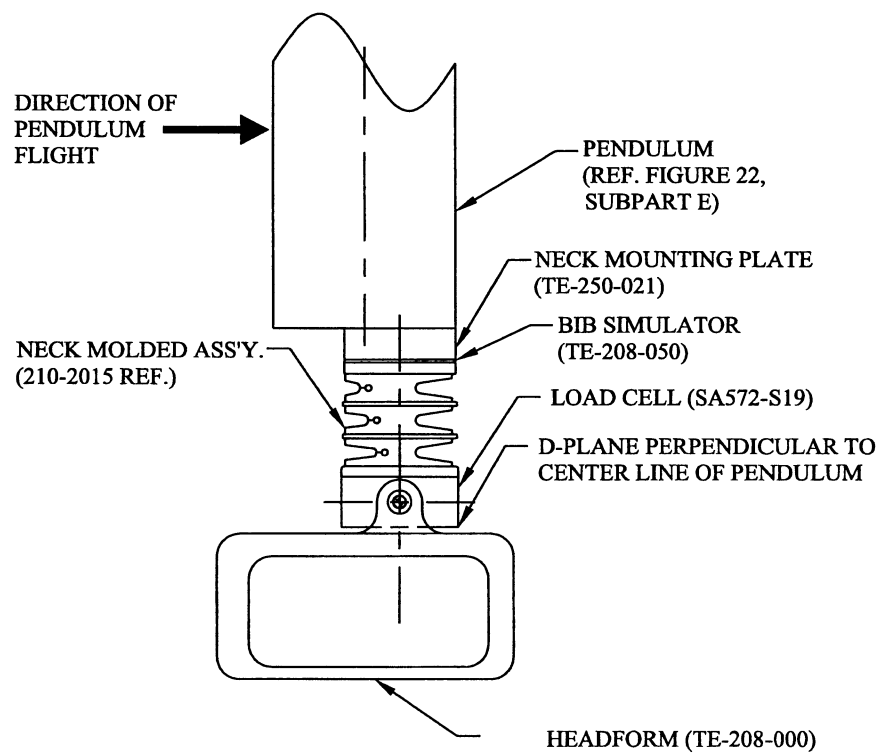


Figure P2
NECK FLEXION TEST SET-UP SPECIFICATIONS



NOTE: MOUNT NECK AT LEADING EDGE OF PENDULUM TO AVOID INTERFERENCE WITH HEADFORM MOTION. PENDULUM SHOWN IN VERTICAL ORIENTATION.

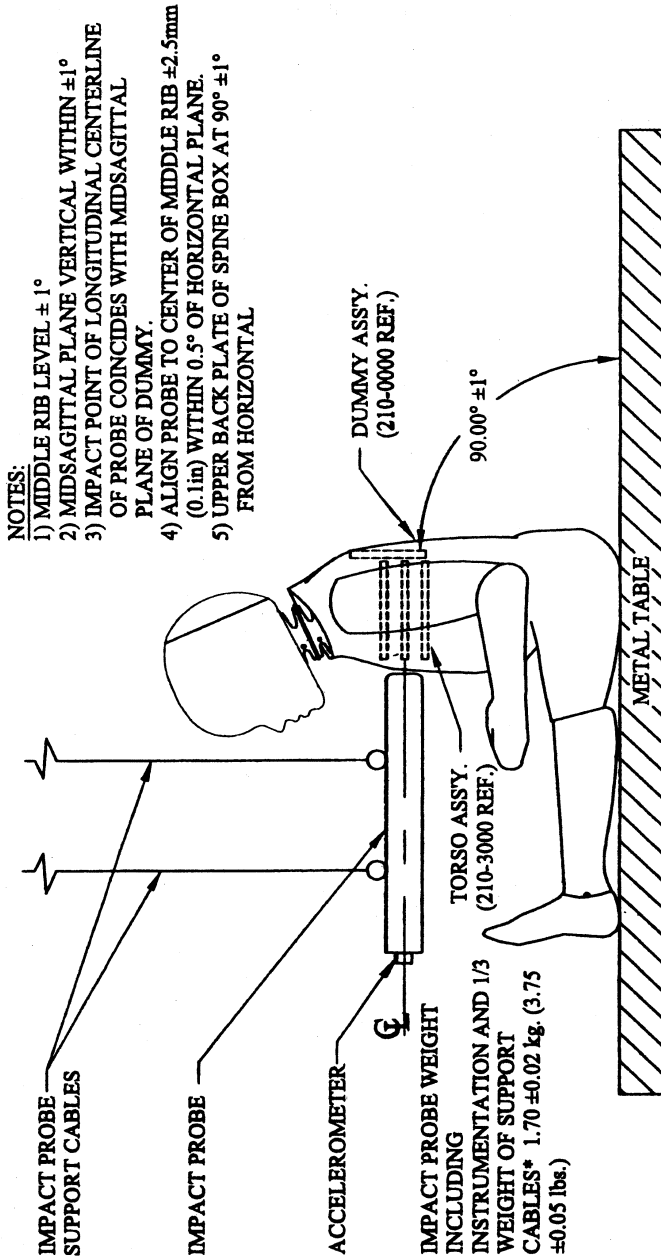
Figure P3
NECK EXTENSION TEST SET-UP SPECIFICATIONS



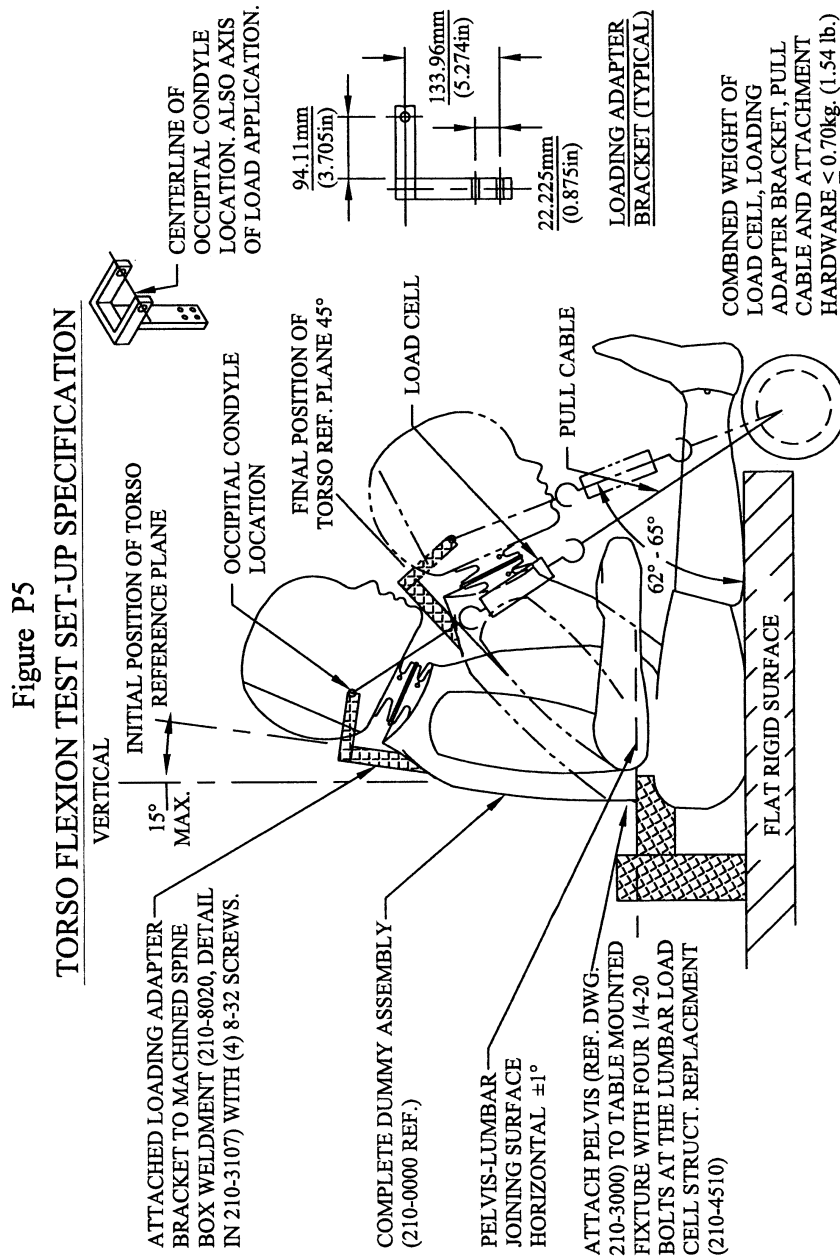
NOTE: MOUNT NECK AT LEADING EDGE OF PENDULUM TO AVOID
INTERFERENCE WITH HEADFORM MOTION.
PENDULUM SHOWN IN VERTICAL ORIENTATION.

Figure P4

THORAX IMPACT TEST SET-UP SPECIFICATIONS



* 1/3 WEIGHT OF PROBE SUPPORT CABLES AND THEIR ATTACHMENTS TO THE IMPACT PROBE NOT TO EXCEED 5% OF THE TOTAL IMPACT PROBE WEIGHT.



[65 FR 15262, Mar. 22, 2000, as amended at 66 FR 64376, Dec. 13, 2001]

Subpart R—CRABI 12-Month-Old Infant, Alpha Version

SOURCE: 65 FR 17188, Mar. 31, 2000, unless otherwise noted.

§ 572.150 Incorporation by reference.

(a) The following materials are incorporated by reference in this subpart R.

(1) A drawings and specifications package entitled “Parts List and Drawings, Subpart R, CRABI 12-Month-Old Infant Crash Test Dummy (CRABI-12, Alpha version) August 2001” and consisting of:

(i) Drawing No. 921022-001, Head Assembly, incorporated by reference in §§ 572.151, 572.152, 572.154, and 572.155;

(ii) Drawing No. 921022-041, Neck Assembly, incorporated by reference in §§ 572.151, 572.153, 572.154, and 572.155;

(iii) Drawing No. TE-3200-160, Headform, incorporated by reference in §§ 572.151 and 572.153;

(iv) Drawing No. 921022-060, Torso Assembly, incorporated by reference in §§ 572.151, 572.154, and 572.155;

(v) Drawing No. 921022-055, Leg Assembly, incorporated by reference in §§ 572.151, and 572.155 as part of a complete dummy assembly;

(vi) Drawing No. 921022-054, Arm Assembly, incorporated by reference in §§ 572.151, and 572.155 as part of the complete dummy assembly;

(2) A procedures manual entitled “Procedures for Assembly, Disassembly and Inspection (PADI) Subpart R, CRABI 12-Month-Old Infant Crash Test Dummy (CRABI-12, Alpha version) August 2001” incorporated by reference in § 572.155;

(3) SAE Recommended Practice J211/1, Rev. Mar95 “Instrumentation for Impact Tests—Part 1—Electronic Instrumentation”, incorporated by reference in § 572.155;

(4) SAE J1733 1994-12 “Sign Convention for Vehicle Crash Testing”, incorporated by reference in § 572.155.

(b) The Director of the Federal Register approved those materials incorporated by reference in accordance with 5 U.S.C. 552(a) and 1 CFR Part 51. Copies of the materials may be inspected at NHTSA’s Docket Section, 400 Seventh Street S.W., room 5109, Washington, DC, or at the National Archives and Records Administration

(NARA). For information on the availability of this material at NARA, call 202-741-6030, or go to: http://www.archives.gov/federal_register/code_of_federal_regulations/ibr_locations.html.

(c) The incorporated materials are available as follows:

(1) The drawings and specifications package referred to in paragraph (a)(1) of this section and the procedures manual referred to in paragraph (a)(2) of this section are available from Reprographic Technologies, 9000 Virginia Manor Road, Beltsville, MD 20705 (301) 419-5070.

(2) The SAE materials referred to paragraphs (a)(3) and (a)(4) of this section are available from the Society of Automotive Engineers, Inc., 400 Commonwealth Drive, Warrendale, PA 15096.

[65 FR 17188, Mar. 31, 2000, as amended at 66 FR 45784, Aug. 30, 2001]

§ 572.151 General description.

(a) The 12-month-old-infant crash test dummy is described by drawings and specifications containing the following materials:

(1) Technical drawings and specifications package 921022-000 (refer to § 572.150(a)(1)), the titles of which are listed in Table A of this section;

(2) Procedures for Assembly, Disassembly and Inspection document (PADI) (refer to § 572.150(a)(2)).

(b) The dummy consists of the component assemblies set out in the following Table A:

TABLE A

Component assembly	Drawing number
Head Assembly	921022-001.
Neck Assembly (complete)	921022-041.
Torso Assembly	921022-060.
Leg Assembly	921022-055 R&L.
Arm Assembly	921022-054 R&L.

(c) Adjacent segments of the dummy are joined in a manner such that, except for contacts existing under static conditions, there is no contact between metallic elements throughout the range of motion or under simulated crash impact conditions.

(d) The structural properties of the dummy are such that the dummy shall

§572.152

conform to this Subpart in every respect before its use in any test under this chapter.

§572.152 Head assembly and test procedure.

(a) The head assembly (refer to §572.150(a)(1)(i)) for this test consists of the assembly (drawing 921022-001), triaxial mount block (SA572-80), and 3 accelerometers (drawing SA572-S4).

(b) *Frontal and rear impact.* (1) *Frontal impact.* When the head assembly in paragraph (a) of this section is dropped from a height of 376.0 ±1.0 mm (14.8 ±0.04 in) in accordance with paragraph (c)(3)(i) of this section, the peak resultant acceleration measured at the head CG shall not be less than 100 g or more than 120 g. The resultant acceleration vs. time history curve shall be unimodal, and the oscillations occurring after the main pulse shall be less than 17 percent of the peak resultant acceleration. The lateral acceleration shall not exceed ±15 g's.

(2) *Rear impact.* When the head assembly in paragraph (a) of this section is dropped from a height of 376.0 ±1.0 mm (14.8 ±0.04 in) in accordance with paragraph (c)(3)(ii) of this section, the peak resultant acceleration measured at the head CG shall be not less than 55 g and not more than 71 g. The resultant acceleration vs. time history curve shall be unimodal, and the oscillations occurring after the main pulse shall be less than 17 percent of the peak resultant acceleration. The lateral acceleration shall not exceed ±15 g's.

(c) *Head test procedure.* The test procedure for the head is as follows:

(1) Soak the head assembly in a controlled environment at any temperature between 18.9 and 25.6 °C (66 and 78 °F) and at any relative humidity between 10 and 70 percent for at least four hours prior to a test. These temperature and humidity levels shall be maintained throughout the entire testing period specified in this section.

(2) Before the test, clean the impact surface of the head skin and the steel impact plate surface with isopropyl alcohol, trichlorethane, or an equivalent. Both impact surfaces shall be clean and dry for testing.

(3)(i) For a frontal impact test, suspend the head assembly with its

49 CFR Ch. V (10-1-10 Edition)

midsagittal plane in vertical orientation as shown in Figure R1 of this subpart. The lowest point on the forehead is 376.0 ±1.0 mm (14.8 ±0.04 in) from the impact surface. The 3.30 mm (0.13 in) diameter holes located on either side of the dummy's head are used to ensure that the head is level with respect to the impact surface. The angle between the lower surface plane of the neck transducer mass simulator (drawing 910420-003) and the plane of the impact surface is 45 ±1 degrees.

(ii) For a rear impact test, suspend the head assembly with its midsagittal plane in vertical orientation as shown in Figure R2 of this subpart. The lowest point on the back of the head is 376.0 ±1.0 mm (14.8 ±0.04 in) from the impact surface. The 3.30 mm (0.13 in) diameter holes located on either side of the dummy's head are used to ensure that the head is level with respect to the impact surface. The angle between the lower surface plane of the neck transducer structural replacement (drawing 910420-003) and the impact surface is 90 ±1 degrees.

(4) Drop the head assembly from the specified height by a means that ensures a smooth, instant release onto a rigidly supported flat horizontal steel plate which is 50.8 mm (2 in) thick and 610 mm (24 in) square. The impact surface shall be clean, dry and have a micro finish of not less than 203.2×10^{-6} mm (8 micro inches) (RMS) and not more than 2032.0×10^{-6} mm (80 micro inches) (RMS).

(5) Allow at least 2 hours between successive tests of the head assembly at the same impact point. For head impacts on the opposite side of the head, the 30-minute waiting period specified in §572.155(m) does not apply.

§572.153 Neck-headform assembly and test procedure.

(a) The neck and headform assembly (refer to §§572.150(a)(1)(ii) and 572.150(a)(1)(iii)) for the purposes of this test consists of parts shown in CRABI neck test assembly (drawing TE-3200-100);

(b) When the neck and headform assembly, as defined in §572.153(a), is tested according to the test procedure in §572.153(c), it shall have the following characteristics:

(1) *Flexion.* (i) Plane D referenced in Figure R3 of this subpart shall rotate in the direction of pre-impact flight with respect to the pendulum's longitudinal centerline not less than 75 degrees and not more than 86 degrees. Within this specified rotation corridor, the peak positive moment about the occipital condyles shall be not less than 36 N-m (26.6 ft-lbf) and not more than 45 N-m (33.2 ft-lbf).

(ii) The positive moment about the occipital condyles shall decay for the first time to 5 N-m (3.7 ft-lbf) between 60 ms and 80 ms after time zero.

(iii) The moment about the occipital condyles shall be calculated by the following formula: $Moment (N-m) = My - (0.005842m) \times (Fx)$, where My is the moment about the y-axis, Fx is the shear force measured by the neck transducer (drawing SA572 -S23) and 0.005842m is the distance from the point at which the load cell measures the force to the occipital condyle.

(2) *Extension.* (i) Plane D referenced in Figure R4 of this subpart shall rotate in the direction of preimpact flight with respect to the pendulum's longitudinal centerline not less than 80 degrees and not more than 92 degrees. Within the specified rotation corridor, the peak negative moment about the occipital condyles shall be not more than -12 Nm (-8.9 ft-lbf) and not less than -23 N-m (-17.0 ft-lbf) within the minimum and maximum rotation interval.

(ii) The negative moment about the occipital condyles shall decay for the first time to -5 Nm (-3.7 lbf-ft) between 76 ms and 90 ms after time zero.

(iii) The moment about the occipital condyles shall be calculated by the following formula: $Moment (N-m) = My - (0.005842m) \times (Fx)$, where My is the moment about the y-axis, Fx is the shear force measured by the neck transducer (drawing SA572 -S23) and 0.005842m is

the distance from the point at which the load cell measures the force to the occipital condyle.

(c) *Test procedure.* (1) Soak the neck assembly in a controlled environment at any temperature between 20.6 and 22.2 °C (69 and 72 °F) and at any relative humidity between 10 and 70 percent for at least four hours prior to a test. These temperature and humidity levels shall be maintained throughout the testing period specified in this section.

(2) Torque the jam nut (drawing 9001336) on the neck cable (drawing ATD-6206) to 0.2 to 0.3 Nm (2-3 in-lbf).

(3) Mount the neck-headform assembly, defined in paragraph (b) of this section, on the pendulum so the midsagittal plane of the headform is vertical and coincides with the plane of motion of the pendulum as shown in Figure R3 for flexion and Figure R4 for extension tests.

(i) The moment and rotation data channels are defined to be zero when the longitudinal centerline of the neck and pendulum are parallel.

(ii) The test shall be conducted without inducing any torsion of the neck.

(4) Release the pendulum and allow it to fall freely to achieve an impact velocity of 5.2 ± 0.1 m/s (17.1 ± 0.3 ft/s) for flexion and 2.5 ± 0.1 m/s (8.2 ± 0.3 ft/s) for extension measured at the center of the pendulum accelerometer at the instant of contact with the honeycomb.

(i) Time-zero is defined as the time of initial contact between the pendulum striker plate and the honeycomb material. The pendulum data channel shall be defined to be zero at this time.

(ii) Stop the pendulum from the initial velocity with an acceleration vs. time pulse which meets the velocity change as specified in the following table. Integrate the pendulum acceleration data channel to obtain the velocity vs. time curve as indicated in Table B:

TABLE B—PENDULUM PULSE

Time m/s	Flexion		Time ms	Extension	
	m/s	ft/s		m/s	ft/s
10	1.6-2.3	5.2-7.5	6	0.8-1.2	2.6-3.9
20	3.4-4.2	11.2-13.8	10	1.5-2.1	4.9-6.9
25	4.3-5.2	14.1-17.1	14	2.2-2.9	7.2-9.5

§ 572.154

49 CFR Ch. V (10–1–10 Edition)

§ 572.154 Thorax assembly and test procedure.

(a) Thorax Assembly (refer to § 572.150(a)(1)(iv)). The thorax consists of the part of the torso assembly shown in drawing 921022-060.

(b) When the thorax of a completely assembled dummy (drawing 921022-000) is impacted by a test probe conforming to § 572.155(a) at 5.0 ± 0.1 m/s (16.5 ± 0.3 ft/s) according to the test procedure in paragraph (c) of this section, the peak force, measured by the impact probe in accordance with paragraph § 572.155(a), shall be not less than 1514 N (340.7 lbf) and not more than 1796 N (404.1 lbf).

(c) *Test procedure.* (1) Soak the dummy in a controlled environment at any temperature between 20.6 and 22.2 °C (69 and 72 °F) and at any relative humidity between 10 and 70 percent for at least four hours prior to a test. These temperature and humidity levels shall be maintained throughout the entire testing period specified in this section.

(2) The test dummy is clothed in a cotton-polyester based tight fitting sweat shirt with long sleeves and ankle long pants whose combined weight is not more than 0.25 kg (.55 lbs).

(3) Seat and orient the dummy on a level seating surface without back support as shown in Figure R5 of this subpart, with the lower limbs extended forward, parallel to the midsagittal plane and the arms 0 to 5 degrees forward of vertical. The dummy's midsagittal plane is vertical within ± 1 degree and the posterior surface of the upper spine box is aligned at 90 ± 1 degrees from the horizontal. (Shim material may be used under the upper legs to maintain the dummy's specified spine box surface alignment).

(4) Establish the impact point at the chest midsagittal plane so that the impact point of the longitudinal centerline of the probe coincides with the dummy's midsagittal plane, is centered on the torso 196 ± 2.5 mm (7.7 ± 0.1 in) vertically from the plane of the seating surface, and is within 0.5 degrees of a horizontal plane.

(5) Impact the thorax with the test probe so that at the moment of contact the probe's longitudinal center line falls within 2 degrees of a horizontal line in the dummy's midsagittal plane.

(6) Guide the test probe during impact so that there is no significant lateral, vertical or rotational movement.

(7) No suspension hardware, suspension cables, or any other attachments to the probe, including the velocity vane, shall make contact with the dummy during the test.

[65 FR 17188, Mar. 31, 2000, as amended at 66 FR 45784, Aug. 30, 2001]

§ 572.155 Test conditions and instrumentation.

(a) The test probe for thoracic impacts, except for attachments, shall be of rigid metallic construction and concentric about its longitudinal axis. Any attachments to the impactor, such as suspension hardware, impact vanes, etc., must meet the requirements of § 572.154(c)(7). The impactor shall have a mass of 2.86 ± 0.02 kg (6.3 ± 0.05 lbs) and a minimum mass moment of inertia of 164 kg-cm^2 ($0.145 \text{ lb-in-sec}^2$) in yaw and pitch about the CG of the probe. One-third of the weight of suspension cables and any attachments to the impact probe must be included in the calculation of mass, and such components may not exceed five percent of the total weight of the test probe. The impacting end of the probe, perpendicular to and concentric with the longitudinal axis of the probe, has a flat, continuous, and non-deformable 101.6 ± 0.25 mm (4.00 ± 0.01 in) diameter face with an edge radius of $7.6/12.7$ mm ($0.3/0.5$ in). The impactor shall have a 101–103 mm (4–4.1 in) diameter cylindrical surface extending for a minimum of 12.5 mm (0.5 in) to the rear from the impact face. The probe's end opposite to the impact face has provisions for mounting an accelerometer with its sensitive axis collinear with the longitudinal axis of the probe. The impact probe shall have a free air resonant frequency of not less than 1000 Hz measured in line with the longitudinal axis of the impactor, using the test method shown in the Procedures for Assembly, Disassembly and Inspection (PADI) document referenced in § 572.151.

(b) Head accelerometers shall have the dimensions, response characteristics, and sensitive mass locations specified in drawing SA572-S4 and be mounted in the head as shown in drawing 921022-000.

(c) The neck force-moment transducer shall have the dimensions, response characteristics, and sensitive axis locations specified in drawing SA572-S23 and shall be mounted for testing as shown in drawing 921022-000 and in figures R3 and R4 of this subpart.

(d) The shoulder force transducers shall have the dimensions and response characteristics specified in drawing SA572-S25 and are allowed to be mounted as optional instrumentation in place of part No. 921022-022 in the torso assembly as shown in drawing 921022-000.

(e) The thorax accelerometers shall have the dimensions, response characteristics, and sensitive mass locations specified in drawing SA572-S4 and be mounted in the torso assembly in triaxial configuration as shown in drawing 921022-000.

(f) The lumbar spine and lower neck force/moment transducer shall have the dimensions and response characteristics specified in drawing SA572-S23 and are allowed to be mounted as optional instrumentation in the torso assembly in place of part No. 910420-003 as shown in drawing 921022-000.

(g) The pelvis accelerometers shall have the dimensions, response characteristics, and sensitive mass locations specified in drawing SA572-S4 and are allowed to be mounted as optional instrumentation in the pelvis in triaxial configuration as shown in drawing 921022-000.

(h) The pubic force transducer shall have the dimensions and response characteristics specified in drawing SA572-S24 and is allowed to be mounted as optional instrumentation in place of part No. 921022-050 in the torso assembly as shown in drawing 921022-000.

(i) The outputs of acceleration and force-sensing devices installed in the dummy and in the test apparatus specified by this part are recorded in individual data channels that conform to the requirements of SAE Recommended Practice J211/1, Rev. Mar95

“Instrumentation for Impact Tests—Part 1—Electronic Instrumentation” (refer to §572.150(a)(3)), with channel classes as follows:

(1) Head and headform acceleration—Class 1000.

(2) Neck :

(i) Forces—Class 1000;

(ii) Moments—Class 600;

(iii) Pendulum acceleration—Class 180;

(iv) Rotation potentiometer response (if used)—CFC 60.

(3) Thorax:

(i) Spine and pendulum accelerations—Class 180;

(ii) Shoulder forces—Class 600;

(4) Lumbar:

(i) Forces—Class 1000;

(ii) Moments—Class 600;

(5) Pelvis:

(i) Accelerations—Class 1000;

(ii) Pubic—Class 1000.

(j) Coordinate signs for instrumentation polarity shall conform to SAE J1733, 1994-12, “Sign Convention For Vehicle Crash Testing, Surface Vehicle Information Report,” (refer to §572.150(a)(4)).

(k) The mountings for sensing devices shall have no resonance frequency within a range of 3 times the frequency range of the applicable channel class.

(l) Limb joints shall be set at 1 g, barely restraining the weight of the limb when it is extended horizontally. The force required to move a limb segment shall not exceed 2 g throughout the range of limb motion.

(m) Performance tests of the same component, segment, assembly, or fully assembled dummy shall be separated in time by period of not less than 30 minutes unless otherwise noted.

(n) Surfaces of dummy components may not be painted except as specified in this subpart or in drawings referenced in §572.150.

[65 FR 17188, Mar. 31, 2000, as amended at 66 FR 45784, Aug. 30, 2001]

Figure R 1
FRONTAL HEAD DROP TEST SET-UP SPECIFICATIONS

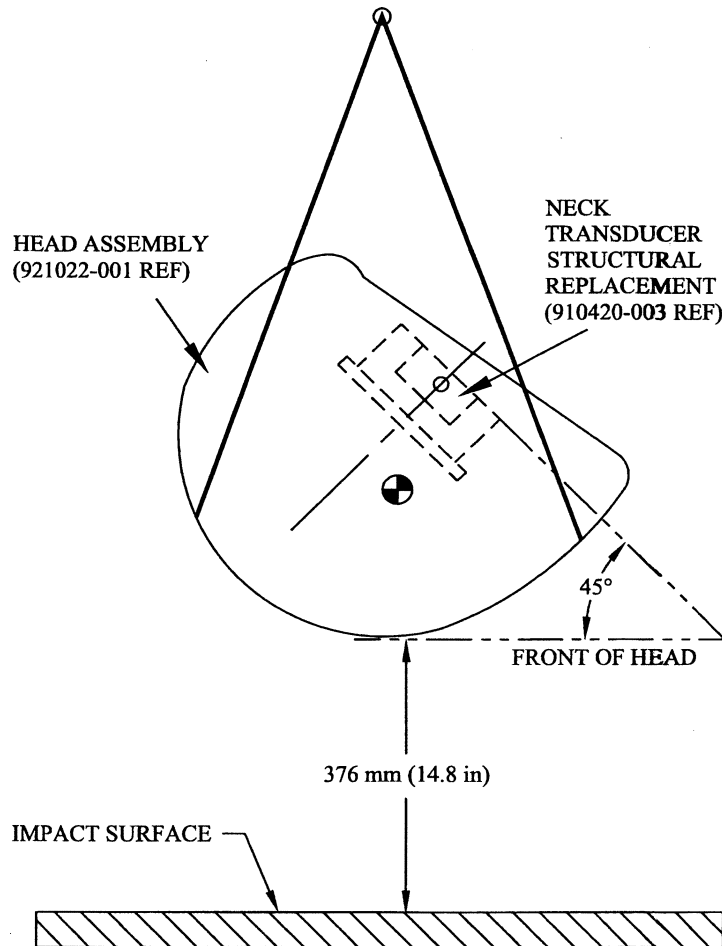


Figure R 2
REAR HEAD DROP TEST SET-UP SPECIFICATIONS

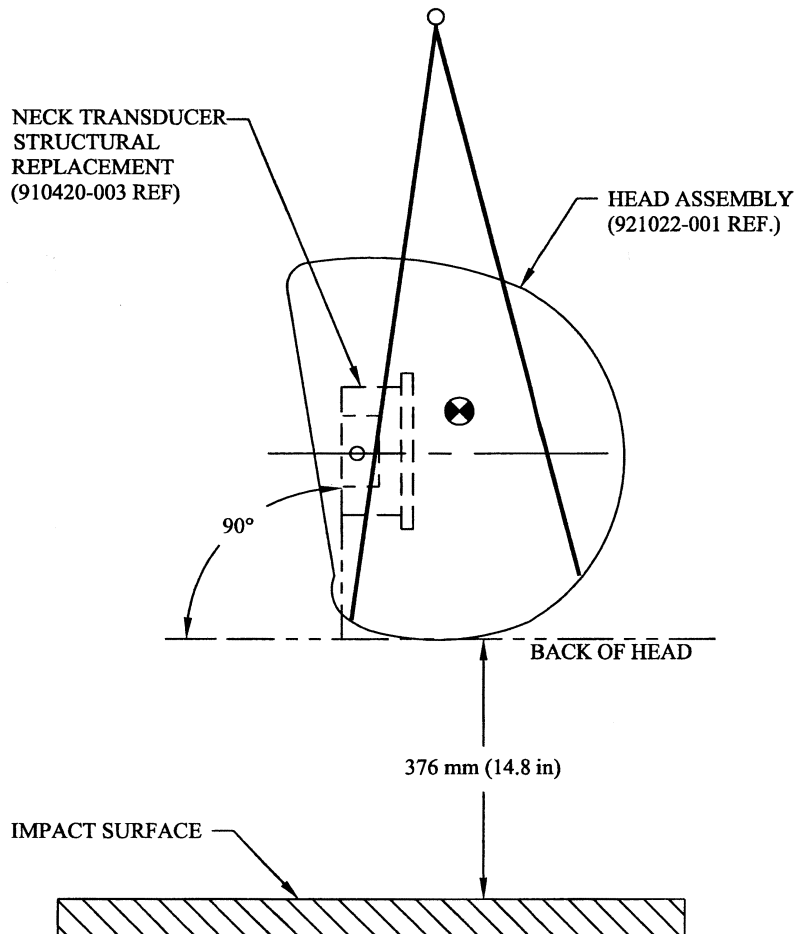
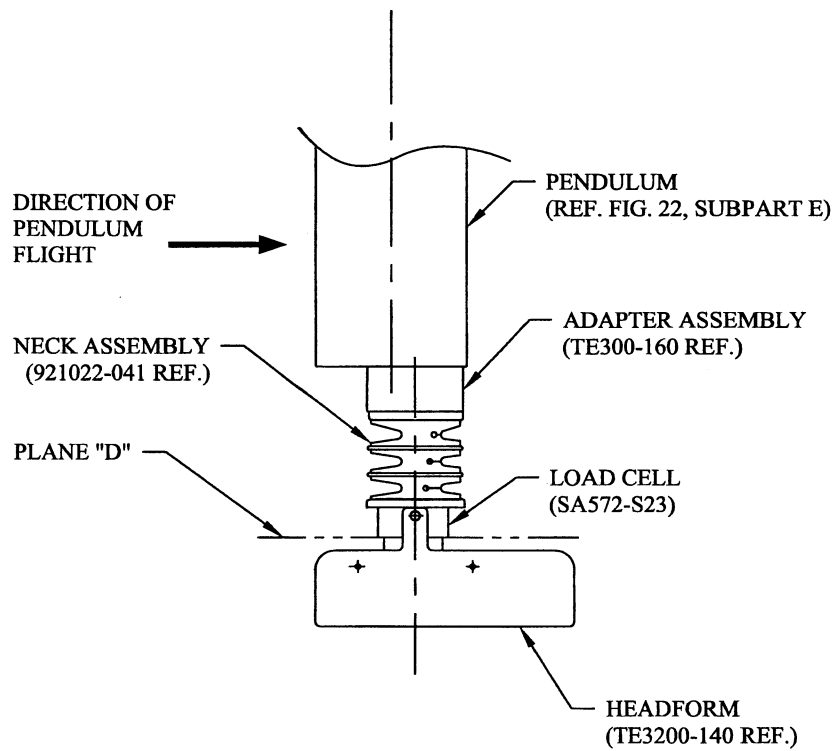
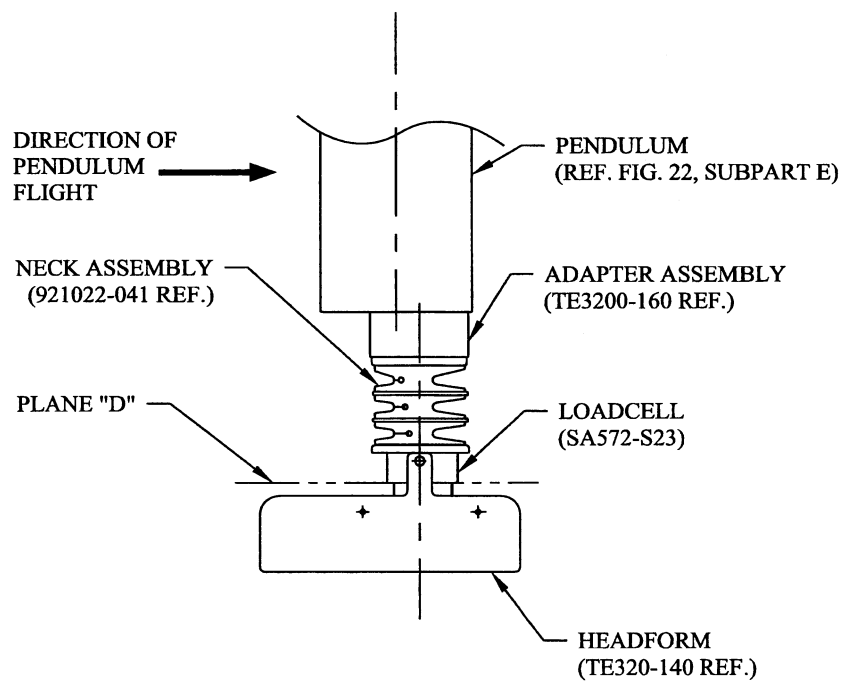


Figure R3
NECK FLEXION TEST SET-UP SPECIFICATIONS



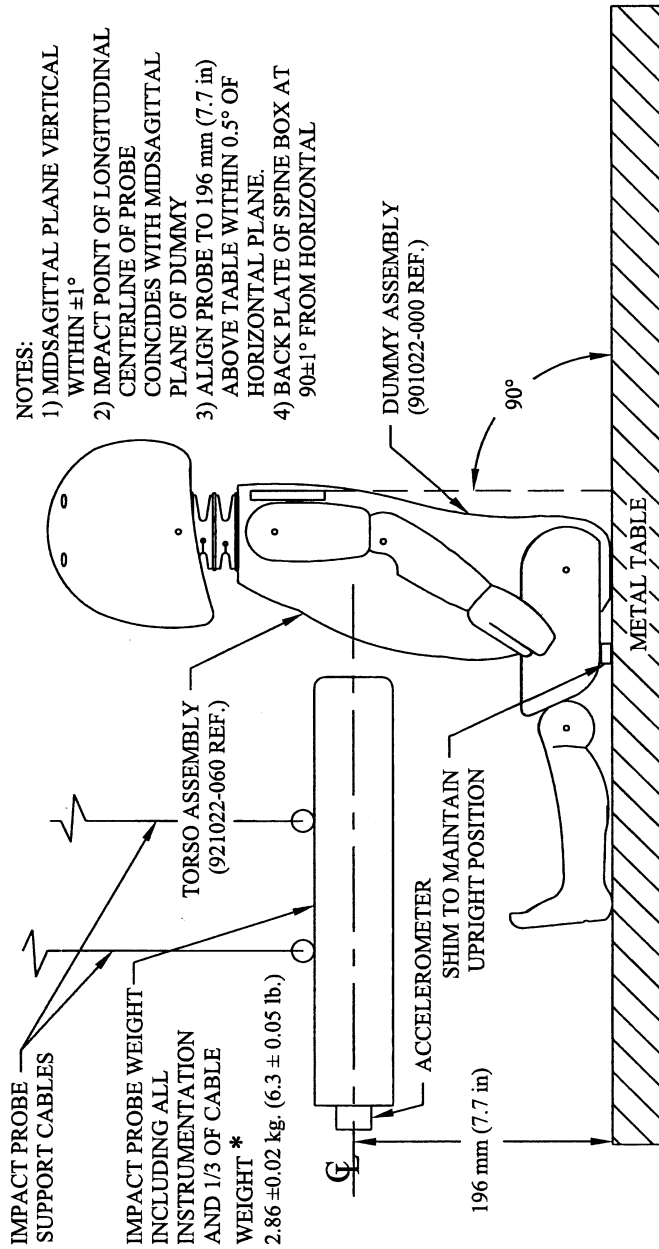
NOTE: MOUNT NECK AT LEADING EDGE OF PENDULUM TO
AVOID INTERFERENCE.

Figure R4
NECK EXTENSION TEST SET-UP SPECIFICATIONS



NOTE: MOUNT NECK AT LEADING EDGE OF PENDULUM TO
AVOID INTERFERENCE.

Figure R 5
THORAX IMPACT TEST SET-UP SPECIFICATIONS



- NOTES:
- 1) MIDSAGITTAL PLANE VERTICAL WITHIN ±1°
 - 2) IMPACT POINT OF LONGITUDINAL CENTERLINE OF PROBE COINCIDES WITH MIDSAGITTAL PLANE OF DUMMY
 - 3) ALIGN PROBE TO 196 mm (7.7 in) ABOVE TABLE WITHIN 0.5° OF HORIZONTAL PLANE.
 - 4) BACK PLATE OF SPINE BOX AT 90±1° FROM HORIZONTAL

* 1/3 OF CABLE WEIGHT NOT TO EXCEED 5% OF THE TOTAL IMPACT PROBE WEIGHT.

Subpart S—Hybrid III Six-Year-Old Weighted Child Test Dummy

SOURCE: 69 FR 42602, July 16, 2004, unless otherwise noted.

§ 572.160 Incorporation by reference.

(a) The following materials are hereby incorporated into this subpart S by reference:

(1) A drawings and specifications package entitled “Parts List and Drawings, Part 572 Subpart S, Hybrid III Weighted Six-Year Old Child Test Dummy (H-III6CW, Alpha Version) April 13, 2004”, incorporated by reference in § 572.161 and consisting of:

(i) Drawing No. 167-0000, Complete Assembly, incorporated by reference in § 572.161;

(ii) Drawing No. 167-2000, Upper Torso Assembly, incorporated by reference in §§ 572.161, 572.164, and 572.165 as part of a complete dummy assembly;

(iii) Drawing No. 167-2020 Revision A, dated December 8, 2005, Spine Box Weight, incorporated by reference in §§ 572.161 and 572.165 as part of a complete dummy assembly;

(iv) Drawing No. 167-3000, Lower Torso Assembly, incorporated by reference in §§ 572.161, and 572.165 as part of a complete dummy assembly;

(v) Drawing No. 167-3010 Revision A, dated December 8, 2005, Lumbar Weight Base, incorporated by reference in §§ 572.161 and 572.165 as part of a complete dummy assembly; and

(vi) The Hybrid III Weighted Six-Year-Old Child Parts/Drawing List, incorporated by reference in § 572.161.

(2) A procedures manual entitled “Procedures for Assembly, Disassembly, and Inspection (PADI) of the Hybrid III Six-Year-Old Weighted Child Test Dummy (H-III6CW), April 2004,” incorporated by reference in § 572.161;

(3) The Director of the Federal Register approved those materials incorporated by reference in accordance with 5 U.S.C. 552(a) and 1 CFR part 51. Copies of the materials may be inspected at NHTSA’s Technical Reference Library, 400 Seventh Street, SW., room 5109, Washington, DC, or at the National Archives and Records Administration (NARA). For information on the availability of this material at NARA, call 202-741-6030, or go to: http://www.archives.gov/federal_register/code_of_federal_regulations/ibr_locations.html.

www.archives.gov/federal_register/code_of_federal_regulations/ibr_locations.html.

(b) The incorporated materials are available as follows:

(1) The Drawings and Specifications for the Hybrid III Six-Year-Old Weighted Child Test Dummy referred to in paragraph (a)(1) of this section are available in electronic format through the NHTSA docket center and in paper format from Leet-Melbrook, Division of New RT, 18810 Woodfield Road, Gaithersburg, MD 20879, (301) 670-0090.

(2) [Reserved]

[69 FR 42602, July 16, 2004, as amended at 70 FR 77338, Dec. 30, 2005]

§ 572.161 General description.

(a) The Hybrid III Six-Year-Old Weighted Child Test Dummy is defined by drawings and specifications containing the following materials:

(1) “Parts List and Drawings, Part 572 Subpart S, Hybrid III Weighted Six-Year Old Child Test Dummy (H-III6CW, Alpha Version) April 13, 2004” (incorporated by reference, see § 572.160),

(2) The head, neck, arm, and leg assemblies specified in 49 CFR 572 subpart N; and

(3) “Procedures for Assembly, Disassembly, and Inspection (PADI) of the Hybrid III Six-Year-Old Weighted Child Test Dummy, April 2004” (incorporated by reference, see § 572.160).

TABLE A

Component assembly ¹	Drawing No.
Complete assembly	167-0000.
Upper torso assembly	167-2000.
Spine box weight	167-2020 Rev. A.
Lower torso assembly	167-3000.
Lumbar weight base	167-3010 Rev. A.

¹Head, neck, arm, and leg assemblies are as specified in 49 CFR 572 subpart N.

(b) Adjacent segments are joined in a manner such that except for contacts existing under static conditions, there is no contact between metallic elements throughout the range of motion or under simulated crash impact conditions.

(c) The structural properties of the dummy are such that the dummy must conform to Subpart S in every respect and Subpart N as applicable, before use

§ 572.162

in any test similar to those specified in Standard 208, "Occupant Crash Protection" (49 CFR 571.208), and Standard 213, "Child Restraint Systems" (49 CFR 571.213).

[69 FR 42602, July 16, 2004, as amended at 70 FR 77338, Dec. 30, 2005]

§ 572.162 Head assembly and test procedure.

The head assembly is assembled and tested as specified in 49 CFR 572.122 (Subpart N).

§ 572.163 Neck assembly and test procedure.

The neck assembly is assembled and tested as specified in 49 CFR 572.123 (Subpart N).

§ 572.164 Thorax assembly and test procedure.

(a) *Thorax (upper torso) assembly.* The thorax consists of the part of the torso assembly shown in drawing 167-2000 (incorporated by reference, see § 572.160).

(b) When the anterior surface of the thorax of a completely assembled dummy (drawing 167-2000) that is seated as shown in Figure S1 is impacted by a test probe conforming to 49 CFR 572.127(a) at 6.71 ± 0.12 m/s (22.0 ± 0.4 ft/s) according to the test procedure specified in 49 CFR 572.124(c):

(1) The maximum sternum displacement relative to the spine, measured with chest deflection transducer (specified in 49 CFR 572.124(b)(1)), must be not less than 38.0 mm (1.50 in) and not more than 46.0 mm (1.80 in). Within this specified compression corridor, the peak force, measured by the probe in accordance with 49 CFR 572.127, must be not less than 1205 N (270.9 lbf) and not more than 1435 N (322.6 lbf). The peak force after 12.5 mm (0.5 in) of sternum displacement, but before reaching the minimum required 38.0 mm (1.46 in) sternum displacement limit, must not exceed an upper limit of 1500 N.

(2) The internal hysteresis of the ribcage in each impact as determined by the plot of force vs. deflection in paragraph (b)(1) of this section must be not less than 65 percent but not more than 85 percent.

(c) *Test procedure.* The thorax assembly is tested as specified in 49 CFR 572.124(c).

49 CFR Ch. V (10-1-10 Edition)

§ 572.165 Upper and lower torso assemblies and torso flexion test procedure.

(a) *Upper/lower torso assembly.* The test objective is to determine the stiffness effects of the lumbar spine (specified in 49 CFR 572.125(a)), including cable (specified in 49 CFR 572.125(a)), mounting plate insert (specified in 49 CFR 572.125(a)), nylon shoulder bushing (specified in 49 CFR 572.125(a)), nut (specified in 49 CFR 572.125(a)), spine box weighting plates (drawing 167-2020 Revision A), lumbar base weight (drawing 167-3010 Revision A), and abdominal insert (specified in 49 CFR 572.125(a)), on resistance to articulation between the upper torso assembly (drawing 167-2000) and the lower torso assembly (drawing 167-3000). Drawing Nos. 167-2000, 167-2020 Revision A, 167-3000, and 167-3010 Revision A, are incorporated by reference, see § 572.160.

(b)(1) When the upper torso assembly of a seated dummy is subjected to a force continuously applied at the head to neck pivot pin level through a rigidly attached adaptor bracket as shown in Figure S2 according to the test procedure set out in 49 CFR 572.125(c), the lumbar spine-abdomen assembly must flex by an amount that permits the upper torso assembly to translate in angular motion until the machined surface of the instrument cavity at the back of the thoracic spine box is at 45 ± 0.5 degrees relative to the transverse plane, at which time the force applied as shown in Figure S2 must be within $88.6 \text{ N} \pm 25 \text{ N}$ ($20.0 \text{ lbf} \pm 5.6 \text{ lbf}$), and

(2) Upon removal of the force, the torso assembly must return to within 9 degrees of its initial position.

(c) *Test procedure.* The upper and lower torso assemblies are tested as specified in 49 CFR 572.125(c), except that in paragraph (c)(5) of that section, the initial torso orientation angle may not exceed 32 degrees.

[69 FR 42602, July 16, 2004, as amended at 70 FR 77338, Dec. 30, 2005]

§ 572.166 Knees and knee impact test procedure.

The knee assembly is assembled and tested as specified in 49 CFR 572.126 (Subpart N).

Nat'l Highway Traffic Safety Admin., DOT

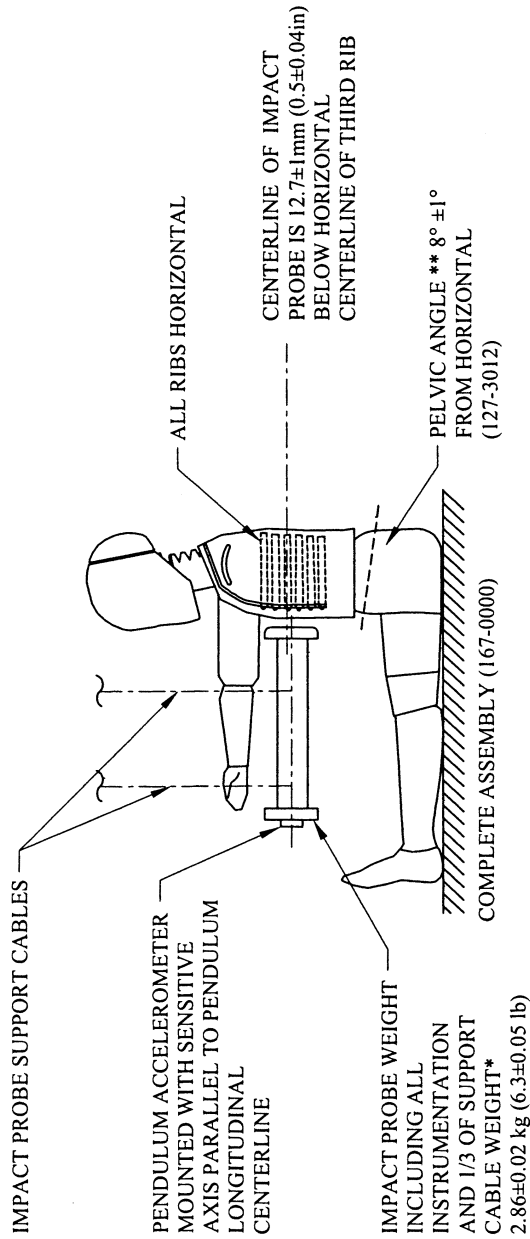
Pt. 572, Subpt. S, Figs.

§ 572.167 Test conditions and instrumentation.

The test conditions and instrumentation are as specified in 49 CFR 572.127 (Subpart N).

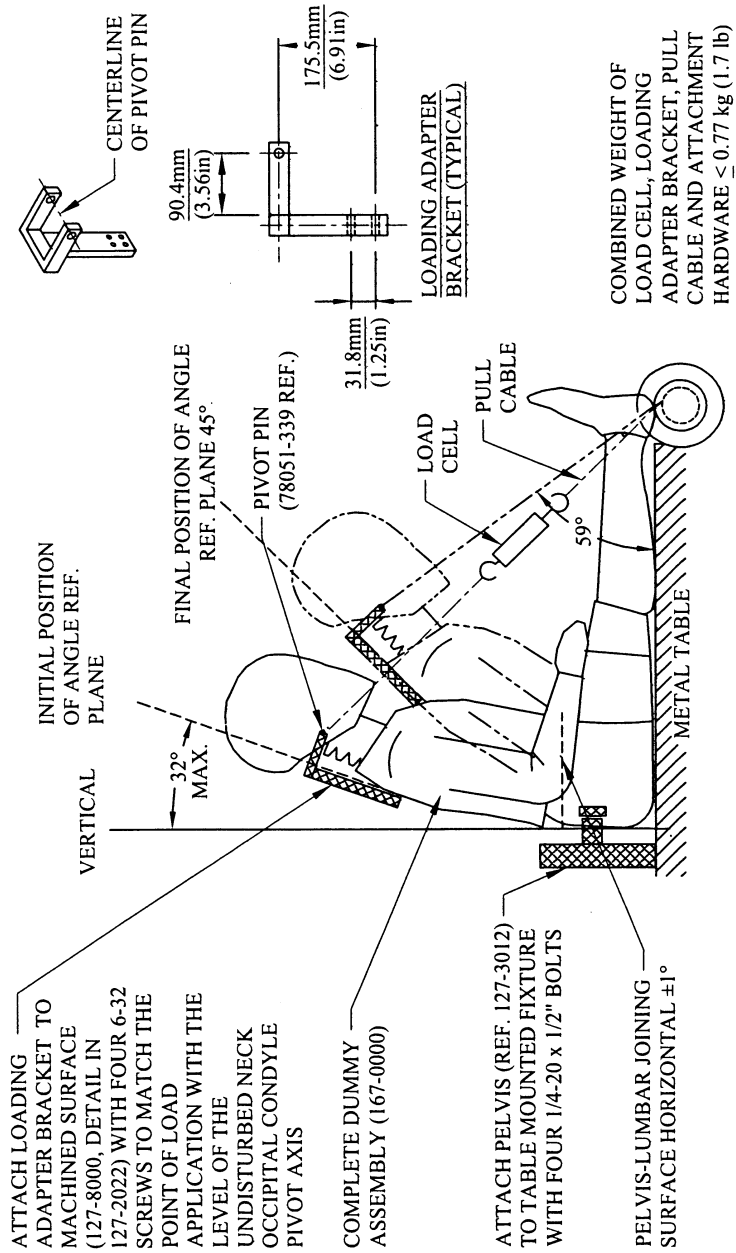
FIGURES TO SUBPART S OF PART 572

FIGURE S1
THORAX IMPACT TEST SET-UP SPECIFICATIONS



* 1/3 CABLE WEIGHT NOT TO EXCEED 5% OF THE TOTAL IMPACT PROBE WEIGHT
** PELVIS LUMBAR JOINING SURFACE

FIGURE S2
TORSO FLEXION TEST SET-UP SPECIFICATIONS



Subpart T [Reserved]

Subpart U, ES–2re Side Impact
Crash Test Dummy, 50th Per-
centile Adult Male

SOURCE: 71 FR 75331, Dec. 14, 2006, unless otherwise noted.

§ 572.180 Incorporated materials.

(a) The following materials are hereby incorporated into this Subpart by reference:

(1) A parts/drawing list entitled, “Parts/Drawings List, Part 572 Subpart U, Eurosid 2 with Rib Extensions (ES2re), February 2008,”

(2) A drawings and inspection package entitled “Parts List and Drawings, Part 572 Subpart U, Eurosid 2 with Rib Extensions (ES–2re, Alpha Version), February 2008,” consisting of:

(i) Drawing No. 175–0000 ES–2re Dummy Assembly;

(ii) Drawing No. 175–1000 Head Assembly;

(iii) Drawing No. 175–2000, Neck Assembly Test/Cert;

(iv) Drawing No. 175–3000, Shoulder Assembly;

(v) Drawing No. 175–3500, Arm Assembly, Left;

(vi) Drawing No. 175–3800, Arm Assembly, Right;

(vii) Drawing No. 175–4000, Thorax Assembly with Rib Extensions;

(viii) Drawing No. 175–5000, Abdominal Assembly;

(ix) Drawing No. 175–5500 Lumbar Spine Assembly;

(x) Drawing No. 175–6000 Pelvis Assembly;

(xi) Drawing No. 175–7000–1, Leg Assembly—left;

(xii) Drawing No. 175–7000–2, Leg Assembly—right;

(xiii) Drawing No. 175–8000, Neoprene Body Suit; and,

(xiv) Drawing No. 175–9000, Headform Assembly;

(3) A procedures manual entitled “Procedures for Assembly, Disassembly and Inspection (PADI) of the EuroSID–2re 50th Percentile Adult Male Side Impact Crash Test Dummy, February 2008,” incorporated by reference in §§ 572.180(a)(2), and 572.181(a);

(4) Society of Automotive Engineers (SAE) Recommended Practice J211, Rev. Mar 95 “Instrumentation for Impact Tests—Part 1—Electronic Instrumentation”; and,

(5) SAE J1733 of 1994–12 “Sign Convention for Vehicle Crash Testing.”

(b) The Director of the Federal Register approved the materials incorporated by reference in accordance with 5 U.S.C. 552(a) and 1 CFR part 51. Copies of the materials may be inspected at the Department of Transportation, Docket Operations, Room W12–140, 1200 New Jersey Avenue, SE., Washington, DC 20590, telephone (202) 366–9826, and at the National Archives and Records Administration (NARA), and in electronic format through *Regulations.gov*. For information on the availability and inspection of this material at NARA, call 202–741–6030, or go to:

http://www.archives.gov/federal_register/code_of_federal_regulations/ibr_locations.html. For information on the availability and inspection of this material at *Regulations.gov*, call 1–877–378–5457, or go to: <http://www.regulations.gov>.

(c) The incorporated materials are available as follows:

(1) The Parts/Drawings List, Part 572 Subpart U, Eurosid 2 with Rib Extensions (ES2re), February 2008, referred to in paragraph (a)(1) of this section, the Parts List and Drawings, Part 572 Subpart U, Eurosid 2 with Rib Extensions (ES–2re, Alpha Version), February 2008, referred to in paragraph (a)(2) of this section, and the PADI document referred to in paragraph (a)(3) of this section, are available in electronic format through *Regulations.gov* and in paper format from Leet-Melbrook, Division of New RT, 18810 Woodfield Road, Gaithersburg, MD 20879, telephone (301) 670–0090.

(2) The SAE materials referred to in paragraphs (a)(4) and (a)(5) of this section are available from the Society of Automotive Engineers, Inc., 400 Commonwealth Drive, Warrendale, PA 15096, telephone 1–877–606–7323.

[71 FR 75331, Dec. 14, 2006, as amended at 73 FR 33920, June 16, 2008]

§ 572.181 General description.

(a) The ES-2re Side Impact Crash Test Dummy, 50th Percentile Adult Male, is defined by:

(1) The drawings and specifications contained in the "Parts List and Drawings, Part 572 Subpart U, Eurosid 2 with Rib Extensions (ES-2re, Alpha Version), February 2008," incorporated by reference in §572.180, which includes the technical drawings and specifications described in Drawing 175-0000, the titles of which are listed in Table A;

TABLE A

Component assembly	Drawing number
Head Assembly	175-1000
Neck Assembly Test/Cert	175-2000
Neck Bracket Including Lifting Eyebolt	175-2500
Shoulder Assembly	175-3000
Arm Assembly-Left	175-3500
Arm Assembly-Right	175-3800
Thorax Assembly with Rib Extensions	175-4000
Abdominal Assembly	175-5000
Lumbar Spine Assembly	175-5500
Pelvis Assembly	175-6000
Leg Assembly, Left	175-7000-1
Leg Assembly, Right	175-7000-2
Neoprene Body Suit	175-8000

(2) "Parts/Drawings List, Part 572 Subpart U, Eurosid 2 with Rib Extensions (ES2re), February 2008," containing 8 pages, incorporated by reference in §572.180,

(3) A listing of available transducers-crash test sensors for the ES-2re Crash Test Dummy is shown in drawing 175-0000 sheet 4 of 6, dated February 2008, incorporated by reference in §572.180,

(4) Procedures for Assembly, Disassembly and Inspection (PADI) of the ES-2re Side Impact Crash Test Dummy, February 2008, incorporated by reference in §572.180,

(5) Sign convention for signal outputs reference document SAE J1733 Information Report, titled "Sign Convention for Vehicle Crash Testing" dated December 1994, incorporated by reference in §572.180.

(b) Exterior dimensions of ES-2re test dummy are shown in drawing 175-0000 sheet 3 of 6, dated February 2008.

(c) Weights of body segments (head, neck, upper and lower torso, arms and upper and lower segments) and the center of gravity location of the head are shown in drawing 175-0000 sheet 2 of 6, dated February 2008.

(d) Adjacent segments are joined in a manner such that, except for contacts existing under static conditions, there is no additional contact between metallic elements of adjacent body segments throughout the range of motion.

(e) The structural properties of the dummy are such that the dummy conforms to this Subpart in every respect before use in any test similar to those in Standard No. 214, Side Impact Protection and Standard No. 201, Occupant Protection in Interior Impact.

[71 FR 75331, Dec. 14, 2006, as amended at 73 FR 33921, June 16, 2008]

§ 572.182 Head assembly.

(a) The head assembly consists of the head (drawing 175-1000), including the neck upper transducer structural replacement, and a set of three (3) accelerometers in conformance with specifications in §572.189(b) and mounted as shown in drawing (175-0000 sheet 1 of 6). When tested to the test procedure specified in paragraph (b) of this section, the head assembly shall meet performance requirements specified in paragraph (c) of this section.

(b) *Test procedure.* The head shall be tested per procedure specified in 49 CFR §572.112(a).

(c) *Performance criteria.* (1) When the head assembly is dropped in accordance with §572.112 (a), the measured peak resultant acceleration shall be between 125 g's and 155 g's;

(2) The resultant acceleration-time curve shall be unimodal to the extent that oscillations occurring after the main acceleration pulse shall not exceed 15% (zero to peak) of the main pulse;

(3) The fore-and-aft component of the head acceleration shall not exceed 15 g's.

§ 572.183 Neck assembly.

(a) The neck assembly consists of parts shown in drawing 175-2000. For purposes of this test, the neck is mounted within the headform assembly 175-9000 as shown in Figure U1 in appendix A to this subpart. When subjected to tests procedures specified in paragraph (b) of this section, the neck-headform assembly shall meet performance requirements specified in paragraph (c) of this section.

§ 572.184

49 CFR Ch. V (10–1–10 Edition)

(b) *Test procedure.* (1) Soak the neck-headform assembly in a test environment as specified in § 572.189(n);

(2) Attach the neck-headform assembly to the Part 572 subpart E pendulum test fixture as shown in Figure U2-A in appendix A to this subpart, so that the midsagittal plane of the neck-headform assembly is vertical and perpendicular to the plane of motion of the pendulum longitudinal centerline shown in Figure U2-A. Torque the half-spherical screws (175-2004) located at either end of the neck assembly to 88 ±5 in-lbs using the neck compression tool (175-9500) or equivalent;

(3) Release the pendulum from a height sufficient to allow it to fall freely to achieve an impact velocity of 3.4±0.1 m/s measured at the center of the pendulum accelerometer (Figure 22 as set forth in 49 CFR 572.33) at the time the pendulum makes contact with the decelerating mechanism. The velocity-time history of the pendulum falls inside the corridor determined by the upper and lower boundaries specified in Table 1 to paragraph (a) of this section.

(4) Allow the neck to flex without the neck-headform assembly making contact with any object;

(5) Time zero is defined in § 572.189(j).

TABLE 1 TO PARAGRAPH (A)—ES-2RE NECK CERTIFICATION PENDULUM VELOCITY CORRIDOR

Upper boundary		Lower boundary	
Time (ms)	Velocity (m/s)	Time (ms)	Velocity (m/s)
1.0	0.00	0.0	-0.05
3.0	-0.25	2.5	-0.375
14.0	-3.20	13.5	-3.7
		17.0	-3.7

(c) *Performance criteria.* (1) The pendulum deceleration pulse is to be characterized in terms of decrease in velocity as determined by integrating the filtered pendulum acceleration response from time-zero.

(2) The maximum rotation in the lateral direction of the reference plane of the headform (175-9000) as shown in Figure U2-B in appendix A to this subpart, shall be 49 to 59 degrees with respect to the longitudinal axis of the pendulum occurring between 54 and 66 ms from time zero. Rotation of the headform-neck assembly and the neck

angle with respect to the pendulum shall be measured with potentiometers specified in § 572.189(c), installed as shown in drawing 175-9000, and calculated per procedure specified in Figure U2-B in appendix A to this subpart;

(3) The decaying headform rotation vs. time curve shall cross the zero angle with respect to its initial position at time of impact relative to the pendulum centerline between 53 ms to 88 ms after the time the peak translation-rotation value is reached.

[71 FR 75331, Dec. 14, 2006, as amended at 73 FR 33921, June 16, 2008]

§ 572.184 **Shoulder assembly.**

(a) The shoulder (175-3000) is part of the body assembly shown in drawing 175-0000. When subjected to impact tests specified in paragraph (b) of this section, the shoulder assembly shall meet performance requirements of paragraph (c) of this section.

(b) *Test procedure.* (1) Soak the dummy assembly, without suit and shoulder foam pad (175-3010), in a test environment as specified in § 572.189(n);

(2) The dummy is seated, as shown in Figure U3 in appendix A to this subpart, on a flat, horizontal, rigid surface covered by two overlaid 2 mm thick Teflon sheets and with no back support of the dummy's torso. The dummy's torso spine backplate is vertical within ±2 degrees and the midsagittal plane of the thorax is positioned perpendicular to the direction of the plane of motion of the impactor at contact with the shoulder. The arms are oriented forward at 50±2 degrees from the horizontal, pointing downward. The dummy's legs are horizontal and symmetrical about the midsagittal plane with the distance between the innermost point on the opposite ankle at 100 ±5 mm. The length of the elastic shoulder cord (175-3015) shall be adjusted so that a force between and including 27.5 and 32.5 N applied in a forward direction at 4 ±1 mm from the outer edge of the clavicle in the same plane as the clavicle movement, is required to initiate a forward motion of 1 to 5 mm;

(3) The impactor is the same as defined in § 572.189(a);

(4) The impactor is guided, if needed, so that at contact with the shoulder,

its longitudinal axis is within ± 0.5 degrees of a horizontal plane and perpendicular (± 0.5 degrees) to the midsagittal plane of the dummy and the centerpoint on the impactor's face is within 5 mm of the center of the upper arm pivot bolt (5000040) at contact with the test dummy, as shown in Figure U3 in appendix A to this subpart;

(5) The impactor impacts the dummy's shoulder at 4.3 ± 0.1 m/s.

(c) *Performance criteria.* The peak acceleration of the impactor is between 7.5 g's and 10.5 g's during the pendulum's contact with the dummy.

§ 572.185 Thorax (upper torso) assembly.

(a) The thorax assembly of the dummy must meet the requirements of both (b) and (c) of this section. Section 572.185(b) specifies requirements for an individual rib drop test, and § 572.185(c) specifies requirements for a full-body thorax impact test.

(b) *Individual rib drop test.* For purposes of this test, the rib modules (175-4002), which are part of the thorax assembly (175-4000), are tested as individual units. When subjected to test procedures specified in paragraph (b)(1) of this section, the rib modules shall meet performance requirements specified in paragraph (b)(2) of this section. Each rib is tested at both the 459 mm and 815 mm drop height tests described in paragraphs (b)(1)(v)(A) and (B) of this section.

(1) *Test procedure.* (i) Soak the rib modules (175-4002) in a test environment as specified in 572.189(n);

(ii) Mount the rib module rigidly in a drop test fixture as shown in Figure U7 in appendix A to this subpart with the impacted side of the rib facing up;

(iii) The drop test fixture contains a free fall guided mass of 7.78 ± 0.01 kg that is of rigid construction and with a flat impact face 150 ± 1.0 mm in diameter and an edge radius of ± 0.25 mm;

(iv) Align the vertical longitudinal centerline of the drop mass so that the centerpoint of the downward-facing flat surface is aligned to impact the centerline of the rib rail guide system within ± 2.5 mm.

(v) The impacting mass is dropped from the following heights:

(A) 459 ± 5 mm

(B) 815 ± 8 mm

(vi) A test cycle consists of one drop from each drop height specified in paragraph (b)(1)(v) of this section. Allow a period of not less than five (5) minutes between impacts in a single test cycle. Allow a period of not less than thirty (30) minutes between two separate cycles of the same rib module.

(2) *Performance criteria.*

(i) Each of the rib modules shall deflect as specified in paragraphs (b)(2)(i)(A) and (B) of this section, with the deflection measurements made with the internal rib module position transducer specified in § 572.189(d):

(A) Not less than 36 mm and not more than 40 mm when impacted by the mass dropped from 459 mm; and,

(B) Not less than 46 mm and not more than 51 mm when impacted by the mass dropped from 815 mm.

(c) *Full-body thorax impact test.* The thorax is part of the upper torso assembly shown in drawing 175-4000. For this full-body thorax impact test, the dummy is tested as a complete assembly (drawing 175-0000) with the struck-side arm (175-3500, left arm; 175-3800, right arm) removed. The dummy's thorax is equipped with deflection potentiometers as specified in drawing SA572-S69. When subjected to the test procedures specified in paragraph (c)(1) of this section, the thorax shall meet the performance requirements set forth in paragraph (c)(2).

(1) *Test Procedure.* (i) Soak the dummy assembly (175-0000), with struck-side arm (175-3500, left arm; 175-3800, right arm), shoulder foam pad (175-3010), and neoprene body suit (175-8000) removed, in a test environment as specified in § 572.189(n);

(ii) The dummy is seated, as shown in Figure U4 in appendix A to this subpart, on a flat, horizontal, rigid surface covered by two overlaid 2 mm thick Teflon sheets and with no back support of the dummy's torso. The dummy's torso spine backplate is vertical within ± 2 degrees and the midsagittal plane of thorax is positioned perpendicular to the direction of the plane of motion of the impactor at contact with the thorax. The non-struck side arm is oriented vertically, pointing downward. The dummy's legs are horizontal and symmetrical about the midsagittal

§572.186

plane with the distance between the innermost point on the opposite ankle at 100 ± 5 mm;

(iii) The impactor is the same as defined in §572.189(a);

(iv) The impactor is guided, if needed, so that at contact with the thorax its longitudinal axis is within ± 0.5 degrees of horizontal and perpendicular ± 0.5 degrees to the midsagittal plane of the dummy and the centerpoint of the impactor's face is within 5 mm of the impact point on the dummy's middle rib shown in Figure U4 in appendix A to this subpart;

(v) The impactor impacts the dummy's thorax at $5.5 \text{ m/s} \pm 0.1 \text{ m/s}$.

(vi) Time zero is defined in §572.189(k).

(2) *Performance Criteria.* (i) The individual rib modules shall conform to the following range of deflections:

(A) Upper rib not less than 34 mm and not greater than 41 mm;

(B) Middle rib not less than 37 mm and not greater than 45 mm;

(C) Lower rib not less than 37 mm and not greater than 44 mm.

(ii) The impactor force shall be computed as the product of the impact probe acceleration and its mass. The peak impactor force at any time after 6 ms from time zero shall be not less than 5100 N and not greater than 6200 N.

[71 FR 75331, Dec. 14, 2006, as amended at 73 FR 33921, June 16, 2008]

§572.186 Abdomen assembly.

(a) The abdomen assembly (175-5000) is part of the dummy assembly shown in drawing 175-0000 including load sensors specified in §572.189(e). When subjected to tests procedures specified in paragraph (b) of this section, the abdomen assembly shall meet performance requirements specified in paragraph (c) of this section.

(b) *Test procedure.*

(1) Soak the dummy assembly (175-0000), without suit (175-8000) and shoulder foam pad (175-3010), as specified in §572.189(n);

(2) The dummy is seated as shown in Figure U5 in appendix A to this subpart;

(3) The abdomen impactor is the same as specified in §572.189(a) except that on its rectangular impact surface

49 CFR Ch. V (10-1-10 Edition)

is affixed a special purpose block whose weight is 1.0 ± 0.01 kg. The block is 70 mm high, 150 mm wide and 60 to 80 mm deep. The impact surface is flat, has a minimum Rockwell hardness of M85, and an edge radius of 4 to 5 mm. The block's wide surface is horizontally oriented and centered on the longitudinal axis of the probe's impact face as shown in Figure U5-A in appendix A to this subpart;

(4) The impactor is guided, if needed, so that at contact with the abdomen its longitudinal axis is within ± 0.5 degrees of a horizontal plane and perpendicular ± 0.5 degrees to the midsagittal plane of the dummy and the centerpoint on the impactor's face is aligned within 5 mm of the center point of the middle load measuring sensor in the abdomen as shown in Figure U5;

(5) The impactor impacts the dummy's abdomen at $4.0 \text{ m/s} \pm 0.1 \text{ m/s}$;

(6) Time zero is defined in §572.189(k).

(c) *Performance criteria.*

(1) The maximum sum of the forces of the three abdominal load sensors, specified in 572.189(e), shall be not less than 2200 N and not more than 2700 N and shall occur between 10 ms and 12.3 ms from time zero. The calculated sum of the three load cell forces must be concurrent in time.

(2) Maximum impactor force (impact probe acceleration multiplied by its mass) is not less than 4000 N and not more than 4800 N occurring between 10.6 ms and 13.0 ms from time zero.

§572.187 Lumbar spine.

(a) The lumbar spine assembly consists of parts shown in drawing 175-5500. For purposes of this test, the lumbar spine is mounted within the headform assembly 175-9000 as shown in Figure U1 in appendix A to this subpart. When subjected to tests procedures specified in paragraph (b) of this section, the lumbar spine-headform assembly shall meet performance requirements specified in paragraph (c) of this section.

(b) *Test procedure.* (1) Soak the lumbar spine-headform assembly in a test environment as specified in §572.189(n);

(2) Attach the lumbar spine-headform assembly to the Part 572 pendulum test fixture per procedure in §572.183(b)(2)

and as shown in Figure U2-A in appendix A to this subpart. Torque the lumbar hex nut (p/n 9000057) on to the lumbar cable assembly (175-5506) to 50 ± 5 in-lb;

(3) Release the pendulum from a height sufficient to allow it to fall freely to achieve an impact velocity of 6.05 ± 0.1 m/s measured at the center of the pendulum accelerometer (Figure 22) at the time the pendulum makes contact with its decelerating mechanism. The velocity-time history of the pendulum falls inside the corridor determined by the upper and lower boundaries specified in Table 1 to paragraph (b) of this section;

(4) Allow the lumbar spine to flex without the lumbar spine or the headform making contact with any object;

(5) Time zero is defined in § 572.189(j).

TABLE 1 TO PARAGRAPH (b)—ES-2RE LUMBAR SPINE CERTIFICATION PENDULUM VELOCITY CORRIDOR

Upper boundary		Lower boundary	
Time (ms)	Velocity (m/s)	Time (ms)	Velocity (m/s)
1.0	0.00	0.0	-0.05
3.7	-0.24	2.7	-0.425
27.0	-5.80	24.5	-6.50
		30.0	-6.50

(c) *Performance criteria.* (1) The pendulum deceleration pulse is to be characterized in terms of decrease in velocity as determined by integrating the filtered pendulum acceleration response from time-zero.

(2) The maximum rotation in the lateral direction of the reference plane of the headform (175-9000) as shown in Figure U2-B in appendix A to this subpart, shall be 45 to 55 degrees with respect to the longitudinal axis of the pendulum occurring between 39 and 53 ms from time zero. Rotation of the headform-neck assembly shall be measured with potentiometers specified in § 572.189(c), installed as shown in drawing 175-9000, and calculated per procedure specified in Figure U2-B in appendix A to this subpart.

(3) The decaying headform rotation vs. time curve shall cross the zero angle with respect to its initial position at impact relative to the pendulum centerline between 37 ms to 57

ms after the time the peak translation-rotation value is reached.

[71 FR 75331, Dec. 14, 2006, as amended at 73 FR 33921, June 16, 2008]

§ 572.188 Pelvis.

(a) The pelvis (175-6000) is part of the torso assembly shown in drawing 175-0000. The pelvis is equipped with a pubic symphysis load sensor in conformance with § 572.189(f) and mounted as shown in drawing (175-0000 sheet 4). When subjected to tests procedures specified in paragraph (b) of this section, the pelvis assembly shall meet performance requirements specified in paragraph (c) of this section.

(b) *Test procedure.*

(1) Soak the dummy assembly (175-0000) without suit (175-8000) and shoulder foam pad (175-3010) as specified in § 572.189(n);

(2) The dummy is seated as specified in Figure U6 in appendix A to this subpart;

(3) The pelvis impactor is the same as specified in § 572.189(a);

(4) The impactor is guided, if needed, so that at contact with the pelvis its longitudinal axis is within ± 0.5 degrees of a horizontal plane and perpendicular to the midsagittal plane of the dummy and the centerpoint on the impactor's face is within 5 mm of the center of the H-point in the pelvis, as shown in Figure U6 in appendix A to this subpart;

(5) The impactor impacts the dummy's pelvis at 4.3 ± 0.1 m/s.

(6) Time zero is defined in § 572.189(k).

(c) *Performance criteria.* (1) The impactor force (probe acceleration multiplied by its mass) shall be not less than 4,700 N and not more than 5,400 N, occurring between 11.8 ms and 16.1 ms from time zero;

(2) The pubic symphysis load, measured with load cell specified in § 572.189(f) shall be not less than 1,230 N and not more than 1,590 N occurring between 12.2 ms and 17.0 ms from time zero.

[71 FR 75331, Dec. 14, 2006, as amended at 73 FR 33921, June 16, 2008]

§ 572.189 Instrumentation and test conditions.

(a) The test probe for lateral shoulder, thorax without arm, abdomen, and pelvis impact tests is the same as that

specified in §572.36(a) and the impact probe has a minimum mass moment of inertia in yaw of 9,000 kg-cm², a free air resonant frequency not less than 1,000 Hz and the probe's end opposite to the impact face has provisions to mount an accelerometer with its sensitive axis collinear with the longitudinal axis of the probe. All hardware attached directly to the impactor and one-third (1/3) of the mass of the suspension cables must be included in the calculations of the total impactor mass. The sum mass of the attachments and 1/3 cable mass must not exceed 5 percent of the total pendulum mass. No suspension hardware, suspension cables, or any other attachments to the test probe, including velocity vane, shall make contact with the dummy during the test.

(b) Accelerometers for the head, the thoracic spine, and the pelvis conform to specifications of SA572-S4.

(c) Rotary potentiometer for the neck and lumbar spine certification tests conforms to SA572-53.

(d) Linear position transducer for the thoracic rib conforms to SA572-S69.

(e) Load sensors for the abdomen conform to specifications of SA572-S75.

(f) Load sensor for the pubic symphysis conforms to specifications of SA572-77.

(g) Load sensor for the lumbar spine conforms to specifications of SA572-76.

(h) Instrumentation and sensors conform to the Recommended Practice SAE J-211 (Mar. 1995)—Instrumentation for Impact Test unless noted otherwise.

(i) All instrumented response signal measurements shall be treated to the following specifications:

(1) Head acceleration—Digitally filtered CFC 1000;

(2) Neck and lumbar spine rotations—Digitally filtered CFC 180;

(3) Neck and lumbar spine pendulum accelerations—Digitally filtered CFC 60;

(4) Pelvis, shoulder, thorax without arm, and abdomen impactor accelerations—Digitally filtered CFC 180;

(5) Abdominal and pubic symphysis force—Digitally filtered at CFC 600;

(6) Thorax deflection—Digitally filtered CFC 180.

(j)(1) Filter the pendulum acceleration data using a SAE J211 CFC 60 filter.

(2) Determine the time when the filtered pendulum accelerometer data first crosses the -10 g level (T_{10}).

(3) Calculate time-zero: $T_0 = T_{10} - T_m$.

Where:

$T_m = 1.417$ ms for the Neck Test
 $= 1.588$ ms for the Lumbar Spine Test

(4) Set the data time-zero to the sample number nearest to the calculated T_0 .

(k)(1) Filter the pendulum acceleration data using a SAE J211 CFC 180 filter.

(2) Determine the time when the filtered pendulum accelerometer data first crosses the -1.0 m/s² (-.102 g) acceleration level (T_0).

(3) Set the data time-zero to the sample number of the new T_0 .

(l) Mountings for the head, spine and pelvis accelerometers shall have no resonance frequency within a range of 3 times the frequency range of the applicable channel class.

(m) Limb joints of the test dummy are set at the force between 1 to 2 G's, which just supports the limb's weight when the limbs are extended horizontally forward. The force required to move a limb segment does not exceed 2 G's throughout the range of the limb motion.

(n) Performance tests are conducted, unless specified otherwise, at any temperature from 20.6 to 22.2 degrees C. (69 to 72 degrees F.) and at any relative humidity from 10 percent to 70 percent after exposure of the dummy to those conditions for a period of not less than 4 hours.

(o) Certification tests of the same component, segment, assembly, or fully assembled dummy shall be separated in time by a period of not less than thirty (30) minutes unless otherwise specified.

APPENDIX A TO SUBPART U OF PART 572—FIGURES

Figure U1

NECK/LUMBAR SPINE ATTACHED TO HEADFORM

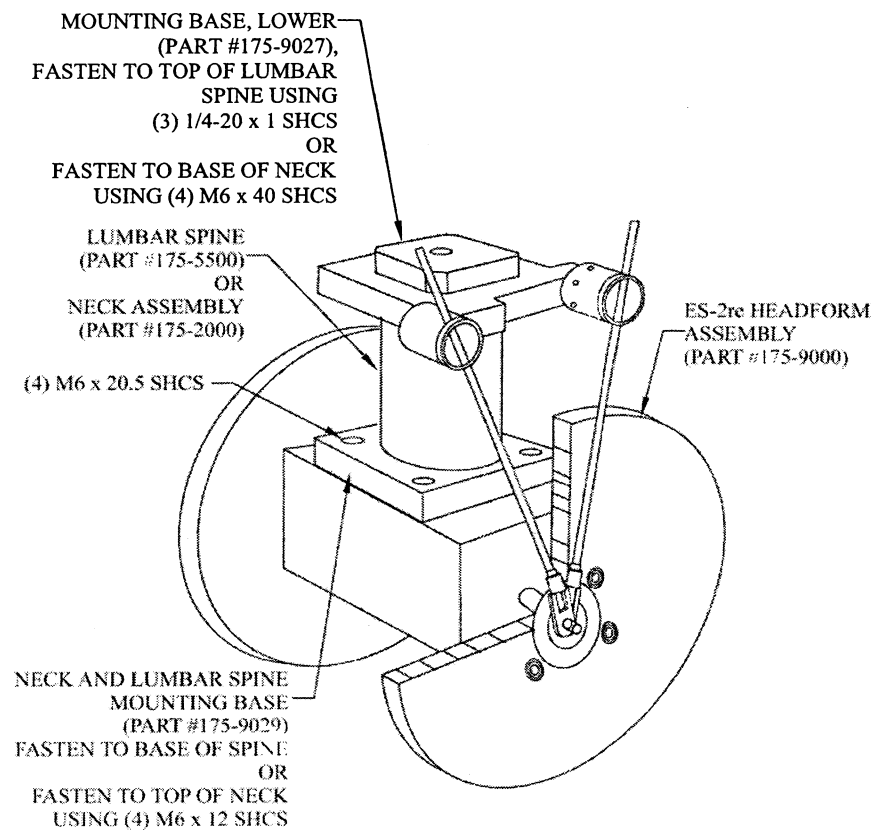


Figure U2-A
NECK/LUMBAR SPINE/HEADFORM ATTACHED TO PENDULUM

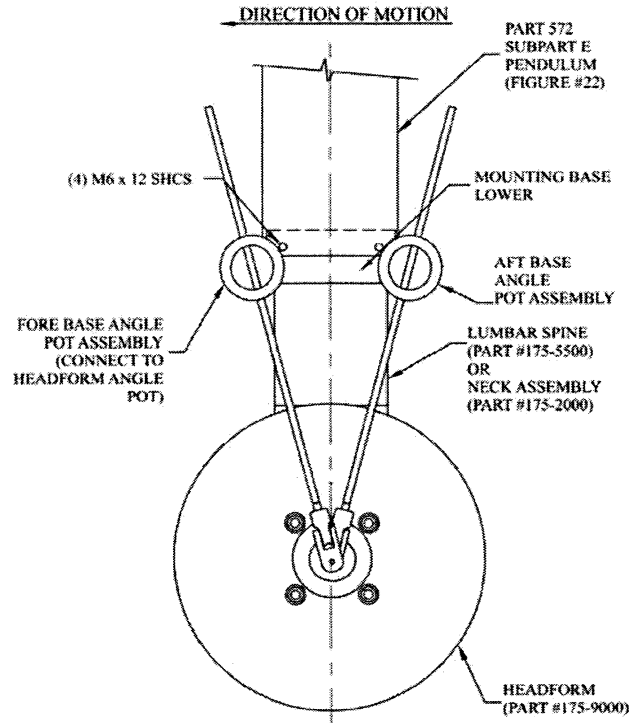


Figure U2-B
ANGLE MEASUREMENTS WITH HEADFORM SET-UP

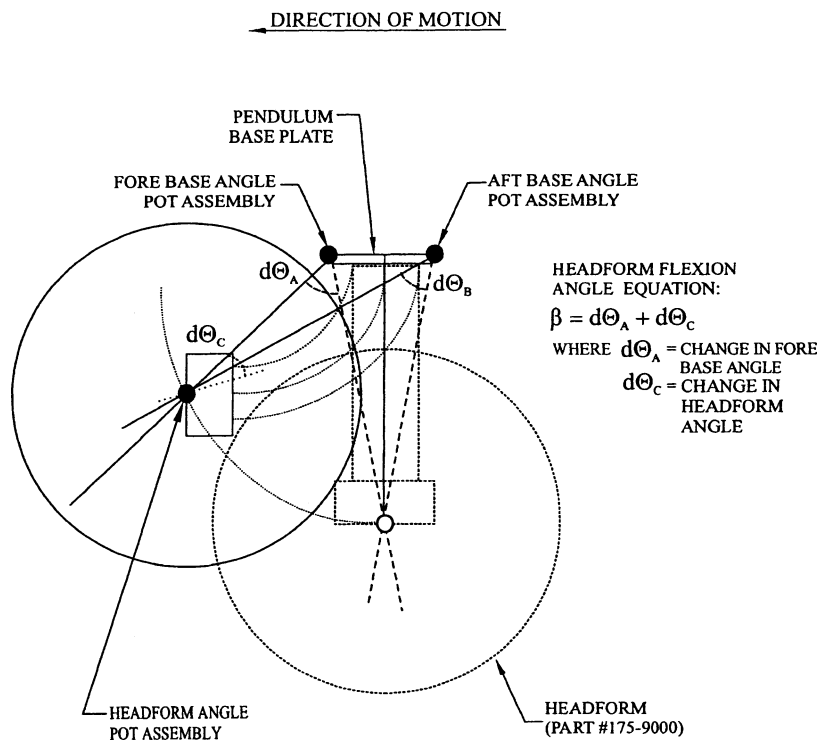


Figure U3
SHOULDER IMPACT

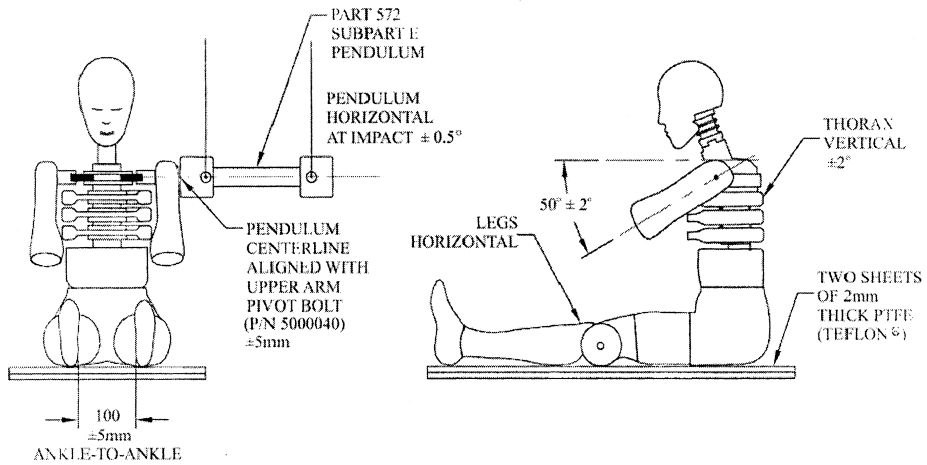


Figure U4
THORAX IMPACT

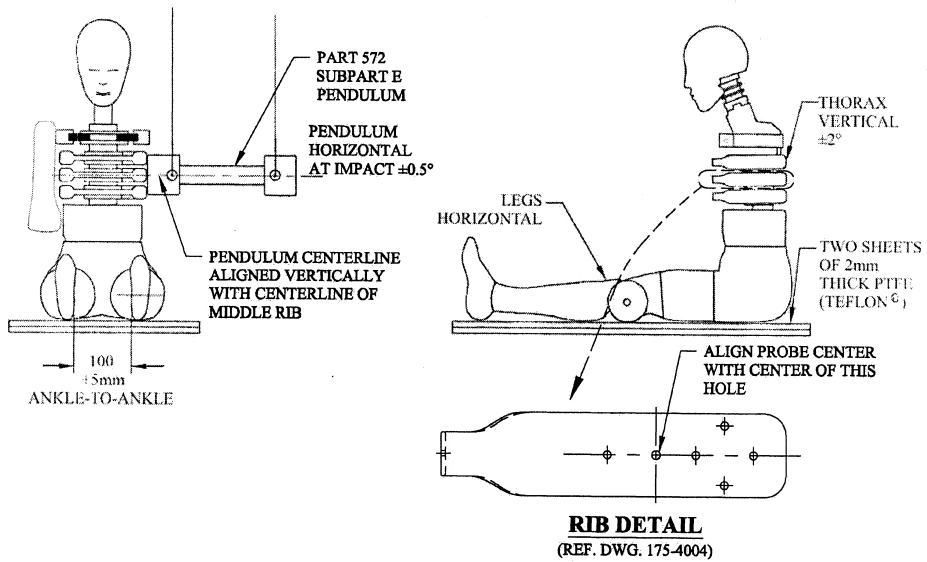


Figure U5
ABDOMEN IMPACT

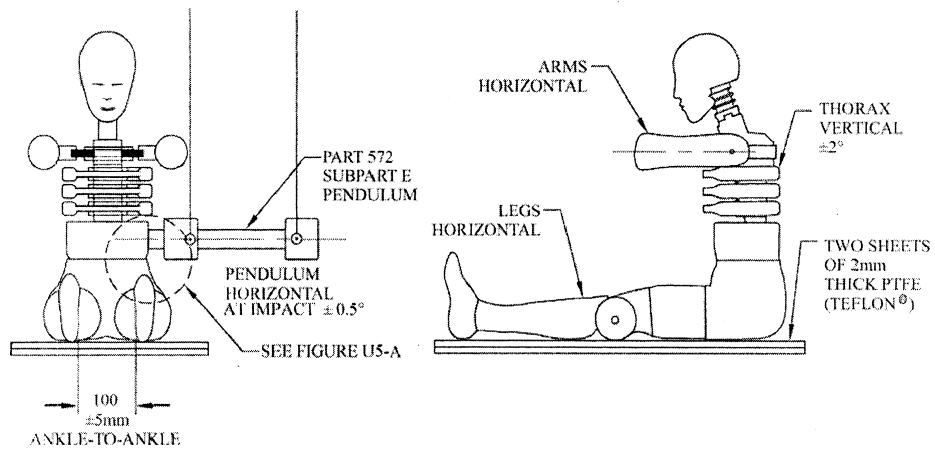


Figure U5-A
ABDOMEN IMPACT - VIEW A

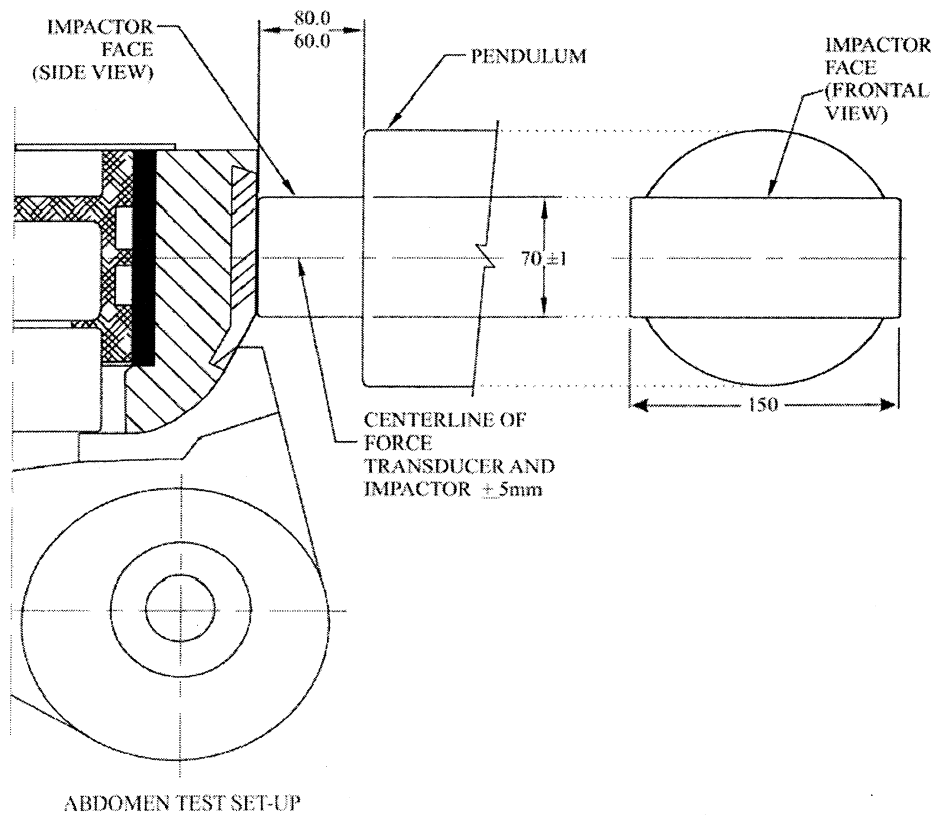


Figure U6
PELVIS IMPACT

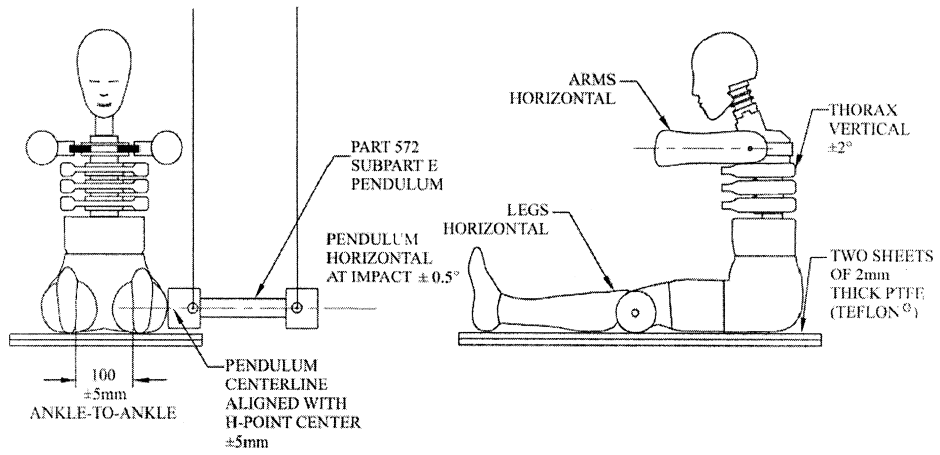
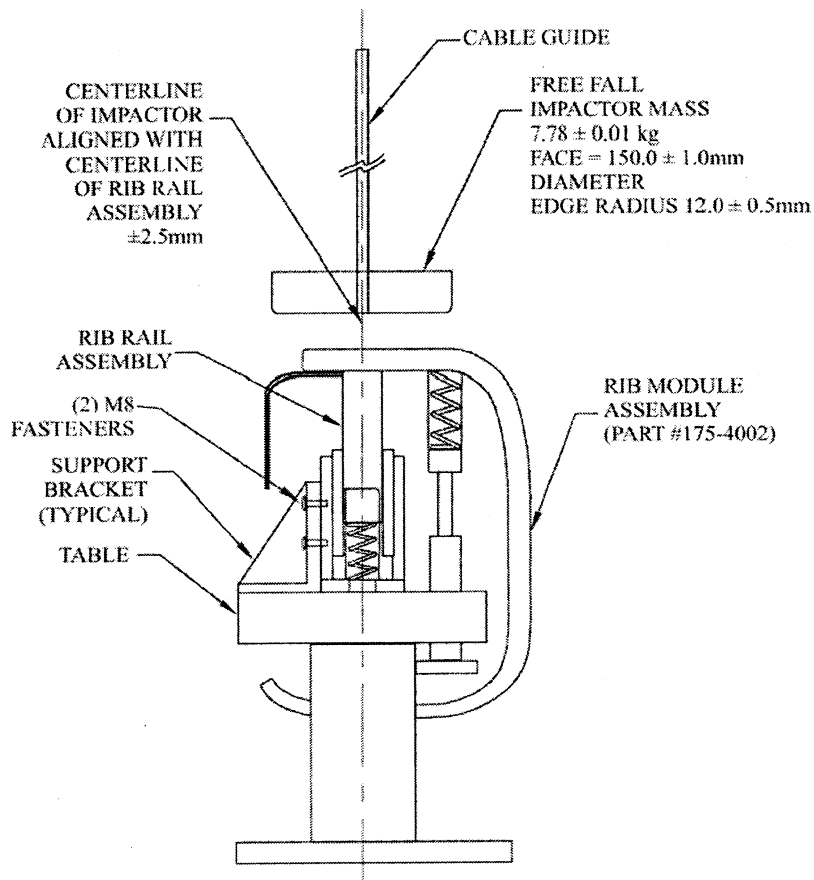


Figure U7
RIB DROP TEST



[71 FR 75331, Dec. 14, 2006, as amended at 73 FR 33921, June 16, 2008]

Subpart V, SID-IIsD Side Impact Crash Test Dummy, Small Adult Female

SOURCE: 71 FR 75370, Dec. 14, 2006, unless otherwise noted.

§ 572.190 Incorporated materials.

(a) The following materials are hereby incorporated into this Subpart by reference:

(1) A parts/drawing list entitled, "Parts/Drawings List, Part 572 Subpart V, SID-IIsD, July 1, 2008,"

(2) A drawings and inspection package entitled "Drawings and Specifications for the SID-IIsD Small Female Crash Test Dummy, Part 572 Subpart V, July 1, 2008," consisting of:

- (i) Drawing No. 180-0000, SID-IIsD Complete Assembly;
- (ii) Drawing No. 180-1000, 6 Axis Head Assembly;
- (iii) Drawing No. 180-2000, Neck Assembly;

- (iv) Drawing No. 180-3000, Upper Torso Assembly;
- (v) Drawing No. 180-3005, Washer, Clamping;
- (vi) Drawing No. 9000021, Screw, SHCS 3/8-16 x 1 NYLOK;
- (vii) Drawing No. 900005, Screw, SHCS 1/4-20 x 5/8 NYLOK;
- (viii) Drawing No. 180-4000, Lower Torso Assembly Complete;
- (ix) Drawing No. 180-5000-1, Complete Leg Assembly, Left;
- (x) Drawing No. 180-5000-2, Complete Leg Assembly, Right;
- (xi) Drawing No. 180-6000-1, Arm Assembly Left Molded;
- (xii) Drawing No. 180-6000-2, Arm Assembly Right Molded; and,
- (xiii) Drawing No. 180-9000, SID-IIsD Headform Assembly.

(3) A procedures manual entitled, "Procedures for Assembly, Disassembly, and Inspection (PADI) of the SID-IIsD Side Impact Crash Test Dummy, July 1, 2008," incorporated by reference in §572.191;

(4) SAE Recommended Practice J211, Rev. Mar 95 "Instrumentation for Impact Tests—Part 1—Electronic Instrumentation"; and,

(5) SAE J1733 of 1994-12, "Sign Convention for Vehicle Crash Testing."

(b) The Director of the Federal Register approved the materials incorporated by reference in accordance with 5 U.S.C. 552(a) and 1 CFR part 51. Copies of the materials may be inspected at the Department of Transportation, Docket Operations, Room W12-140, 1200 New Jersey Avenue, SE., Washington, DC 20590, telephone (202) 366-9826, and at the National Archives and Records Administration (NARA), and in electronic format through Regulations.gov. For information on the availability and inspection of this material at NARA, call 202-741-6030, or go to:

http://www.archives.gov/federal_register/code_of_federal_regulations/ibr_locations.html. For information on the availability and inspection of this material at Regulations.gov, call 1-877-378-5457, or go to: <http://www.regulations.gov>.

(c) The incorporated materials are available as follows:

(1) The Parts/Drawings List, Part 572 Subpart V, SID-IIsD, July 1, 2008, re-

ferred to in paragraph (a)(1) of this section, the package entitled Drawings and Specifications for SID-IIsD Small Female Crash Test Dummy, Part 572 Subpart V, July 1, 2008, referred to in paragraph (a)(2) of this section, and the PADI document referred to in paragraph (a)(3) of this section, are available in electronic format through www.Regulations.gov and in paper format from Leet-Melbrook, Division of New RT, 18810 Woodfield Road, Gaithersburg, MD 20879, (301) 670-0090.

(2) The SAE materials referred to in paragraphs (a)(4) and (a)(5) of this section are available from the Society of Automotive Engineers, Inc., 400 Commonwealth Drive, Warrendale, PA 15096, telephone 1-877-606-7323.

[71 FR 75370, Dec. 14, 2006, as amended at 74 FR 29894, June 23, 2009]

§572.191 General description.

(a) The SID-IIsD Side Impact Crash Test Dummy, small adult female, is defined by:

(1) The drawings and specifications contained in the "Drawings and Specifications for SID-IIsD Small Female Crash Test Dummy, Part 572 Subpart V, July 1, 2008," which includes the technical drawings and specifications described in Drawing 180-0000, the titles of which are listed in Table A;

TABLE A

Component assembly	Drawing number
6 Axis Head Assembly	180-1000
Neck Assembly	180-2000
Upper Torso Assembly	180-3000
Clamping Washer	180-3005
Lower Torso Assembly Complete	180-4000
Complete Leg Assembly, Left	180-5000-1
Complete Leg Assembly, Right	180-5000-2
Arm Assembly Left Molded	180-6000-1
Arm Assembly Right Molded	180-6000-2

(2) The "Parts/Drawing List, Part 572 Subpart V, SID-IIsD," dated July 1, 2008 and containing 7 pages,

(3) A listing of available transducers-crash test sensors for the SID-IIsD Side Impact Crash Test Dummy, 5th percentile adult female, is shown in drawing 180-0000 sheet 2 of 5, dated July 1, 2008,

(4) "Procedures for Assembly, Disassembly, and Inspection (PADI) of the

§ 572.192

SID-IIsD Side Impact Crash Test Dummy, July 1, 2008,” and,

(5) Sign convention for signal outputs reference document SAE J1733 Information Report, titled “Sign Convention for Vehicle Crash Testing,” dated July 12, 1994, incorporated by reference in § 572.200(k).

(b) Exterior dimensions of the SID-IIsD Small Adult Female Side Impact Crash Test Dummy are shown in drawing 180-0000 sheet 3 of 5, dated July 1, 2008.

(c) Weights and center of gravity locations of body segments are shown in drawing 180-0000 sheet 4 of 5, dated July 1, 2008.

(d) Adjacent segments are joined in a manner such that, except for contacts existing under static conditions, there is no additional contact between metallic elements of adjacent body segments throughout the range of motion.

(e) The structural properties of the dummy are such that the dummy conforms to this Subpart in every respect before use in any test similar to that set forth in Standard 214, Side Impact Protection (49 CFR 571.214).

[71 FR 75370, Dec. 14, 2006, as amended at 74 FR 29895, June 23, 2009]

§ 572.192 Head assembly.

(a) The head assembly consists of the head (180-1000) and a set of three (3) accelerometers in conformance with specifications in 49 CFR 572.200(d) and mounted as shown in drawing 180-0000 sheet 2 of 5. When tested to the procedure specified in paragraph (b) of this section, the head assembly shall meet performance requirements specified in paragraph (c) of this section.

(b) *Test procedure.* The head shall be tested according to the procedure specified in 49 CFR 572.112(a).

(c) *Performance criteria.*

(1) When the head assembly is dropped from either the right or left lateral incline orientations in accordance with procedure in § 572.112(a), the measured peak resultant acceleration shall be between 115 g and 137 g;

(2) The resultant acceleration-time curve shall be unimodal to the extent that oscillations occurring after the main acceleration pulse shall not exceed 15% (zero to peak) of the main pulse;

49 CFR Ch. V (10-1-10 Edition)

(3) The longitudinal acceleration vector (anterior-posterior direction) shall not exceed 15 g.

§ 572.193 Neck assembly.

(a) The neck assembly consists of parts shown in drawing 180-2000. For purposes of this test, the neck assembly is mounted within the headform assembly (180-9000) as shown in Figure V1 in appendix A to this subpart. When subjected to the test procedure specified in paragraph (b) of this section, the neck-headform assembly shall meet the performance requirements specified in paragraph (c) of this section.

(b) *Test procedure.*

(1) Soak the assembly in a test environment as specified in 49 CFR 572.200(j);

(2) Attach the neck-headform assembly, as shown in Figure V2-A or V2-B in appendix A to this subpart, to the 49 CFR Part 572 pendulum test fixture (Figure 22, 49 CFR 572.33) in either the left or right lateral impact orientations, respectively, so that the midsagittal plane of the neck-headform assembly is vertical and at right angle (90 ± 1 degrees) to the plane of motion of the pendulum longitudinal centerline;

(3) Release the pendulum from a height sufficient to achieve a velocity of 5.57 ± 0.06 m/s measured at the center of the pendulum accelerometer, as shown in 49 CFR Part 572 Figure 15, at the instant the pendulum makes contact with the decelerating mechanism;

(4) The neck flexes without the neck-headform assembly making contact with any object;

(5) Time zero is defined as the time of initial contact between the pendulum mounted striker plate and the pendulum deceleration mechanism;

(6) Allow a period of at least thirty (30) minutes between successive tests on the same neck assembly.

(c) *Performance Criteria.*

(1) The pendulum deceleration pulse is characterized in terms of decrease in velocity as obtained by integrating the pendulum acceleration output from time zero;

Time(ms)	Peak pendulum delta-V(m/s)
10.0	-2.20 to -2.80
15.0	-3.30 to -4.10
20.0	-4.40 to -5.40
25.0	-5.40 to -6.10
>25.0 < 100	-5.50 to -6.20

(2) The maximum translation-rotation of the midsagittal plane of the headform disk (180-9061 or 9062) in the lateral direction measured, with the rotation transducers specified in 49 CFR 572.200(e) shall be 71 to 81 degrees with respect to the longitudinal axis of the pendulum (see Figure V2-C in appendix A to this subpart) occurring between 50 and 70 ms from time zero;

(3) Peak occipital condyle moment shall not be higher than -36 Nm and not lower than -44 Nm. The moment measured by the upper neck load cell (Mx) shall be adjusted by the following formula: $Mx(oc)^1 = Mx + 0.01778Fy$;

(4) The decaying moment shall cross the 0 Nm line after peak moment between 102 ms-126 ms after time zero.

[71 FR 75370, Dec. 14, 2006, as amended at 74 FR 29895, June 23, 2009]

§ 572.194 Shoulder.

(a) The shoulder structure is part of the upper torso assembly shown in drawing 180-3000. For the shoulder impact test, the dummy is tested as a complete assembly (drawing 180-0000). The dummy is equipped with T1 laterally oriented accelerometer as specified in 49 CFR 572.200(d), and deflection potentiometer as specified in 180-3881 configured for shoulder and installed as shown in drawing 180-0000 sheet 2 of 5. When subjected to the test procedure as specified in paragraph (b) of this section, the shoulder shall meet the performance requirements of paragraph (c) of this section.

(b) *Test procedure.* (1) Soak the dummy assembly (180-0000) in a test environment as specified in 49 CFR 572.200(j).

(2) Seat the dummy, outfitted with the torso jacket (180-3450) and cotton underwear pants on a certification bench, specified in Figure V3 in appendix A to this subpart, the seat pan and

¹Mx(oc) is the moment at occipital condyle (Newton-meters) and Fy is the lateral shear force (Newtons) measured by the load cell.

the seatback surfaces of which are covered with a 2 mm thick PTFE (Teflon) sheet;

(3) Align the outermost portion of the pelvis flesh of the impacted side of the seated dummy tangent to a vertical plane located within 10 mm of the side edge of the bench as shown in Figure V4-A in appendix A to this subpart, while the midsagittal plane of the dummy is in vertical orientation.

(4) Push the dummy at the knees and at mid-sternum of the upper torso with just sufficient horizontally oriented force towards the seat back until the back of the upper torso is in contact with the seat back.

(5) While maintaining the dummy's position as specified in paragraphs (b)(3) and (4) of this section, the top of the shoulder rib mount (drawing 180-3352) orientation in the fore-and-aft direction is 24.6 ± 2.0 degrees relative to horizontal, as shown in Figure V4-B in appendix A to this subpart.

(6) Adjust orientation of the legs such that they are symmetrical about the mid-sagittal plane, the thighs touch the seat pan, the inner part of the right and left legs at the knees are as close as possible to each other, the heels touch the designated foot support surface and the feet are vertical and as close together as possible.

(7) Orient the arm to point forward at 90 ± 2 degrees relative to the inferior-superior orientation of the upper torso spine box incline.

(8) The impactor is specified in 49 CFR 572.200(a).

(9) The impactor is guided, if needed, so that at contact with the dummy's arm rotation centerline (ref. item 23 in drawing 180-3000) the impactor's longitudinal axis is within ± 1 degree of a horizontal plane and perpendicular to the midsagittal plane of the dummy. The centerpoint of the impactor face at contact is within 2 mm of the shoulder yoke assembly rotation centerline (drawing 180-3327), as shown in Figure V4-A in appendix A to this subpart.

(10) The dummy's arm-shoulder is impacted at 4.3 ± 0.1 m/s with the impactor meeting the alignment and contact point requirements of paragraph (b)(9) of this section.

§ 572.195

(11) Allow a period of at least thirty (30) minutes between successive tests of the same shoulder assembly.

(c) *Performance criteria.*

(1) While the impactor is in contact with the dummy's arm, the shoulder shall compress not less than 28 mm and not more than 37 mm measured by the potentiometer specified in (a);

(2) Peak lateral acceleration of the upper spine (T1) shall not be less than 17 g and not more than 22 g;

(3) Peak impactor acceleration shall be not less than 13 g and not more than 18 g.

[71 FR 75370, Dec. 14, 2006, as amended at 74 FR 29895, June 23, 2009]

§ 572.195 Thorax with arm.

(a) The thorax is part of the upper torso assembly shown in drawing 180-3000. For the thorax with arm impact test, the dummy is tested as a complete assembly (drawing 180-0000). The dummy's thorax is equipped with T1 and T12 laterally oriented accelerometers as specified in 49 CFR 572.200(d), and deflection potentiometers for the thorax and shoulder as specified in 180-3881, installed as shown in drawing 180-0000 sheet 2 of 5. When subjected to the test procedure as specified in paragraph (b) of this section, the thorax shall meet performance requirements of paragraph (c) of this section.

(b) *Test procedure.* (1) Soak the dummy assembly (180-0000) in a test environment as specified in 49 CFR 572.200(j).

(2) Seat the dummy, outfitted with the torso jacket (180-3450) and cotton underwear pants on a certification bench, specified in Figure V3, the seat pan and the seatback surfaces of which are covered with a 2-mm-thick PTFE (Teflon) sheet.

(3) Align the outermost portion of the pelvis flesh of the impacted side of the seated dummy tangent to a vertical plane located within 10 mm of the side edge of the bench as shown in Figure V5-A, while the midsagittal plane of the dummy is in vertical orientation.

(4) Push the dummy at the knees and at mid-sternum of the upper torso with just sufficient horizontally oriented force towards the seat back until the

49 CFR Ch. V (10-1-10 Edition)

back of the upper torso is in contact with the seat back.

(5) While maintaining the dummy's position as specified in paragraphs (b)(3) and (4) of this section, the top of the shoulder rib mount (drawing 180-3352) orientation in the fore-and-aft direction is 24.6 ± 2.0 degrees relative to horizontal as shown in Figure V5-B in appendix A to this subpart.

(6) Adjust orientation of the legs such that they are symmetrical about the mid-sagittal plane, the thighs touch the seat pan, the inner part of the right and left legs at the knees are as close as possible to each other, the heels touch the designated foot support surface and the feet are vertical and as close together as possible.

(7) Orient the arm downward to the lowest detent such that the longitudinal centerline of the arm is parallel to the inferior-superior orientation of the spine box.

(8) The impactor is specified in 49 CFR 572.200(a).

(9) The impactor is guided, if needed, so that at contact with the dummy's arm, its longitudinal axis is within ± 1 degree of a horizontal plane and perpendicular to the midsagittal plane of the dummy. The centerpoint of the impactor face is within 2 mm of the vertical midpoint of the second thoracic rib and coincident with a line parallel to the seat back incline passing through the center of the shoulder yoke assembly arm rotation pivot (drawing 180-3327), as shown in Figure V5-A in appendix A to this subpart.

(10) The dummy's arm is impacted at 6.7 ± 0.1 m/s.

(11) Time zero is defined as the time of contact between the impact probe and the arm.

(12) Allow a period of at least thirty (30) minutes between successive tests of the same thorax assembly.

(c) *Performance criteria.*

(1) While the impactor is in contact with the dummy's arm, the thoracic ribs and the shoulder shall conform to the following range of deflections:

(i) Shoulder not less than 31 mm and not more than 40 mm;

(ii) Upper thorax rib not less than 25 mm and not more than 32 mm;

(iii) Middle thorax rib not less than 30 mm and not more than 36 mm;

(iv) Lower thorax rib not less than 32 mm and not more than 38 mm;

(2) Peak lateral acceleration of the upper spine (T1) shall not be less than 34 g and not more than 43 g, and the lower spine (T12) not less than 29 g and not more than 37 g;

(3) Peak impactor acceleration after 5 ms after time zero shall be not less than 30 g and not more than 36 g.

[71 FR 75370, Dec. 14, 2006, as amended at 74 FR 29895, June 23, 2009]

§ 572.196 Thorax without arm.

(a) The thorax is part of the upper torso assembly shown in drawing 180-3000. For this thorax test, the dummy is tested as a complete assembly (drawing 180-0000) with the arm (180-6000) on the impacted side removed. The dummy's thorax is equipped with T1 and T12 laterally oriented accelerometers as specified in 49 CFR 572.200(d) and with deflection potentiometers for the thorax as specified in drawing 180-3881, installed as shown in drawing 180-0000 sheet 2 of 5. When subjected to the test procedure specified in paragraph (b) of this section, the thorax shall meet the performance requirements set forth in paragraph (c) of this section.

(b) *Test procedure.* (1) Soak the dummy assembly (180-0000) in a test environment as specified in 49 CFR 572.200(j).

(2) Seat the dummy, outfitted with the torso jacket (180-3450) and cotton underwear pants on a calibration bench, specified in Figure V3 in appendix A to this subpart, the seat pan and the seatback surfaces of which are covered with a 2-mm-thick PTFE (Teflon) sheet.

(3) Align the outermost portion of the pelvis flesh of the impacted side of the seated dummy tangent to a vertical plane located within 10 mm of the side edge of the bench as shown in Figure V6-A, while the midsagittal plane of the dummy is in vertical orientation.

(4) Push the dummy at the knees and at mid-sternum of the upper torso with just sufficient horizontally oriented force towards the seat back until the back of the upper torso is in contact with the seat back.

(5) While maintaining the dummy's position as specified in paragraphs

(b)(3) and (4) of this section, the top of the shoulder rib mount (drawing 180-3352) orientation in the fore-and-aft direction is 24.6 ± 2.0 degrees relative to horizontal, as shown in Figure V6-B in appendix A to this subpart.

(6) Adjust orientation of the legs such that they are symmetrical about the mid-sagittal plane, the thighs touch the seat pan, the inner part of the right and left legs at the knees are as close as possible to each other, the heels touch the designated foot support surface and the feet are vertical and as close together as possible.

(7) The impactor is specified in 49 CFR 572.200(a).

(8) The impactor is guided, if needed, so that at contact with the thorax, its longitudinal axis is within 1 degree of a horizontal plane and perpendicular to the midsagittal plane of the dummy. The centerpoint of the impactor face is within 2 mm of the vertical midpoint of the second thorax rib and coincident with a line parallel to the seat back incline passing through the center of the shoulder yoke assembly arm rotation pivot (drawing 180-3327), as shown in Figure V6-A in appendix A to this subpart.

(9) The dummy's thorax is impacted at 4.3 ± 0.1 m/s.

(10) Allow a period of at least thirty (30) minutes between successive tests of the same thorax assembly.

(c) *Performance criteria.*

(1) While the impactor is in contact with the dummy's thorax, the ribs shall conform to the following range of deflections:

(i) Upper thorax rib not less than 32 mm and not more than 40 mm;

(ii) Middle thorax rib not less than 39 mm and not more than 45 mm;

(iii) Lower thorax rib not less than 35 mm and not more than 43 mm;

(2) Peak acceleration of the upper spine (T1) shall not be less than 13 g and not more than 17 g and the lower spine (T12) not less than 7 g and not more than 11 g;

(3) Peak impactor acceleration shall not be less than 14 g and not more than 18 g.

[71 FR 75370, Dec. 14, 2006, as amended at 74 FR 29895, June 23, 2009]

§ 572.197

49 CFR Ch. V (10–1–10 Edition)

§ 572.197 Abdomen.

(a) The abdomen assembly is part of the upper torso assembly (180–3000) and is represented by two ribs (180–3368) and two linear deflection potentiometers (180–3881). The abdomen test is conducted on the complete dummy assembly (180–0000) with the arm (180–6000) on the impacted side removed. The dummy is equipped with a lower spine laterally oriented accelerometer as specified in 49 CFR 572.200(d) and deflection potentiometers specified in drawing 180–3881, installed as shown in sheet 2 of drawing 180–0000. When subjected to the test procedure as specified in paragraph (b) of this section, the abdomen shall meet performance requirements of paragraph (c) of this section.

(b) *Test procedure.* (1) Soak the dummy assembly (180–0000) in a test environment as specified in 49 CFR 572.200(j).

(2) Seat the dummy, outfitted with the torso jacket (180–3450) and cotton underwear pants on a calibration bench, specified in Figure V3, the seat pan and the seatback surfaces of which are covered with a 2 mm thick PTFE (Teflon) sheet.

(3) Align the outermost portion of the pelvis flesh of the impacted side of the seated dummy tangent to a vertical plane located within 10 mm of the side edge of the bench as shown in Figure V7–A in Appendix A to this subpart, while the midsagittal plane of the dummy is in vertical orientation.

(4) Push the dummy at the knees and at mid-sternum of the upper torso with just sufficient horizontally oriented force towards the seat back until the back of the upper torso is in contact with the seat back.

(5) While maintaining the dummy's position as specified in paragraph (b)(3) and (4) of this section, the top of the shoulder rib mount (drawing 180–3352) orientation in the fore-and-aft direction is 24.6 ± 2.0 degrees relative to horizontal, as shown in Figure V7–B in appendix A to this subpart);

(6) Adjust orientation of the legs such that they are symmetrical about the mid-sagittal plane, the thighs touch the seat pan, the inner part of the right and left legs at the knees are as close as possible to each other, the

heels touch the designated foot support surface and the feet are vertical and as close together as possible;

(7) The impactor is specified in 49 CFR 572.200(b);

(8) The impactor is guided, if needed, so that at contact with the abdomen, its longitudinal axis is within ± 1 degree of a horizontal plane and perpendicular to the midsagittal plane of the dummy and the centerpoint of the impactor's face is within 2 mm of the vertical midpoint between the two abdominal ribs and coincident with a line parallel to the seat back incline passing through the center of the shoulder yoke assembly arm rotation pivot (drawing 180–3327), as shown in Figure V7–A in appendix A to this subpart;

(9) The dummy's abdomen is impacted at 4.3 ± 0.1 m/s.

(10) Allow a period of at least thirty (30) minutes between successive tests of the same abdomen assembly.

(c) *Performance criteria.* (1) While the impact probe is in contact with the dummy's abdomen, the deflection of the upper abdominal rib shall be not less than 36 mm and not more than 47 mm, and the lower abdominal rib not less than 33 mm and not more than 44 mm.

(2) Peak acceleration of the lower spine (T12) laterally oriented accelerometer shall be not less than 9 g and not more than 14 g;

(3) Peak impactor acceleration shall be not less than 12 g and not more than 16 g.

[71 FR 75370, Dec. 14, 2006, as amended at 74 FR 29896, June 23, 2009]

§ 572.198 Pelvis acetabulum.

(a) The acetabulum is part of the lower torso assembly shown in drawing 180–4000. The acetabulum test is conducted by impacting the side of the lower torso of the assembled dummy (drawing 180–0000). The dummy is equipped with a laterally oriented pelvis accelerometer as specified in 49 CFR 572.200(d), acetabulum load cell SA572–S68, mounted as shown in sheet 2 of 5 of drawing 180–0000, and an unused and certified pelvis plug (180–4450). When subjected to the test procedure as specified in paragraph (b) of this section, the pelvis shall meet performance

requirements of paragraph (c) of this section.

(b) *Test procedure.* (1) Soak the dummy assembly (180-0000) in a test environment as specified in 49 CFR 572.200(j).

(2) Seat the dummy, without the torso jacket (180-3450) and without cotton underwear pants, as shown in Figure V8-A in appendix A to this subpart, on a calibration bench, specified in Figure V3 in appendix A to this subpart, with the seatpan and the seatback surfaces covered with a 2-mm-thick PTFE (Teflon) sheet;

(3) Align the outermost portion of the pelvis flesh of the impacted side of the seated dummy tangent to a vertical plane located within 10 mm of the side edge of the bench as shown in Figure V8-A in appendix A to this subpart, while the midsagittal plane of the dummy is in vertical orientation.

(4) Push the dummy at the knees and at mid-sternum of the upper torso with just sufficient horizontally oriented force towards the seat back until the back of the upper torso is in contact with the seat back.

(5) While maintaining the dummy's position as specified in paragraphs (b)(3) and (4) of this section, the top of the shoulder rib mount (drawing 180-3352) orientation in the fore-and-aft direction is 24.6 ± 1.0 degrees relative to horizontal, as shown in Figure V8-B in appendix A to this subpart;

(6) Adjust orientation of the legs such that they are symmetrical about the mid-sagittal plane, the thighs touch the seat pan, the inner part of the right and left legs at the knees are as close as possible to each other, the heels touch the designated foot support surface and the feet are vertical and as close together as possible.

(7) Rotate the arm downward to the lowest detent such that the longitudinal centerline of the arm is parallel to the inferior-superior orientation of the spine box.

(8) The impactor is specified in 49 CFR 572.200(a).

(9) The impactor is guided, if needed, so that at contact with the pelvis, its longitudinal axis is within ± 1 degree of a horizontal plane and perpendicular to the midsagittal plane of the dummy. The centerpoint of the impactor's face

is in line within 2 mm of the longitudinal centerline of the $\frac{1}{4}$ -20x $\frac{1}{2}$ flat head cap screw through the center of the acetabulum load cell (SA572-S68), as shown in Figure V8-A in appendix A to this subpart;

(11) Time zero is defined as the time of contact between the impact probe and the pelvis plug.

(12) Allow a period of at least 120 minutes between successive tests of the same pelvis assembly.

(c) *Performance criteria.* While the impactor is in contact with the pelvis:

(1) Peak acceleration of the impactor is not less than 38 g and not more than 47 g;

(2) Peak lateral acceleration of the pelvis after 6 ms after time zero is not less than 34 g and not more than 42 g;

(3) Peak acetabulum force is not less than 3.60 kN and not more than 4.30 kN.

[71 FR 75370, Dec. 14, 2006, as amended at 74 FR 29896, June 23, 2009]

§ 572.199 Pelvis iliac.

(a) The iliac is part of the lower torso assembly shown in drawing 180-4000. The iliac test is conducted by impacting the side of the lower torso of the assembled dummy (drawing 180-0000). The dummy is equipped with a laterally oriented pelvis accelerometer as specified in 49 CFR 572.200(d), and iliac wing load cell SA572-S66, mounted as shown in sheet 2 of 5 of drawing 180-0000. When subjected to the test procedure as specified in paragraph (b) of this section, the pelvis shall meet performance requirements of paragraph (c) of this section.

(b) *Test procedure.* (1) Soak the dummy assembly (180-0000) in a test environment as specified in 49 CFR 572.200(j).

(2) Seat the dummy, without the torso jacket and without cotton underwear pants, as shown in Figure V9-A in appendix A to this subpart, on a flat, rigid, horizontal surface covered with a 2-mm-thick PTFE (Teflon) sheet.

(3) The legs are outstretched in front of the dummy such that they are symmetrical about the midsagittal plane, the thighs touch the seated surface, the inner part of the right and left legs at the knees are as close as possible to each other, and the feet are in full

§ 572.200

dorsiflexion and as close together as possible.

(4) Orient the arm downward to the lowest detent such that the longitudinal centerline of the arm is parallel to the inferior-superior orientation of the spine box.

(5) The midsagittal plane of the dummy is vertical, and superior surface of the lower half neck assembly load cell replacement (180-3815) in the lateral direction is within ± 1 degree relative to the horizontal as shown in Figure V9-A.

(6) While maintaining the dummy's position as specified in paragraphs (b)(3), (4) and (5) of this section, the top of the shoulder rib mount (180-3352) orientation in the fore-and-aft direction is within ± 1.0 degree relative to horizontal as shown in Figure V9-B in Appendix A to this subpart.

(7) The pelvis impactor is specified in 49 CFR 572.200(c).

(8) The dummy is positioned with respect to the impactor such that the longitudinal centerline of the impact probe is in line with the longitudinal centerline of the iliac load cell access hole, and the 88.9 mm dimension of the probe's impact surface is aligned horizontally.

(9) The impactor is guided, if needed, so that at contact with the pelvis, the longitudinal axis of the impactor is within ± 1 degree of a horizontal plane and perpendicular to the midsagittal plane of the dummy.

(10) The dummy's pelvis is impacted at the iliac location at 4.3 ± 0.1 m/s.

(11) Allow a period of at least 120 minutes between successive tests of the same pelvis assembly.

(c) *Performance criteria.* While the impactor is in contact with the pelvis:

(1) Peak acceleration of the impactor is not less than 36 g and not more than 45 g;

(2) Peak acceleration of the pelvis is not less than 28 g and not more than 39 g;

(3) Peak iliac force is not less than 4.10 kN and not more than 5.10 kN.

[71 FR 75370, Dec. 14, 2006, as amended at 74 FR 29896, June 23, 2009]

49 CFR Ch. V (10-1-10 Edition)

§ 572.200 Instrumentation and test conditions.

(a) The test probe for shoulder, lateral thorax, and pelvis-acetabulum impact tests is the same as that specified in 49 CFR 572.137(a) except that its impact face diameter is 120.70 ± 0.25 mm and it has a minimum mass moment of inertia of 3646 kg-cm².

(b) The test probe for the lateral abdomen impact test is the same as that specified in 572.137(a) except that its impact face diameter is 76.20 ± 0.25 mm and it has a minimum mass moment of inertia of 3646 kg-cm².

(c) The test probe for the pelvis-iliac impact tests is the same as that specified in 49 CFR 572.137(a) except that it has a rectangular flat impact surface 50.8×88.9 mm for a depth of at least 76 mm and a minimum mass moment of inertia of 5000 kg-cm².

(d) Accelerometers for the head, the thoracic spine, and the pelvis conform to specifications of SA572-S4.

(e) Rotary potentiometers for the neck-headform assembly conform to SA572-S51.

(f) Instrumentation and sensors conform to the Recommended Practice SAE J-211 (March 1995), Instrumentation for Impact Test, unless noted otherwise.

(g) All instrumented response signal measurements shall be treated to the following specifications:

(1) Head acceleration—digitally filtered CFC 1000;

(2) Neck-headform assembly translation-rotation—digitally filtered CFC 60;

(3) Neck pendulum, T1 and T12 thoracic spine and pelvis accelerations—digitally filtered CFC 180;

(4) Neck forces (for the purpose of occipital condyle calculation) and moments—digitally filtered at CFC 600;

(5) Pelvis, shoulder, thorax and abdomen impactor accelerations—digitally filtered CFC 180;

(6) Acetabulum and iliac wings forces—digitally filtered at CFC 600;

(7) Shoulder, thorax, and abdomen deflection—digitally filtered CFC 600.

(h) Mountings for the head, thoracic spine and pelvis accelerometers shall have no resonant frequency within a range of 3 times the frequency range of the applicable channel class;

Nat'l Highway Traffic Safety Admin., DOT

§ 572.200

(i) Leg joints of the test dummy are set at the force between 1 to 2 g, which just support the limb's weight when the limbs are extended horizontally forward. The force required to move a limb segment does not exceed 2 g throughout the range of the limb motion.

(j) Performance tests are conducted, unless specified otherwise, at any temperature from 20.6 to 22.2 degrees C. (69 to 72 degrees F.) and at any relative

humidity from 10% to 70% after exposure of the dummy to those conditions for a period of 4 hours.

(k) Coordinate signs for instrumentation polarity shall conform to the Sign Convention For Vehicle Crash Testing, Surface Vehicle Information Report, SAE J1733, 1994-12 (refer to §572.191(a)(5)).

[71 FR 75370, Dec. 14, 2006, as amended at 74 FR 29896, June 23, 2009]

APPENDIX A TO SUBPART V OF PART 572—FIGURES

FIGURE V1
NECK ATTACHED TO HEADFORM ASSEMBLY

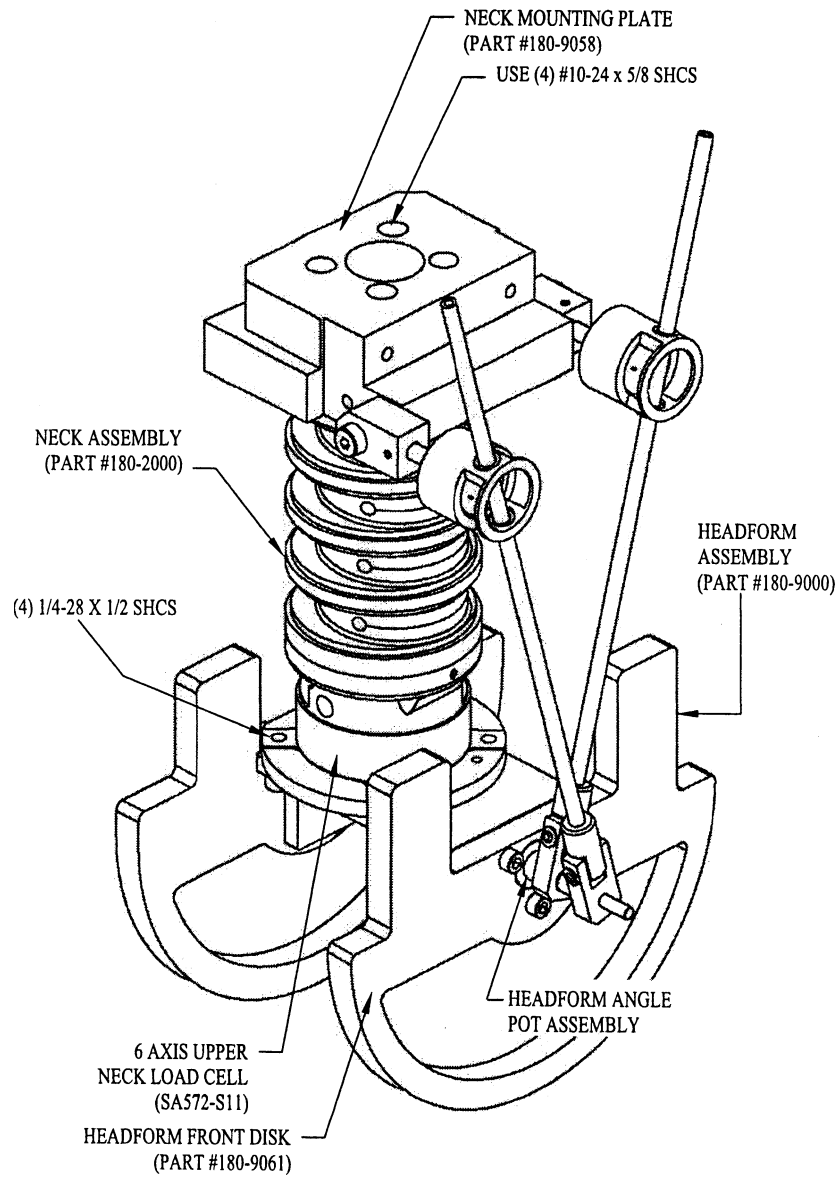


FIGURE V2-A
NECK/HEADFORM ATTACHED TO PENDULUM
FOR LEFT-SIDE IMPACT

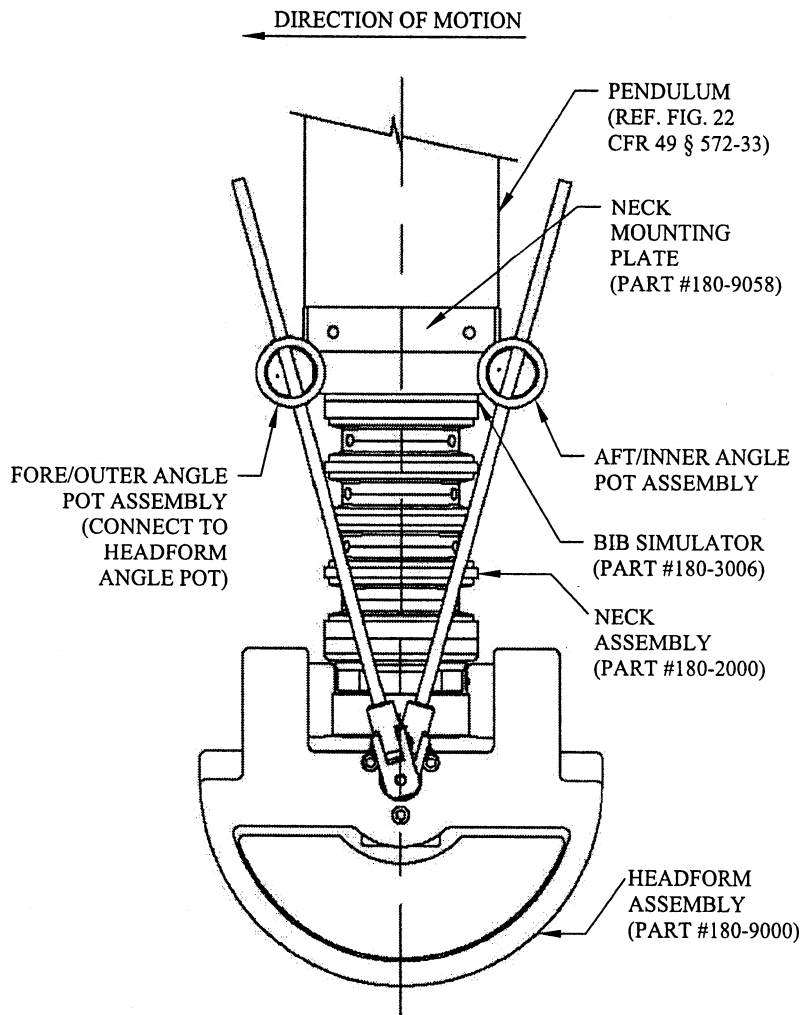


FIGURE V2-B
NECK/HEADFORM ATTACHED TO PENDULUM
FOR RIGHT-SIDE IMPACT

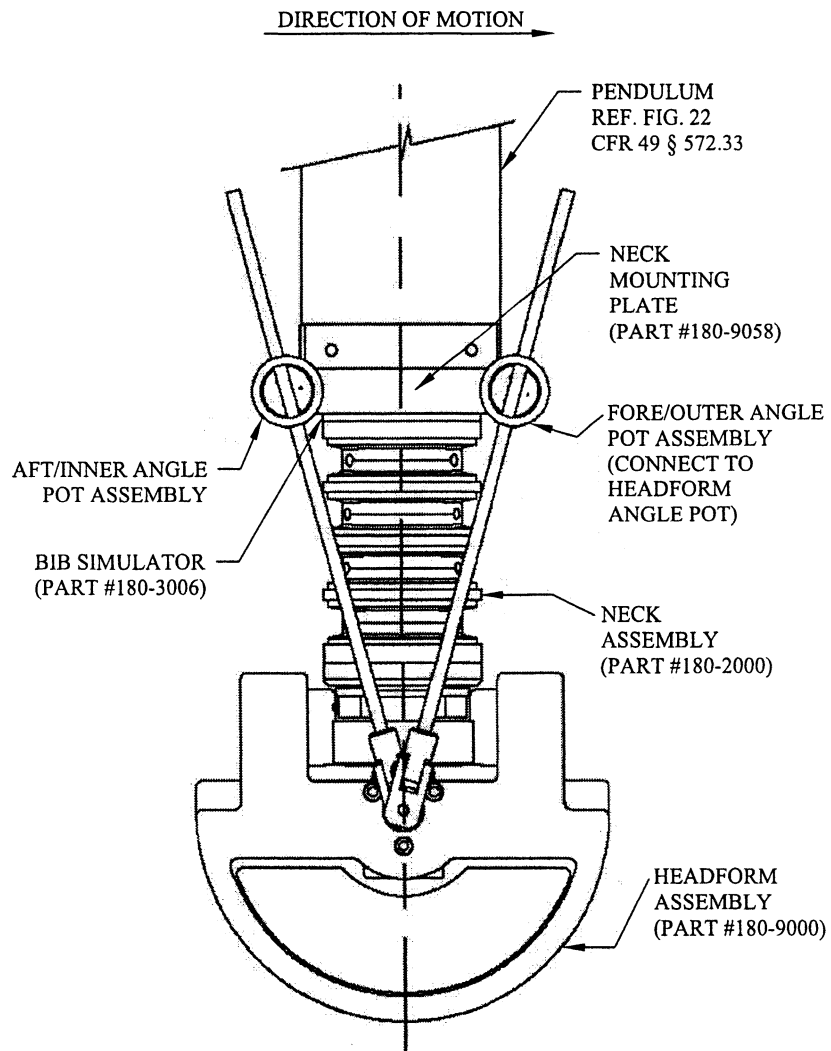
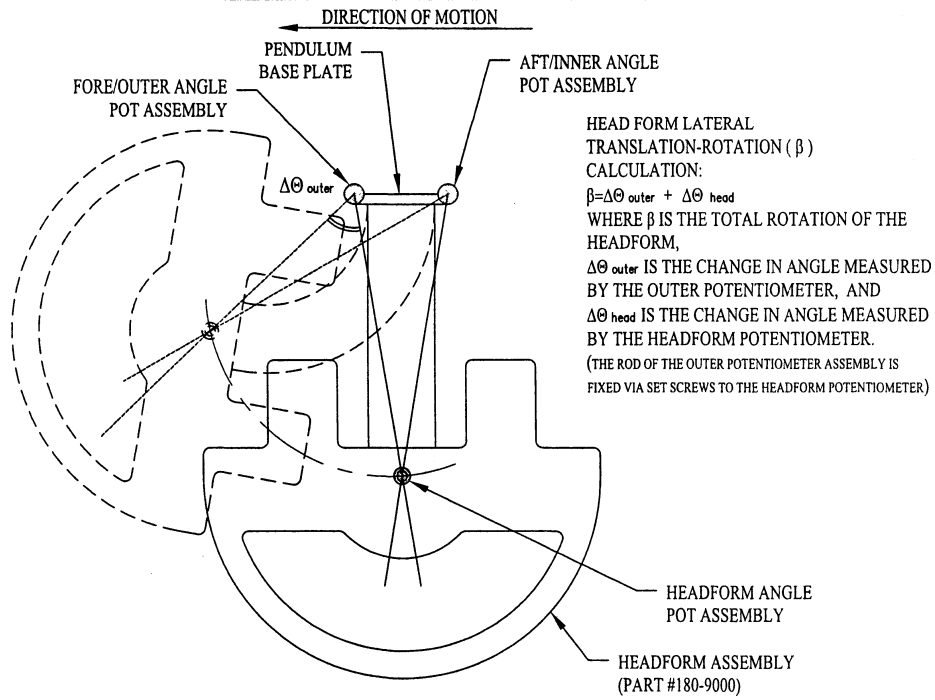
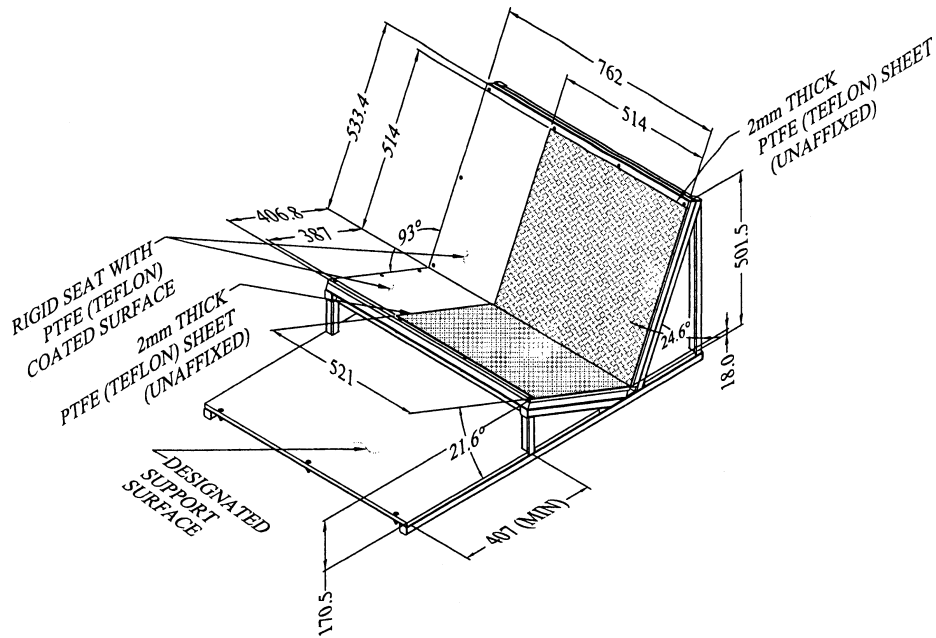


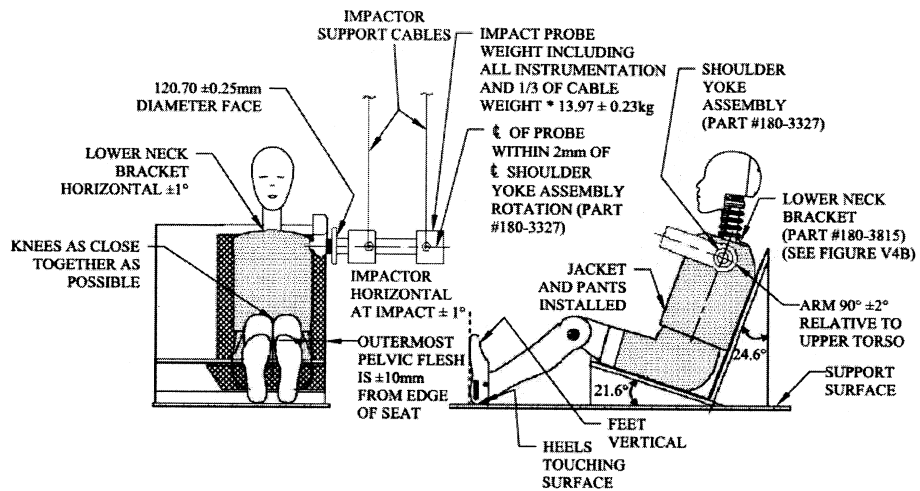
FIGURE V2-C
ANGLE MEASUREMENT WITH HEADFORM SET-UP



**FIGURE V3
CERTIFICATION BENCH**

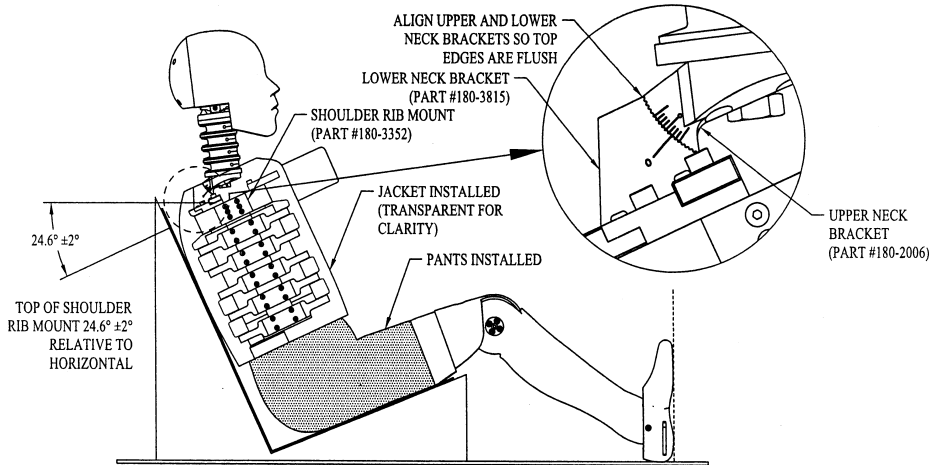


**FIGURE V4-A
SHOULDER IMPACT**

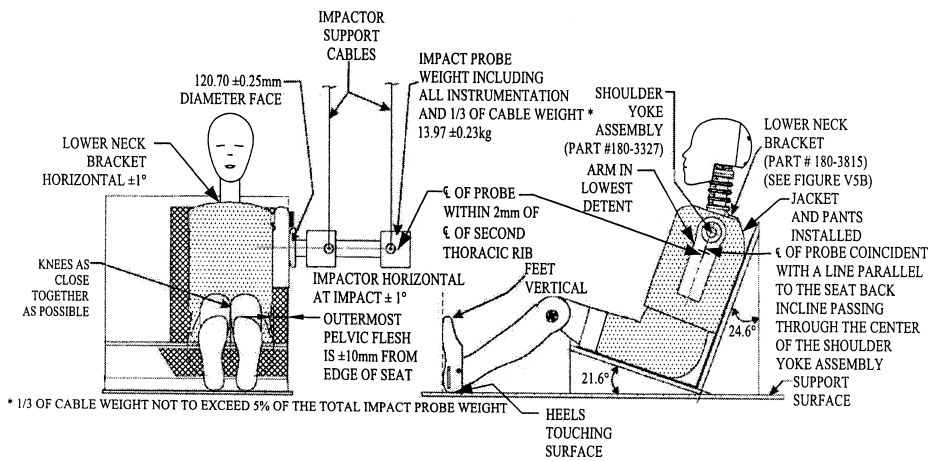


* 1/3 OF CABLE WEIGHT NOT TO EXCEED 5% OF THE TOTAL IMPACTOR PROBE WEIGHT

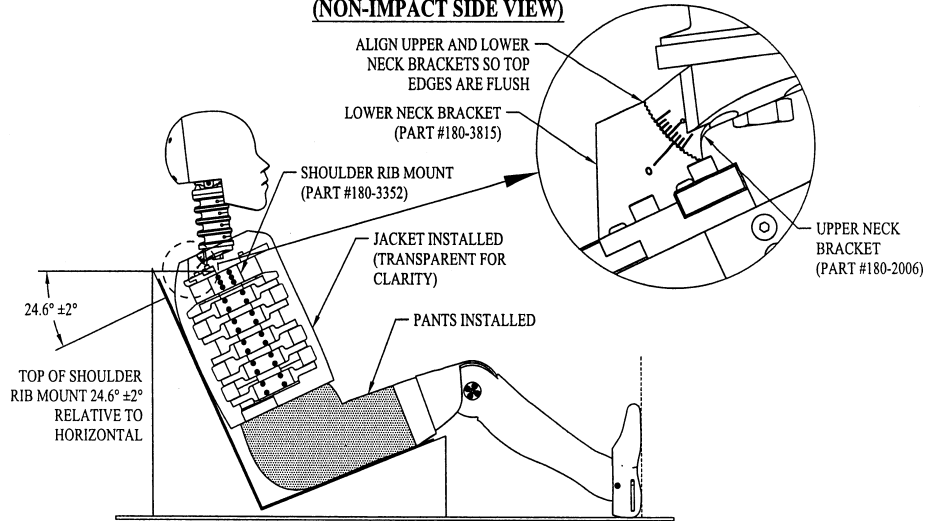
**FIGURE V4-B
SHOULDER IMPACT
(NON-IMPACT SIDE VIEW)**



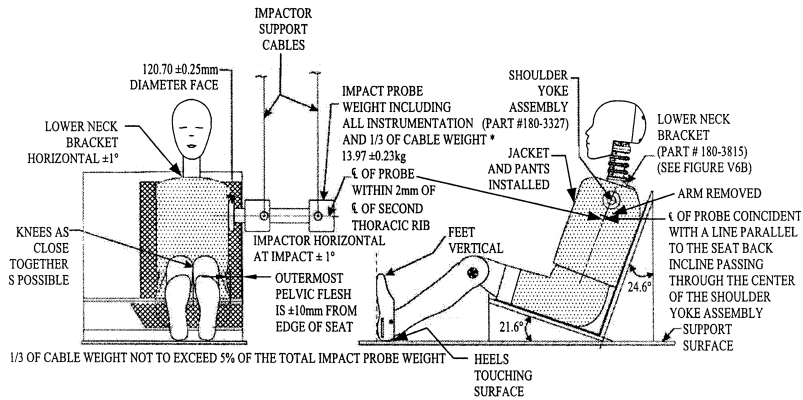
**FIGURE V5-A
THORAX WITH ARM IMPACT**



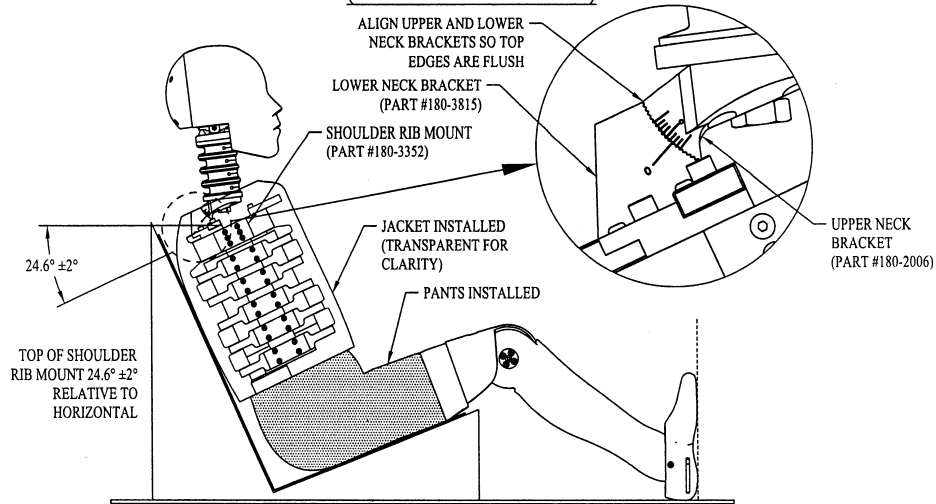
**FIGURE V5-B
THORAX WITH ARM IMPACT
(NON-IMPACT SIDE VIEW)**



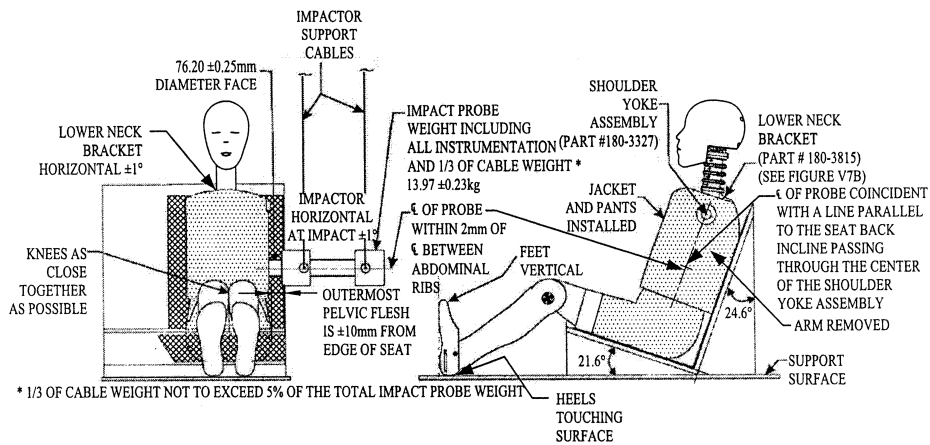
**FIGURE V6-A
THORAX WITHOUT ARM IMPACT**



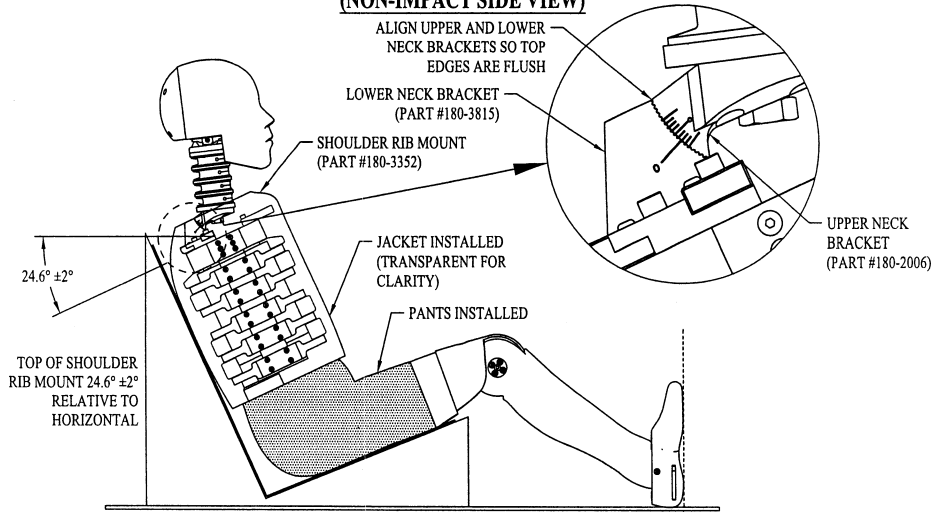
**FIGURE V6-B
THORAX WITHOUT ARM IMPACT
(NON-IMPACT SIDE VIEW)**



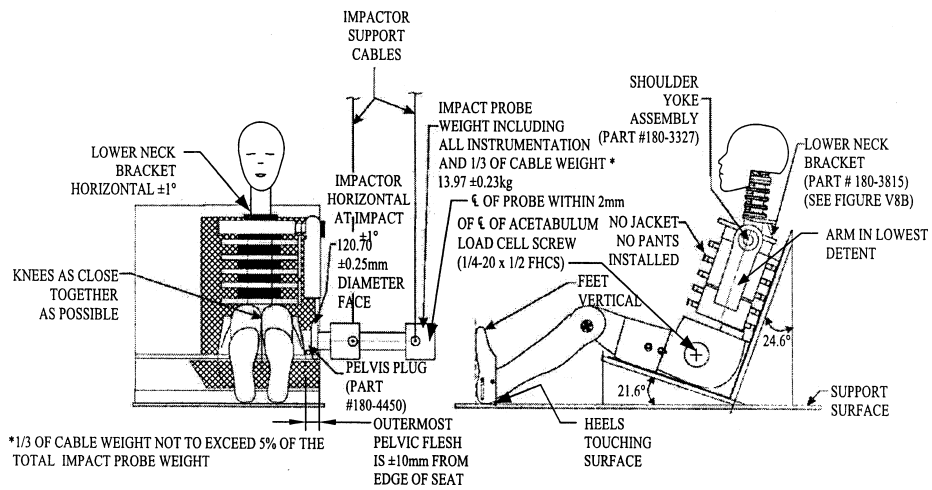
**FIGURE V7-A
ABDOMEN IMPACT**



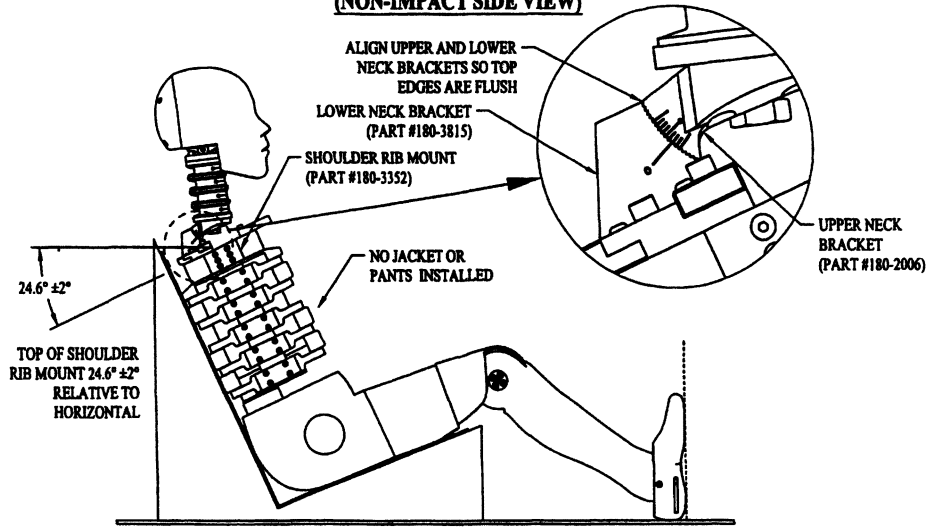
**FIGURE V7-B
ABDOMEN IMPACT
(NON-IMPACT SIDE VIEW)**



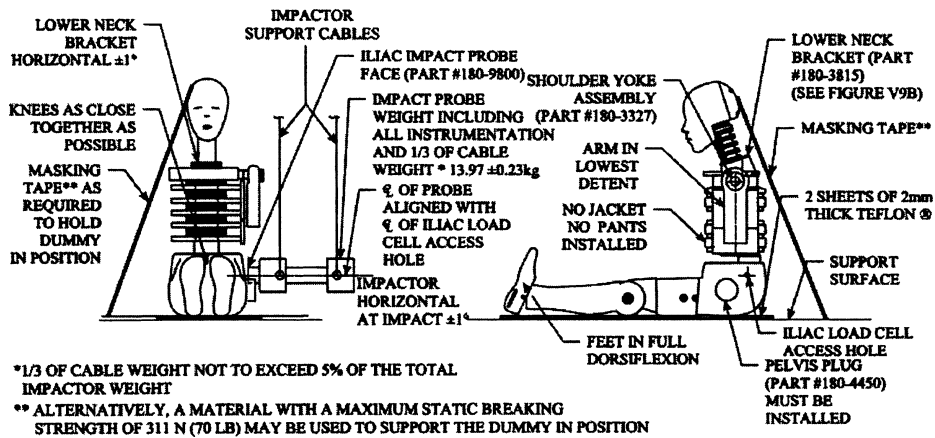
**FIGURE V8-A
ACETABULUM IMPACT**



**FIGURE V8-B
ACETABULUM IMPACT
(NON-IMPACT SIDE VIEW)**



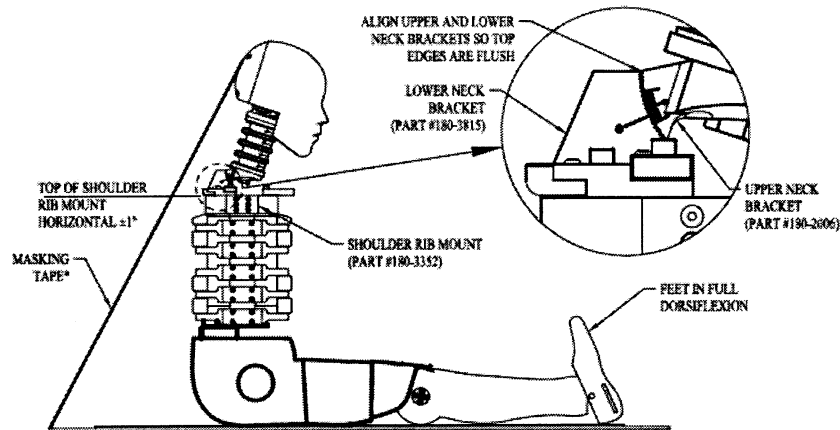
**FIGURE V9-A
ILIAC IMPACT**



*1/3 OF CABLE WEIGHT NOT TO EXCEED 5% OF THE TOTAL IMPACTOR WEIGHT

** ALTERNATIVELY, A MATERIAL WITH A MAXIMUM STATIC BREAKING STRENGTH OF 311 N (70 LB) MAY BE USED TO SUPPORT THE DUMMY IN POSITION

**FIGURE V9-B
ILIAC IMPACT
(NON-IMPACT SIDE VIEW)**



* ALTERNATIVELY, A MATERIAL WITH A MAXIMUM STATIC BREAKING STRENGTH OF 311 N (70 LB) MAY BE USED TO SUPPORT THE DUMMY IN POSITION

[71 FR 75370, Dec. 14, 2006, as amended at 74 FR 29896, June 23, 2009]

AUTHORITY: 49 U.S.C. 30102, 30103, 30116–30121, 30166; delegation of authority at 49 CFR 1.50 and 49 CFR 501.8.

SOURCE: 43 FR 60169, Dec. 26, 1978, unless otherwise noted.

PART 573—DEFECT AND NON-COMPLIANCE RESPONSIBILITY AND REPORTS

Sec.

- 573.1 Scope.
- 573.2 Purpose.
- 573.3 Application.
- 573.4 Definitions.
- 573.5 Defect and noncompliance responsibility.
- 573.6 Defect and noncompliance information report.
- 573.7 Quarterly reports.
- 573.8 Lists of purchasers, owners, dealers, distributors, lessors and lessees.
- 573.9 Address for submitting required reports and other information.
- 573.10 Reporting the sale or lease of defective or noncompliant tires.
- 573.11 Prohibition on sale or lease of new defective and noncompliant motor vehicles and items of replacement equipment.
- 573.12 Prohibition on sale or lease of new and used defective and noncompliant motor vehicle equipment.
- 573.13 Reimbursement for prenotification remedies.
- 573.14 Accelerated remedy program.

§573.1 Scope.

This part:

- (a) Sets forth the responsibilities under 49 U.S.C. 30116–30121 of manufacturers of motor vehicles and motor vehicle equipment with respect to safety-related defects and noncompliances with Federal motor vehicle safety standards in motor vehicles and items of motor vehicle equipment; and
- (b) Specifies requirements for—
 - (1) Manufacturers to maintain lists of owners, purchasers, dealers, and distributors notified of defective and non-complying motor vehicles and motor vehicle original and replacement equipment,
 - (2) Reporting to the National Highway Traffic Safety Administration (NHTSA) defects in motor vehicles and motor vehicle equipment and non-compliances with motor vehicle safety standards prescribed under part 571 of this chapter, and

(3) Providing quarterly reports on defect and noncompliance notification campaigns.

[69 FR 34959, June 23, 2004]

§ 573.2 Purposes.

The purposes of this part are:

(a) To facilitate the notification of owners of defective and noncomplying motor vehicles and items of motor vehicle equipment, and the remedy of such defects and noncompliances, by equitably apportioning the responsibility for safety-related defects and noncompliances with Federal motor vehicle safety standards among manufacturers of motor vehicles and motor vehicle equipment; and

(b) To inform NHTSA of defective and noncomplying motor vehicles and items of motor vehicle equipment, and to obtain information for NHTSA on the adequacy of manufacturers' defect and noncompliance notification campaigns, on corrective action, on owner response, and to compare the defect incidence rate among different groups of vehicles.

[67 FR 45872, July 10, 2002]

§ 573.3 Application.

(a) Except as provided in paragraphs (g), (h), and (i) of this section, this part applies to manufacturers of complete motor vehicles, incomplete motor vehicles, and motor vehicle original and replacement equipment, with respect to all vehicles and equipment that have been transported beyond the direct control of the manufacturer.

(b) In the case of a defect or non-compliance decided to exist in a motor vehicle or equipment item imported into the United States, compliance with §§ 573.6 and 573.7 by either the fabricating manufacturer or the importer of the vehicle or equipment item shall be considered compliance by both.

(c) In the case of a defect or non-compliance decided to exist in a vehicle manufactured in two or more stages, compliance with §§ 573.6 and 573.7 by either the manufacturer of the incomplete vehicle or any subsequent manufacturer of the vehicle shall be considered compliance by all manufacturers.

(d) In the case of a defect or non-compliance decided to exist in an item of replacement equipment (except tires) compliance with §§ 573.6 and 573.7 by the brand name or trademark owner shall be considered compliance by the manufacturer. Tire brand name owners are considered manufacturers (49 U.S.C. 10102(b)(1)(E)) and have the same reporting requirements as manufacturers.

(e) In the case of a defect or non-compliance decided to exist in an item of original equipment used in the vehicles of only one vehicle manufacturer, compliance with §§ 573.6 and 573.7 by either the vehicle or equipment manufacturer shall be considered compliance by both.

(f) In the case of a defect or non-compliance decided to exist in original equipment installed in the vehicles of more than one manufacturer, compliance with § 573.6 is required of the equipment manufacturer as to the equipment item, and of each vehicle manufacturer as to the vehicles in which the equipment has been installed. Compliance with § 573.7 is required of the manufacturer who is conducting the recall campaign.

(g) The provisions of § 573.10 apply to all persons.

(h) The provisions of § 573.11 apply to dealers, including retailers of motor vehicle equipment.

(i) The provisions of § 573.12 apply to all persons.

[43 FR 60169, Dec. 26, 1978, as amended at 60 FR 17268, Apr. 5, 1995; 66 FR 38162, July 23, 2001; 67 FR 19697, Apr. 23, 2002; 68 FR 18142, Apr. 15, 2003]

§ 573.4 Definitions.

For purposes of this part:

Act means 49 U.S.C. Chapter 301.

Administrator means the Administrator of the National Highway Traffic Safety Administration or his delegate.

First purchaser means first purchaser for purposes other than resale.

Leased motor vehicle means any motor vehicle that is leased to a person for a term of at least four months by a lessor who has leased five or more vehicles in the twelve months preceding the date of notification by the vehicle manufacturer of the existence of a safety-related defect or noncompliance

§573.5

with a Federal motor vehicle safety standard in the motor vehicle.

Lessee means a person who is the lessee of a leased motor vehicle as defined in this section.

Lessor means a person or entity that is the owner, as reflected on the vehicle's title, of any five or more leased vehicles (as defined in this section), as of the date of notification by the manufacturer of the existence of a safety-related defect or noncompliance with a Federal motor vehicle safety standard in one or more of the leased motor vehicles.

Original equipment means an item of motor vehicle equipment (other than a tire) that was installed in or on a motor vehicle at the time of its delivery to the first purchaser if the item of equipment was installed on or in the motor vehicle at the time of its delivery to a dealer or distributor for distribution, or was installed by the dealer or distributor with the express authorizations of the motor vehicle manufacturer.

Readable form means a form readable by the unassisted eye or readable by machine. If readable by machine, the submitting party must obtain written confirmation from the Office of Defects Investigation immediately prior to submission that the machine is readily available to NHTSA. For all similar information responses, once a manufacturer has obtained approval for the original response in that form, it will not have to obtain approval for future submissions in the same form. In addition, all coded information must be accompanied by an explanation of the codes used.

Replacement equipment means motor vehicle equipment other than original equipment as defined in this section, and tires.

[43 FR 60169, Dec. 26, 1978, as amended at 60 FR 17268, Apr. 5, 1995; 67 FR 45872, July 10, 2002]

§573.5 Defect and noncompliance responsibility.

(a) Each manufacturer of a motor vehicle shall be responsible for any safety-related defect or any noncompliance determined to exist in the vehicle or in any item of original equipment.

49 CFR Ch. V (10–1–10 Edition)

(b) Each manufacturer of an item of replacement equipment shall be responsible for any safety-related defect or any noncompliance determined to exist in the equipment.

[67 FR 45872, July 10, 2002]

§573.6 Defect and noncompliance information report.

(a) Each manufacturer shall furnish a report to the NHTSA for each defect in his vehicles or in his items of original or replacement equipment that he or the Administrator determines to be related to motor vehicle safety, and for each noncompliance with a motor vehicle safety standard in such vehicles or items of equipment which either he or the Administrator determines to exist.

(b) Each report shall be submitted not more than 5 working days after a defect in a vehicle or item of equipment has been determined to be safety related, or a noncompliance with a motor vehicle safety standard has been determined to exist. At a minimum, information required by paragraphs (1), (2) and (5) of paragraph (c) of this section shall be submitted in the initial report. The remainder of the information required by paragraph (c) of this section that is not available within the five-day period shall be submitted as it becomes available. Each manufacturer submitting new information relative to a previously submitted report shall refer to the notification campaign number when a number has been assigned by the NHTSA.

(c) Each manufacturer shall include in each report the information specified below.

(1) The manufacturer's name: The full corporate or individual name of the fabricating manufacturer and any brand name or trademark owner of the vehicle or item of equipment shall be spelled out, except that such abbreviations as "Co." or "Inc.", and their foreign equivalents, and the first and middle initials of individuals, may be used. In the case of a defect or noncompliance decided to exist in an imported vehicle or item of equipment, the agency designated by the fabricating manufacturer pursuant to 49 U.S.C. section 30164(a) shall be also stated. If the fabricating manufacturer is a corporation

that is controlled by another corporation that assumes responsibility for compliance with all requirements of this part the name of the controlling corporation may be used.

(2) Identification of the vehicles or items of motor vehicle equipment potentially containing the defect or non-compliance, including a description of the manufacturer's basis for its determination of the recall population and a description of how the vehicles or items of equipment to be recalled differ from similar vehicles or items of equipment that the manufacturer has not included in the recall.

(i) In the case of passenger cars, the identification shall be by the make, line, model year, the inclusive dates (month and year) of manufacture, and any other information necessary to describe the vehicles.

(ii) In the case of vehicles other than passenger cars, the identification shall be by body style or type, inclusive dates (month and year) of manufacture and any other information necessary to describe the vehicles, such as GVWR or class for trucks, displacement (cc) for motorcycles, and number of passengers for buses.

(iii) In the case of items of motor vehicle equipment, the identification shall be by the generic name of the component (tires, child seating systems, axles, *etc.*), part number (for tires, a range of tire identification numbers, as required by 49 CFR 574.5), size and function if applicable, the inclusive dates (month and year) of manufacture if available and any other information necessary to describe the items.

(iv) In the case of motor vehicles or items of motor vehicle equipment in which the component that contains the defect or noncompliance was manufactured by a different manufacturer from the reporting manufacturer, the reporting manufacturer shall identify the component and, if known, the component's country of origin (*i.e.* final place of manufacture or assembly), the manufacturer and/or assembler of the component by name, business address, and business telephone number. If the reporting manufacturer does not know the identity of the manufacturer of the component, it shall identify the entity

from which it was obtained. If at the time of submission of the initial report, the reporting manufacturer does not know the country of origin of the component, the manufacturer shall ascertain the country of origin and submit a supplemental report with that information once it becomes available.

(v) In the case of items of motor vehicle equipment, the manufacturer of the equipment shall identify by name, business address, and business telephone number every manufacturer that purchases the defective or noncomplying component for use or installation in new motor vehicles or new items of motor vehicle equipment.

(3) The total number of vehicles or items of equipment potentially containing the defect or noncompliance, and where available the number of vehicles or items of equipment in each group identified pursuant to paragraph (c)(2) of this section.

(4) The percentage of vehicles or items of equipment specified pursuant to paragraph (c)(2) of this section estimated to actually contain the defect or noncompliance.

(5) A description of the defect or non-compliance, including both a brief summary and a detailed description, with graphic aids as necessary, of the nature and physical location (if applicable) of the defect or noncompliance.

(6) In the case of a defect, a chronology of all principal events that were the basis for the determination that the defect related to motor vehicle safety, including a summary of all warranty claims, field or service reports, and other information, with their dates of receipt.

(7) In the case of a noncompliance, the test results and other information that the manufacturer considered in determining the existence of the non-compliance. The manufacturer shall identify the date of each test and observation that indicated that a non-compliance might or did exist.

(8)(i) A description of the manufacturer's program for remedying the defect or noncompliance. This program shall include a plan for reimbursing an owner or purchaser who incurred costs

§ 573.6

49 CFR Ch. V (10–1–10 Edition)

to obtain a remedy for the problem addressed by the recall within a reasonable time in advance of the manufacturer's notification of owners, purchasers and dealers, in accordance with § 573.13 of this part. A manufacturer's plan may incorporate by reference a general reimbursement plan it previously submitted to NHTSA, together with information specific to the individual recall. Information required by § 573.13 that is not in a general reimbursement plan shall be submitted in the manufacturer's report to NHTSA under this section. If a manufacturer submits one or more general reimbursement plans, the manufacturer shall update each plan every two years, in accordance with § 573.13. The manufacturer's remedy program and reimbursement plans will be available for inspection by the public at NHTSA headquarters.

(ii) The estimated date(s) on which it will begin sending notifications to owners, and to dealers and distributors, that there is a safety-related defect or noncompliance and that a remedy without charge will be available to owners, and the estimated date(s) on which it will complete such notifications (if different from the beginning date). If a manufacturer subsequently becomes aware that either the beginning or the completion dates reported to the agency for any of the notifications will be delayed by more than two weeks, it shall promptly advise the agency of the delay and the reasons therefore, and furnish a revised estimate.

(iii) If a manufacturer intends to file a petition for an exemption from the recall requirements of the Act on the basis that a defect or noncompliance is inconsequential as it relates to motor vehicle safety, it shall notify NHTSA of that intention in its report to NHTSA of the defect or noncompliance under this section. If such a petition is filed and subsequently denied, the manufacturer shall provide the information required by paragraph (c)(8)(ii) of this section within five Federal government business days from the date the petition denial is published in the FEDERAL REGISTER.

(iv) If a manufacturer advises NHTSA that it intends to file such a petition

for exemption from the notification and remedy requirements on the grounds that the defect or noncompliance is inconsequential as it relates to motor vehicle safety, and does not do so within the 30-day period established by 49 CFR 556.4(c), the manufacturer must submit the information required by paragraph (c)(8)(ii) of this section no later than the end of that 30-day period.

(9) In the case of a remedy program involving the replacement of tires, the manufacturer's program for remedying the defect or noncompliance shall:

(i) Address how the manufacturer will assure that the entities replacing the tires are aware of the legal requirements related to recalls of tires established by 49 U.S.C. Chapter 301 and regulations thereunder. At a minimum, the manufacturer shall notify its owned stores and/or distributors, as well as all independent outlets that are authorized to replace the tires that are the subject of the recall, annually or for each individual recall that the manufacturer conducts, about the ban on the sale of new defective or non-compliant tires (49 CFR 573.11); the prohibition on the sale of new and used defective and noncompliant tires (49 CFR 573.12); and the duty to notify NHTSA of any sale of a new or used recalled tire for use on a motor vehicle (49 CFR 573.10). For tire outlets that are manufacturer-owned or otherwise subject to the control of the manufacturer, the manufacturer shall also provide directions to comply with these statutory provisions and the regulations thereunder.

(ii) Address how the manufacturer will prevent, to the extent reasonably within its control, the recalled tires from being resold for installation on a motor vehicle. At a minimum, the manufacturer shall include the following information, to be furnished to each tire outlet that it owns, or that is authorized to replace tires that are recalled, either annually or for each individual recall the manufacturer conducts:

(A) Written directions to manufacturer-owned and other manufacturer-controlled outlets to alter the recalled tires permanently so that they cannot be used on vehicles. These shall include

instructions on the means to render recalled tires unsuitable for resale for installation on motor vehicles and instructions to perform the incapacitation of each recalled tire, with the exception of any tires that are returned to the manufacturer pursuant to a testing program, within 24 hours of receipt of the recalled tire at the outlet. If the manufacturer has a testing program for recalled tires, these directions shall also include criteria for selecting recalled tires for testing and instructions for labeling those tires and returning them promptly to the manufacturer for testing.

(B) Written guidance to all other outlets which are authorized to replace the recalled tires on how to alter the recalled tires promptly and permanently so that they cannot be used on vehicles.

(C) A requirement that manufacturer-owned and other manufacturer-controlled outlets report to the manufacturer, either on a monthly basis or within 30 days of the deviation, the number of recalled tires removed from vehicles by the outlet that have not been rendered unsuitable for resale for installation on a motor vehicle within the specified time frame (other than those returned for testing) and describe any such failure to act in accordance with the manufacturer's plan;

(iii) Address how the manufacturer will limit, to the extent reasonably within its control, the disposal of the recalled tires in landfills and, instead, channel them into a category of positive reuse (shredding, crumbling, recycling, and recovery) or another alternative beneficial non-vehicular use. At a minimum, the manufacturer shall include the following information, to be furnished to each tire outlet that it owns or that is authorized to replace tires that are recalled, either annually or for each individual recall that the manufacturer conducts:

(A)(I) Written directions that require manufacturer-owned and other manufacturer-controlled outlets either:

(i) To ship recalled tires to one or more locations designated by the manufacturer as part of the program or allow the manufacturer to collect and dispose of the recalled tires; or

(ii) To ship recalled tires to a location of their own choosing, provided that they comply with applicable state and local laws and regulations regarding disposal of tires.

(2) Under option (c)(9)(iii)(A)(I)(ii) of this section, the directions must also include further direction and guidance on how to limit the disposal of recalled tires in landfills and, instead, channel them into a category of positive reuse (shredding, crumbling, recycling, and recovery) or another alternative beneficial non-vehicular use.

(B)(I) Written guidance that authorizes all other outlets that are authorized to replace the recalled tires either:

(i) To ship recalled tires to one or more locations designated by the manufacturer or allow the manufacturer to collect and dispose of the recalled tires; or

(ii) To ship recalled tires to a location of their own choosing, provided that they comply with applicable state and local laws and regulations regarding disposal of tires.

(2) Under option (c)(9)(iii)(B)(I)(ii) of this section, the manufacturer must also include further guidance on how to limit the disposal of recalled tires in landfills and, instead, channel them into a category of positive reuse (shredding, crumbling, recycling, and recovery) or another alternative beneficial non-vehicular use.

(C) A requirement that manufacturer-owned and other manufacturer-controlled outlets report to the manufacturer, on a monthly basis or within 30 days of the deviation, the number of recalled tires disposed of in violation of applicable state and local laws and regulations, and describe any such failure to act in accordance with the manufacturer's plan; and

(D) A description of the manufacturer's program for disposing of the recalled tires that are returned to the manufacturer or collected by the manufacturer from the retail outlets, including, at a minimum, statements that the returned tires will be disposed of in compliance with applicable state and local laws and regulations regarding disposal of tires, and will be channeled, insofar as possible, into a category of positive reuse (shredding, crumbling, recycling and recovery) or

§573.7

another alternative beneficial non-vehicular use, instead of being disposed of in landfills.

(iv) To the extent that the manufacturer wishes to limit the frequency of shipments of recalled tires, it must specify both a minimum time period and a minimum weight for the shipments and provide that shipments may be made at whichever minimum occurs first.

(v) Written directions required under this paragraph to be furnished to a manufacturer-owned or controlled outlet shall be sent to the person in charge of each outlet by first-class mail or by electronic means, such as FAX transmissions or e-mail, with further instructions to notify all employees of the outlet who are involved with removal, rendering unsuitable for use, or disposition of recalled tires of the applicable requirements and procedures.

(vi) Manufacturers must implement the plans for disposition of recalled tires that they file with NHTSA pursuant to this paragraph. The failure of a manufacturer to implement its plan in accordance with its terms constitutes a violation of the Safety Act.

(10) A representative copy of all notices, bulletins, and other communications that relate directly to the defect or noncompliance and are sent to more than one manufacturer, distributor, dealer or purchaser. These copies shall be submitted to NHTSA's Recall Management Division (NVS-215) (RMD), not later than 5 days after they are initially sent to manufacturers, distributors, dealers, or purchasers. Submission shall be made by any means, including those means identified in §573.9 of this part, which permits the manufacturer to verify promptly that the copy was in fact received by RMD and the date it was received by RMD.

(11) The manufacturer's campaign number, if not identical to the identification number assigned by NHTSA.

[43 FR 60169, Dec. 26, 1978, as amended at 44 FR 20437, Apr. 5, 1979; 48 FR 44081, Sept. 27, 1983; 60 FR 17268, Apr. 5, 1995; 61 FR 278, Jan. 4, 1996. Redesignated at 67 FR 45872, July 10, 2002, as amended at 67 FR 64063, Oct. 17, 2002; 69 FR 34959, June 23, 2004; 69 FR 50084, Aug. 13, 2004; 70 FR 38814, July 6, 2005; 72 FR 32016, June 11, 2007; 74 FR 47757, Sept. 17, 2009]

49 CFR Ch. V (10-1-10 Edition)

§573.7 Quarterly reports.

(a) Each manufacturer who is conducting a defect or noncompliance notification campaign to manufacturers, distributors, dealers, or owners shall submit to NHTSA a report in accordance with paragraphs (b), (c), and (d) of this section. Unless otherwise directed by the NHTSA, the information specified in paragraphs (b)(1) through (5) of this section shall be included in the quarterly report, with respect to each notification campaign, for each of six consecutive quarters beginning with the quarter in which the campaign was initiated (i.e., the date of initial mailing of the defect or noncompliance notification to owners) or corrective action has been completed on all defective or noncomplying vehicles or items of replacement equipment involved in the campaign, whichever occurs first.

(b) Each report shall include the following information identified by and in the order of the subparagraph headings of this paragraph.

(1) The notification campaign number assigned by NHTSA.

(2) The date notification began and the date completed.

(3) The number of vehicles or items of equipment involved in the notification campaign.

(4) The number of vehicles and equipment items which have been inspected and repaired and the number of vehicles and equipment items inspected and determined not to need repair.

(5) The number of vehicles or items of equipment determined to be unreachable for inspection due to export, theft, scrapping, failure to receive notification, or other reasons (specify). The number of vehicles or items or equipment in each category shall be specified.

(6) In reports by equipment manufacturers, the number of items of equipment repaired and/or returned by dealers, other retailers, and distributors to the manufacturer prior to their first sale to the public.

(7) For all recalls that involve the replacement of tires, the manufacturer shall provide:

(i) The aggregate number of recalled tires that the manufacturer becomes aware have not been rendered unsuitable for resale for installation on a

motor vehicle in accordance with the manufacturer's plan provided to NHTSA pursuant to § 573.6(c)(9);

(ii) The aggregate number of recalled tires that the manufacturer becomes aware have been disposed of in violation of applicable state and local laws and regulations; and

(iii) A description of any failure of a tire outlet to act in accordance with the directions in the manufacturer's plan, including an identification of the outlet(s) in question.

(c) Information supplied in response to the paragraphs (b)(4) and (5) of this section shall be cumulative totals.

(d) The reports required by this section shall be submitted in accordance with the following schedule, except that if the due date specified below falls on a Saturday, Sunday or Federal holiday, the report shall be submitted on the next day that is a business day for the Federal government:

(1) For the first calendar quarter (January 1 through March 31), on or before April 30;

(2) For the second calendar quarter (April 1 through June 30), on or before July 30;

(3) For the third calendar quarter (July 1 through September 30), on or before October 30; and

(4) For the fourth calendar quarter (October 1 through December 31), on or before January 30.

[51 FR 398, Jan. 6, 1986, as amended at 60 FR 17269, Apr. 5, 1995. Redesignated at 67 FR 45872, July 10, 2002, as amended at 69 FR 50085, Aug. 13, 2004]

§ 573.8 Lists of purchasers, owners, dealers, distributors, lessors, and lessees.

(a) Each manufacturer of motor vehicles shall maintain, in a form suitable for inspection such as computer information storage devices or card files, a list of the names and addresses of registered owners, as determined through State motor vehicle registration records or other sources or the most recent purchasers where the registered owners are unknown, for all vehicles involved in a defect or noncompliance notification campaign initiated after the effective date of this part. The list shall include the vehicle identification number for each vehicle and the status

of remedy with respect to each vehicle, updated as of the end of each quarterly reporting period specified in § 573.7. Each vehicle manufacturer shall also maintain such a list of the names and addresses of all dealers and distributors to which a defect or noncompliance notification was sent. Each list shall be retained for 5 years, beginning with the date on which the defect or noncompliance information report required by § 573.6 is initially submitted to NHTSA.

(b) Each manufacturer (including brand name owners) of tires shall maintain, in a form suitable for inspection such as computer information storage devices or card files, a list of the names and addresses of the first purchasers of his tires for all tires involved in a defect or noncompliance notification campaign initiated after the effective date of this part. The list shall include the tire identification number of all tires and shall show the status of remedy with respect to each owner involved in each notification campaign, updated as of the end of each quarterly reporting period specified in § 573.6. Each list shall be retained, beginning with the date on which the defect information report is initially submitted to the NHTSA, for 3 years.

(c) For each item of equipment involved in a defect or noncompliance notification campaign initiated after the effective date of this part, each manufacturer of motor vehicle equipment other than tires shall maintain, in a form suitable for inspection, such as computer information storage devices or card files, a list of the names and addresses of each distributor and dealer of such manufacturer, each motor vehicle or motor vehicle equipment manufacturer and most recent purchaser known to the manufacturer to whom a potentially defective or non-complying item of equipment has been sold and to whom notification is sent, the number of such items sold to each, and the date of shipment. The list shall show as far as is practicable the number of items remedied or returned to the manufacturer and the dates of such remedy or return. Each list shall be retained, beginning with the date on which the defect report required by

§ 573.9

§ 573.5 is initially submitted to the NHTSA, for 5 years.

(d) Each lessor of leased motor vehicles that receives a notification from the manufacturer of such vehicles that the vehicle contains a safety-related defect or fails to comply with a Federal motor vehicle safety standard shall maintain, in a form suitable for inspection, such as computer information storage devices or card files, a list of the names and addresses of all lessees to which the lessor has provided notification of a defect or noncompliance pursuant to 49 CFR 577.5(h). The list shall also include the make, model, model year, and vehicle identification number of each such leased vehicle, and the date on which the lessor mailed notification of the defect or noncompliance to the lessee. The information required by this paragraph must be retained by the lessor for one calendar year from the date the vehicle lease expires.

[43 FR 60169, Dec. 26, 1978, as amended at 44 FR 20437, Apr. 5, 1979; 60 FR 17269, Apr. 5, 1995; 61 FR 278, Jan. 4, 1996. Redesignated at 67 FR 45872, July 10, 2002; 69 FR 34959, June 23, 2004]

§ 573.9 Address for submitting required reports and other information.

All submissions, except as otherwise required by this part, shall be addressed to the Associate Administrator for Enforcement, National Highway Traffic Safety Administration, Attention: Recall Management Division (NVS-215), 1200 New Jersey Avenue, SE., Washington, DC 20590. These submissions may be submitted as an attachment to an e-mail message to *RMD.ODI@dot.gov* in a portable document format (.pdf). Whether or not they are also submitted electronically, defect or noncompliance reports required by section 573.6 of this part must be submitted by certified mail in accordance with 49 U.S.C. 30118(c).

[72 FR 32016, June 11, 2007]

§ 573.10 Reporting the sale or lease of defective or noncompliant tires.

(a) *Reporting requirement.* Subject to paragraph (b) of this section, any person who knowingly and willfully sells or leases for use on a motor vehicle a

49 CFR Ch. V (10–1–10 Edition)

defective tire or a tire that is not compliant with an applicable tire safety standard with actual knowledge that the manufacturer of such tire has notified its dealers of such defect or noncompliance as required under 49 U.S.C. 30118(c) or as required by an order under 49 U.S.C. 30118(b) must report that sale or lease to the Associate Administrator for Enforcement, NHTSA, 1200 New Jersey Ave., SE., Washington, DC 20590.

(b) *Exclusions from reporting requirement.* Paragraph (a) of this section is not applicable where, before delivery under a sale or lease of a tire:

(1) The defect or noncompliance of the tire is remedied as required under 49 U.S.C. 30120; or

(2) Notification of the defect or noncompliance is required by an order under 49 U.S.C. 30118(b), but enforcement of the order is restrained or the order is set aside in a civil action to which 49 U.S.C. 30121(d) applies.

(c) *Contents of report; requirement of signature.* (1) A report submitted pursuant to paragraph (a) of this section must contain the following information, where that information is available to the person selling or leasing the defective or noncompliant tire:

(i) A statement that the report is being submitted pursuant to 49 CFR 573.10(a) (sale or lease of defective or noncompliant tires);

(ii) The name, address and phone number of the person who purchased or leased the tire;

(iii) The name of the manufacturer of the tire;

(iv) The tire's brand name, model name, and size;

(v) The tire's DOT identification number;

(vi) The date of the sale or lease; and

(vii) The name, address, and telephone number of the seller or lessor.

(2) Each report must be dated and signed, with the name of the person signing the report legibly printed or typed below the signature.

(d) Reports required to be submitted pursuant to this section must be submitted no more than that five working days after a person to whom a tire covered by this section has been sold or leased has taken possession of that tire. Submissions must be made by any

means which permits the sender to verify promptly that the report was in fact received by NHTSA and the day it was received by NHTSA.

[65 FR 81413, Dec. 26, 2000, as amended at 72 FR 32016, June 11, 2007]

§ 573.11 Prohibition on sale or lease of new defective and noncompliant motor vehicles and items of replacement equipment.

(a) If notification is required by an order under 49 U.S.C. 30118(b) or is required under 49 U.S.C. 30118(c) and the manufacturer has provided to a dealer (including retailers of motor vehicle equipment) notification about a new motor vehicle or new item of replacement equipment in the dealer's possession, including actual and constructive possession, at the time of notification that contains a defect related to motor vehicle safety or does not comply with an applicable motor vehicle safety standard issued under 49 CFR part 571, the dealer may sell or lease the motor vehicle or item of replacement equipment only if:

(1) The defect or noncompliance is remedied as required by 49 U.S.C. 30120 before delivery under the sale or lease; or

(2) When the notification is required by an order under 49 U.S.C. 30118(b), enforcement of the order is restrained or the order is set aside in a civil action to which 49 U.S.C. 30121(d) applies.

(b) Paragraph (a) of this section does not prohibit a dealer from offering the vehicle or equipment for sale or lease, provided that the dealer does not sell or lease it.

[67 FR 19697, Apr. 23, 2002]

§ 573.12 Prohibition on sale or lease of new and used defective and non-compliant motor vehicle equipment.

(a) Subject to § 573.12(b), no person may sell or lease any new or used item of motor vehicle equipment (including a tire) as defined by 49 U.S.C. 30102(a)(7), for installation on a motor vehicle, that is the subject of a decision under 49 U.S.C. 30118(b) or a notice required under 49 U.S.C. 30118(c), in a condition that it may be reasonably used for its original purpose.

(b) Paragraph (a) of this section is not applicable where:

(1) The defect or noncompliance is remedied as required under 49 U.S.C. 30120 before delivery under the sale or lease;

(2) Notification of the defect or non-compliance is required by an order under 49 U.S.C. 30118(b), but enforcement of the order is restrained or the order is set aside in a civil action to which 49 U.S.C. 30121(d) applies.

[67 FR 19698, Apr. 23, 2002]

§ 573.13 Reimbursement for pre-notification remedies.

(a) Pursuant to 49 U.S.C. 30120(d) and § 573.6(c)(8)(i) of this part, this section specifies requirements for a manufacturer's plan (including general reimbursement plans submitted pursuant to § 573.6(c)(8)(i)) to reimburse owners and purchasers for costs incurred for remedies in advance of the manufacturer's notification of safety-related defects and noncompliance with Federal motor vehicle safety standards under subsection (b) or (c) of 49 U.S.C. 30118.

(b) Definitions. The following definitions apply to this section:

(1) *Booster seat* means either a backless child restraint system or a belt-positioning seat.

(2) *Claimant* means a person who seeks reimbursement for the costs of a pre-notification remedy for which he or she paid.

(3) *Pre-notification remedy* means a remedy that is performed on a motor vehicle or item of replacement equipment for a problem subsequently addressed by a notification under subsection (b) or (c) of 49 U.S.C. 30118 and that is obtained during the period for reimbursement specified in paragraph (c) of this section.

(4) *Other child restraint system* means all child restraint systems as defined in 49 CFR 571.213 S4 not included within the categories of rear-facing infant seat or booster seat.

(5) *Rear-facing infant seat* means a child restraint system that is designed to position a child to face only in the direction opposite to the normal direction of travel of the motor vehicle.

(6) *Warranty* means a warranty as defined in § 579.4(c) of this chapter.

(c) The manufacturer's plan shall specify a period for reimbursement, as follows:

§573.13

49 CFR Ch. V (10–1–10 Edition)

(1) The beginning date shall be no later than a date based on the underlying basis for the recall determined as follows:

(i) For a noncompliance with a Federal motor vehicle safety standard, the date shall be the date of the first test or observation by either NHTSA or the manufacturer indicating that a noncompliance may exist.

(ii) For a safety-related defect that is determined to exist following the opening of an Engineering Analysis (EA) by NHTSA's Office of Defects Investigation (ODI), the date shall be the date the EA was opened, or one year before the date of the manufacturer's notification to NHTSA pursuant to §573.6 of this part, whichever is earlier.

(iii) For a safety-related defect that is determined to exist in the absence of the opening of an EA, the date shall be one year before the date of the manufacturer's notification to NHTSA pursuant to §573.6 of this part.

(2) The ending date shall be no earlier than:

(i) For motor vehicles, 10 calendar days after the date on which the manufacturer mailed the last of its notifications to owners pursuant to part 577 of this chapter.

(ii) For replacement equipment, 10 calendar days after the date on which the manufacturer mailed the last of its notifications to owners pursuant to part 577 of this chapter (where applicable) or 30 days after the conclusion of the manufacturer's initial efforts to provide public notice of the existence of the defect or noncompliance pursuant to §577.7, whichever is later.

(d) The manufacturer's plan shall provide for reimbursement of costs for pre-notification remedies, subject to the conditions established in the plan. The following conditions and no others may be established in the plan.

(1) The plan may exclude reimbursement for costs incurred within the period during which the manufacturer's original or extended warranty would have provided for a free repair of the problem addressed by the recall, without any payment by the consumer unless a franchised dealer or authorized representative of the manufacturer denied warranty coverage or the repair made under warranty did not remedy

the problem addressed by the recall. The exclusion based on an extended warranty may be applied only when the manufacturer provided written notice of the terms of the extended warranty to owners.

(2)(i) For a motor vehicle, the plan may exclude reimbursement:

(A) If the pre-notification remedy was not of the same type (repair, replacement, or refund of purchase price) as the recall remedy;

(B) If the pre-notification remedy did not address the defect or noncompliance that led to the recall or a manifestation of the defect or noncompliance; or

(C) If the pre-notification remedy was not reasonably necessary to correct the defect or noncompliance that led to the recall or a manifestation of the defect or noncompliance.

(ii) However, the plan may not require that the pre-notification remedy be identical to the remedy elected by the manufacturer pursuant to 49 U.S.C. 30120(a)(1)(A).

(3)(i) For replacement equipment, the plan may exclude reimbursement:

(A) If the pre-notification remedy did not address the defect or noncompliance that led to the recall or a manifestation of the defect or noncompliance;

(B) If the pre-notification remedy was not reasonably necessary to correct the defect or noncompliance that led to the recall or a manifestation of the defect and noncompliance; or

(C) In the case of a child restraint system that was replaced, if the replacement child restraint is not the same type (*i.e.*, rear-facing infant seat, booster seat, or other child restraint system) as the restraint that was the subject of the recall.

(ii) However, the plan may not require that the pre-notification remedy be identical to the remedy elected by the manufacturer pursuant to 49 U.S.C. 30120(a)(1)(B).

(4) The plan may exclude reimbursement if the claimant did not submit adequate documentation to the manufacturer at an address or location designated pursuant to §573.13(f). The plan may require, at most, that the following documentation be submitted:

(i) Name and mailing address of the claimant;

(ii) Identification of the product that was recalled:

(A) For motor vehicles, the vehicle make, model, model year, and vehicle identification number of the vehicle;

(B) For replacement equipment other than child restraint systems and tires, a description of the equipment, including model and size as appropriate;

(C) For child restraint systems, a description of the restraint, including the type (rear-facing infant seat, booster seat, or other child restraint system) and the model; or

(D) For tires, the model and size;

(iii) Identification of the recall (either the NHTSA recall number or the manufacturer's recall number);

(iv) Identification of the owner or purchaser of the recalled motor vehicle or replacement equipment at the time that the pre-notification remedy was obtained;

(v) A receipt for the pre-notification remedy, which may be an original or copy:

(A) If the reimbursement sought is for a repair, the manufacturer may require that the receipt indicate that the repair addressed the defect or non-compliance that led to the recall or a manifestation of the defect or non-compliance, and state the total amount paid for the repair of that problem. Itemization of a receipt of the amount for parts, labor, other costs and taxes, may not be required unless it is unclear on the face of the receipt that the repair for which reimbursement is sought addressed only the pre-notification remedy relating to the pertinent defect or noncompliance or manifestation thereof.

(B) If the reimbursement sought is for the replacement of a vehicle part or an item of replacement equipment, the manufacturer may require that the receipt identify the item and state the total amount paid for the item that replaced the defective or noncompliant item;

(vi) In the case of items of replacement equipment that were replaced, documentation that the claimant or a relative thereof (with relationship stated) owned the recalled item. Such documentation could consist of:

(A) An invoice or receipt showing purchase of the recalled item of replacement equipment;

(B) If the claimant sent a registration card for a recalled child restraint system or tire to the manufacturer, a statement to that effect;

(C) A copy of the registration card for the recalled child restraint system or tire; or

(D) Documentation demonstrating that the claimant had replaced a recalled tire that was on a vehicle that he, she, or a relative owned; and

(vii) If the pre-notification remedy was obtained at a time when the vehicle or equipment could have been repaired or replaced at no charge under a manufacturer's original or extended warranty program, documentation indicating that the manufacturer's dealer or authorized facility either refused to remedy the problem addressed by the recall under the warranty or that the warranty repair did not correct the problem addressed by the recall.

(e) The manufacturer's plan shall specify the amount of costs to be reimbursed for a pre-notification remedy.

(1) For motor vehicles:

(i) The amount of reimbursement shall not be less than the lesser of:

(A) The amount paid by the owner for the remedy, or

(B) The cost of parts for the remedy, plus associated labor at local labor rates, miscellaneous fees such as disposal of waste, and taxes. Costs for parts may be limited to the manufacturer's list retail price for authorized parts.

(ii) Any associated costs, including, but not limited to, taxes or disposal of wastes, may not be limited.

(2) For replacement equipment:

(i) The amount of reimbursement ordinarily would be the amount paid by the owner for the replacement item.

(ii) In cases in which the owner purchased a brand or model different from the item of motor vehicle equipment that was the subject of the recall, the manufacturer may limit the amount of reimbursement to the retail list price of the defective or noncompliant item that was replaced, plus taxes.

(iii) If the item of motor vehicle equipment was repaired, the provisions

§573.14

49 CFR Ch. V (10–1–10 Edition)

of paragraph (e)(1) of this section apply.

(f) The manufacturer's plan shall identify an address to which claimants may mail reimbursement claims and may identify franchised dealer(s) and authorized facilities to which claims for reimbursement may be submitted directly.

(g) The manufacturer (either directly or through its designated dealer or facility) shall act upon requests for reimbursement as follows:

(1) The manufacturer shall act upon a claim for reimbursement within 60 days of its receipt. If the manufacturer denies the claim, the manufacturer must send a notice to the claimant within 60 days of receipt of the claim that includes a clear, concise statement of the reasons for the denial.

(2) If a claim for reimbursement is incomplete when originally submitted, the manufacturer shall advise the claimant within 60 days of receipt of the claim of the documentation that is needed and offer an opportunity to resubmit the claim with complete documentation.

(h) Reimbursement shall be in the form of a check or cash from the manufacturer or a designated dealer or facility.

(i) The manufacturer shall make its reimbursement plan available to the public upon request.

(j) Any disputes over the denial in whole or in part of a claim for reimbursement shall be resolved between the claimant and the manufacturer. NHTSA will not mediate or resolve any disputes regarding eligibility for, or the amount of, reimbursement.

(k) Each manufacturer shall implement each plan for reimbursement in accordance with this section and the terms of the plan.

(l) Nothing in this section requires that a manufacturer provide reimbursement in connection with a fraudulent claim for reimbursement.

(m) A manufacturer's plan may provide that it will not apply to recalls based solely on noncompliant or defective labels.

(n) The requirement that reimbursement for a pre-notification remedy be provided to an owner does not apply if, in the case of a motor vehicle or re-

placement equipment other than a tire, it was bought by the first purchaser more than 10 calendar years before notice is given under 49 U.S.C. 30118(c) or an order is issued under section 49 U.S.C. 30118(b). In the case of a tire, this period shall be 5 calendar years.

[67 FR 64063, Oct. 17, 2002]

§573.14 Accelerated remedy program.

(a) An accelerated remedy program is one in which the manufacturer expands the sources of replacement parts needed to remedy the defect or noncompliance, or expands the number of authorized repair facilities beyond those facilities that usually and customarily provide remedy work for the manufacturer, or both.

(b) The Administrator may require a manufacturer to accelerate its remedy program if:

(1) The Administrator finds that there is a risk of serious injury or death if the remedy program is not accelerated;

(2) The Administrator finds that acceleration of the remedy program can be reasonably achieved by expanding the sources of replacement parts, expanding the number of authorized repair facilities, or both; and

(3) The Administrator determines that the manufacturer's remedy program is not likely to be capable of completion within a reasonable time.

(c) The Administrator, in deciding whether to require the manufacturer to accelerate a remedy program and what to require the manufacturer to do, will consult with the manufacturer and may consider a wide range of information, including, but not limited to, the following: the manufacturer's initial or revised report submitted under §573.6(c), information from the manufacturer, information from other manufacturers and suppliers, information from any source related to the availability and implementation of the remedy, and the seriousness of the risk of injury or death associated with the defect or noncompliance.

(d) As required by the Administrator, an accelerated remedy program shall include the manner of acceleration (expansion of the sources of replacement parts, expansion of the number of authorized repair facilities, or both), may

require submission of a plan, may identify the parts to be provided and/or the sources of those parts, may require the manufacturer to notify the agency and owners about any differences among different sources or brands of parts, may require the manufacturer to identify additional authorized repair facilities, and may specify additional owner notifications related to the program. The Administrator may also require the manufacturer to include a program to provide reimbursement to owners who incur costs to obtain the accelerated remedy.

(e) Under an accelerated remedy program, the remedy that is provided shall be equivalent to the remedy that would have been provided if the manufacturer's remedy program had not been accelerated. The replacement parts used to remedy the defect or noncompliance shall be reasonably equivalent to those that would have been used if the remedy program were not accelerated. The service procedures shall be reasonably equivalent. In the case of tires, all replacement tires shall be the same size and type as the defective or noncompliant tire, shall be suitable for use on the owner's vehicle, shall have the same or higher load index and speed rating, and, for passenger car tires, shall have the same or better rating in each of the three categories enumerated in the Uniform Tire Quality Grading System. See 49 CFR 575.104. In the case of child restraints systems, all replacements shall be of the same type (e.g., rear-facing infant seats with a base, rear-facing infant seats without a base, convertible seats (designed for use in both rear- and forward-facing modes), forward-facing only seats, high back booster seats with a five-point harness, and belt positioning booster seats) and the same overall quality.

(f) In those instances where the accelerated remedy program provides that an owner may obtain the remedy from a source other than the manufacturer or its dealers or authorized facilities by paying for the remedy and/or its installation, the manufacturer shall reimburse the owner for the cost of obtaining the remedy as specified on paragraphs (f)(1) through (f)(3) of this section. Under these circumstances, the accelerated remedy program shall

include, to the extent required by the Administrator:

(1) A description of the remedy and costs that are eligible for reimbursement, including identification of the equipment and/or parts and labor for which reimbursement is available;

(2) Identification, with specificity or as a class, of the alternative repair facilities at which reimbursable repairs may be performed, including an explanation of how to arrange for service at those facilities; and

(3) Other provisions assuring appropriate reimbursement that are consistent with those set forth in §573.13, including, but not limited to, provisions regarding the procedures and needed documentation for making a claim for reimbursement, the amount of costs to be reimbursed, the office to which claims for reimbursement shall be submitted, the requirements on manufacturers for acting on claims for reimbursement, and the methods by which owners can obtain information about the program.

(g) In response to a manufacturer's request, the Administrator may authorize a manufacturer to terminate its accelerated remedy program if the Administrator concludes that the manufacturer can meet all future demands for the remedy through its own sources in a prompt manner. If required by the Administrator, the manufacturer shall provide notice of the termination of the program to all owners of unremedied vehicles and equipment at least 30 days in advance of the termination date, in a form approved by the Administrator.

(h) Each manufacturer shall implement any accelerated remedy program required by the Administrator according to the terms of that program.

[67 FR 72392, Dec. 5, 2002]

PART 574—TIRE IDENTIFICATION AND RECORDKEEPING

- Sec.
- 574.1 Scope.
- 574.2 Purpose.
- 574.3 Definitions.
- 574.4 Applicability.
- 574.5 Tire identification requirements.
- 574.6 Identification mark.

§ 574.1

574.7 Information requirements—new tire manufacturers, new tire brand name owners.

574.8 Information requirements—tire distributors and dealers.

574.9 Requirements for motor vehicle dealers.

574.10 Requirements for motor vehicle manufacturers.

AUTHORITY: 49 U.S.C. 322, 30111, 30115, 30117, and 30166; delegation of authority at 49 CFR 1.50.

EDITORIAL NOTE: An interpretation of manufacturer's designee issued by NHTSA and published at 36 FR 9780, May 28, 1971, provides as follows:

“A request for an interpretation has been received from the Rubber Manufacturers Association asking that it be made clear that, under the Tire Identification and Record-keeping Regulation (part 574), particularly §§ 574.7 and 574.8, only the tire manufacturer, brand name owner, or retreader may designate a third party to provide the necessary recording forms or to maintain the records required by the regulation.

“Another person has requested an interpretation concerning the questions whether: (1) A tire manufacturer, brand name owner or retreader may designate one or more persons to be its designee for the purpose of maintaining the information, (2) an independent distributor or dealer may select a designee for the retention of the manufacturer's records, provided the manufacturer approves the designation, and (3) the independent distributor or dealer may seek administrative relief in the event he believes the information retained by the manufacturer is being used to his detriment.

“Under section 113(f) of the National Traffic and Motor Vehicle Safety Act (15 U.S.C. 1402(f) and part 574, it is the tire manufacturer who has the ultimate responsibility for maintaining the records of first purchasers. Therefore, it is the tire manufacturer or his designee who must maintain these records. The term *designee*, as used in the regulation, was not intended to preclude multiple designees; if the tire manufacturer desires, he may designate more than one person to maintain the required information. Furthermore, neither the Act nor the regulation prohibits the distributor or dealer from being the manufacturer's designee nor do they prohibit a distributor or dealer from selecting someone to be the manufacturer's designee provided the manufacturer approves of the selection.

“With respect to the possibility of manufacturers using the maintained information to the detriment of a distributor or dealer, the NHTSA will of course investigate claims by distributors or dealers of alleged mis-

49 CFR Ch. V (10–1–10 Edition)

conduct and, if the maintained information is being misused, take appropriate action.

“Issued under the authority of sections 103, 113, and 119 of the National Traffic and Motor Vehicle Safety Act, 15 U.S.C. 1392, 1402, and 1407, and the delegation of authority at 49 CFR 1.51.”

§ 574.1 Scope.

This part sets forth the method by which new tire manufacturers and new tire brand name owners shall identify tires for use on motor vehicles and maintain records of tire purchasers, and the methods by which retreaders and retreaded tire brand name owners shall identify tires for use on motor vehicles. This part also sets forth the methods by which independent tire dealers and distributors shall record, on registration forms, their names and addresses and the identification number of the tires sold to tire purchasers and provide the forms to the purchasers, so that the purchasers may report their names to the new tire manufacturers and new tire brand name owners, and by which other tire dealers and distributors shall record and report the names of tire purchasers to the new tire manufacturers and new tire brand name owners.

(Authority: Secs. 108, 119, and 201, Pub. L. 89–563, 80 Stat. 718 (15 U.S.C. 1392, 1407, and 1421); sec. 4, Pub. L. 97–311, 96 Stat. 1619 (15 U.S.C. 1418); and delegation of authority at 49 CFR 1.50)

[49 FR 4760, Feb. 8, 1984]

§ 574.2 Purpose.

The purpose of this part is to facilitate notification to purchasers of defective or nonconforming tires, pursuant to Sections 30118 and 30119 of Title 49, United States Code, so that they may take appropriate action in the interest of motor vehicle safety.

[61 FR 29495, June 11, 1996]

§ 574.3 Definitions.

(a) *Statutory definitions.* All terms in this part that are defined in Section 30102 of Title 49, United States Code, are used as defined therein.

(b) *Motor vehicle safety standard definitions.* Unless otherwise indicated, all terms used in this part that are defined in the Motor Vehicle Safety Standards, part 571 of this subchapter (hereinafter

the Standards), are used as defined therein.

(c)(1) *Independent* means, with respect to a tire distributor or dealer, one whose business is not owned or controlled by a tire manufacturer or brand name owner.

(2) *Mileage contract purchaser* means a person who purchases or leases tire use on a mileage basis.

(3) *New tire brand name owner* means a person, other than a new tire manufacturer, who owns or has the right to control the brand name of a new tire or a person who licenses another to purchase new tires from a new tire manufacturer bearing the licensor's brand name.

(4) *Retreaded tire brand name owner* means a person, other than a retreader, who owns or has the right to control the brand name of a retreaded tire or a person who licenses another to purchase retreaded tires from a retreader bearing the licensor's brand name.

(5) *Tire purchaser* means a person who buys or leases a new tire, or who buys or leases for 60 days or more a motor vehicle containing a new tire for purposes other than resale.

(Authority: Secs. 103, 108, 112, 119, 201, Pub. L. 89-563, 80 Stat. 718 (15 U.S.C. 1392, 1397, 1401, 1407, 1421); secs. 102, 103, 104, Pub. L. 93-492, 88 Stat. 1470 (15 U.S.C. 1411-1420); 92 Stat. 2689 (15 U.S.C. 1418); delegation of authority at 49 CFR 1.51)

[36 FR 1197, Jan. 26, 1971, as amended at 44 FR 7964, Feb. 8, 1979; 49 FR 38612, Oct. 1, 1984; 61 FR 29495, June 11, 1996]

§ 574.4 Applicability.

This part applies to manufacturers, brand name owners, retreaders, distributors, and dealers of new and retreaded tires, and new non-pneumatic tires and non-pneumatic tire assemblies for use on motor vehicles manufactured after 1948 and to manufacturers and dealers of motor vehicles manufactured after 1948. However, it does not apply to persons who retread tires solely for their own use.

[36 FR 5422, Mar. 23, 1971, as amended at 55 FR 29596, July 20, 1990]

§ 574.5 Tire identification requirements.

Each tire manufacturer shall conspicuously label on one sidewall of

each tire it manufactures, except tires manufactured exclusively for mileage-contract purchasers, or non-pneumatic tires or non-pneumatic tire assemblies, by permanently molding into or onto the sidewall, in the manner and location specified in Figure 1, a tire identification number containing the information set forth in paragraphs (a) through (d) of this section. However, at the option of the manufacturer, the information contained in paragraph (d) of this section may, instead of being permanently molded, be laser etched into or onto the sidewall in the location specified in Figure 1, during the manufacturing process of the tire and not later than 24 hours after the tire is removed from the mold. Each tire retreader, except tire retreaders who retread tires solely for their own use, shall conspicuously label one sidewall of each tire it retreads by permanently molding or branding into or onto the sidewall, in the manner and location specified in Figure 2, a tire identification number containing the information set forth in paragraphs (a) through (d) of this section. However, at the option of the retreader, the information set forth in paragraph (d) of this section may, instead of being permanently molded or branded, be laser etched into or onto the sidewall in the location specified in Figure 2, during the retreading of the tire and not later than 24 hours after the application of the new tread. In addition, the DOT symbol required by Federal Motor Vehicle Safety Standards shall be located as shown in Figures 1 and 2. The DOT symbol shall not appear on tires to which no Federal Motor Vehicle Safety Standard is applicable, except that the DOT symbol on tires for use on motor vehicles other than passenger cars may, prior to retreading, be removed from the sidewall or allowed to remain on the sidewall, at the retreader's option. The symbols to be used in the tire identification number for tire manufacturers and retreaders are: "A, B, C, D, E, F, H, J, K, L, M, N, P, R, T, U, V, W, X, Y, 1, 2, 3, 4, 5, 6, 7, 8, 9, 0". Tires manufactured or retreaded exclusively for mileage-contract purchasers are not required to contain a tire identification number if the tire contains the phrase "for mileage contract use only"

permanently molded into or onto the tire sidewall in lettering at least one-quarter inch high. Each manufacturer of a non-pneumatic tire or a non-pneumatic tire assembly shall permanently mold, stamp or otherwise permanently mark into or onto one side of the non-pneumatic tire or non-pneumatic tire assembly a tire identification number containing the information set forth in paragraphs (a) through (d) of this section. In addition, the DOT symbol required by the Federal motor vehicle safety standards shall be positioned relative to the tire identification number as shown in Figure 1, and the symbols to be used for the other information are those listed above. The labeling for a non-pneumatic tire or a non-pneumatic tire assembly shall be in the manner specified in Figure 1 and positioned on the non-pneumatic tire or non-pneumatic tire assembly such that it is not placed on the tread or the outermost edge of the tire and is not obstructed by any portion of the non-pneumatic rim or wheel center member designated for use with that non-pneumatic tire in S4.4 of Standard No. 129 (49 CFR 571.129).

(a) *First grouping.* The first group, of two or three symbols, depending on whether the tire is new or retreaded, shall represent the manufacturer's assigned identification mark (see § 574.6).

(b) *Second grouping.* For new tires, the second group, of no more than two symbols, shall be used to identify the tire size. For a new non-pneumatic tire or a non-pneumatic tire assembly, the second group, of not more than two symbols, shall be used to identify the non-pneumatic tire identification code. For retreaded tires, the second group, of no more than two symbols, shall identify the retread matrix in which the tire was processed or a tire size code if a matrix was not used to process the retreaded tire. Each new-tire manufacturer and retreader shall maintain a record of each symbol used, with the corresponding matrix or tire

size and shall provide such record to the NHTSA upon written request.

(c) *Third grouping.* The third group, consisting of no more than four symbols, may be used at the option of the manufacturer or retreader as a descriptive code for the purpose of identifying significant characteristics of the tire. However, if the tire is manufactured for a brand name owner, one of the functions of the third grouping shall be to identify the brand name owner. Each manufacturer or retreader who uses the third grouping shall maintain a detailed record of any descriptive or brand name owner code used, which shall be provided to the Bureau upon written request.

(d) *Fourth grouping.* The fourth grouping, consisting of four numerical symbols, must identify the week and year of manufacture. The first two symbols must identify the week of the year by using "01" for the first full calendar week in each year, "02" for the second full calendar week, and so on. The calendar week runs from Sunday through the following Saturday. The final week of each year may include not more than 6 days of the following year. The third and fourth symbols must identify the year. Example: 0101 means the 1st week of 2001, or the week beginning Sunday, January 7, 2001, and ending Saturday, January 13, 2001. The symbols signifying the date of manufacture shall immediately follow the optional descriptive code (paragraph (c) of this section). If no optional descriptive code is used, the symbols signifying the date of manufacture must be placed in the area shown in Figures 1 and 2 of this section for the optional descriptive code.

(e) *Tire identification number height.* Notwithstanding Figures 1 and 2, each character in the tire identification number on tires with less than 6 inches in cross section width or tires with less than 13 inches bead diameter may be any size of 5/32 inches (4 mm) or greater.

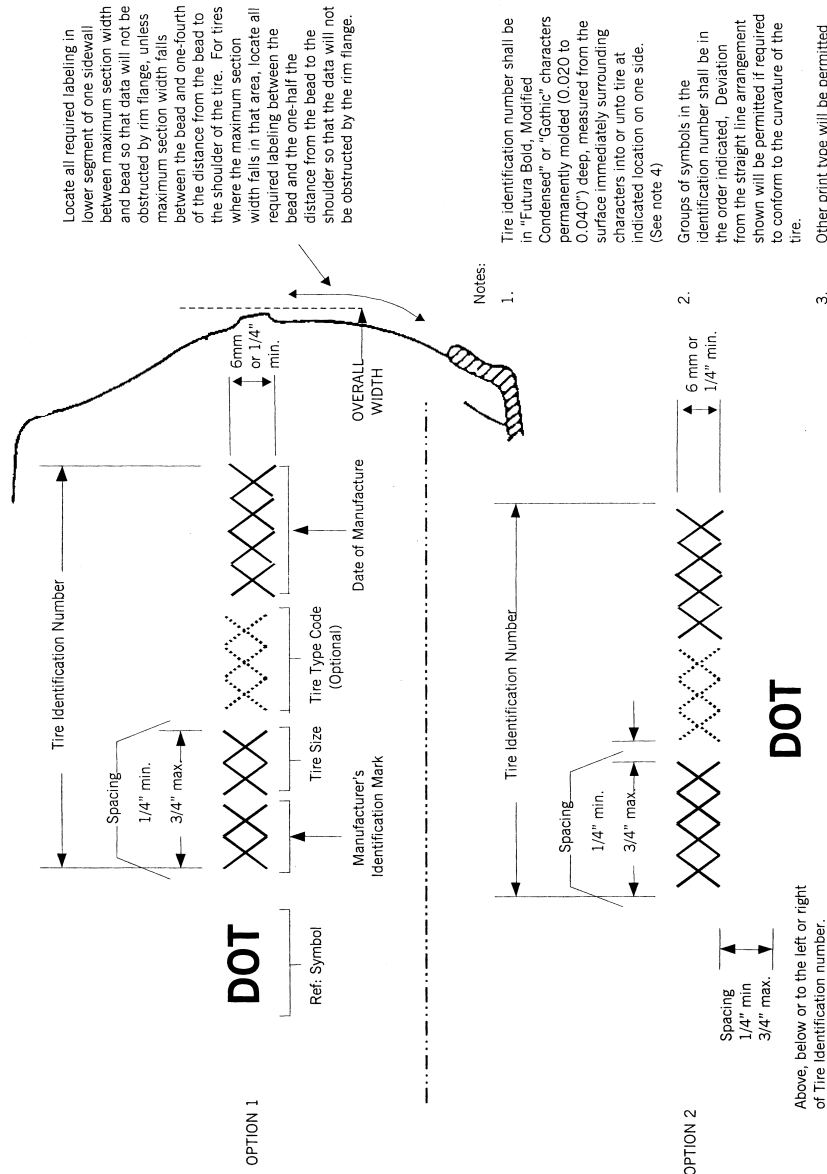


FIGURE 1: IDENTIFICATION NUMBER FOR NEW TIRES

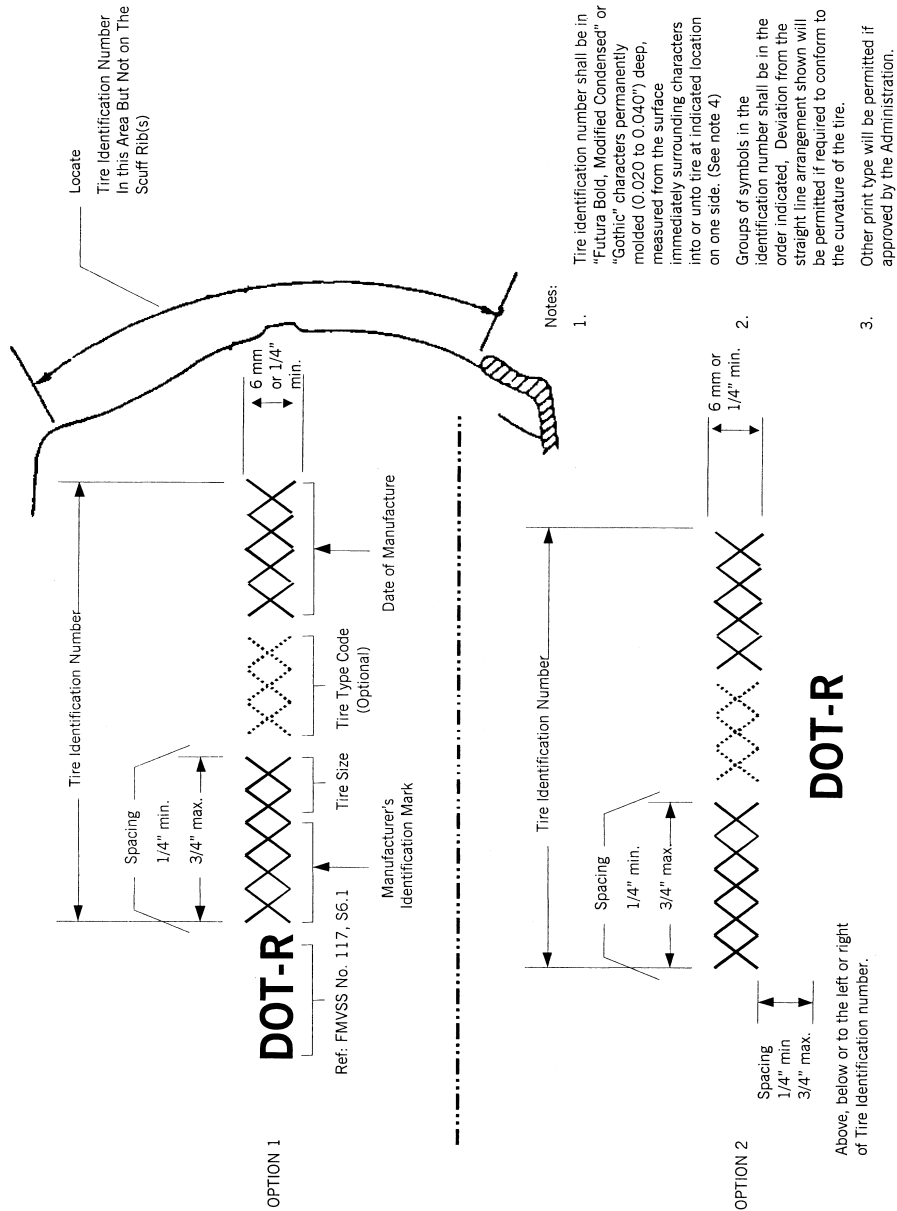


FIGURE 2. IDENTIFICATION NUMBER FOR RETREADED TIRES

[36 FR 1197, Jan. 26, 1971, as amended at 36 FR 9870, May 23, 1971; 37 FR 23727, Nov. 8, 1972; 37 FR 25521, Dec. 1, 1972; 39 FR 5192, Feb. 11, 1974; 39 FR 12105, Apr. 3, 1974; 50 FR 2288, Jan. 16, 1985; 55 FR 29596, July 20, 1990; 64 FR 36812, July 8, 1999; 67 FR 69628, Nov. 18, 2002; 69 FR 31320, June 3, 2004; 69 FR 51400, Aug. 19, 2004; 69 FR 64501, Nov. 5, 2004]

§574.6 Identification mark.

To obtain the identification mark required by 574.5(a), each manufacturer of new or retreaded pneumatic tires, non-pneumatic tires or non-pneumatic tire assemblies shall apply in writing to the Office of Vehicle Safety Compliance, National Highway Traffic Safety Administration, 400 Seventh Street SW., Washington, DC 20590, identify itself as a tire manufacturer or retreader and furnish the following information:

- (a) The name, or other designation identifying the applicant, and its main office address.
- (b) The name, or other identifying designation, of each individual plant operated by the manufacturer and the address of each plant, if applicable.
- (c) The type of tires manufactured at each plant, e.g., pneumatic tires for passenger cars, buses, trucks or motorcycles; pneumatic retreaded tires; or non-pneumatic tires or non-pneumatic tire assemblies.

[55 FR 29596, July 20, 1990, as amended at 61 FR 29495, June 11, 1996]

§574.7 Information requirements—new tire manufacturers, new tire brand name owners.

(a)(1) Each new tire manufacturer and each new tire brand name owner (hereinafter referred to in this section and §574.8 as “tire manufacturer”) or its designee, shall provide tire registration forms to every distributor and dealer of its tires which offers new tires for sale or lease to tire purchasers.

(2) Each tire registration form provided to independent distributors and dealers pursuant to paragraph (a)(1) of this section shall contain space for recording the information specified in paragraphs (a)(4)(i) through (a)(4)(iii) of this section. Each form shall:

- (i) Have the following physical characteristics:
 - (A) Be rectangular;

- (B) Be not less than 3½ inches high, 5 inches long, and 0.007 inches thick;

- (C) Be not more than 4¼ inches high, 6 inches long, and 0.016 inch thick.

- (ii) On the address side of the form, be addressed with the name and address of the manufacturer or its designee, and include, in the upper right hand corner, the statement “Affix a postcard stamp.”

- (iii) On the other side of the form:
 - (A) Include the tire manufacturer’s name, unless it appears on the address side of the form;
 - (B) Include a statement explaining the purpose of the form and how a consumer may register tires. The statement shall:
 - (1) Include the heading “IMPORTANT”.
 - (2) Include the sentence: “In case of a recall, we can reach you only if we have your name and address.”
 - (3) Indicate that sending in the card will add a person to the manufacturer’s recall list.
 - (4) A tire manufacturer may voluntarily provide means for tire registration via the Internet, by telephone or other electronic means. If a tire manufacturer voluntarily provides a Web site or other means by which its tires can be registered, it may (but is not required to) include a sentence listing one or more such means, beginning with the phrase “Instead of mailing this form, you can * * *.” Example: Instead of mailing this form, you can register online at [insert tire manufacturer’s registration Web site address].
 - (5) Include the sentence: “Do it today.”
 - (C) Include space for recording tire identification numbers for six tires.
 - (D) Use shading to distinguish between areas of the form to be filled in by sellers and customers.
 - (1) Include the statement: “Shaded areas must be filled in by seller.”
 - (2) The areas of the form for recording tire identification numbers and information about the seller of the tires must be shaded.
 - (3) The area of the form for recording the customer name and address must not be shaded.
 - (E) Include, in the top right corner, the phrase “OMB Control No. 2127-0050”.

§ 574.8

49 CFR Ch. V (10–1–10 Edition)

(3) Each tire registration form provided to distributors and dealers that are not independent distributors or dealers pursuant to paragraph (a)(1) of this section must contain space for recording the information specified in paragraphs (a)(4)(i) through (a)(4)(iii) of this section. Each form must include:

(A) A statement indicating where the form should be returned, including the name and mailing address of the manufacturer or its designee.

(B) The tire manufacturers' logo or other identification, if the manufacturer is not identified as part of the statement indicating where the form should be returned.

(C) The statement: "IMPORTANT: FEDERAL LAW REQUIRES TIRE IDENTIFICATION NUMBERS MUST BE REGISTERED".

(D) In the top right corner, the phrase "OMB Control No. 2127-0050".

(4)(i) Name and address of the tire purchaser.

(ii) Tire identification number.

(iii) Name and address of the tire seller or other means by which the tire manufacturer can identify the tire seller.

(b) Each tire manufacturer shall record and maintain, or have recorded and maintained for it by a designee, the information from registration forms which are submitted to it or its designee. No tire manufacturer shall use the information on the registration forms for any commercial purpose detrimental to tire distributors and dealers. Any tire manufacturer to which registration forms are mistakenly sent shall forward those registration forms to the proper tire manufacturer within 90 days of the receipt of the forms.

(c) Each tire manufacturer shall maintain, or have maintained for it by a designee, a record of each tire distributor and dealer that purchases tires directly from the manufacturer and sells them to tire purchasers, the number of tires purchased by each such distributor or dealer, the number of tires for which reports have been received from each such distributor or dealer other than an independent distributor or dealer, the number of tires for which reports have been received from each such independent distributor or dealer, the total number of tires for

which registration forms have been submitted to the manufacturer or its designee, and the total number of tires sold by the manufacturer.

(d) The information that is specified in paragraph (a)(4) of this section and recorded on registration forms submitted to a tire manufacturer or its designee shall be maintained for a period of not less than five years from the date on which the information is recorded by the manufacturer or its designee.

(e) Tire manufacturers may voluntarily provide means for tire registration via the Internet, by telephone or other electronic means.

(f) Each tire manufacturer shall meet the requirements of paragraphs (b), (c) and (d) of this section with respect to tire registration information submitted to it or its designee by any means authorized by the manufacturer in addition to the use of registration forms.

(Authority: Secs. 108, 119, and 201, Pub. L. 89-563, 80 Stat. 718 (15 U.S.C. 1392, 1407, and 1421); sec. 4, Pub. L. 97-311, 96 Stat. 1619 (15 U.S.C. 1418); and delegation of authority at 49 CFR 1.50)

[49 FR 4760, Feb. 8, 1984; 49 FR 5621, Feb. 14, 1984, as amended at 56 FR 49427, Sept. 30, 1991; 64 FR 36815, July 8, 1999; 67 FR 45872, July 10, 2002; 71 FR 39233, July 12, 2006; 73 FR 72368, Nov. 28, 2008]

§ 574.8 Information requirements—tire distributors and dealers.

(a) *Independent distributors and dealers.*

(1) Each independent distributor and each independent dealer selling or leasing new tires to tire purchasers or lessors (hereinafter referred to in this section as "tire purchasers") shall comply with paragraph (a)(1)(i), (a)(1)(ii) or (a)(1)(iii) of this section:

(i) At the time of sale or lease of the tire, provide each tire purchaser with a paper tire registration form on which the distributor or dealer has recorded the following information:

(A) The entire tire identification number of the tire(s) sold or leased to the tire purchaser, and

(B) The distributor's or dealer's name and street address. In lieu of the street address, and if one is available, the distributor or dealer's e-mail address or

Web site may be recorded. Other means of identifying the distributor or dealer known to the manufacturer may also be used.

(ii) Record the following information on a paper tire registration form and return it to the tire manufacturer, or its designee, on behalf of the tire purchaser, at no charge to the tire purchaser and within 30 days of the date of sale or lease:

(A) The purchaser's name and address,

(B) The entire tire identification number of the tire(s) sold or leased to the tire purchaser, and

(C) The distributor's or dealer's name and street address. In lieu of the street address, and if one is available, the distributor or dealer's e-mail address or Web site may be recorded. Other means of identifying the distributor or dealer known to the manufacturer may also be used.

(iii) Electronically transmit the following information on the tire registration form by any means listed on the form by the tire manufacturer, or by such other means as may be authorized by the tire manufacturer, to the tire manufacturer or its designee, using secure means (e.g., https on the Web), at no charge to the tire purchaser and within 30 days of the date of sale or lease:

(A) The purchaser's name and address,

(B) The entire tire identification number of the tire(s) sold or leased to the tire purchaser, and

(C) The distributor's or dealer's name and street address. In lieu of the street address, and if one is available, the distributor or dealer's e-mail address or Web site may be recorded. Other means of identifying the distributor or dealer known to the manufacturer may also be used.

(2) Each independent distributor or dealer that complies with paragraph (a)(1)(i) or (ii) of this section shall use either the tire registration forms provided by the tire manufacturers pursuant to §574.7(a) or registration forms obtained from another source. Paper forms obtained from other sources must comply with the requirements specified in §574.7(a) for forms provided

by tire manufacturers to independent distributors and dealers.

(3) Multiple tire sales or leases by the same tire purchaser may be recorded on a single paper registration form or in a single Web site transaction.

(4) Each independent distributor or dealer that is complying with paragraph (a)(1)(iii) with respect to a sale or lease shall include a statement to that effect on the invoice for that sale or lease and provide the invoice to the tire purchaser.

(b) *Other distributors and dealers.*

(1) Each distributor and each dealer, other than an independent distributor or dealer, selling new tires to tire purchasers:

(i) shall submit, using paper registration forms or, if authorized by the tire manufacturer, secure electronic means, the information specified in §574.7(a)(4) to the manufacturer of the tires sold, or to the manufacturer's designee.

(ii) shall submit the information specified in §574.7(a)(4) to the tire manufacturer or the manufacturer's designee, not less often than every 30 days. A distributor or dealer selling fewer than 40 tires of all makes, types and sizes during a 30 day period may wait until a total of 40 new tires is sold. In no event may more than six months elapse before the §574.7(a)(4) information is forwarded to the respective tire manufacturers or their designees.

(c) Each distributor and each dealer selling new tires to other tire distributors or dealers shall supply to the distributor or dealer a means to record the information specified in §574.7(a)(4), unless such means has been provided to that distributor or dealer by another person or by a manufacturer.

(d) Each distributor and each dealer shall immediately stop selling any group of tires when so directed by a notification issued pursuant to 49 U.S.C. 30118, *Notification of defects and non-compliance*.

[73 FR 72363, Nov. 28, 2008]

§574.9 Requirements for motor vehicle dealers.

(a) Each motor vehicle dealer who sells a used motor vehicle for purposes other than resale, who leases a motor

§ 574.10

vehicle for more than 60 days, that is equipped with new tires is considered, for purposes of this part, to be a tire dealer and shall meet the requirements specified in § 574.8.

(b) Each person selling a motor vehicle to first purchasers for purposes other than resale, that is equipped with new tires that were not on the motor vehicle when shipped by the vehicle manufacturer is considered a tire dealer for purposes of this part and shall meet the requirements specified in § 574.8.

(Authority: Secs. 103, 108, 112, 119, 201, Pub. L. 89-563, 80 Stat. 718 (15 U.S.C. 1392, 1397, 1401, 1407, 1421); secs. 102, 103, 104, Pub. L. 93-492, 88 Stat. 1470 (15 U.S.C. 1411-1420); 92 Stat. 2689 (15 U.S.C. 1418); delegation of authority at 49 CFR 1.51)

[44 FR 7964, Feb. 8, 1979]

§ 574.10 Requirements for motor vehicle manufacturers.

Each motor vehicle manufacturer, or his designee, shall maintain a record of the new tires on or in each vehicle shipped by him or a motor vehicle distributor or dealer, and shall maintain a record of the name and address of the first purchaser for purposes other than resale of each vehicle equipped with such tires. These records shall be maintained for a period of not less than 5 years from the date of sale of the vehicle to the first purchaser for purposes other than resale.

(Authority: Secs. 103, 108, 112, 119, 201, Pub. L. 89-563, 80 Stat. 718 (15 U.S.C. 1392, 1397, 1401, 1407, 1421); secs. 102, 103, 104, Pub. L. 93-492, 88 Stat. 1470 (15 U.S.C. 1411-1420); 92 Stat. 2689 (15 U.S.C. 1418); delegation of authority at 49 CFR 1.51)

[44 FR 7964, Feb. 8, 1979, as amended at 67 FR 45872, July 10, 2002]

PART 575—CONSUMER INFORMATION

Subpart A—Regulations Issued Under Section 112(d) of the National Traffic and Motor Vehicle Safety Act; General

Sec.

- 575.1 Scope.
- 575.2 Definitions.
- 575.3 Matter incorporated by reference.
- 575.4 Application.
- 575.5 Separability.
- 575.6 Requirements.

49 CFR Ch. V (10-1-10 Edition)

575.7 Special vehicles.

Subpart B—Regulations; Consumer Information Items

575.101-575.102 [Reserved]

575.103 Truck-camper loading.

575.104 Uniform tire quality grading standards.

575.105 Vehicle rollover.

575.106 Tire fuel efficiency consumer information program.

Subpart C—Transportation Recall Enhancement, Accountability, and Documentation Act; Consumer Information

575.201 Child restraint performance.

Subpart D—Safe, Accountable, Flexible, Efficient Transportation Equity Act: A Legacy for Users (SAFETEA-LU); Consumer Information

575.301 Vehicle Labeling of Safety Rating Information.

AUTHORITY: 49 U.S.C. 32302, 32304A, 30111, 30115, 30117, 30123, 30166, and 30168, Pub. L. 104-414, 114 Stat. 1800, Pub. L. 109-59, 119 Stat. 1144, Pub. L. 110-140, 121 Stat. 1492, 15 U.S.C. 1232(g); delegation of authority at 49 CFR 1.50.

Subpart A—Regulations Issued Under Section 112(d) of the National Traffic and Motor Vehicle Safety Act; General

SOURCE: 35 FR 6867, Apr. 30, 1970, unless otherwise noted.

§ 575.1 Scope.

This part contains National Highway Traffic Safety Administration regulations relating to consumer information.

[75 FR 15944, Mar. 30, 2010]

§ 575.2 Definitions.

(a) *Statutory definitions.*—(1) All terms used in this part, subject to paragraph (a)(2) of this section, that are defined in 49 U.S.C. 30102, are used as defined therein.

(2) All terms used in Subpart D of this part that are defined in 15 U.S.C. 1231, are used as defined therein.

(b) *Motor Vehicle Safety Standard definitions.* Unless otherwise indicated, all terms used in this part that are defined in the Motor Vehicle Safety Standards,

part 571 of this subchapter (hereinafter "the Standards"), are used as defined in the Standards without regard to the applicability of a standard in which a definition is contained.

(c) *Definitions used in this part.*

Owners manual means the document which contains the manufacturers comprehensive vehicle operating and maintenance instructions, and which is intended to remain with the vehicle for the life of the vehicle.

Skid number means the frictional resistance measured in accordance with ASTM E 274 (incorporated by reference, see § 575.3) at 40 miles per hour, omitting water delivery as specified in paragraph 7.1 of ASTM E 274 (incorporated by reference, see § 575.3).

[35 FR 6867, Apr. 30, 1970, as amended at 38 FR 5339, Feb. 28, 1973; 48 FR 44081, Sept. 27, 1983; 54 FR 48749, Nov. 27, 1989; 64 FR 27924, May 24, 1999; 75 FR 15944, Mar. 30, 2010]

§ 575.3 Matter incorporated by reference.

(a) Certain material is incorporated by reference into this part with the approval of the Director of the Federal Register under 5 U.S.C. 552(a) and 1 CFR part 51. To enforce any edition other than that specified in this section, the National Highway Traffic Safety Administration (NHTSA) must publish notice of change in the FEDERAL REGISTER and the material must be available to the public. All approved material is available for inspection at the NHTSA Technical Information Services Reading Room (<http://www.nhtsa.dot.gov/cars/problems/trd/>), 1200 New Jersey Avenue, SE., Washington, DC 20590 (888-327-4236), and at the National Archives and Records Administration (NARA). For information on the availability of this material at NARA, call 202-741-6030, or go to: <http://www.archives.gov/federal-register/cfr/ibr-locations.html>. All approved material is also available from the sources listed below. If you experience difficulty obtaining the standards referenced below, contact NHTSA's Office of Rulemaking, 1200 New Jersey Avenue, SE., Washington, DC 20590, phone number: (202) 366-0846.

(b) *International Organization for Standardization (ISO)*, 1, ch. de la Voie-Creuse, CP 56, CH-1211 Geneva 20, Swit-

zerland, +41 22 749 01 11, <http://www.iso.org/iso/home.htm>. All ISO materials are also available from the U.S. ISO member, *American National Standards Institute (ANSI)*, 25 West 43rd Street, Fourth Floor, New York, NY 10036-7417, 212-642-4900, <http://www.ansi.org/>.

(1) International Organization for Standardization (ISO), ISO 28580:2009(E) ("ISO 28580"), "Passenger car, truck and bus tyres—Methods of measuring rolling resistance—Single point test and correlation of measurement results," First edition (July 1, 2009), IBR approved for § 575.106.

(2) [Reserved]

(c) *American Society for Testing and Materials (ASTM)*, 100 Barr Harbor Drive, PO Box C700, West Conshohocken, PA 19428-2959, 610-832-9500, <http://www.astm.org/>.

(1) ASTM E 1136-93 (Reapproved 2003) ("ASTM E 1136"), "Standard Specification for a Radial Standard Reference Test Tire" (July 1993), IBR approved for § 575.104.

(2) ASTM E 1337-90 (Reapproved 2002) ("ASTM E 1337"), "Standard Test Method for Determining Longitudinal Peak Braking Coefficient of Paved Surfaces Using a Standard Reference Test Tire" (April 1990), IBR approved for § 575.106.

(d) The following standards are not available from the original publisher or a standards reseller. As indicated in paragraph (a) of this section, the standards are available for inspection at the NHTSA Technical Information Services Reading Room (<http://www.nhtsa.dot.gov/cars/problems/trd/>), 1200 New Jersey Avenue, SE., Washington, DC 20590 (888-327-4236), and at NARA. For information on the availability of this material at NARA, call 202-741-6030, or go to: <http://www.archives.gov/federal-register/cfr/ibr-locations.html>. If you experience difficulty obtaining the standards referenced below, contact NHTSA's Office of Rulemaking, 1200 New Jersey Avenue, SE., Washington, DC 20590, phone number (202) 366-0846.

(1) ASTM E 274-79 ("ASTM E 274"), "Standard Test Method for Skid Resistance of Paved Surfaces Using a Full-Scale Tire" (February 1980), IBR approved for § 575.104.

§ 575.4

(2) ASTM F 377-74 (“ASTM F 377”), “Standard Method for Calibration of Braking Force for Testing of Pneumatic Tires” (March 1974), IBR approved for § 575.104.

[75 FR 15944, Mar. 30, 2010]

§ 575.4 Application.

(a) *General.* Except as provided in paragraphs (b) through (d) of this section, each section set forth in subpart B of this part applies according to its terms to motor vehicles and tires manufactured after the effective date indicated.

(b) *Military vehicles.* This part does not apply to motor vehicles or tires sold directly to the Armed Forces of the United States in conformity with contractual specifications.

(c) *Export.* This part does not apply to motor vehicles or tires intended solely for export and so labeled or tagged.

(d) *Import.* This part does not apply to motor vehicles or tires imported for purposes other than resale.

[39 FR 1039, Jan. 4, 1974]

§ 575.5 Separability.

If any section established in this part or its application to any person or circumstances is held invalid, the remainder of the part and the application of that section to other persons or circumstances is not affected thereby.

§ 575.6 Requirements.

(a)(1) At the time a motor vehicle is delivered to the first purchaser for purposes other than resale, the manufacturer of that vehicle shall provide the Uniform Tire Quality Grading information required by § 575.104(d)(1)(iii) in the owner’s manual of each vehicle it produces. The vehicle manufacturer shall also provide to the purchaser, in writing and in the English language, the information specified in § 575.103 of this part that is applicable to that vehicle. The information provided with a vehicle may contain more than one table, but the document must either:

(i) Clearly and unconditionally indicate which of the tables apply to the vehicle with which it is provided, or

(ii) Contain a statement on its cover referring the reader to the vehicle certification label for specific information

49 CFR Ch. V (10–1–10 Edition)

concerning which of the tables apply to that vehicle. If the manufacturer chooses option in paragraph (a)(1)(ii) of this section, the vehicle certification label shall include such specific information.

Example 1. Manufacturer X furnishes a document containing several tables that apply to various groups of vehicles that it produces. The document contains the following notation on its front page: “The information that applies to this vehicle is contained in Table 5.” That notation satisfies the requirement.

Example 2. Manufacturer Y furnishes a document containing several tables as in Example 1, with the following notation on its front page:

“Information applies as follows:

Model P. Regular cab, 135 in. (3,430 mm) wheel base—Table 1.

Model P. Club cab, 142 in. (3,607 mm) wheel base—Table 2.

Model Q—Table 3.”

This notation does not satisfy the requirement, since it is conditioned on the model or the equipment of the vehicle with which the document is furnished, and therefore additional information is required to select the proper table.

(2)(i) At the time a motor vehicle manufactured on or after September 1, 1990 is delivered to the first purchaser for purposes other than resale, the manufacturer shall provide to the purchaser, in writing in the English language and not less than 10 point type, the following statement in the owner’s manual, or, if there is no owner’s manual, on a one-page document:

If you believe that your vehicle has a defect which could cause a crash or could cause injury or death, you should immediately inform the National Highway Traffic Safety Administration (NHTSA) in addition to notifying [INSERT NAME OF MANUFACTURER].

If NHTSA receives similar complaints, it may open an investigation, and if it finds that a safety defect exists in a group of vehicles, it may order a recall and remedy campaign. However, NHTSA cannot become involved in individual problems between you, your dealer, or [INSERT NAME OF MANUFACTURER].

To contact NHTSA, you may call the Vehicle Safety Hotline toll-free at 1-888-327-4236 (TTY: 1-800-424-9153); go to <http://www.safercar.gov>; or write to: Administrator, NHTSA, 400 Seventh Street, SW., Washington, DC 20590. You can also obtain other

information about motor vehicle safety from <http://www.safercar.gov>.

(ii) The manufacturer shall specify in the table of contents of the owner's manual the location of the statement in 575.6(a)(2)(i). The heading in the table of contents shall state "Reporting Safety Defects."

(3) For vehicles manufactured prior to September 1, 2000, at the time a motor vehicle is delivered to the first purchaser for purposes other than resale, the manufacturer of that vehicle shall provide the purchaser, in writing and in the English language, the information specified in §§ 575.103 and 575.104 of this part that is applicable to that vehicle and its tires. The document provided with a vehicle may contain more than one table, but the document must either clearly and unconditionally indicate which of the tables apply to the vehicle with which it is provided, or contain a statement on its cover referring the reader to the vehicle certification label for specific information concerning which of the tables apply to that vehicle. If the manufacturer chooses option (a)(2) of this section, the vehicle certification label shall include such specific information.

Example 1. Manufacturer X furnishes a document containing several tables, which apply to various groups of vehicles that it produces. The document contains the following notation on its front page: "The information that applies to this vehicle is contained in Table 5." The notation satisfies the requirement.

Example 2. Manufacturer Y furnishes a document containing several tables as in Example 1, with the following notation on its front page: Information applies as follows:

Model P, 6-cylinder engine—Table 1.

Model P, 8-cylinder engine—Table 2.

Model Q—Table 3.

This notation does not satisfy the requirement, since it is conditioned on the model or the equipment of the vehicle with which the document is furnished, and therefore additional information is required to select the proper table.

(4) When a motor vehicle that has a GVWR of 10,000 pounds or less, except a motorcycle or low speed vehicle, and that is manufactured on or after September 1, 2005, is delivered to the first purchaser for purposes other than resale, the manufacturer shall provide to the purchaser, in writing in the

English language and not less than 10 point type, a discussion of the items specified in paragraphs (a)(4)(i) through (v) of this section in the owner's manual, or, if there is no owner's manual, in a document:

(i) Tire labeling, including a description and explanation of each marking on the tires provided with the vehicle, and information about the location of the Tire Identification Number (TIN);

(ii) Recommended tire inflation pressure, including a description and explanation of:

(A) Recommended cold tire inflation pressure,

(B) The vehicle placard and tire inflation pressure label specified in Federal Motor Vehicle Safety Standard No. 110 and their location in the vehicle,

(C) Adverse safety consequences of underinflation (including tire failure), and

(D) Measuring and adjusting air pressure to achieve proper inflation;

(iii) Glossary of tire terminology, including "cold tire pressure," "maximum inflation pressure," and "recommended inflation pressure," and all non-technical terms defined in S3 of FMVSS Nos. 110 & 139;

(iv) Tire care, including maintenance and safety practices;

(v) Vehicle load limits, including a description and explanation of:

(A) Locating and understanding load limit information, total load capacity, seating capacity, towing capacity, and cargo capacity,

(B) Calculating total and cargo load capacities with varying seating configurations including quantitative examples showing/illustrating how the vehicle's cargo and luggage capacity decreases as the combined number and size of occupants increases,

(C) Determining compatibility of tire and vehicle load capabilities,

(D) Adverse safety consequences of overloading on handling and stopping and on tires.

(5) When a motor vehicle that has a GVWR of 10,000 pounds or less, except a motorcycle or low speed vehicle, and that is manufactured on or after September 1, 2005, is delivered to the first purchaser for purposes other than resale, the manufacturer shall provide to the purchaser, in writing in the

§575.6

49 CFR Ch. V (10-1-10 Edition)

English language and not less than 10 point type, the following verbatim statement, as applicable, in the owner's manual, or, if there is no owner's manual, in a document:

(i) For vehicles except trailers: "Steps for Determining Correct Load Limit—

(1) Locate the statement "The combined weight of occupants and cargo should never exceed XXX kg or XXX lbs." on your vehicle's placard.

(2) Determine the combined weight of the driver and passengers that will be riding in your vehicle.

(3) Subtract the combined weight of the driver and passengers from XXX kg or XXX lbs.

(4) The resulting figure equals the available amount of cargo and luggage load capacity. For example, if the "XXX" amount equals 1400 lbs. and there will be five 150 lb passengers in your vehicle, the amount of available cargo and luggage load capacity is 650 lbs. (1400-750 (5 × 150) = 650 lbs.)

(5) Determine the combined weight of luggage and cargo being loaded on the vehicle. That weight may not safely exceed the available cargo and luggage load capacity calculated in Step 4.

(6) If your vehicle will be towing a trailer, load from your trailer will be transferred to your vehicle. Consult this manual to determine how this reduces the available cargo and luggage load capacity of your vehicle."

(ii) For trailers: "Steps for Determining Correct Load Limit—

(1) Locate the statement "The weight of cargo should never exceed XXX kg or XXX lbs." on your vehicle's placard.

(2) This figure equals the available amount of cargo and luggage load capacity."

(3) Determine the combined weight of luggage and cargo being loaded on the vehicle. That weight may not safely exceed the available cargo and luggage load capacity.

(b) At the time a motor vehicle tire is delivered to the first purchaser for a purpose other than resale, the manufacturer of that tire, or in the case of a tire marketed under a brand name, the brand name owner, shall provide to that purchaser the information specified in subpart B of this part that is applicable to that tire.

(c) Each manufacturer of motor vehicles, each brand name owner of tires, and each manufacturer of tires for which there is no brand name owner shall provide for examination by prospective purchasers, at each location where its vehicles or tires are offered for sale by a person with whom the manufacturer or brand name owner has a contractual, proprietary, or other legal relationship, or by a person who has such a relationship with a distributor of the manufacturer or brand name owner concerning the vehicle or tire in question, the information specified in subpart B of this part that is applicable to each of the vehicles or tires offered for sale at that location. The information shall be provided without charge and in sufficient quantity to be available for retention by prospective purchasers or sent by mail to a prospective purchaser upon his request. With respect to newly introduced vehicles or tires, the information shall be provided for examination by prospective purchasers not later than the day on which the manufacturer or brand name owner first authorizes those vehicles or tires to be put on general public display and sold to consumers.

(d)(1)(i) Except as provided in paragraph (d)(1)(ii) of this section, in the case of all sections of subpart B other than §575.104, as they apply to information submitted prior to new model introduction, each manufacturer of motor vehicles shall submit to the Administrator 2 copies of the information specified in subpart B of this part that is applicable to the vehicles offered for sale, at least 90 days before information on such vehicles is first provided for examination by prospective purchasers pursuant to paragraph (c) of this section.

(ii) Where an unforeseen preintroduction modification in vehicle design or equipment results in a change in vehicle performance for a characteristic included in subpart B of this part, a manufacturer of motor vehicles may revise information previously furnished under paragraph (d)(1)(i) of this section by submission to the Administrator of 2 copies of the revised information reflecting the performance changes, at least 30 days before information on such vehicles is

first provided to prospective purchasers pursuant to paragraph (c) of this section.

(2)(i) In the case of § 575.104, each brand name owner of tires, and each manufacturer of tires for which there is no brand name owner shall submit to the Administrator 2 copies of the information specified in Subpart B of this part that is applicable to the tires offered for sale, at least 30 days before it is first provided for examination by prospective purchasers pursuant to paragraph (c) of this section.

(ii) In the case of all other sections of Subpart B of this Part as they apply to post-introduction changes in information submitted for the current model year, each manufacturer of motor vehicles, each brand name owner of tires, and each manufacturer of tires for which there is no brand name owner shall submit to the Administrator 2 copies of the information specified in Subpart B of this part that is applicable to the vehicles or tires offered for sale, at least 30 days before it is first provided for examination by prospective purchasers pursuant to paragraph (c) of this section.

[39 FR 1039, Jan. 4, 1974, as amended at 41 FR 13923, Apr. 1, 1976; 45 FR 47153, July 14, 1980; 47 FR 7258, Feb. 18, 1982; 52 FR 27810, July 24, 1987; 54 FR 48749, Nov. 27, 1989; 64 FR 27924, May 24, 1999; 67 FR 69631, Nov. 18, 2002; 69 FR 31320, June 3, 2004; 70 FR 35557, June 21, 2005]

§ 575.7 Special vehicles.

A manufacturer who produces vehicles having a configuration not available for purchase by the general public need not make available to ineligible purchasers, pursuant to § 575.6(c), the information for those vehicles specified in subpart B of this part, and shall identify those vehicles when furnishing the information required by § 575.6(d).

[40 FR 11727, Mar. 13, 1975]

Subpart B—Regulations; Consumer Information Items

§§ 575.101–575.102 [Reserved]

§ 575.103 Truck-camper loading.

(a) *Scope.* This section requires manufacturers of slide-in campers to affix to each camper a label that contains information relating to identification

and proper loading of the camper and to provide more detailed loading information in the owner's manual. This section also requires manufacturers of trucks that would accommodate slide-in campers to specify the cargo weight ratings and the longitudinal limits within which the center of gravity for the cargo weight rating should be located.

(b) *Purpose.* The purpose of this section is to provide information that can be used to reduce overloading and improper load placement in truck-camper combinations and unsafe truck-camper matching in order to prevent accidents resulting from the adverse effects of these conditions on vehicle steering and braking.

(c) *Application.* This section applies to slide-in campers and to trucks that are capable of accommodating slide-in campers.

(d) *Definitions.*

Camper means a structure designed to be mounted in the cargo area of a truck, or attached to an incomplete vehicle with motive power, for the purpose of providing shelter for persons.

Cargo Weight Rating means the value specified by the manufacturer as the cargo-carrying capacity, in pounds or kilograms, of a vehicle, exclusive of the weight of occupants in designated seating positions, computed as 68 kilograms or 150 pounds times the number of designated seating positions.

Slide-in Camper means a camper having a roof, floor, and sides, designed to be mounted on and removable from the cargo area of a truck by the user.

(e) *Requirements—(1) Slide-in Camper—*

(i) *Labels.* Each slide-in camper shall have permanently affixed to it, in such a manner that it cannot be removed without defacing or destroying it, and in a plainly visible location on an exterior rear surface other than the roof, steps, or bumper extension, a label containing the following information in the English language lettered in block capitals and numerals not less than 2.4 millimeters (three thirty-seconds of an inch) high, of a color contrasting with the background, in the order shown below and in the form illustrated in Figure 1.

(A) *Name of camper manufacturer.* The full corporate or individual name of

the actual assembler of the camper shall be spelled out, except that such abbreviations as “Co.” or “Inc.” and their foreign equivalents, and the first and middle initials of individuals may be used. The name of the manufacturer shall be preceded by the words “Manufactured by” or “Mfd by.”

(B) *Month and year of manufacture.* It may be spelled out, such as “June 1995” or expressed in numerals, such as “695.”

(C) The following statement completed as appropriate:

“Camper weight is _____ kg. (_____ lbs.) maximum when it contains _____ standard _____ equipment, _____ liters (_____ gal.) of water, _____ kg. (_____ lbs.) of bottled gas, and _____ cubic meters (_____ cubic ft.) refrigerator (or icebox with _____ kg. (_____ lbs.) of ice, as applicable). Consult owner’s manual (or data sheet, as applicable) for weights of additional or optional equipment.”

(D) “Liters (or gal.) of water” refers to the volume of water necessary to fill the camper’s fresh water tanks to capacity. “Kg. (or lbs.) of bottled gas” refers to the amount of gas necessary to fill the camper’s bottled gas tanks to capacity. The statement regarding a “refrigerator” or “icebox” refers to the capacity of the refrigerator with which the vehicle is equipped or the weight of the ice with which the icebox may be filled. Any of these items may be omitted from the statement if the corresponding accessories are not included with the camper, provided that the omission is noted in the camper owner’s manual as required in paragraph (e)(1)(ii) of this section.

(ii) *Owner’s manual.* Each slide-in camper manufacturer shall provide with each camper a manual or other document containing the information specified in paragraph (e)(1)(ii) (A) through (F) of this section.

(A) The statement and information provided on the label as specified in paragraph (e)(1)(i) of this section. Instead of the information required by paragraphs (e)(1)(i)(B) of this section, a manufacturer may use the statements “See camper identification label located (as applicable) for month and

year of manufacture.” If water, bottled gas, or refrigerator (icebox) has been omitted from this statement, the manufacturer’s information shall note such omission and advise that the weight of any such item when added to the camper should be added to the maximum camper weight figure used in selecting an appropriate truck.

(B) A list of other additional or optional equipment that the camper is designed to carry, and the maximum weight of each if its weight is more than 9 kg. (20 lbs) when installed.

(C) The statement: “To estimate the total cargo load that will be placed on a truck, add the weight of all passengers in the camper, the weight of supplies, tools, and all other cargo, the weight of installed additional or optional camper equipment, and the manufacturer’s camper weight figure. Select a truck that has a cargo weight rating that is equal to or greater than the total cargo load of the camper and whose manufacturer recommends a cargo center of gravity zone that will contain the camper’s center of gravity when it is installed.”

(D) The statements: “When loading this camper, store heavy gear first, keeping it on or close to the camper floor. Place heavy things far enough forward to keep the loaded camper’s center of gravity within the zone recommended by the truck manufacturer. Store only light objects on high shelves. Distribute weight to obtain even side-to-side balance of the loaded vehicle. Secure loose items to prevent weight shifts that could affect the balance of your vehicle. When the truck-camper is loaded, drive to a scale and weigh on the front and on the rear wheels separately to determine axle loads. The load on an axle should not exceed its gross axle weight rating (GAWR). The total of the axle loads should not exceed the gross vehicle weight rating (GVWR). These weight ratings are given on the vehicle certification label that is located on the left side of the vehicle, normally on the dash panel, hinge pillar, door latch post, or door edge next to the driver on trucks manufactured on or after January 1, 1972. If weight ratings are exceeded, move or remove items to bring all weights below the ratings.”

(E) A picture showing the location of the longitudinal center of gravity of the camper within an accuracy of 5 centimeters (2 inches) under the loaded condition specified in paragraph (e)(1)(i)(D) of this section in the manner illustrated in Figure 2.

(F) A picture showing the proper match of a truck and slide-in camper in the form illustrated in Figure 3.

(2) *Trucks.* (i) Except as provided in paragraph (e)(2)(ii) of this section, each manufacturer of a truck that is capable of accommodating a slide-in camper shall provide to the purchaser in the owner's manual or other document delivered with the truck, in writing and in the English language, the information specified in paragraphs (e)(2)(i) (A) through (E) of this section.

(A) A picture showing the manufacturer's recommended longitudinal center of gravity zone for the cargo weight rating in the form illustrated in Figure 4. The boundaries of the zone shall be such that when a slide-in camper equal in weight to the truck's cargo weight rating is installed, no GAWR of the truck is exceeded.

(B) The truck's cargo weight rating.

(C) The statements: "When the truck is used to carry a slide-in camper, the total cargo load of the truck consists of the manufacturer's camper weight figure, the weight of installed additional camper equipment not included in the manufacturer's camper weight figure, the weight of camper cargo, and the weight of passengers in the camper. The total cargo load should not exceed the truck's cargo weight rating and the camper's center of gravity should fall within the truck's recommended center of gravity zone when installed."

(D) A picture showing the proper match of a truck and slide-in camper in the form illustrated in Figure 3.

(E) The statements: "Secure loose items to prevent weight shifts that could affect the balance of your vehicle. When the truck camper is loaded, drive to a scale and weigh on the front and on the rear wheels separately to determine axle loads. Individual axle loads should not exceed either of the gross axle weight ratings (GAWR). The total of the axle loads should not exceed the gross vehicle weight rating (GVWR). These ratings are given on the vehicle certification label that is located on the left side of the vehicle, normally the dash, hinge pillar, door latch post, or door edge next to the driver. If weight ratings are exceeded, move or remove items to bring all weights below the ratings."

(ii) If a truck would accommodate a slide-in camper but the manufacturer of the truck recommends that the truck not be used for that purpose, the information specified in paragraph (e)(2)(i) of this section shall not be provided but instead the manufacturer shall provide a statement that the truck should not be used to carry a slide-in camper.

MFD. BY: (CAMPER MANUFACTURER'S NAME)

(MONTH AND YEAR OF MANUFACTURE)
 CAMPER WEIGHT IS _____ KG
 (_____ LB) MAXIMUM WHEN IT CONTAINS _____ STANDARD EQUIPMENT, _____ LITERS (_____ GAL) OF WATER, _____ KG (_____ LB) OF BOTTLED GAS, AND _____ CUBIC METERS (_____ CUBIC FT) REFRIGERATOR (OR ICEBOX WITH _____ KG (_____ LB) OF ICE, AS APPLICABLE). CONSULT OWNER'S MANUAL (OR DATA SHEET AS APPLICABLE) FOR WEIGHTS OF ADDITIONAL OR OPTIONAL EQUIPMENT.

FIGURE 1. LABEL FOR CAMPER

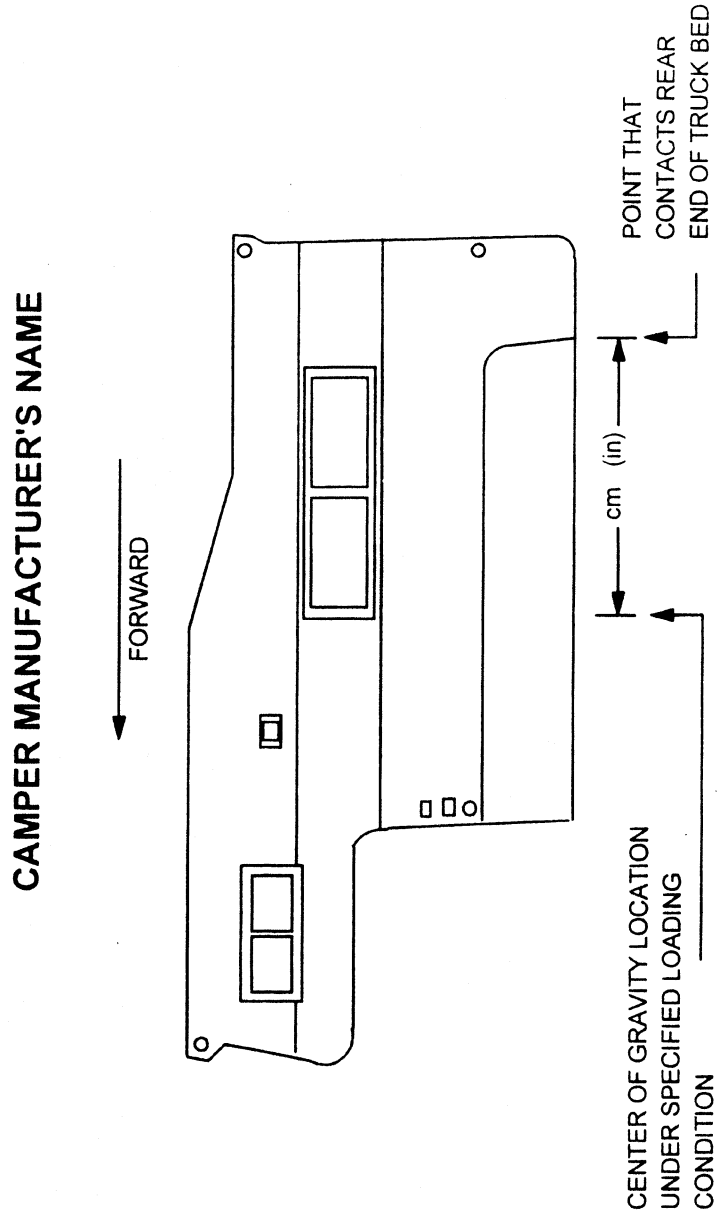


FIGURE 2. CAMPER CENTER OF GRAVITY INFORMATION

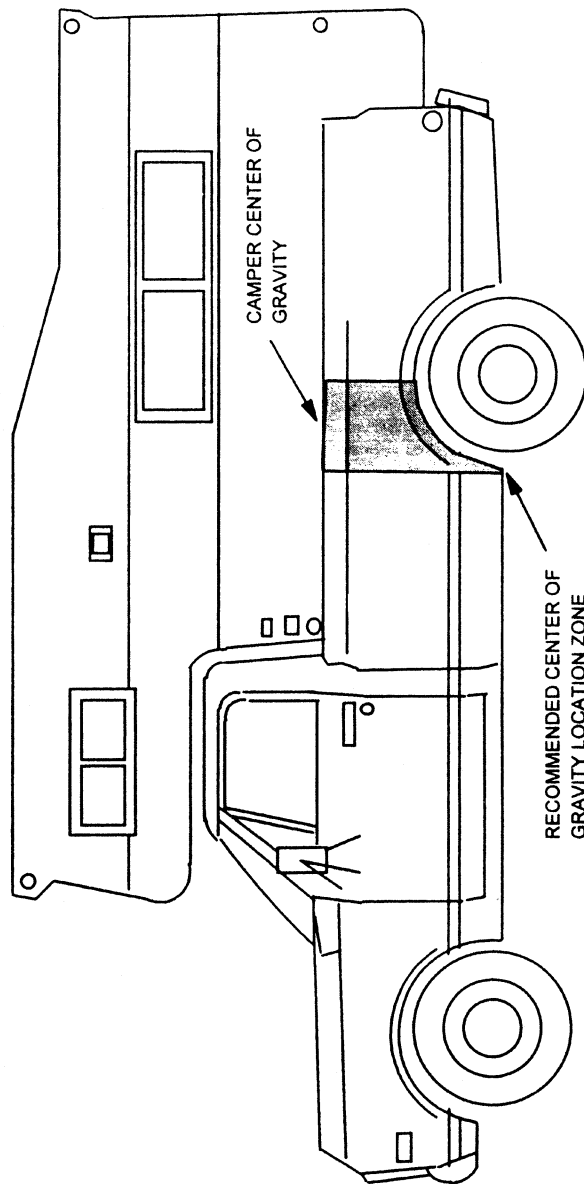


FIGURE 3. EXAMPLE OF PROPER TRUCK AND CAMPER MATCH

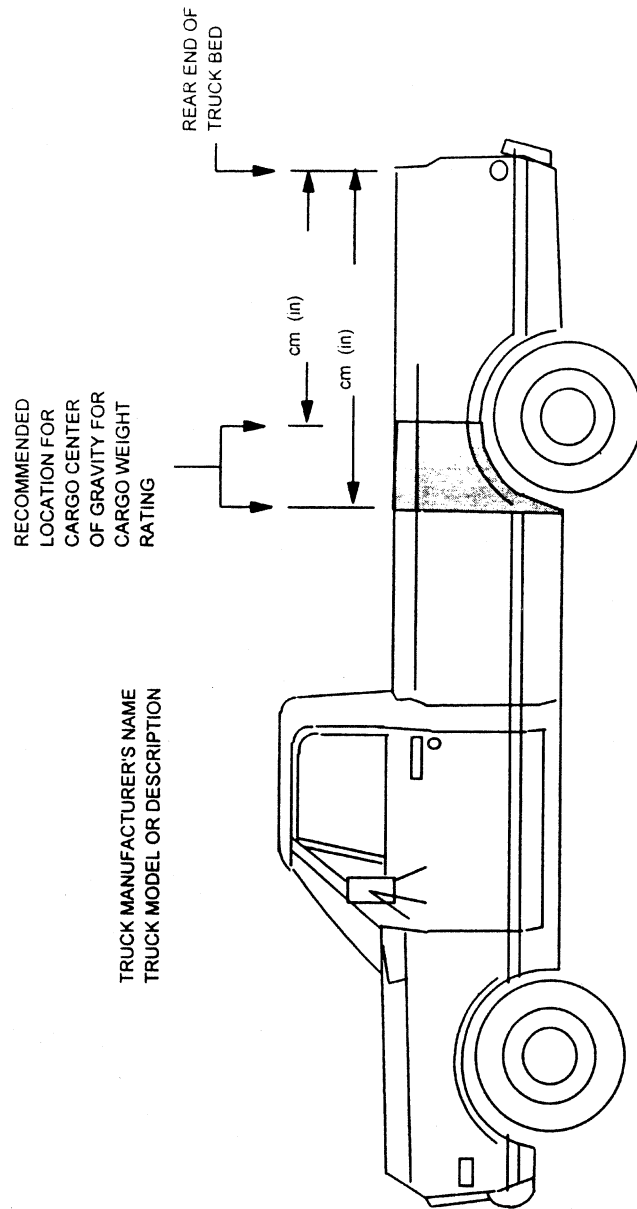


FIGURE 4. TRUCK LOADING INFORMATION

[61 FR 36657, July 12, 1996, as amended at 70 FR 39970, July 12, 2005]

§ 575.104 Uniform tire quality grading standards.

(a) *Scope.* This section requires motor vehicle and tire manufacturers and tire brand name owners to provide information indicating the relative performance of passenger car tires in the areas of treadwear, traction, and temperature resistance.

(b) *Purpose.* The purpose of this section is to aid the consumer in making an informed choice in the purchase of passenger car tires.

(c) *Application.* (1) This section applies to new pneumatic tires for use on passenger cars. However, this section does not apply to deep tread, winter-type snow tires, space-saver or temporary use spare tires, tires with nominal rim diameters of 12 inches or less, or to limited production tires as defined in paragraph (c)(2) of this section.

(2) "Limited production tire" means a tire meeting all of the following criteria, as applicable:

(i) The annual domestic production or importation into the United States by the tire's manufacturer of tires of the same design and size as the tire does not exceed 15,000 tires;

(ii) In the case of a tire marketed under a brand name, the annual domestic purchase or importation into the United States by a brand name owner of tires of the same design and size as the tire does not exceed 15,000 tires;

(iii) The tire's size was not listed as a vehicle manufacturer's recommended tire size designation for a new motor vehicle produced in or imported into the United States in quantities greater than 10,000 during the calendar year preceding the year of the tire's manufacture; and

(iv) The total annual domestic production or importation into the United States by the tire's manufacturer, and in the case of a tire marketed under a brand name, the total annual domestic purchase or purchase for importation into the United States by the tire's brand name owner, of tires meeting the criteria of paragraphs (c)(2) (i), (ii), and (iii) of this section, does not exceed 35,000 tires.

Tire design is the combination of general structural characteristics, materials, and tread pattern, but does in-

clude cosmetic, identifying or other minor variations among tires.

(d) *Requirements—(1) Information.* (i) Each manufacturer of tires, or in the case of tires marketed under a brand name, each brand name owner, shall provide grading information for each tire of which he is the manufacturer or brand name owner in the manner set forth in paragraphs (d)(1)(i) (A) and (B) of this section. The grades for each tire shall be only those specified in paragraph (d)(2) of this section. Each tire shall be able to achieve the level of performance represented by each grade with which it is labeled. An individual tire need not, however, meet further requirements after having been subjected to the test for any one grade.

(A) Except for a tire of a new tire line, manufactured within the first six months of production of the tire line, each tire shall be graded with the words, letters, symbols, and figures specified in paragraph (d)(2) of this section, permanently molded into or onto the tire sidewall between the tire's maximum section width and shoulder in accordance with one of the methods described in Figure 1. For purposes of this paragraph, new tire line shall mean a group of tires differing substantially in construction, materials, or design from those previously sold by the manufacturer or brand name owner of the tires. As used in this paragraph, the term "construction" refers to the internal structure of the tire (e.g., cord angles, number and placement of breakers), "materials" refers to the substances used in manufacture of the tire (e.g., belt fiber, rubber compound), and "design" refers to properties or conditions imposed by the tire mold (e.g., aspect ratio, tread pattern).

(B) Each tire manufactured on and after the effective date of these amendments, other than a tire sold as original equipment on a new vehicle, shall have affixed to its tread surface so as not to be easily removable a label or labels containing its grades and other information in the form illustrated in Figure 2, Parts I and II. The treadwear grade attributed to the tire shall be either imprinted or indelibly stamped on the label containing the material in Part I of Figure 2, directly to the right of or below the word "TREADWEAR."

The traction grade attributed to the tire shall be indelibly circled in an array of the potential grade letters AA, A, B, or C, directly to the right of or below the word “TRACTION” in Part I of Figure 2. The temperature resistance grade attributed to the tire shall be indelibly circled in an array of the potential grade letters A, B, or C, directly to the right of or below the word “TEMPERATURE” in Part I of Figure 2. The words “TREADWEAR,” “TRACTION,” AND “TEMPERATURE,” in that order, may be laid out vertically or horizontally. The text of Part II of Figure 2 may be printed in capital letters. The text of Part I and the text of Part II of Figure 2 need not appear on the same label, but the edges of the two texts must be positioned on the tire tread so as to be separated by a distance of no more than one inch. If the text of Part I and the text of Part II of Figure 2 are placed on separate labels, the notation “See EXPLANATION OF DOT QUALITY GRADES” shall be added to the bottom of the Part I text, and the words “EXPLANATION OF DOT QUALITY GRADES” shall appear at the top of the Part II text. The text of Figure 2 shall be oriented on the tire tread surface with lines of type running perpendicular to the tread circumference. If a label bearing a tire size designation is attached to the tire tread surface and the tire size designation is oriented with lines type running perpendicular to the tread circumference, the text of Figure 2 shall read in the same direction as the tire size designation.

(ii) In the case of the information required by §575.6(c) to be furnished to prospective purchasers of tires, each tire manufacturer or brand name owner shall, as part of that information, list all possible grades for traction and temperature resistance, and restate verbatim the explanation for each performance area specified in Figure 2. The information need not be in the same format as in Figure 2. The information must indicate clearly and unambiguously the grade in each performance area for each tire of that manufacturer or brand name owner offered for sale at the particular location.

(iii) Each manufacturer of motor vehicles equipped with passenger car tires shall include in the owner’s manual of each such vehicle a list of all possible grades for traction and temperature resistance and restate verbatim the explanation for each performance area specified in Figure 2, Part II. The information need not be in the exact format of Figure 2, Part II, but it must contain a statement referring the reader to the tire sidewall for the specific tire grades for the tires with which the vehicle is equipped, as follows:

UNIFORM TIRE QUALITY GRADING

Quality grades can be found where applicable on the tire sidewall between tread shoulder and maximum section width. For example:

TREADWEAR 200 TRACTION AA TEMPERATURE A

(iv) In the case of information required in accordance with §575.6(a) to be furnished to the first purchaser of a new motor vehicle, each manufacturer of motor vehicles shall, as part of the required information, list all possible grades for traction and temperature resistance and restate verbatim the explanation for each performance area specified in Figure 2 to this section. The information need not be in the format of Figure 2 to this section, but it must contain a statement referring the reader to the tire sidewall for the specific tire grades for the tires with which the vehicle is equipped.

(2) *Performance*—(i) *Treadwear*. Each tire shall be graded for treadwear performance with the word “TREADWEAR” followed by a number of two or three digits representing the tire’s grade for treadwear, expressed as a percentage of the NHTSA nominal treadwear value, when tested in accordance with the conditions and procedures specified in paragraph (e) of this section. Treadwear grades shall be expressed in multiples of 20 (for example, 80, 120, 160).

(ii) *Traction*. Each tire shall be graded for traction performance with the word “TRACTION,” followed by the symbols AA, A, B, or C, when the tire is tested in accordance with the conditions and

procedures specified in paragraph (f) of this section.

(A) The tire shall be graded C when the adjusted traction coefficient is either:

(1) 0.38 or less when tested in accordance with paragraph (f)(2) of this section on the asphalt surface specified in paragraph (f)(1)(i) of this section, or

(2) 0.26 or less when tested in accordance with paragraph (f)(2) of this section on the concrete surface specified in paragraph (f)(1)(i) of this section.

(B) The tire may be graded B only when its adjusted traction coefficient is both:

(1) More than 0.38 when tested in accordance with paragraph (f)(2) of this section on the asphalt surface specified in paragraph (f)(1)(i) of this section, and

(2) More than 0.26 when tested in accordance with paragraph (f)(2) of this section on the concrete surface specified in paragraph (f)(1)(i) of this section.

(C) The tire may be graded A only when its adjusted traction coefficient is both:

(1) More than 0.47 when tested in accordance with paragraph (f)(2) of this section on the asphalt surface specified in paragraph (f)(1)(i) of this section, and

(2) More than 0.35 when tested in accordance with paragraph (f)(2) of this section on the concrete surface specified in paragraph (f)(1)(i) of this section.

(D) The tire may be graded AA only when its adjusted traction coefficient is both:

(1) More than 0.54μ when tested in accordance with paragraph (f)(2) of this section on the asphalt surface specified in paragraph (f)(1)(i) of this section; and

(2) More than 0.38μ when tested in accordance with paragraph (f)(2) of this section on the concrete surface specified in paragraph (f)(1)(i) of this section.

(iii) *Temperature resistance.* Each tire shall be graded for temperature resistance performance with the word "TEMPERATURE" followed by the letter A, B, or C, based on its performance when the tire is tested in accordance with the procedures specified in para-

graph (g) of this section. A tire shall be considered to have successfully completed a test stage in accordance with this paragraph if, at the end of the test stage, it exhibits no visual evidence of tread, sidewall, ply, cord, innerliner, or bead separation, chunking, broken cords, cracking or open splices as defined in § 571.109 of this chapter, and the tire pressure is not less than the pressure specified in paragraph (g)(1) of this section.

(A) The tire shall be graded C if it fails to complete the 500 rpm test stage specified in paragraph (g)(9) of this section.

(B) The tire may be graded B only if it successfully completes the 500 rpm test stage specified in paragraph (g)(9) of this section.

(C) The tire may be graded A only if it successfully completes the 575 rpm test stage specified in paragraph (g)(9) of this section.

(e) *Treadwear grading conditions and procedures—(1) Conditions.* (i) Tire treadwear performance is evaluated on a specific roadway course approximately 400 miles in length, which is established by the NHTSA both for its own compliance testing and for that of regulated persons. The course is designed to produce treadwear rates that are generally representative of those encountered by tires in public use. The course and driving procedures are described in appendix A of this section.

(ii) Treadwear grades are evaluated by first measuring the performance of a candidate tire on the government test course, and then correcting the projected mileages obtained to account for environmental variations on the basis of the performance of the course monitoring tires run in the same convoy.

(iii) In convoy tests, each vehicle in the same convoy, except for the lead vehicle, is throughout the test within human eye range of the vehicle immediately ahead of it.

(iv) A test convoy consists of two or four passenger cars, light trucks, or MPVs, each with a GVWR of 10,000 pounds or less.

(v) On each convoy vehicle, all tires are mounted on identical rims of design or measuring rim width specified for tires of that size in accordance with

§ 575.104

49 CFR Ch. V (10–1–10 Edition)

49 CFR 571.109, S4.4.1 (a) or (b), or a rim having a width within -0 to $+0.50$ inches of the width listed.

(2) *Treadwear grading procedure.* (i) Equip a convoy as follows: Place four course monitoring tires on one vehicle. Place four candidate tires with identical size designations on each other vehicle in the convoy. On each axle, place tires that are identical with respect to manufacturer and line.

(ii) Inflate each candidate and each course monitoring tire to the applicable pressure specified in Table 1 of this section.

(iii) Load each vehicle so that the load on each course monitoring and candidate tire is 85 percent of the test load specified in § 575.104(h).

(iv) Adjust wheel alignment to the midpoint of the vehicle manufacturer's specifications, unless adjustment to the midpoint is not recommended by the manufacturer; in that case, adjust the alignment to the manufacturer's recommended setting. In all cases, the setting is within the tolerance specified by the manufacturer of the alignment machine.

(v) Subject candidate and course monitoring tires to "break-in" by running the tires in the convoy for two circuits of the test roadway (800 miles). At the end of the first circuit, rotate each vehicle's tires by moving each front tire to the same side of the rear axle and each rear tire to the opposite side of the front axle. Visually inspect each tire for any indication of abnormal wear, tread separation, bulging of the sidewall, or any sign of tire failure. Void the grading results from any tire with any of these anomalies, and replace the tire.

(vi) After break-in, allow the air pressure in the tires to fall to the applicable pressure specified in Table 1 of this section or for 2 hours, whichever occurs first. Measure, to the nearest 0.001 inch, the tread depth of each candidate and each course monitoring tire, avoiding treadwear indicators, at six equally spaced points in each groove. For each tire compute the average of the measurements. Do not measure those shoulder grooves which are not provided with treadwear indicators.

(vii) Adjust wheel alignment to the midpoint of the manufacturer's speci-

fications, unless adjustment to the midpoint is not recommended by the manufacturer; in that case, adjust the alignment according to the manufacturer's recommended setting. In all cases, the setting is within the tolerance specified by the manufacturer of the alignment machine.

(viii) Drive the convoy on the test roadway for 6,400 miles.

(A) After each 400 miles, rotate each vehicle's tires by moving each front tire to the same side of the rear axle and each rear tire to the opposite side of the front axle. Visually inspect each tire for treadwear anomalies.

(B) After each 800 miles, rotate the vehicles in the convoy by moving the last vehicle to the lead position. Do not rotate driver positions within the convoy. In four-car convoys, vehicle one shall become vehicle two, vehicle two shall become vehicle three, vehicle three shall become vehicle four, and vehicle four shall become vehicle one.

(C) After each 800 miles, if necessary, adjust wheel alignment to the midpoint of the vehicle manufacturer's specification, unless adjustment to the midpoint is not recommended by the manufacturer; in that case, adjust the alignment to the manufacturer's recommended setting. In all cases, the setting is within the tolerance specified by the manufacturer of the alignment machine.

(D) After each 800 miles, if determining the projected mileage by the 9-point method set forth in (e)(2)(ix)(A)(1), measure the average tread depth of each tire following the procedure set forth in paragraph (e)(2)(vi) of this section.

(E) After each 1,600 miles, move the complete set of four tires to the following vehicle. Move the tires on the last vehicle to the lead vehicle. In moving the tires, rotate them as set forth in (e)(2)(viii)(A) of this section.

(F) At the end of the test, measure the tread depth of each tire pursuant to the procedure set forth in paragraph (e)(2)(vi) of this section.

(ix)(A) Determine the projected mileage for each candidate tire either by the nine-point method of least squares set forth in paragraph (e)(2)(ix)(A)(1) of this section and appendix C to this section, or by the two-point arithmetical

method set forth in paragraph (e)(2)(ix)(A)(2) of this section. Notify NHTSA about which of the alternative grading methods is being used.

(1) *Nine-Point Method of Least Squares.* For each course monitoring and candidate tire in the convoy, using the average tread depth measurements obtained in accordance with paragraphs (e)(2)(vi) and (e)(2)(viii)(D) of this section and the corresponding mileages as data points, apply the method of least squares as described in appendix C to this section to determine the estimated regression line of y on x given by the following formula:

$$y = a + \frac{bx}{1000}$$

Where:

y = average tread depth in mils

x = miles after break-in,

a = y intercept of regression line (reference tread depth) in mils, calculated using the method of least squares; and

b = the slope of the regression line in mils of tread depth per 1,000 miles, calculated using the method of least squares. This slope will be negative in value. The tire's wear rate is defined as the absolute value of the slope of the regression line.

(2) *Two-Point Arithmetical Method.* For each course monitoring and candidate tire in the convoy, using the average tread depth measurements obtained in accordance with paragraph (e)(2)(vi) and (e)(2)(viii)(F) of this section and the corresponding mileages as data points, determine the slope (m) of the tire's wear in mils of tread depth per 1,000 miles by the following formula:

$$m = 1000 \frac{(Y1 - Y0)}{(X1 - X0)}$$

Where:

Y0 = average tread depth after break-in, mils

Y1 = average tread depth at 6,400 miles, mils

X0 = 0 miles (after break-in).

X1 = 6,400 miles of travel

This slope (m) will be negative in value. The tire's wear rate is defined as the slope (m) expressed in mils per 1,000 miles.

(B) Average the wear rates of the four course monitoring tires as determined in accordance with paragraph (e)(2)(ix)(A) of this section.

(C) Determine the course severity adjustment factor by dividing the base

course wear rate for the course monitoring tires (*see Note* to this paragraph) by the average wear rate for the four course monitoring tires.

Note to paragraph (e)(2)(ix)(C): The base wear rate for the course monitoring tires will be obtained by the government by running the tire specified in ASTM E 1136 (incorporated by reference, *see* §575.3) course monitoring tires for 6,400 miles over the San Angelo, Texas, UTQGS test route 4 times per year, then using the average wear rate from the last 4 quarterly CMT tests for the base course wear rate calculation. Each new base course wear rate will be published in the FEDERAL REGISTER. The course monitoring tires used in a test convoy must be no more than one year old at the commencement of the test and must be used within two months after removal from storage.

(D) Determine the adjusted wear rate for each candidate tire by multiplying its wear rate determined in accordance with paragraph (e)(2)(ix)(A) of this section by the course severity adjustment factor determined in accordance with paragraph (e)(2)(ix)(C) of this section.

(E) Determine the projected mileage for each candidate tire by applying the appropriate formula set forth below:

(1) If the projected mileage is calculated pursuant to paragraph (e)(2)(ix)(A)(1) of this section, then:

$$\text{Projected mileage} = \frac{1000(a - 62)}{b^1} + 800$$

Where:

a = y intercept of regression line (reference tread depth) for the candidate tire as determined in accordance with paragraph (e)(2)(ix)(A)(1) of this section.

b¹ = the adjusted wear rate for the candidate tire as determined in accordance with paragraph (e)(2)(ix)(D) of this section.

(2) If the projected mileage is calculated pursuant to (e)(2)(ix)(a)(2) of this section, then:

$$\text{Projected mileage} = \frac{-1000(Y0 - 62)}{mc} + 800$$

Where:

Y0 = average tread depth after break-in, mils

mc = the adjusted wear rate for the candidate tires as determined in accordance with paragraph (e)(2)(ix)(D) of this section.

§575.104

(F) Compute the grade (P) of the NHTSA nominal treadwear value for each candidate tire by using the following formula:

$$P = \text{Projected mileage} \times \text{base course wear rate}_n / 402$$

Where base course wear rate_n = new base course wear rate, *i.e.*, average treadwear of the last 4 quarterly course monitoring tire tests conducted by NHTSA.

Round off the percentage to the nearest lower 20-point increment.

(f) *Traction grading conditions and procedures*—(1) *Conditions*. (i) Tire traction performance is evaluated on skid pads that are established, and whose severity is monitored, by the NHTSA both for its compliance testing and for that of regulated persons. The test pavements are asphalt and concrete surfaces constructed in accordance with the specifications for pads “C” and “A” in the “Manual for the Construction and Maintenance of Skid Surfaces,” National Technical Information Service No. DOT-HS-800-814. The surfaces have locked wheel traction coefficients when evaluated in accordance with paragraphs (f)(2)(i) through (f)(2)(vii) of this section of 0.50 ±0.10 for the asphalt and 0.35 ±0.10 for the concrete. The location of the skid pads is described in appendix B to this section.

(ii) The standard tire is the tire specified in ASTM E 501 (incorporated by reference, *see* §575.3).

(iii) The pavement surface is wetted in accordance with paragraph 4.7, “Pavement Wetting System,” of ASTM E 274 (incorporated by reference, *see* §575.3).

(iv) The test apparatus is a test trailer built in conformity with the specifications in paragraph 4, “Apparatus,” of ASTM E 274 (incorporated by reference, *see* §575.3). The test apparatus is instrumented in accordance with paragraph 4.5 of that method, except that the “wheel load” in paragraph 4.3 and tire and rim specifications in paragraph 4.4 of that method are as specified in the procedures in paragraph (f)(2) of this section for standard and candidate tires.

(v) The test apparatus is calibrated in accordance with ASTM F 377 (incorporated by reference, *see* §575.3), with

49 CFR Ch. V (10–1–10 Edition)

the trailer’s tires inflated to 24 psi and loaded to 1,085 pounds.

(vi) Consecutive tests on the same surface are conducted not less than 30 seconds apart.

(vii) A standard tire is discarded in accordance with ASTM E 501 (incorporated by reference, *see* §575.3).

(2) *Procedure*. (i) Prepare two standard tires as follows:

(A) Condition the tires by running them for 200 miles on a pavement surface.

(B) Mount each tire on a rim of design or measuring rim width specified for tires of its size in accordance with 49 CFR 571.109, S4.4.1 (a) or (b), or a rim having a width within –0 to +0.50 inches of the width listed. Then inflate the tire to 24 psi, or, in the case of a tire with inflation pressure measured in kilopascals, to 180 kPa.

(C) Statically balance each tire-rim combination.

(D) Allow each tire to cool to ambient temperature and readjust its inflation pressure to 24 psi, or, in the case of a tire with inflation pressure measured in kilopascals, to 180 kPa.

(ii) Mount the tires on the test apparatus described in paragraph (f)(1)(iv) of this section and load each tire to 1,085 pounds.

(iii) Tow the trailer on the asphalt test surface specified in paragraph (f)(1)(i) of this section at a speed of 40 mph, lock one trailer wheel, and record the locked-wheel traction coefficient on the tire associated with that wheel between 0.5 and 1.5 seconds after lock-up.

(iv) Repeat the test on the concrete surface, locking the same wheel.

(v) Repeat the tests specified in paragraphs (f)(2) (iii) and (iv) of this section for a total of 10 measurements on each test surface.

(vi) Repeat the procedures specified in paragraphs (f)(2) (iii) through (v) of this section, locking the wheel associated with the other tire.

(vii) Average the 20 measurements taken on the asphalt surface to find the standard tire traction coefficient for the asphalt surface. Average the 20 measurements taken on the concrete

surface to find the standard tire traction coefficient for the concrete surface. The standard tire traction coefficient so determined may be used in the computation of adjusted traction coefficients for more than one candidate tire.

(viii) Prepare two candidate tires of the same construction type, manufacturer, line, and size designation in accordance with paragraph (f)(2)(i) of this section, mount them on the test apparatus, and test one of them according to the procedures of paragraph (f)(2)(ii) through (v) of this section, except load each tire to 85% of the test load specified in §575.104(h). For CT tires, the test inflation of candidate tires shall be 230 kPa. Candidate tire measurements may be taken either before or after the standard tire measurements used to compute the standard tire traction coefficient. Take all standard tire and candidate tire measurements used in computation of a candidate tire's adjusted traction coefficient within a single three hour period. Average the 10 measurements taken on the asphalt surface to find the candidate tire traction coefficient for the asphalt surface. Average the 10 measurements taken on the concrete surface to find the candidate tire traction coefficient for the concrete surface.

(ix) Compute a candidate tire's adjusted traction coefficient for asphalt (μ_a) by the following formula:

$$\mu_a = \text{Measured candidate tire coefficient for asphalt} + 0.50 - \text{Measured standard tire coefficient for asphalt}$$

(x) Compute a candidate tire's adjusted traction coefficient for concrete (μ_c) by the following formula:

$$\mu_c = \text{Measured candidate tire coefficient for concrete} + 0.35 \mu - \text{Measured standard tire coefficient for concrete}$$

(g) *Temperature resistance grading.* (1) Mount the tire on a rim of design or

measuring rim width specified for tires of its size in accordance with §571.109, paragraph S4.4.1 (a) or (b) and inflate it to the applicable pressure specified in Table 1 of this section.

(2) Condition the tire-rim assembly to a temperature of 95 °F for at least 3 hours.

(3) Adjust the pressure again to the applicable pressure specified in Table 1 of this section.

(4) Mount the tire-rim assembly on an axle, and press the tire tread against the surface of a flat-faced steel test wheel that is 67.23 inches in diameter and at least as wide as the section width of the tire.

(5) During the test, including the pressure measurements specified in paragraphs (g) (1) and (3) of this section, maintain the temperature of the ambient air, as measured 12 inches from the edge of the rim flange at any point on the circumference on either side of the tire at 95 °F. Locate the temperature sensor so that its readings are not affected by heat radiation, drafts, variations in the temperature of the surrounding air, or guards or other devices.

(6) Press the tire against the test wheel with a load of 88 percent of the tire's maximum load rating as marked on the tire sidewall.

(7) Rotate the test wheel at 250 rpm for 2 hours.

(8) Remove the load, allow the tire to cool to 95 °F or for 2 hours, whichever occurs last, and readjust the inflation pressure to the applicable pressure specified in Table 1 of this section.

(9) Reapply the load and without interruption or readjustment of inflation pressure, rotate the test wheel at 375 rpm for 30 minutes, and then at successively higher rates in 25 rpm increments, each for 30 minutes, until the tire has run at 575 rpm for 30 minutes, or to failure, whichever occurs first.

TABLE I—TEST INFLATION PRESSURES
[Maximum permissible inflation pressure for the following test]

Test type	Tires other than CT tires									CT tires			
	psi				kPa					kPa			
	32	36	40	60	240	280	300	340	350	290	330	350	390
Treadwear test	24	28	32	52	180	220	180	220	180	230	270	230	270
Temperature resistant test	30	34	38	58	220	260	220	260	220	270	310	270	310

§ 575.104

49 CFR Ch. V (10–1–10 Edition)

(h) *Determination of test load.* (1) To determine test loads for purposes of paragraphs (e)(2)(iii) and (f)(2)(viii), follow the procedure set forth in paragraphs (h) (2) through (5) of this section.

(2) Determine the tire's maximum inflation pressure and maximum load rating both as specified on the tire's sidewall.

(3) Determine the appropriate multiplier corresponding to the tire's maximum inflation pressure, as set forth in Table 2.

(4) Multiply the tire's maximum load rating by the multiplier determined in paragraph (h)(3). This is the tire's calculated load.

(5) Round the product determined in paragraph (h)(4) (the calculated load) to the nearest multiple of ten pounds or, if metric units are used, 5 kilograms. For example, 903 pounds would

be rounded to 900 and 533 kilograms would be rounded to 535. This figure is the test load.

TABLE 2

Maximum inflation pressure	Multiplier to be used for treadwear testing	Multiplier to be used for traction testing
Tires other than CT tires		
32 psi851	.851
36 psi870	.797
40 psi883	.753
240 kPa866	.866
280 kPa887	.804
300 kPa866	.866
340 kPa887	.804
350 kPa866	.866
CT tires		
290 kPa866	.866
330 kPa887	.804
305 kPa866	.866
390 kPa887	.804

TABLE 2A

Tire size designation	Temp resistance			Traction	Treadwear		
	Max pressure				Max pressure		
	32	36	40		32	36	40
145/70 R13	615	650	685	523	523	553	582
155/70 R13	705	740	780	599	599	629	663
165/70 R13	795	835	880	676	676	710	748
175/70 R13	890	935	980	757	757	795	833
185/70 R13	990	1040	1090	842	842	884	926
195/70 R13	1100	1155	1210	935	935	982	1029
155/70 R14	740	780	815	629	629	663	693
175/70 R14	925	975	1025	786	786	829	871
185/70 R14	1045	1100	1155	888	888	935	982
195/70 R14	1155	1220	1280	982	982	1037	1088
155/70 R15	770	810	850	655	655	689	723
175/70 R15	990	1040	1090	842	842	884	927
185/70 R15	1100	1155	1210	935	935	982	1029
5.60–13	725	810	880	616	616	689	748
5.20–14	695	785	855	591	591	667	727
165–15	915	1,015	1,105	779	779	863	939
185/60 R 13	845	915	980	719	719	778	833

(i)–(l) [Reserved]

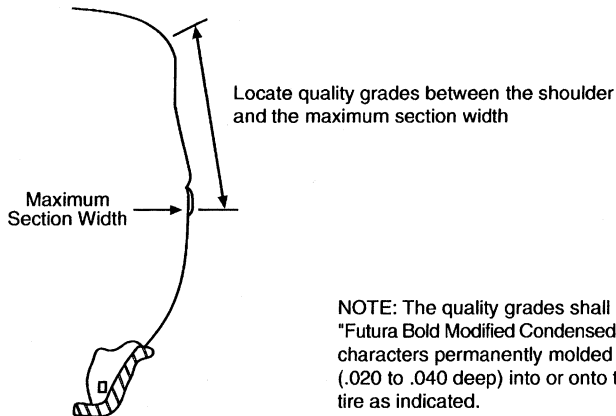
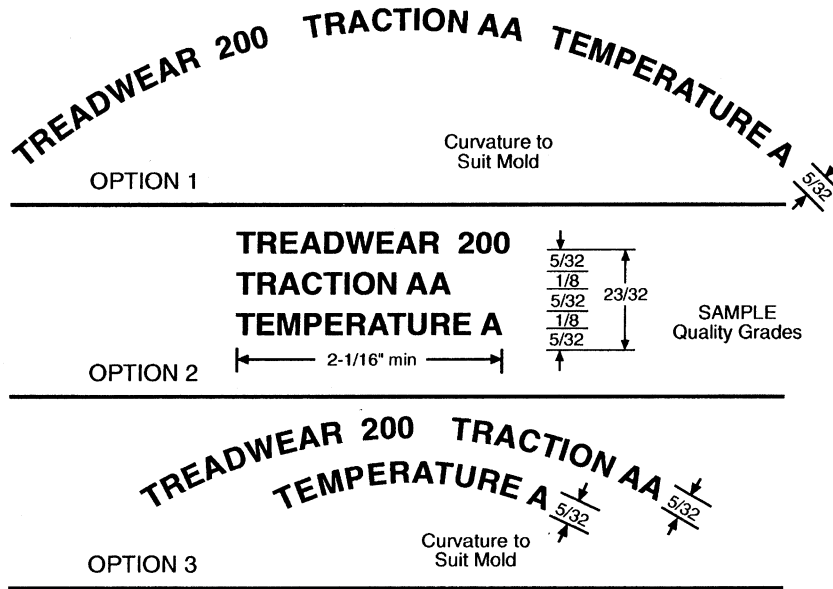


Figure 1

FIGURE 2—[PART I]—DOT QUALITY GRADES
TREADWEAR

TRACTION AA A B C
TEMPERATURE A B C

(Part II) All Passenger Car Tires Must Conform to Federal Safety Requirements in Addition to These Grades

TREADWEAR

The treadwear grade is a comparative rating based on the wear rate of the tire when tested under controlled conditions on a specified government test course. For example, a tire graded 150 would wear one and one-half (1½) times as well on the government course as a tire graded 100. The relative performance of tires depends upon the actual conditions of their use, however, and may depart significantly from the norm due to variations in driving habits, service practices and differences in road characteristics and climate.

TRACTION

The traction grades, from highest to lowest, are AA, A, B, and C. Those grades represent the tire's ability to stop on wet pavement as measured under controlled conditions on specified government test surfaces of asphalt and concrete. A tire marked C may have poor traction performance. Warning: The traction grade assigned to this tire is based on straight-ahead braking traction tests, and does not include acceleration, cornering, hydroplaning, or peak traction characteristics.

TEMPERATURE

The temperature grades are A (the highest), B, and C, representing the tire's resistance to the generation of heat and its ability to dissipate heat when tested under controlled conditions on a specified indoor laboratory test wheel. Sustained high temperature can cause the material of the tire to degenerate and reduce tire life, and excessive temperature can lead to sudden tire failure. The grade C corresponds to a level of performance which all passenger car tires must meet under the Federal Motor Safety Standard No. 109. Grades B and A represent higher levels of performance on the laboratory test wheel than the minimum required by law. Warning: The temperature grade for this tire is established for a tire that is properly inflated and not overloaded. Excessive speed, underinflation, or excessive loading, either separately or in combination, can cause heat buildup and possible tire failure.

APPENDIX A—TREADWEAR TEST COURSE AND DRIVING PROCEDURES

Introduction. The test course consists of three loops of a total of 400 miles in the geographical vicinity of Goodfellow AFB, San Angelo, Tex.

The first loop runs south 143 miles through the cities of Eldorado, Sonora, and Juno, Tex. to the Camp Hudson Historical Marker, and returns by the same route.

The second loop runs east over Farm and Ranch Roads (FM) and returns to its starting point.

The third loop runs northwest to Water Valley, northeast toward Robert Lee and returns via Texas 208 to the vicinity of Goodfellow AFB.

Route. The route is shown in Figure 3. The table identifies key points by number. These numbers are encircled in Figure 3 and in parentheses in the descriptive material that follows.

Southern Loop. The course begins at the intersection (1) of Ft. McKavitt Road and Paint Rock Road (FM388) at the northwest corner of Goodfellow AFB. Drive east via FM 388 to junction with Loop Road 306 (2). Turn right onto Loop Road 306 and proceed south to junction with US277 (3). Turn onto US277 and proceed south through Eldorado and Sonora (4), continuing on US277 to junction with FM189 (5). Turn right onto FM189 and proceed to junction with Texas 163 (6). Turn left onto Texas 163, and at the option of the manufacturer:

(A) Proceed south to Camp Hudson Historical Marker and onto the paved shoulder (7). Reverse route to junction of Loop Road 306 and FM 388 (2); or

(B) Proceed south to junction with Frank's Crossing. Reverse route at Frank's Crossing and proceed north on Texas 163 to junction with Highway 189; Reverse route at junction with Highway 189; proceed south on Texas 163 to junction with Frank's Crossing; reverse route at Frank's Crossing and proceed north to junction of Loop Road 306 and FM 388 (2).

Eastern Loop. From junction of Loop Road 306 and FM388 (2), make right turn onto FM388 and drive east to junction with FM2334 (13). Turn right onto FM2334 and proceed south across FM765 (14) to junction of FM2334 and US87 (15). For convoys that originate at Goodfellow AFB, make U-turn and return to junction of FM388 and Loop Road 306 (2) by the same route. For convoys that do not originate at Goodfellow AFB, upon reaching junction of FM2334 and US87 (15), make U-Turn and continue north on FM2334 past the intersection with FM388 to Veribest Cotton Gin, a distance of 1.8 miles beyond the intersection. Make U-turn and return to junction of FM2334 and FM388. Turn right onto FM388, proceed west to junction FM388 and Loop Road 306.

Northwestern Loop. From junction of Loop Road 306 and FM388 (2), make right turn onto Loop Road 306. Proceed onto US277, to junction with FM2105 (8). Turn left onto FM2105 and proceed west to junction with US87 (10). Turn right on US87 and proceed northwest to the junction with FM2034 near the town of Water Valley (11). Turn right onto FM2034 and proceed north to Texas 208 (12). Turn right onto Texas 208 and proceed south to junction with FM2105 (9). Turn left onto FM2105 and proceed east to junction with

US277 (8). Turn right onto US277 and proceed south onto Loop Road 306 to junction with FM388 (2). For convoys that originate at Goodfellow AFB, turn right onto FM388 and proceed to starting point at junction of Ft. McKavitt Road and FM388 (1). For convoys that do not originate at Goodfellow AFB, do not turn right onto FM388 but continue south on Loop Road 306.

Driving instructions. The drivers shall run at posted speed limits throughout the course unless an unsafe condition arises. If such condition arises, the speed should be reduced to the maximum safe operating speed.

Braking Procedures at STOP signs. There are a number of intersections at which stops are required. At each of these intersections a se-

ries of signs is placed in a fixed order at follows:

SIGN LEGEND

Highway Intersection 1000 (or 2000) Feet
STOP AHEAD
Junction XXX
Direction Sign (Mereta→)
STOP or YIELD

Procedures. 1. Approach each intersection at posted speed limit.

2. When abreast of the STOP AHEAD sign, apply the brakes so that the vehicle decelerates smoothly to 20 mph when abreast of the direction sign.

3. Come to a complete stop at the STOP sign or behind any vehicle already stopped.

KEY POINTS ALONG TREADWEAR
TEST COURSE, APPROX. MILEAGES,
AND REMARKS

	<i>Mileages</i>	<i>Remarks</i>
1 Ft. McKavitt Road & FM 388	0	
2 FM388 & Loop 306 *	2	STOP
3 Loop 306 & US277 . .	10	
4 Sonora	72	
5 US 277 & FM 189 . .	88	
6 FM 189 & Texas 163 .	124	
7 Historical Marker . . . (Camp Hudson)	143	U-TURN
4 Sonora	214	
3 Loop 306 & US 277 . .	276	
2 FM 388 & Loop 306 .	283	
13 FM 388 & FM 2334 †	290	STOP
14 FM 2334 & FM 765 . .	292	STOP
15 FM 2334 & US 87 . . .	295	U-TURN
14 FM 2334 & FM 765 . .	298	STOP
13 FM 388 & FM 2334 . .	300	STOP/YIELD/ BLINKING RED LIGHT
2 FM 388 & Loop 306	307	STOP/YIELD/ BLINKING RED LIGHT
8 US 277 & FM 2105 . .	313	
9 FM 2105 & Texas 208	317	STOP
10 FM 2105 & US 87 . . .	320	STOP
11 FM 2034 & US 87 . . .	338	
12 FM 2034 & Texas 208	362	YIELD
9 FM 2105 & Texas 208	387	
8 FM 2105 & US 277 . .	391	YIELD/STOP
2 FM 388 & Loop 306 *	398	
1 Ft. McKavitt Road & FM 388	400	
16 Veribest Cotton Gin .	1.8	U-TURN

* Convoys not originating at Goodfellow AFB will not traverse the leg of course.

† Convoys not originating at Goodfellow AFB will proceed to 16, Veribest Cotton Gin, Make U-Turn and return to 13.

FIGURE 2

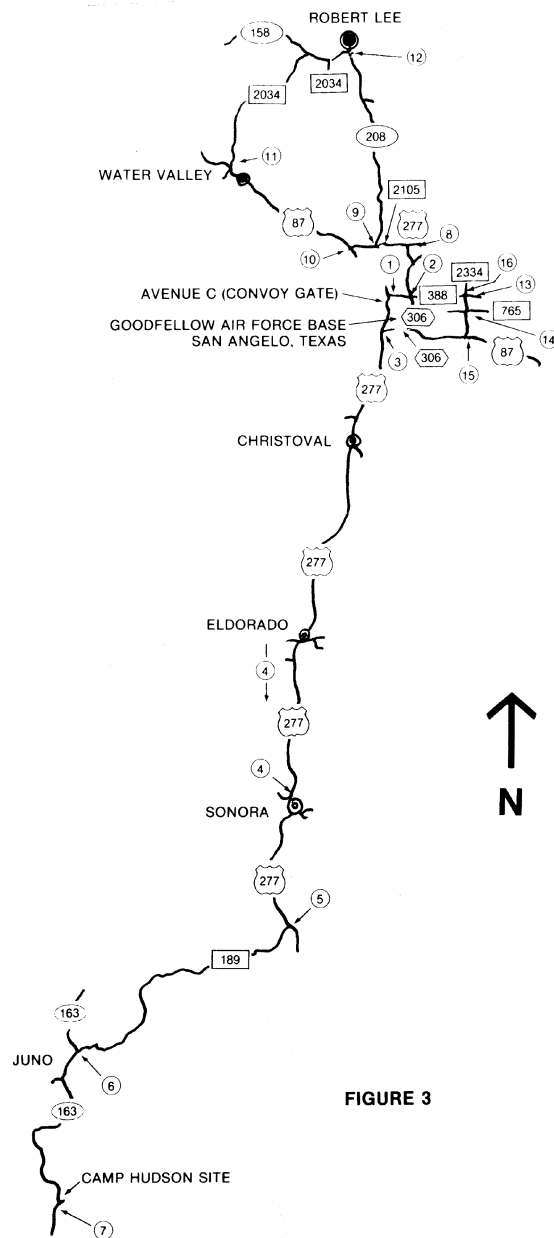


FIGURE 3

APPENDIX B—TRACTION SKID PADS

Two skid pads have been laid on an unused runway and taxi strip on Goodfellow AFB. Their location is shown in Figure 4.

The asphalt skid pad is 600 ft. x 60 ft. and is shown in black on the runway in Figure 4. The pad is approached from either end by a

§ 575.104

49 CFR Ch. V (10-1-10 Edition)

75 ft. ramp followed by 100 ft. of level pavement. This arrangement permits the skid trailers to stabilize before reaching the test area. The approaches are shown on the figure by the hash-marked area.

The concrete pad is 600 ft. x 48 ft. and is on the taxi strip. The approaches to the con-

crete pad are of the same design as those for the asphalt pads.

A two lane asphalt road has been built to connect the runway and taxi strip. The road is parallel to the northeast-southwest runway at a distance of 100 ft. The curves have super-elevation to permit safe exit from the runway at operating speeds.

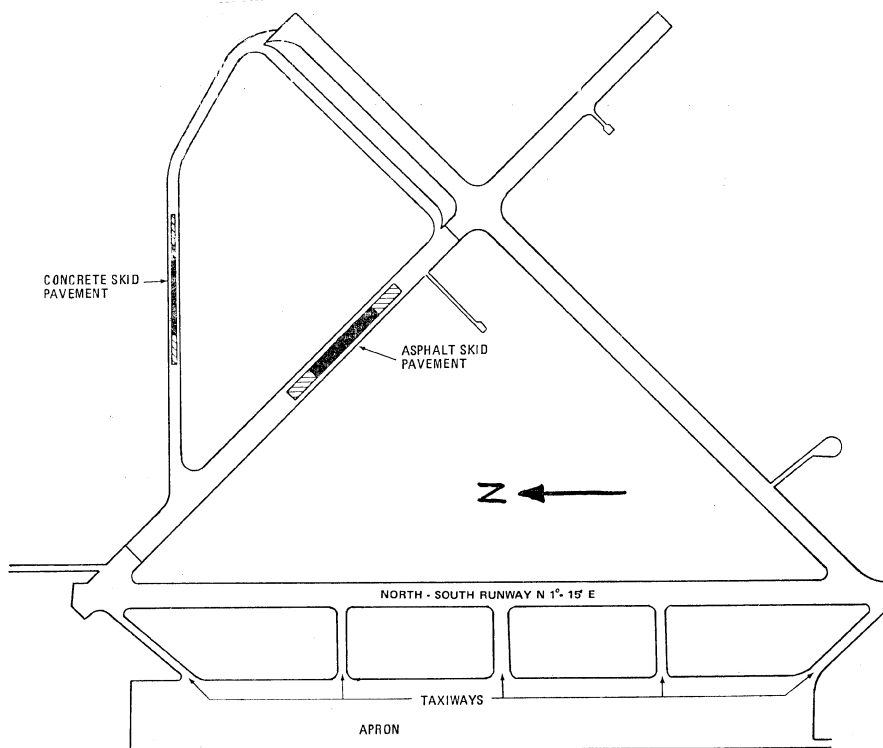


FIGURE 4

APPENDIX C—METHOD OF LEAST SQUARES

The method of least squares is a method of calculation by which it is possible to obtain a reliable estimate of a true physical relationship from a set of data which involve random error. The method may be used to establish a regression line that minimizes the sum of the squares of the deviations of the measured data points from the line. The regression line is consequently described as

the line of "best fit" to the data points. It is described in terms of its slope and its "y" intercept.

The graph in Figure 5 depicts a regression line calculated using the least squares method from data collected from a hypothetical treadwear test of 6,400 miles, with tread depth measurements made at every 500 miles.

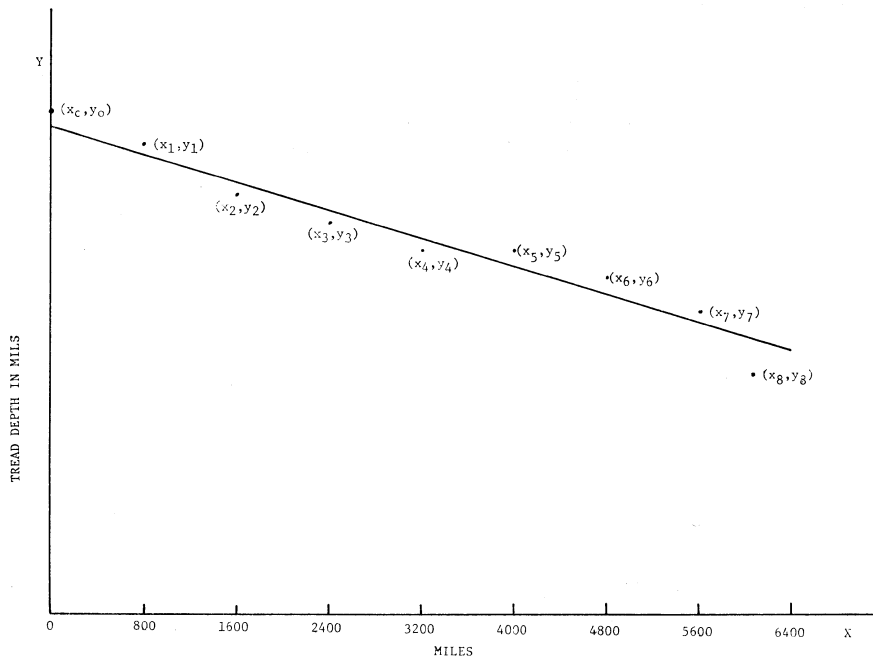


FIGURE 5

In this graph, x_j, Y_j ($j=0, 1, \dots, 8$) are the individual data points representing the tread depth measurements (the overall average for the tire with 6 measurements in each tire groove) at the beginning of the test (after break-in) and at the end of each 800-mile segment of the test.

The absolute value of the slope of the regression line is an expression of the mils of tread worn per 1,000 miles, and is calculated by the following formula:

$$b = 1000 \frac{\left(\sum_{j=0}^8 X_j Y_j - \frac{1}{9} \sum_{j=0}^8 X_j \sum_{j=0}^8 Y_j \right)}{\sum_{j=0}^8 X_j^2 - \frac{1}{9} \left(\sum_{j=0}^8 X_j \right)^2}$$

The "y" intercept of the regression line (a) in mils is calculated by the following formula:

$$a = \frac{1}{9} \sum_{j=0}^8 Y_j - \frac{b}{9000} \sum_{j=0}^8 X_j$$

APPENDIX D—USER FEES

1. *Course Monitoring Tires:* A fee of \$333.00 will be assessed for each course monitoring tire purchased from NHTSA at Goodfellow Air Force Base, San Angelo, Texas. This fee is based upon the direct and indirect costs attributable to: (a) the purchase of course monitoring tires by NHTSA, (b) a pro rata allocation of salaries and general facility costs associated with maintenance of the tires, and (c) warehouse storage fees for the tires.

2. *Use of Government Traction Skid Pads:* A fee of \$34.00 will be assessed for each hour, or fraction thereof, that the traction skid pads at Goodfellow Air Force Base, San Angelo, Texas are used. This fee is based upon the direct and indirect costs attributable to: (a) depreciation on facilities and equipment comprising or used in conjunction with the traction skid pads (i.e., skid system, water truck, air compressor, skid track, tractor sweeper, equipment, buildings), (b) the calibration of the traction skid pads, and (c) a pro rata allocation of salaries and general facility costs associated with maintenance of the traction skid pads.

3. Fee payments shall be by check, draft, money order, or Electronic Funds Transfer

§575.105

System made payable to the Treasurer of the United States.

4. The fees set forth in this appendix continue in effect until adjusted by the Administrator of NHTSA. The Administrator reviews the fees set forth in this appendix and, if appropriate, adjusts them by rule at least every 2 years.

[43 FR 30549, July 17, 1978]

EDITORIAL NOTE: For FEDERAL REGISTER citations affecting §575.104, see the List of CFR Sections Affected, which appears in the Finding Aids section of the printed volume and on GPO Access.

§575.105 Vehicle rollover.

(a) *Purpose and scope.* This section requires manufacturers of utility vehicles to alert the drivers of those vehicles that they have a higher possibility of rollover than other vehicle types and to advise them of steps that can be taken to reduce the possibility of rollover and/or to reduce the likelihood of injury in a rollover.

(b) *Application.* This section applies to utility vehicles.

(c) *Definitions.*

Utility vehicles means multipurpose passenger vehicles (other than those which are passenger car derivatives) which have a wheelbase of 110 inches or less and special features for occasional off-road operation.

(d) *Required information*—(1) *Rollover Warning Label.* (i) Except as provided in paragraph (d)(2) of this section, each vehicle must have a label permanently affixed to either side of the sun visor, at the manufacturer's option, at the driver's seating position. The label must conform in content, form and sequence to the label shown in Figure 1 of this section, and must comply with the following requirements:

(A) The heading area must be yellow, with the text and the alert symbol in black.

(B) The message area must be white with black text.

(C) The pictograms must be black with a white background.

(D) The label must be appropriately sized so that it is legible, visible and prominent to the driver.

(ii) *Vehicles manufactured on or after September 1, 1999 and before September 1, 2000.* When the rollover warning label required by paragraph (d)(1)(i) of this section and the air bag warning label

49 CFR Ch. V (10–1–10 Edition)

required by paragraph S4.5.1(b) of 49 CFR 571.208 are affixed to the same side of the driver side sun visor, either:

(A) The rollover warning label must be affixed to the right (as viewed from the driver's seat) of the air bag warning label and the labels may not be contiguous; or

(B) The pictogram of the air bag warning label must be separated from the pictograms of the rollover warning label by text, and

(1) The labels must be located such that the shortest distance from any of the lettering or graphics on the rollover warning label to any of the lettering or graphics on the air bag warning label is not less than 3 cm, or

(2) If the rollover warning and air bag warning labels are each completely surrounded by a continuous solid-lined border, the shortest distance from the border of the rollover warning label to the border of the air bag warning label is not less than 1 cm.

(iii) The manufacturer must select the option to which a vehicle is certified by the time the manufacturer certifies the vehicle and may not thereafter select a different option for that vehicle. If a manufacturer chooses to certify compliance with more than one compliance option, the vehicle must satisfy the requirements applicable to each of the options selected.

(iv) *Vehicles manufactured on or after September 1, 2000.* When the rollover warning label required by paragraph (d)(1)(i) of this section and the air bag warning label required by paragraph S4.5.1(b) of 49 CFR 571.208 are affixed to the same side of the driver side sun visor the pictogram of the air bag warning label must be separated from the pictograms of the rollover warning label by text and:

(A) The labels must be located such that the shortest distance from any of the lettering or graphics on the rollover warning label to any of the lettering or graphics on the air bag warning label is not less than 3 cm, or

(B) If the rollover warning and air bag warning labels are each completely surrounded by a continuous solid-lined border, the shortest distance from the border of the rollover warning label to the border of the air bag warning label must be not less than 1 cm.

(2) *Alternate location for warning label.* As an alternative to affixing the warning label required by paragraph (d)(1)(i) of this section to the driver's sun visor, a manufacturer may permanently affix the label to the lower rear corner of the forwardmost driver's side window. The label must be legible, visible and prominent to a person next to the exterior of the driver's door.

(3) *Rollover Alert Label.* If the label required by paragraph (d)(1) of this section and affixed to the driver side sun visor is not visible when the sun visor is in the stowed position, an alert label must be permanently affixed to that visor so that the label is visible when the visor is in that position. The alert label must comply with the following requirements:

(i) The label must read:

ROLLOVER WARNING

Flip Visor Over

(ii) The label must be black with yellow text.

(iii) The label must be no less than 20 square cm.

(4) *Owner's Manual.* The owner's manual must include the following statements and discussions:

(i) The statement "Utility vehicles have a significantly higher rollover rate than other types of vehicles."

(ii) A discussion of the vehicle design features which cause this type of vehicles to be more likely to rollover (e.g., higher center of gravity);

(iii) A discussion of the driving practices that can reduce the risk of a rollover (e.g., avoiding sharp turns at excessive speed); and

(iv) The statement: "In a rollover crash, an unbelted person is significantly more likely to die than a person wearing a seat belt."

(5) *Combined Rollover and Air Bag Alert Warning.* If the warnings required by paragraph (d)(1) of this section and paragraph S4.5.1(b) of 49 CFR 571.208 to be affixed to the driver side sun visor are not visible when the sun visor is in the stowed position, a combined rollover and air bag alert label may be permanently affixed to that visor in lieu of the alert labels required by paragraph (d)(3) of this section and paragraph S4.5.1(c)(2) of 49 CFR 571.208. The combined rollover and air bag alert label must be visible when the visor is in the stowed position. The combined rollover and air bag alert warning must conform in content to the label shown in Figure 2 of this section, and must comply with the following requirements:

(i) The label must read:

AIR BAG AND ROLLOVER WARNINGS

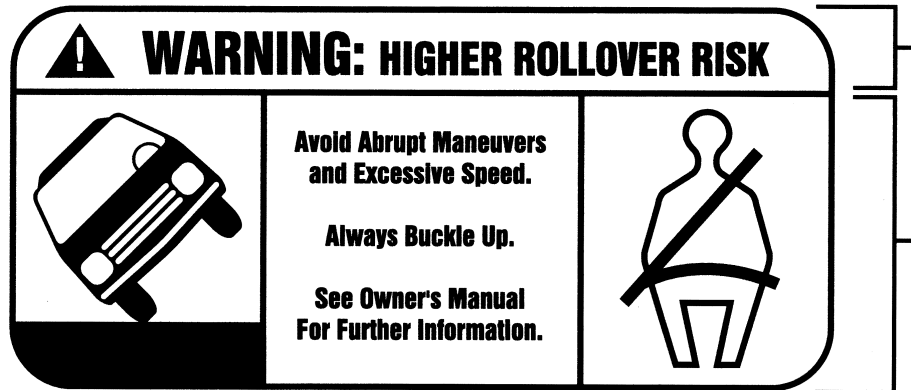
Flip Visor Over

(ii) The message area must be black with yellow text. The message area must be no less than 20 square cm.

(iii) The pictogram shall be black with a red circle and slash on a white background. The pictogram must be not less than 20 mm in diameter.

(6) At the option of the manufacturer, the requirements in paragraph (d)(1)(i) for labels that are permanently affixed to specified parts of the vehicle may instead be met by permanent marking and molding of the required information.

BLACK TEXT ON YELLOW BACKGROUND



ARTWORK AND REMAINING TEXT IN BLACK AND WHITE

FIGURE 1

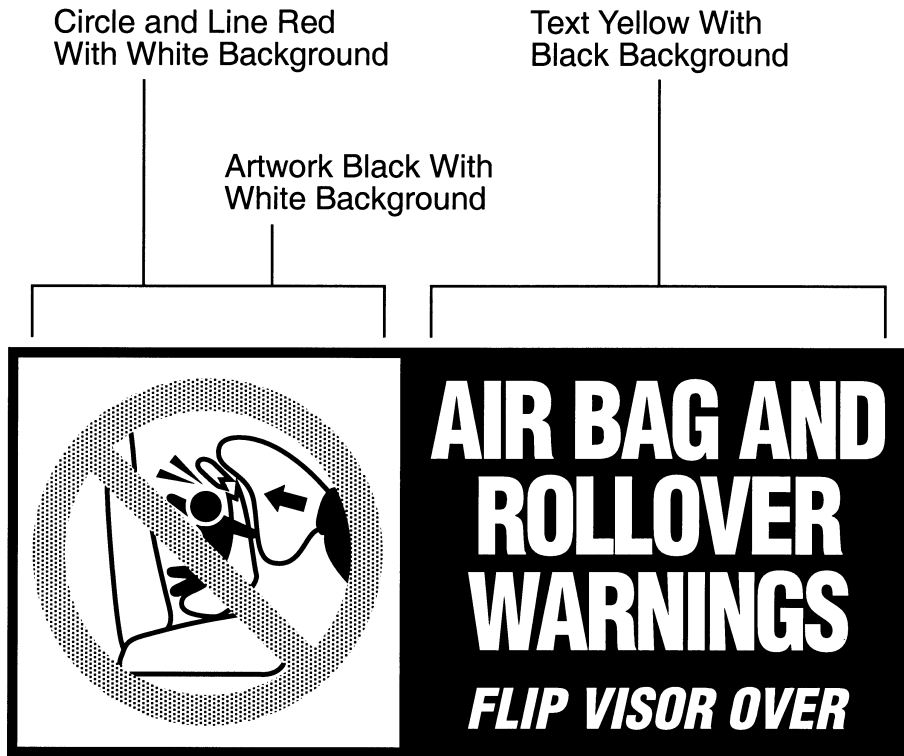


Figure 2. Sun Visor Label Visible When Visor is in Up Position.

[64 FR 11733, Mar. 9, 1999, as amended at 64 FR 47123, Aug. 30, 1999]

§ 575.106 Tire fuel efficiency consumer information program.

(a) *Scope.* This section requires tire manufacturers, tire brand name owners, and tire retailers to provide information indicating the relative performance of replacement passenger car tires in the areas of fuel efficiency, safety, and durability.

(b) *Purpose.* The purpose of this section is to aid consumers in making better educated choices in the purchase of passenger car tires.

(c) *Application.* This section applies to replacement passenger car tires. However, this section does not apply to light truck tires, deep tread, winter-type snow tires, space-saver or temporary use spare tires, tires with nominal rim diameters of 12 inches or less,

or to limited production tires as defined in § 575.104(c)(2). Tire manufacturers may comply with the requirements in this § 575.106 as an alternative to complying with the requirements in § 575.104(d)(1)(i)(A) and (B).

(d) *Definitions.*—(1) All terms used in this section that are defined in Section 32101 of Title 49, United States Code, are used as defined therein.

(2) As used in this section:

Brand name owner means a person, other than a tire manufacturer, who owns or has the right to control the brand name of a tire or a person who licenses another to purchase tires from a tire manufacturer bearing the licensor's brand name.

CT means a pneumatic tire with an inverted flange tire and rim system in which the rim is designed with rim

flanges pointed radially inward and the tire is designed to fit on the underside of the rim in a manner that encloses the rim flanges inside the air cavity of the tire.

Dealer means a person selling and distributing new motor vehicles or motor vehicle equipment primarily to purchasers that in good faith purchase the vehicle or equipment other than for resale.

Distributor means a person primarily selling and distributing motor vehicles or motor vehicle equipment for resale.

Lab alignment tires or *LATs* means the reference tires which the reference lab will test to be used to align other rolling resistance machines with the reference lab in accordance with the machine alignment procedure in ISO 28580 (incorporated by reference, *see* §575.3), section 10.

Light truck (LT) tire means a tire designated by its manufacturer as primarily intended for use on lightweight trucks or multipurpose passenger vehicles.

Passenger car tire means a tire intended for use on passenger cars, multipurpose passenger vehicles, and trucks, that have a gross vehicle weight rating (GVWR) of 10,000 pounds or less.

Reference lab means the laboratory or laboratories that the National Highway Traffic Safety Administration designates and which maintains and operates a rolling resistance test machine to test LATs for rolling resistance so that other testing laboratories may correlate the results from its rolling resistance test machine in accordance with the machine alignment procedure in ISO 28580 (incorporated by reference, *see* §575.3), section 10.

Replacement passenger car tire means any passenger car tire other than a passenger car tire sold as original equipment on a new vehicle.

Size designation means the alpha-numeric designation assigned by a manufacturer that identifies a tire's size. This can include identifications of tire class, nominal width, aspect ratio, tire construction, and wheel diameter.

Stock keeping unit or *SKU* means the alpha-numeric designation assigned by a manufacturer to uniquely identify a tire product. This term is sometimes

referred to as a product code, a product identifier, or a part number.

Tire line or *tire model* means the entire name used by a tire manufacturer to designate a tire product, including all prefixes and suffixes as they appear on the sidewall of a tire.

Tire retailer means a dealer or distributor of new replacement passenger car tires sold for use on passenger cars, multipurpose passenger vehicles, and trucks, that have a gross vehicle weight rating (GVWR) of 10,000 pounds or less.

(e) *Requirements.*—(1) *Information.* (i) *Requirements for tire manufacturers.* Subject to paragraph (e)(1)(iii) of this section, each manufacturer of tires, or in the case of tires marketed under a brand name, each brand name owner shall provide rating information for each tire of which it is the manufacturer or brand name owner in the manner set forth in paragraphs (e)(1)(i)(A) through (C) of this section. The ratings for each tire shall be only those specified in paragraph (e)(2) of this section. For the purposes of this section, each tire of a different SKU is to be rated separately. Each tire shall be able to achieve the level of performance represented by each rating.

(A) *Ratings.* Each tire shall be rated with the words, letters, symbols, and figures specified in paragraph (e)(2) of this section.

(B) *Tire label.* [Reserved]

(C) *Reporting requirements.* The information collection requirements contained in this section have been approved by the Office of Management and Budget under the provisions of the Paperwork Reduction Act (44 U.S.C. 3501 *et seq.*) and are awaiting an assigned OMB Control Number.

(I) Subject to paragraph (e)(1)(iii) of this section, manufacturers of tires or, in the case of tires marketed under a brand name, brand name owners of tires subject to this section shall submit to NHTSA electronically, either directly or through an agent, the following data for each rated replacement passenger car tire:

(i) Rolling resistance rating, as determined in paragraph (e)(2)(i) of this section.

(ii) Wet traction rating, as determined in paragraph (e)(2)(ii) of this section.

(iii) Treadwear rating, as determined in paragraph (e)(2)(iii) of this section.

(2) *Format of data submitted.* The information required under paragraph (e)(1)(i)(C)(I) of this section shall be submitted to NHTSA as extra columns in the electronic data submission required under section 26 of Part 579.

(3) *Exempted tires.* Manufacturers of tires or, in the case of tires marketed under a brand name, brand name owners of tires subject to this section shall submit to NHTSA all tire lines, size designations, and stock keeping units it manufactures which are exempted from this section (§575.106) as determined under paragraph (c) of this section. Where a manufacturer is required to report ratings under this section, the information required in this paragraph may be submitted with the ratings information reported in accordance with paragraph (e)(1)(i)(C)(I) of this section. Where a manufacturer of tires, or in the case of tires marketed under a brand name, brand name owners of tires only manufactures tires that are exempt from this section under paragraph (c) of this section, that manufacturer shall submit a one-time statement listing the tire lines, size designations, and stock keeping units it manufactures, and certifying that none of the tires it manufactures are required to be rated under this section.

(4) *New ratings information.* Whenever the tire manufacturer, or in the case of tires marketed under a brand name, the brand name owner receives information that would determine new or different information required under paragraph (e)(1)(i)(C)(I) of this section for a tire, the tire manufacturer or brand name owner shall submit the new ratings information to NHTSA on or before the date 30 calendar days after receipt by the manufacturer or brand name owner of the new information, whichever comes first.

(5) *Voluntary submission of data.* Manufacturers of tires or, in the case of tires marketed under a brand name, brand name owners of tires not subject to this section may submit to NHTSA data meeting the requirements of para-

graphs (e)(1) and (2) of this section for any tire they wish to have included in the database of information available to consumers on NHTSA's Web site.

(ii) *Requirements for tire retailers.* Subject to paragraph (e)(1)(iii) of this section, each tire retailer shall provide rating information for each passenger car tire offered for sale in the manner set forth in this section.

(iii) *Date for compliance.* The requirements of paragraphs (e)(1)(i) and (e)(1)(ii) of this section will be implemented as indicated in a forthcoming final rule. These dates will be announced in the FEDERAL REGISTER.

(2) *Performance.*—(i) *Fuel efficiency.* [Reserved]

(ii) *Traction.* [Reserved]

(iii) *Treadwear.* [Reserved]

(f) *Fuel efficiency rating conditions and procedures.*—(1) *Conditions.* (i) Measurement of rolling resistance force under the test procedure specified in paragraph (f)(2) of this section shall be made using either the force or the torque method.

(ii) The test procedure specified in paragraph (f)(2) of this section shall be carried out on an 80-grit roadwheel surface.

(iii) The machine alignment procedure specified in section 10 of the test procedure specified in paragraph (f)(2) of this section shall be conducted using pairs of the LATs specified in paragraph (f)(1)(iv) of this section, and tested by the reference lab.

(iv) *Lab alignment tires.* The LATs to be used in the machine alignment procedure in section 10 of the test procedure specified in paragraph (f)(2) of this section will be specified in this section in a forthcoming final rule.

(v) *Break-in procedure for bias ply tires.* Before starting the rolling resistance testing under the test procedure specified in paragraph (f)(2) of this section on a bias ply replacement passenger car tire, the tire shall be broken in by running it for one (1) hour with the speed, loading, and inflation pressure as specified in paragraphs (f)(1)(v)(A), (f)(1)(v)(B), and (f)(1)(v)(C) of this section. After the one hour break-in, allow the tire to cool for two (2) hours and re-adjust to the required ISO 28580 (incorporated by reference, see §575.3) test

§575.106

49 CFR Ch. V (10–1–10 Edition)

inflation pressure, and verify 10 minutes after the adjustment is made. After break-in, the bias ply tire should follow the 30 minute warm-up procedure of ISO 28580 (incorporated by reference, *see* §575.3).

(A) *Speed.* The speed shall be 80 kilometer per hour (kph).

(B) *Loading.* The tire loading shall be 80 percent of the maximum tire load capacity.

(C) *Inflation pressure.* The inflation pressure shall be 210 kilopascals (kPa) for standard load tires, or 250 kPa for reinforced or extra load tires.

(2) *Procedure.* The test procedure shall be as specified in ISO 28580 (incorporated by reference, *see* §575.3), except that the conditions specified in paragraph (f)(1) of this section shall be used.

(g) *Traction rating conditions and procedures.* (1) *Conditions.* Test conditions are as specified in §575.104(f)(1), subject to the changes in paragraphs (g)(1)(i) through (g)(1)(iii) of this section to additionally measure the peak coefficient of friction.

(i) The sampling rate of the data acquisition is to be no less than 100 Hertz in accordance with Section 6.6.1.8 of ASTM E 1337 (incorporated by reference, *see* §575.3).

(ii) The rate of brake application shall be sufficient to control the time interval between initial brake application and peak longitudinal force to be between 0.3 and 0.5 seconds, and shall be determined in accordance with Section 6.3.2 of ASTM E 1337 (incorporated by reference, *see* §575.3).

(iii) The peak coefficient of friction (or peak braking coefficient) shall be determined in accordance with Section 12 of ASTM E 1337 (incorporated by reference, *see* §575.3) for each dataset.

(iv) The slide coefficient of friction will be determined in accordance with §575.104(f)(2)(iii).

(2) *Procedure.* (i) Prepare two standard tires as specified in §575.104(f)(2)(i).

(ii) Mount the tires on the test apparatus described in §575.104(f)(1)(iv) and load each tire to 1,085 pounds.

(iii) Tow the trailer on the asphalt test surface specified in §575.104(f)(1)(i) at a speed of 40 mph, lock one trailer wheel, and record the slide and peak

coefficient of friction on the tire associated with that wheel.

(iv) Repeat the test on the concrete surface, locking the same wheel.

(v) Repeat the tests specified in paragraphs (g)(2)(iii) and (iv) of this section for a total of 10 measurements on each test surface.

(vi) Repeat the procedures specified in paragraphs (g)(2)(iii) through (v) of this section, locking the wheel associated with the other standard tire.

(vii) Average the 20 measurements taken on the asphalt surface to find the standard tire average peak coefficient of friction for the asphalt surface. Average the 20 measurements taken on the concrete surface to find the standard tire average peak coefficient of friction for the concrete surface. The standard tire average peak coefficient of friction so determined may be used in the computation of adjusted peak coefficients of friction for more than one candidate tire.

(viii) Average the 20 measurements taken on the asphalt surface to find the standard tire average slide coefficient of friction for the asphalt surface. Average the 20 measurements taken on the concrete surface to find the standard tire average slide coefficient of friction for the concrete surface. The standard tire average slide coefficient of friction so determined may be used in the computation of adjusted slide coefficients of friction for more than one candidate tire.

(ix) Prepare two candidate tires of the same SKU in accordance with paragraph (g)(2)(i) of this section, mount them on the test apparatus, and test one of them according to the procedures of paragraphs (g)(2)(ii) through (v) of this section, except load each tire to 85 percent of the test load specified in §575.104(h). For CT tires, the test inflation of candidate tires shall be 230 kPa. Candidate tire measurements may be taken either before or after the standard tire measurements used to compute the standard tire traction coefficient. Take all standard tire and candidate tire measurements used in computation of a candidate tire's adjusted peak coefficient and adjusted slide coefficient of friction within a single three-hour period. Average the 10 measurements taken on the asphalt

surface to find the candidate tire average peak coefficient and average slide coefficient of friction for the asphalt surface. Average the 10 measurements taken on the concrete surface to find the candidate tire average peak coefficient of friction for the concrete surface. Average the 10 measurements taken on the concrete surface to find the candidate tire average slide coefficient of friction for the concrete surface.

(x) Repeat the procedures specified in paragraph (g)(2)(viii) of this section, using the second candidate tire as the tire being tested.

(h) *Treadwear rating conditions and procedures.*—(1) *Conditions.* Test conditions are as specified in § 575.104(e)(1).

(2) *Procedure.* Test procedure is as specified in § 575.104(e)(2).

[75 FR 15944, Mar. 30, 2010]

Subpart C—Transportation Recall Enhancement, Accountability, and Documentation Act; Consumer Information

§ 575.201 Child restraint performance.

The National Highway Traffic Safety Administration has established a program for rating the performance of child restraints. The agency makes the information developed under this rating program available through a variety of means, including postings on its Web site, <http://www.nhtsa.dot.gov>.

[67 FR 67494, Nov. 5, 2002]

Subpart D—Safe, Accountable, Flexible, Efficient Transportation Equity Act: A Legacy for Users (SAFETEA-LU); Consumer Information

SOURCE: 71 FR 53585, Sept. 12, 2006, unless otherwise noted.

§ 575.301 Vehicle Labeling of Safety Rating Information.

(a) *Purpose and Scope.* The purpose of this section is to aid potential purchasers in the selection of new passenger motor vehicles by providing them with safety rating information developed by NHTSA in its New Car Assessment Program (NCAP) testing.

Manufacturers of passenger motor vehicles described in paragraph (b) of this section are required to include this information on the Monroney label. Although NHTSA also makes the information available through means such as postings at <http://www.safercar.gov> and <http://www.nhtsa.dot.gov>, the additional Monroney label information is intended to provide consumers with relevant information at the point of sale.

(b) *Application.* This section applies to automobiles with a GVWR of 10,000 pounds or less, manufactured on or after September 1, 2007, that are required by the Automobile Information Disclosure Act, 15 U.S.C. 1231–1233, to have price sticker labels (Monroney labels), e.g., passenger vehicles, station wagons, passenger vans, and sport utility vehicles.

(c) *Definitions.* (1) *Monroney label* means the label placed on new automobiles with the manufacturer's suggested retail price and other consumer information, as specified at 15 U.S.C. 1231–1233.

(2) *Safety rating label* means the label with NCAP safety rating information, as specified at 15 U.S.C. 1232(g). The safety rating label is part of the Monroney label.

(d) *Required Label.* (1) Except as specified in paragraph (f) of this section, each vehicle must have a safety rating label that is part of its Monroney label, meets the requirements specified in paragraph (e) of this section, and conforms in content, format and sequence to the sample label depicted in Figure 1 of this section. If NHTSA has not provided a safety rating for any category of vehicle performance for a vehicle, the manufacturer may use the smaller label specified in paragraph (f) of this section.

(2) The label must depict the star ratings for that vehicle as reported to the vehicle manufacturer by NHTSA.

(3) Whenever NHTSA informs a manufacturer in writing of a new safety rating for a specified vehicle or the continued applicability of an existing

safety rating for a new model year, including any safety concerns, the manufacturer shall include the new or continued safety rating on vehicles manufactured on or after the date 30 calendar days after receipt by the manufacturer of the information.

(4) If, for a vehicle that has an existing safety rating for a category, NHTSA informs the manufacturer in writing that it has approved an optional NCAP test that will cover that category, the manufacturer may depict vehicles manufactured on or after the date of receipt of the information as “Not Rated” or “To Be Rated” for that category.

(5) The text “Frontal Crash,” “Side Crash,” “Rollover,” “Driver,” “Passenger,” “Front Seat,” “Rear Seat” and where applicable, “Not Rated” or “To Be Rated,” the star graphic indicating each rating, as well as any text in the header and footer areas of the label, must have a minimum font size of 12 point. All remaining text and symbols on the label (including the star graphic specified in paragraph (e)(8)(i)(A) of this section, must have a minimum font size of 8 point.

(e) *Required Information and Format*—

(1) *Safety Rating Label Border.* The safety rating label must be surrounded by a solid dark line that is a minimum of 3 points in width.

(2) *Safety Rating Label Size and Legibility.* The safety rating label must be presented in a legible, visible, and prominent fashion that covers at least 8 percent of the total area of the Monroney label (*i.e.*, including the safety rating label) or an area with a minimum of 4½ inches in length and 3½ inches in height on the Monroney label, whichever is larger.

(3) *Heading Area.* The words “Government Safety Ratings” must be in boldface, capital letters that are light in color and centered. The background must be dark.

(4) *Frontal Crash Area.* (i) The frontal crash area must be placed immediately below the heading area and must have dark text and a light background. Both the driver and the right front passenger frontal crash test ratings must be displayed with the maximum star ratings achieved.

(ii) The words “Frontal Crash” must be in boldface, cover two lines, and be aligned to the left side of the label.

(iii) The word “Driver” must be on the same line as the word “Frontal” in “Frontal Crash,” and be left justified, horizontally centered and vertically aligned at the top of the label. The achieved star rating for “Driver” must be on the same line, left justified, and aligned to the right side of the label.

(iv) If NHTSA has not released the star rating for the “Driver” position, the text “Not Rated” must be used in boldface. However, as an alternative, the words “To Be Rated” (in boldface) may be used if the manufacturer has received written notification from NHTSA that the vehicle has been chosen for NCAP testing. Both texts must be on the same line as the text “Driver”, left justified, and aligned to the right side of the label.

(v) The word “Passenger” must be on the same line as the word “Crash” in “Frontal Crash,” below the word “Driver,” and be left justified, horizontally centered and vertically aligned at the top of the label. The achieved star rating for “Passenger” must be on the same line, left justified, and aligned to the right side of the label.

(vi) If NHTSA has not released the star rating for “Passenger,” the words “Not Rated” must be used in boldface. However, as an alternative, the words “To Be Rated” (in boldface) may be used if the manufacturer has received written notification from NHTSA that the vehicle has been chosen for NCAP testing. Both texts must be on the same line as the text “Passenger”, left justified, and aligned to the right side of the label.

(vii) The words “Star ratings based on the risk of injury in a frontal impact.”, followed (on the next line) by the statement “Frontal ratings should ONLY be compared to other vehicles of similar size and weight.” must be placed at the bottom of the frontal crash area.

(5) *Side Crash Area.* (i) The side crash area must be immediately below the frontal crash area, separated by a dark line that is a minimum of three points in width. The text must be dark against a light background. Both the

driver and the rear seat passenger side crash test rating must be displayed with the maximum star rating achieved.

(ii) The words "Side Crash" must cover two lines, and be aligned to the left side of the label in boldface.

(iii) The words "Front seat" must be on the same line as the word "Side" in "Side Crash" and be left justified, horizontally centered and vertically aligned in the middle of the label. The achieved star rating for "Front seat" must be on the same line, left justified, and aligned to the right side of the label.

(iv) If NHTSA has not released the star rating for "Front Seat," the words "Not Rated" must be used in boldface. However, as an alternative, the words "To Be Rated" (in boldface) may be used if the manufacturer has received written notification from NHTSA that the vehicle has been chosen for NCAP testing. Both texts must be on the same line as the text "Front seat", left justified, and aligned to the right side of the label.

(v) The words "Rear seat" must be on the same line as the word "Crash" in "Side Crash," below the word "Front seat," and be left justified, horizontally centered and vertically aligned in the middle of the label. The achieved star rating for "Rear seat" must be on the same line, left justified, and aligned to the right side of the label.

(vi) If NHTSA has not released the star rating for "Rear Seat," the text "Not Rated" must be used in boldface. However, as an alternative, the text "To Be Rated" (in boldface) may be used if the manufacturer has received written notification from NHTSA that the vehicle has been chosen for NCAP testing. Both texts must be on the same line as the text "Rear seat", left justified, and aligned to the right side of the label.

(vii) The words: "Star ratings based on the risk of injury in a side impact," must be placed at the bottom of the side crash area.

(6) *Rollover Area.* (i) The rollover area must be immediately below the side crash area, separated by a dark line that is a minimum of three points in width. The text must be dark against a

light background. The rollover test rating must be displayed with the maximum star rating achieved.

(ii) The word "Rollover" must be aligned to the left side of the label in boldface. The achieved star rating must be on the same line, aligned to the right side of the label.

(iii) If NHTSA has not tested the vehicle, the words "Not Rated" must be used in boldface. However, as an alternative, the words "To Be Rated" (in boldface) may be used if the manufacturer has received written notification from NHTSA that the vehicle has been chosen for NCAP testing. Both texts must be on the same line as the text "Rollover", left justified, and aligned to the right side of the label.

(iv) The words: "Star ratings based on the risk of rollover in a single vehicle crash," must be placed at the bottom of the rollover area.

(7) *Graphics.* The star graphic is depicted in Figure 3 and the safety concern graphic is depicted in Figure 4.

(8) *General Information Area.* (i) The general information area must be immediately below the rollover area, separated by a dark line that is a minimum of three points in width. The text must be dark and the background must be light. The text must state the following, in the specified order, on separate lines:

(A) "Star ratings range from 1 to 5 stars (★★★★★), with 5 being the highest," and

(B) "Source: National Highway Traffic Safety Administration (NHTSA)"

(9) *Footer Area.* The text "www.safercar.gov or 1-888-327-4236" must be provided in boldface letters that are light in color, and be centered. The background must be dark.

(10) *Safety Concern.* For vehicle tests for which NHTSA reports a safety concern as part of the star rating, the label must:

(i) Depict, as a superscript to the star rating, the related symbol, as depicted in Figure 4 of this section, at $\frac{2}{3}$ the font size of the base star, and

(ii) Include at the bottom of the relevant area (i.e., frontal crash area, side crash area, rollover area), as the last line of that area, the related symbol, as depicted in Figure 4 of this section, as a superscript of the rest of the line, and

§ 575.301

49 CFR Ch. V (10–1–10 Edition)

the text “Safety Concern: Visit *www.safercar.gov* or call 1-888-327-4236 for more details.”

(11) No additional information may be provided in the safety rating label area. The specified information provided in a language other than English is not considered to be additional information.

(f) *Smaller Safety Rating Label for Vehicles with No Ratings.* (1) If NHTSA has not released a safety rating for any category for a vehicle, the manufacturer may use a smaller safety rating label that meets paragraphs (f)(2) through (f)(5) of this section. A sample label is depicted in Figure 2.

(2) The label must be at least 4½ inches in width and 1½ inches in height, and must be surrounded by a solid dark line that is a minimum of 3 points in width.

(3) *Heading Area.* The text must read “Government Safety Ratings” and be in 14-point boldface, capital letters that are light in color, and be centered. The background must be dark.

(4) *General Information.* The general information area must be below the header area. The text must be dark and the background must be light. The text must state the following, in at least 12-point font, be left-justified, and aligned to the left side of the label, in the specified order:

(i) “This vehicle has not been rated by the government for frontal crash, side crash, or rollover risk.”

(ii) “Source: National Highway Traffic Safety Administration (NHTSA).”

(5) *Footer Area.* The text “*www.safercar.gov* or 1-888-327-4236” must be provided in 14-point boldface letters that are light in color, and be centered. The background must be dark.

(6) No additional information may be provided in the smaller safety rating label area. The specified information provided in a language other than English is not considered to be additional information.

(g) *Labels for alterers.* (1) If, pursuant to 49 CFR 567.7, a person is required to affix a certification label to a vehicle, and the vehicle has a safety rating label with one or more safety ratings, the alterer must also place another label on that vehicle as specified in this paragraph.

(2) The additional label (which does not replace the one required by 49 CFR 567.7) must read: “This vehicle has been altered. The stated star ratings on the safety rating label may no longer be applicable.”

(3) The label must be placed adjacent to the Monroney label or as close to it as physically possible.

Figure 1 to Sec. 575.301
Sample Label for a Vehicle with At Least One NCAP Rating

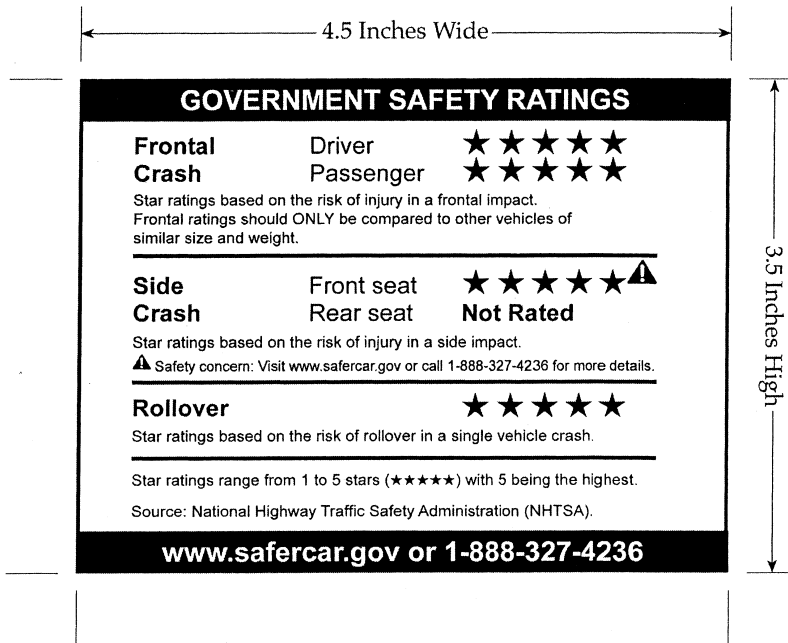


Figure 2 to Sec. 575.301
Sample Label for a Vehicle with No NCAP Ratings

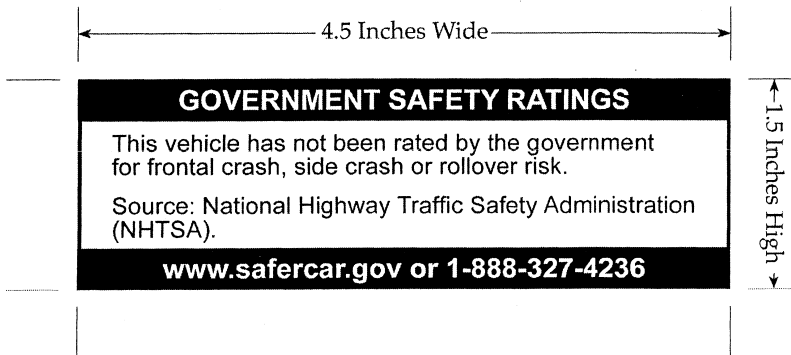


Figure 3 to Sec. 575.301
Sample Star Rating Graphic for Sec. 575.301



Figure 4 to Sec. 575.301
Sample Safety Concern Graphic for Sec. 575.301



[71 FR 53585, Sept. 12, 2006, as amended at 72 FR 45176, Aug. 13, 2007]

PART 576—RECORD RETENTION

- Sec.
- 576.1 Scope.
- 576.2 Purpose.
- 576.3 Application.
- 576.4 Definitions.
- 576.5 Basic requirements.
- 576.6 Records.
- 576.7 Retention.
- 576.8 Malfunctions covered.

AUTHORITY: 49 U.S.C. 322(a), 30117, 30120(g), 30141–30147; delegation of authority at 49 CFR 1.50.

SOURCE: 39 FR 30045, Aug. 20, 1974, unless otherwise noted.

EDITORIAL NOTE: For an interpretation document regarding part 576, see 40 FR 3296, Jan. 21, 1975.

§ 576.1 Scope.

This part establishes requirements for the retention by manufacturers of motor vehicles and of motor vehicle equipment, of claims, complaints, reports, and other records concerning alleged and proven motor vehicle or motor vehicle equipment defects and

malfunctions that may be related to motor vehicle safety.

[67 FR 45872, July 10, 2002]

§ 576.2 Purpose.

The purpose of this part is to preserve records that are needed for the proper investigation, and adjudication or other disposition, of possible defects related to motor vehicle safety and instances of nonconformity to the motor vehicle safety standards and associated regulations.

§ 576.3 Application.

This part applies to all manufacturers of motor vehicles, with respect to all records generated or acquired on or after August 16, 1969, and to all manufacturers of motor vehicle equipment, with respect to all records in their possession, generated or acquired on or after August 9, 2002.

[67 FR 45873, July 10, 2002]

§ 576.4 Definitions.

All terms in this part that are defined in 49 U.S.C. 30102 and part 579 of this chapter are used as defined therein.

[67 FR 45873, July 10, 2002]

§ 576.5 Basic requirements.

(a) Each manufacturer of motor vehicles, child restraint systems, and tires shall retain, as specified in § 576.7 of this part, all records described in § 576.6 of this part for a period of five calendar years from the date on which they were generated or acquired by the manufacturer.

(b) Each manufacturer of motor vehicles and motor vehicle equipment shall retain, as specified in § 576.7 of this part, all the underlying records on which the information reported under part 579 of this chapter is based, for a period of five calendar years from the date on which they were generated or acquired by the manufacturer, except as provided in paragraph (c) of this section.

(c) Manufacturers need not retain copies of documents transmitted to NHTSA pursuant to parts 573, 577, and 579 of this chapter.

[67 FR 45873, July 10, 2002]

§ 576.6 Records.

Records to be maintained by manufacturers under this part include all documentary materials, films, tapes, and other information-storing media that contain information concerning malfunctions that may be related to motor vehicle safety. Such records include, but are not limited to, reports and other documents, including material generated or communicated by computer, telefax or other electronic means, that are related to work performed under warranties; and any lists, compilations, analyses, or discussions of such malfunctions contained in internal or external correspondence of the manufacturer, including communications transmitted electronically.

[67 FR 45873, July 10, 2002]

§ 576.7 Retention.

Duplicate copies need not be retained. Information may be reproduced or transferred from one storage medium to another (e.g., from paper files to microfilm) as long as no information is lost in the reproduction or transfer, and when so reproduced or transferred the original form may be treated as a duplicate.

§ 576.8 Malfunctions covered.

For purposes of this part, “malfunctions that may be related to motor vehicle safety” shall include, with respect to a motor vehicle or item of motor vehicle equipment, any failure or malfunction beyond normal deterioration in use, or any failure of performance, or any flaw or unintended deviation from design specifications, that could in any reasonably foreseeable manner be a causative factor in, or aggravate, an accident or an injury to a person.

PART 577—DEFECT AND NONCOMPLIANCE NOTIFICATION

- Sec.
- 577.1 Scope.
- 577.2 Purpose.
- 577.3 Application.
- 577.4 Definitions.
- 577.5 Notification pursuant to a manufacturer's decision.
- 577.6 Notification pursuant to Administrator's decision.
- 577.7 Time and manner of notification.
- 577.8 Disclaimers.
- 577.9 Conformity to statutory requirements.
- 577.10 Follow-up notification.
- 577.11 Reimbursement notification.
- 577.12 Notification pursuant to an accelerated remedy program.
- 577.13 Notification to dealers and distributors.

AUTHORITY: 49 U.S.C. 30102, 30103, 30116-30121, 30166; delegations of authority at 49 CFR 1.50 and 49 CFR 501.8.

SOURCE: 41 FR 56816, Dec. 30, 1976, unless otherwise noted.

§ 577.1 Scope.

This part sets forth requirements for manufacturer notification to owners, dealers, and distributors of motor vehicles and items of replacement equipment about a defect that relates to motor vehicle safety or a noncompliance with a Federal motor vehicle safety standard.

[69 FR 34959, June 23, 2004]

§ 577.2 Purpose.

The purpose of this part is to ensure that notifications of defects or noncompliances adequately inform and effectively motivate owners of potentially defective or noncomplying motor

§ 577.3

vehicles or items of replacement equipment to have such vehicles or equipment inspected and, where necessary, remedied as quickly as possible. It is also to ensure that dealers and distributors of motor vehicles and items of replacement equipment are made aware of the existence of defects and noncompliances and of their rights and responsibilities with regard thereto.

[41 FR 56816, Dec. 30, 1976, as amended at 69 FR 34959, June 23, 2004]

§ 577.3 Application.

This part applies to manufacturers of complete motor vehicles, incomplete motor vehicles, and replacement equipment. In the case of vehicles manufactured in two or more stages, compliance by either the manufacturer of the incomplete vehicle, any subsequent manufacturer, or the manufacturer of affected replacement equipment, shall be considered compliance by each of those manufacturers.

§ 577.4 Definitions.

For the purposes of this part:

Act means 49 U.S.C. Chapter 30101–30169.

Administrator means the Administrator of the National Highway Traffic Safety Administration or his delegate.

First purchaser means the first purchaser in good faith for a purpose other than resale.

Leased motor vehicle means any motor vehicle that is leased to a person for a term of at least four months by a lessor who has leased five or more vehicles in the twelve months preceding the date of notification by the vehicle manufacturer of the existence of a safety-related defect or noncompliance with a Federal motor vehicle safety standard in the motor vehicle.

Lessee means a person who is the lessee of a leased motor vehicle as defined in this section.

Lessor means a person or entity that is the owner, as reflected on the vehicle's title, of any five or more leased vehicles (as defined in this section), as of the date of notification by the manufacturer of the existence of a safety-related defect or noncompliance with a Federal motor vehicle safety standard in one or more of the leased motor vehicles.

49 CFR Ch. V (10–1–10 Edition)

Owners includes purchaser.

[41 FR 56816, Dec. 30, 1976, as amended at 60 FR 17270, Apr. 5, 1995]

§ 577.5 Notification pursuant to a manufacturer's decision.

(a) When a manufacturer of motor vehicles or replacement equipment determines that any motor vehicle or item of replacement equipment produced by the manufacturer contains a defect that relates to motor vehicle safety, or fails to conform to an applicable Federal motor vehicle safety standard, the manufacturer shall provide notification in accordance with paragraph (a) of § 577.7, unless the manufacturer is exempted by the Administrator (pursuant to 49 U.S.C. 30118(d) or 30120(h)) from giving such notification. The notification shall contain the information specified in this section. The information required by paragraphs (b) and (c) of this section shall be presented in the form and order specified. The information required by paragraphs (d) through (h) of this section may be presented in any order. Except as authorized by the Administrator, the manufacturer shall submit a copy of its proposed owner notification letter, including any provisions or attachments related to reimbursement, to NHTSA's Recall Management Division (NVS-215) no fewer than five Federal Government business days before it intends to begin mailing it to owners. The manufacturer shall mark the outside of each envelope in which it sends an owner notification letter with a notation that includes the words "SAFETY," "RECALL," and "NOTICE," all in capital letters and in type that is larger than that used in the address section, and is also distinguishable from the other type in a manner other than size. Except where the format of the envelope has been previously approved by NHTSA's Recall Management Division (NVS-215), each manufacturer must submit the envelope format it intends to use to that division at least five Federal Government business days before mailing the notification to owners. Submission of envelopes and proposed owner notification letters shall be made by any means, including those means identified in 49 CFR 573.9, that

permits the manufacturer to verify receipt promptly by the Recall Management Division and the date it was received by that division. Notification sent to an owner whose address is in either the Commonwealth of Puerto Rico or the Canal Zone shall be written in both English and Spanish.

(b) An opening statement: "This notice is sent to you in accordance with the requirements of the National Traffic and Motor Vehicle Safety Act."

(c) Whichever of the following statements is appropriate:

(1) "(Manufacturer's name or division) has decided that a defect which relates to motor vehicle safety exists in (identified motor vehicles, in the case of notification sent by a motor vehicle manufacturer; identified replacement equipment, in the case of notification sent by a replacement equipment manufacturer);" or

(2) "(Manufacturer's name or division) has decided that (identified motor vehicles, in the case of notification sent by a motor vehicle manufacturer; identified replacement equipment, in the case of notification sent by a replacement equipment manufacturer) fail to conform to Federal Motor Vehicle Safety Standard No. (number and title of standard)."

(d) When the manufacturer determines that the defect or noncompliance may not exist in each such vehicle or item of replacement equipment, he may include an additional statement to that effect.

(e) A clear description of the defect or noncompliance, which shall include—

(1) An identification of the vehicle system or particular item(s) of motor vehicle equipment affected.

(2) A description of the malfunction that may occur as a result of the defect or noncompliance. The description of a noncompliance with an applicable standard shall include, in general terms, the difference between the performance of the noncomplying vehicle or item of replacement equipment and the performance specified by the standard;

(3) A statement of any operating or other conditions that may cause the malfunction to occur; and

(4) A statement of the precautions, if any, that the owners should take to reduce the chance that the malfunction will occur before the defect or noncompliance is remedied.

(f) An evaluation of the risk to motor vehicle safety reasonably related to the defect or noncompliance.

(1) When vehicle crash is a potential occurrence, the evaluation shall include whichever of the following is appropriate:

(i) A statement that the defect or noncompliance can cause vehicle crash without prior warning; or

(ii) A description of whatever prior warning may occur, and a statement that if this warning is not heeded, vehicle crash can occur.

(2) When vehicle crash is not the potential occurrence, the evaluation must include a statement indicating the general type of injury to occupants of the vehicle, or to persons outside the vehicle, that can result from the defect or noncompliance, and a description of whatever prior warning may occur.

(g) A statement of measures to be taken to remedy the defect or noncompliance, in accordance with paragraph (g)(1) or (g)(2) of this section, whichever is appropriate.

(1) When the manufacturer is required by the Act to remedy the defect or noncompliance without charge, or when he will voluntarily so remedy in full conformity with the Act, he shall include—

(i) A statement that he will cause such defect or noncompliance to be remedied without charge, and whether such remedy will be by repair, replacement, or (except in the case of replacement equipment) refund, less depreciation, of the purchase price.

(ii) The earliest date on which the defect or noncompliance will be remedied without charge. In the case of remedy by repair, this date shall be the earliest date on which the manufacturer reasonably expects that dealers or other service facilities will receive necessary parts and instructions. The manufacturer shall specify the last date, if any, on which he will remedy tires without charge.

(iii) In the case of remedy by repair through the manufacturer's dealers or other service facilities:

§577.5

49 CFR Ch. V (10–1–10 Edition)

(A) A general description of the work involved in repairing the defect or non-compliance; and

(B) The manufacturer's estimate of the time reasonably necessary to perform the labor required to correct the defect or noncompliance.

(iv) In the case of remedy by repair through service facilities other than those of the manufacturer or its dealers:

(A) The name and part number of each part must be added, replaced, or modified;

(B) A description of any modifications that must be made to existing parts, which shall also be identified by name and part number;

(C) Information as to where needed parts will be available;

(D) A detailed description (including appropriate illustrations) of each step required to correct the defect or non-compliance;

(E) The manufacturer's estimate of the time reasonably necessary to perform the labor required to correct the defect or noncompliance; and

(F) The manufacturer's recommendations of service facilities where the owner should have the repairs performed.

(v) In the case of remedy by replacement, a description of the motor vehicle or item of replacement equipment that the manufacturer will provide as a replacement for the defective or non-complying vehicle or equipment.

(vi) In the case of remedy by refund of purchase price, the method or basis for the manufacturer's assessment of depreciation.

(vii) A statement informing the owner that he or she may submit a complaint to the Administrator, National Highway Traffic Safety Administration, 1200 New Jersey Ave., SE., Washington, DC 20590; or call the toll-free Vehicle Safety Hotline at 1-888-327-4236 (TTY: 1-800-424-9153); or go to <http://www.safercar.gov>, if the owner believes that:

(A) The manufacturer, distributor, or dealer has failed or is unable to remedy the defect or noncompliance without charge.

(B) The manufacturer has failed or is unable to remedy the defect or non-compliance without charge—

(1) (In the case of motor vehicles or items of replacement equipment, other than tires) within a reasonable time, which is not longer than 60 days in the case of repair after the owner's first tender to obtain repair following the earliest repair date specified in the notification, unless the period is extended by Administrator.

(2) (In the case of tires) after the date specified in the notification on which replacement tires will be available.

(2) When the manufacturer is not required to remedy the defect or non-compliance without charge and he will not voluntarily so remedy, the statement shall include—

(i) A statement that the manufacturer is not required by the Act to remedy without charge.

(ii) A statement of the extent to which the manufacturer will voluntarily remedy, including the method of remedy and any limitations and conditions imposed by the manufacturer on such remedy.

(iii) The manufacturer's opinion whether the defect or noncompliance can be remedied by repair. If the manufacturer believes that repair is possible, the statement shall include the information specified in paragraph (g)(1)(iv) of this section, except that;

(A) The statement required by paragraph (g)(1)(iv)(A) of this section shall also indicate the suggested list price of each part.

(B) The statement required by paragraph (g)(1)(iv)(C) of this section shall also indicate the manufacturer's estimate of the date on which the parts will be generally available.

(h) Any lessor who receives a notification of a determination of a safety-related defect or noncompliance pertaining to any leased motor vehicle shall send a copy of such notice to the lessee as prescribed by §577.7(a)(2)(iv). This requirement applies to both initial and follow-up notifications, but

does not apply where the manufacturer has notified a lessor's lessees directly.

(Authority: Secs. 108, 112, and 119, Pub. L. 89-563; 80 Stat. 718; secs. 102, 103, and 104, Pub. L. 93-492, 88 Stat. 1470 (15 U.S.C. 1397, 1401, 1408, and 1411-1420); delegation of authority at 49 CFR 1.50)

[41 FR 56816, Dec. 30, 1976, as amended at 46 FR 6971, Jan. 22, 1981; 46 FR 28657, May 28, 1981; 60 FR 17270, Apr. 5, 1995; 61 FR 279, Jan. 4, 1996; 68 FR 18142, Apr. 15, 2003; 70 FR 35557, June 21, 2005; 72 FR 32016, June 11, 2007]

§ 577.6 Notification pursuant to Administrator's decision.

(a) *Agency-ordered notification.* When a manufacturer is ordered pursuant to 49 U.S.C. 30118(b) to provide notification of a defect or noncompliance, he shall provide such notification in accordance with §§ 577.5 and 577.7, except that the statement required by paragraph (c) of § 577.5 shall indicate that the decision has been made by the Administrator of the National Highway Traffic Safety Administration.

(b) *Provisional notification.* When a manufacturer does not provide notification as required by paragraph (a) of this section, and an action concerning the Administrator's order to provide such notification has been filed in a United States District Court, the manufacturer shall, upon the Administrator's further order, provide in accordance with paragraph (b) of § 577.7 a provisional notification containing the information specified in this paragraph, in the order and, where specified, the form of paragraphs (b)(1) through (b)(12) of this section.

(1) An opening statement: "This notice is sent to you in accordance with the requirements of the National Traffic and Motor Vehicle Safety Act."

(2) Whichever of the following statements is appropriate:

(i) "The Administrator of the National Highway Traffic Safety Administration has decided that a defect which relates to motor vehicle safety exists in (identified motor vehicles, in the case of notification sent by a manufacturer of motor vehicles; identified replacement equipment, in the case of notification sent by a manufacturer of replacement equipment);" or

(ii) "The Administrator of the National Highway Traffic Safety Admin-

istration has decided that (identified motor vehicles in the case of notification sent by a motor vehicle manufacturer; identified replacement equipment, in the case of notification sent by a manufacturer of replacement equipment) fail to conform to federal Motor Vehicle Safety Standard No. (number and title of standard)."

(3) When the Administrator decides that the defect or noncompliance may not exist in each such vehicle or item of replacement equipment, the manufacturer may include an additional statement to that effect.

(4) The statement: "(Manufacturer's name or division) is contesting this determination in a proceeding in the Federal courts and has been required to issue this notice pending the outcome of the court proceeding."

(5) A clear description of the Administrator's stated basis for his decision, as provided in his order, including a brief summary of the evidence and reasoning that the Administrator relied upon in making his decision.

(6) A clear description of the Administrator's stated evaluation as provided in his order of the risk to motor vehicle safety reasonably related to the defect or noncompliance.

(7) Any measures that the Administrator has stated in his order should be taken by the owner to avoid an unreasonable hazard resulting from the defect or noncompliance.

(8) A brief summary of the evidence and reasoning upon which the manufacturer relies in contesting the Administrator's determination.

(9) A statement regarding the availability of remedy and reimbursement in accordance with paragraph (b)(9)(i) or (9)(ii) of this section, whichever is appropriate.

(i) When the purchase date of the vehicle or item of equipment is such that the manufacturer is required by the Act to remedy without charge or to reimburse the owner for reasonable and necessary repair expenses, he shall include—

(A) A statement that the remedy will be provided without charge to the owner if the Court upholds the Administrator's decision;

(B) A statement of the method of remedy. If the manufacturer has not

§577.6

49 CFR Ch. V (10-1-10 Edition)

yet determined the method of remedy, he shall indicate that he will select either repair, replacement with an equivalent vehicle or item of replacement equipment, or (except in the case of replacement equipment) refund, less depreciation, of the purchase price; and

(C) A statement that, if the Court upholds the Administrator's decision, he will reimburse the owner for any reasonable and necessary expenses that the owner incurs (not in excess of any amount specified by the Administrator) in repairing the defect or non-compliance following a date, specified by the manufacturer, which shall not be later than the date of the Administrator's order to issue this notification.

(ii) When the manufacturer is not required either to remedy without charge or to reimburse, he shall include—

(A) A statement that he is not required to remedy or reimburse, or

(B) A statement of the extent to which he will voluntarily remedy or reimburse, including the method of remedy, if then known, and any limitations and conditions on such remedy or reimbursement.

(10) A statement indicating whether, in the manufacturer's opinion, the defect or noncompliance can be remedied by repair. When the manufacturer believes that such remedy is feasible, the statement shall include:

(i) A general description of the work and the manufacturer's estimate of the costs involved in repairing the defect or noncompliance;

(ii) Information on where needed parts and instructions for repairing the defect or noncompliance will be available, including the manufacturer's estimate of the day on which they will be generally available;

(iii) The manufacturer's estimate of the time reasonably necessary to perform the labor required to correct the defect or noncompliance; and

(iv) The manufacturer's recommendations of service facilities where the owner could have the repairs performed, including (in the case of a manufacturer required to reimburse if the Administrator's decision is upheld in the court proceeding) at least one service facility for whose charges the owner will be fully reimbursed if the Administrator's decision is upheld.

(11) A statement that further notice will be mailed by the manufacturer to the owner if the Administrator's decision is upheld in the court proceeding.

(12) An address of the manufacturer where the owner may write to obtain additional information regarding the notification and remedy.

(c) *Post-litigation notification.* When a manufacturer does not provide notification as required in paragraph (a) of this section and the Administrator prevails in an action commenced with respect to such notification, the manufacturer shall, upon the Administrator's further order, provide notification in accordance with paragraph (b) of §577.7 containing the information specified in paragraph (a) of this section, except that—

(1) The statement required by paragraph (c) of §577.5 shall indicate that the decision has been made by the Administrator and that his decision has been upheld in a proceeding in the Federal courts; and

(2) When a provisional notification was issued regarding the defect or non-compliance and the manufacturer is required under the Act to reimburse—

(i) The manufacturer shall state that he will reimburse the owner for any reasonable and necessary expenses that the owner incurred (not in excess of any amount specified by the Administrator) for repair of the defect or non-compliance of the vehicle or item of equipment on or after the date on which provisional notification was ordered to be issued and on or before a date not sooner than the date on which this notification is received by the owner. The manufacturer shall determine and specify both dates.

(ii) The statement required by paragraph (g)(1)(vii) of §577.5 shall also inform the owner that he may submit a complaint to the Administrator if the owner believes that the manufacturer has failed to reimburse adequately.

(3) If the manufacturer is not required under the Act to reimburse, he shall include—

(i) A statement that he is not required to reimburse, or

(ii) When he will voluntarily reimburse, a statement of the extent to

which he will do so, including any limitations and conditions on such reimbursement.

[41 FR 56816, Dec. 30, 1976, as amended at 60 FR 17271, Apr. 5, 1995]

§577.7 Time and manner of notification.

(a) The notification required by §577.5 shall—

(1) Be furnished within a reasonable time after the manufacturer first decides that either a defect that relates to motor vehicle safety or a noncompliance exists. The Administrator may order a manufacturer to send the notification to owners on a specific date where the Administrator finds, after consideration of available information and the views of the manufacturer, that such notification is in the public interest. The factors that the Administrator may consider include, but are not limited to, the severity of the safety risk; the likelihood of occurrence of the defect or noncompliance; whether there is something that an owner can do to reduce either the likelihood of occurrence of the defect or noncompliance or the severity of the consequences; whether there will be a delay in the availability of the remedy from the manufacturer; and the anticipated length of any such delay.

(2) Be accomplished—

(i) In the case of a notification required to be sent by a motor vehicle manufacturer, by first class mail to each person who is registered under State law as the owner of the vehicle and whose name and address are reasonably ascertainable by the manufacturer through State records or other sources available to him. If the owner cannot be reasonably ascertained, the manufacturer shall notify the most recent purchaser known to the manufacturer. The manufacturer shall also provide notification to each lessee of a leased motor vehicle that is covered by an agreement between the manufacturer and a lessor under which the manufacturer is to notify lessees directly of safety-related defects and noncompliances.

(ii) In the case of a notification required to be sent by a replacement equipment manufacturer—

(A) By first class mail to the most recent purchaser known to the manufacturer, and

(B) (Except in the case of a tire) if decided by the Administrator to be required for motor vehicle safety, by public notice in such manner as the Administrator may require after consultation with the manufacturer.

(iii) In the case of a manufacturer required to provide notification concerning any defective or noncomplying tire, by first class or certified mail.

(iv) In the case of a notification to be sent by a lessor to a lessee of a leased motor vehicle, by first-class mail to the most recent lessee known to the lessor. Such notification shall be mailed within ten days of the lessor's receipt of the notification from the vehicle manufacturer.

(b) The notification required by any paragraph of §577.6 shall be provided:

(1) Within 60 days after the manufacturer's receipt of the Administrator's order to provide the notification, except that the notification shall be furnished within a shorter or longer period if the Administrator incorporates in his order a finding that such period is in the public interest; and

(2) In the manner and to the recipient specified in paragraph (a) of this section.

(c) The notification required by §577.13 shall—

(1) Be furnished within a reasonable time after the manufacturer decides that a defect that relates to motor vehicle safety or a noncompliance exists. In the case of defects or noncompliances that present an immediate and substantial threat to motor vehicle safety, the manufacturer shall transmit this notice to dealers and distributors within three business days of its transmittal of the Defect and Noncompliance Information Report under 49 CFR 573.6 to NHTSA, except that when the manufacturer transmits the notice by other than electronic means, the manufacturer shall transmit this notice to dealers and distributors within five business days of its transmittal of the Defect and Noncompliance Information Report to NHTSA. In all other cases, the notification shall be provided in accordance with the schedule submitted to the agency pursuant to

§ 577.8

§ 573.6(c)(8)(ii), unless that schedule is modified by the Administrator. The Administrator may direct a manufacturer to send the notification to dealers on a specific date if the Administrator finds, after consideration of available information and the views of the manufacturer, that such notification is in the public interest. The factors that the Administrator may consider include, but are not limited to, the severity of the safety risk; the likelihood of occurrence of the defect or noncompliance; the time frame in which the defect or noncompliance may manifest itself; availability of an interim remedial action by the owner; whether a dealer inspection would identify vehicles or items of equipment that contain the defect or noncompliance; and the time frame in which the manufacturer plans to provide the notification and the remedy to its dealers.

(2) Be accomplished—

(i) In the case of a notification required to be sent by a motor vehicle manufacturer, by certified mail, verifiable electronic means such as receipts or logs from electronic mail or satellite distribution system, or other more expeditious and verifiable means to all dealers and distributors of the vehicles that contain the defect or noncompliance.

(ii) In the case of a notification required to be sent by a manufacturer of replacement equipment or tires, by certified mail, verifiable electronic means such as receipts or logs from electronic mail or satellite distribution system, or other more expeditious and verifiable means to all dealers and distributors of the product that are known to the manufacturer.

(iii) In those cases where a manufacturer of motor vehicles or items of motor vehicle equipment provided the recalled product(s) to a group of dealers or distributors through a central office, notification to that central office will be deemed to be notice to all dealers and distributors within that group.

(iv) In those cases in which a manufacturer of motor vehicles or items of motor vehicle equipment has provided the recalled product to independent dealers through independent distribu-

49 CFR Ch. V (10–1–10 Edition)

tors, the manufacturer may satisfy its notification responsibilities by providing the information required under this section to its distributors. In such cases, the manufacturer must also instruct those distributors to transmit a copy of the manufacturer's notification to known distributors and retail outlets along the distribution chain within five working days from its receipt.

(d) Notwithstanding paragraph (c)(1) of this section, where the recall is being conducted pursuant to an order issued by the Administrator under 49 U.S.C. 30118(b), notification required by § 577.13 shall be given on or before the date prescribed in the Administrator's order.

[41 FR 56816, Dec. 30, 1976, as amended at 60 FR 17271, Apr. 5, 1995; 69 FR 34959, June 23, 2004; 70 FR 38814, July 6, 2005]

§ 577.8 Disclaimers.

(a) A notification sent pursuant to §§ 577.5, 577.6, 577.9 or 577.10 regarding a defect which relates to motor vehicle safety shall not, except as specifically provided in this part, contain any statement or implication that there is no defect, that the defect does not relate to motor vehicle safety, or that the defect is not present in the owner's or lessee's vehicle or item of replacement equipment. This section also applies to any notification sent to a lessor or directly to a lessee by a manufacturer.

(b) A notification sent pursuant to §§ 577.5, 577.6, 577.9 or 577.10 regarding a noncompliance with an applicable motor vehicle safety standard shall not, except as specifically provided in this part, contain any statement or implication that there is not a noncompliance, or that the noncompliance is not present in the owner's or lessee's vehicle or item of replacement equipment. This section also applies to any notification sent to a lessor or directly to a lessee by a manufacturer.

[60 FR 17272, Apr. 5, 1995]

§ 577.9 Conformity to statutory requirements.

A notification that does not conform to the requirements of this part is a violation of the Act.

§ 577.10 Follow-up notification.

(a) If, based on quarterly reports submitted pursuant to § 573.7 of this part or other available information, the Administrator decides that a notification of a safety-related defect of a non-compliance with a Federal motor vehicle safety standard sent by a manufacturer has not resulted in an adequate number of vehicles or items of equipment being returned for remedy, the Administrator may direct the manufacturer to send a follow-up notification in accordance with this section. The scope, timing, form, and content of such follow-up notification will be established by the Administrator, in consultation with the manufacturer, to maximize the number of owners, purchasers, and lessees who will present their vehicles or items of equipment for remedy.

(b) The Administrator may consider the following factors in deciding whether or not to require a manufacturer to undertake a follow-up notification campaign:

(1) The percentage of covered vehicles or items of equipment that have been presented for the remedy;

(2) The amount of time that has elapsed since the prior notification(s);

(3) The likelihood that a follow-up notification will increase the number of vehicles or items of equipment receiving the remedy;

(4) The seriousness of the safety risk from the defect or noncompliance;

(5) Whether the prior notification(s) undertaken by the manufacturer complied with the requirements of the statute and regulations; and

(6) Such other factors as are consistent with the purpose of the statute.

(c) A manufacturer shall be required to provide a follow-up notification under this section only with respect to vehicles or items of equipment that have not been returned for remedy pursuant to the prior notification(s).

(d) Except where the Administrator determines otherwise, the follow-up notification shall be sent to the same categories of recipients that received the prior notification(s).

(e) A follow-up notification must include:

(1) A statement that identifies it as a follow-up to an earlier communication;

(2) A statement urging the recipient to present the vehicle or item of equipment for remedy; and

(3) Except as determined by the Administrator, the information required to be included in the initial notification.

(f) The manufacturer shall mark the outside of each envelope in which it sends a follow-up notification in a manner which meets the requirements of § 577.5(a) of this part.

(g) Notwithstanding any other provision of this part, the Administrator may authorize the use of other media besides first-class mail for a follow-up notification.

[60 FR 17272, Apr. 5, 1995, as amended at 68 FR 18142, Apr. 15, 2003]

§ 577.11 Reimbursement notification.

(a) Except as otherwise provided in paragraph (e) of this section, when a manufacturer of motor vehicles or replacement equipment is required to provide notice in accordance with §§ 577.5 or 577.6, in addition to complying with other sections of this part, the manufacturer shall notify owners that they may be eligible to receive reimbursement for the cost of obtaining a pre-notification remedy of a problem associated with a defect or noncompliance consistent with the manufacturer's reimbursement plan submitted to NHTSA pursuant to §§ 573.6(c)(8)(i) and 573.13 of this chapter.

(b) The manufacturer's notification shall include a statement, following the items required by § 577.5 or § 577.6, that

(1) Refers to the possible eligibility for reimbursement for the cost of repair or replacement; and

(2) Describes how a consumer may obtain information about reimbursement from the manufacturer;

(c) The information referred to in § 577.11(b)(2) of this part shall be provided in one of the following ways:

(1) In an enclosure to the notification under § 577.5 or § 577.6 that provides the information described in § 577.11(d), consistent with the manufacturer's reimbursement plan; or

(2) Through a toll-free telephone number (with TTY capability) identified in the notification that provides the information described in § 577.11(d),

§ 577.12

49 CFR Ch. V (10–1–10 Edition)

consistent with the manufacturer's reimbursement plan.

(3) For notifications of defects or noncompliances in item of motor vehicle equipment that are in a form other than a letter to a specific owner or purchaser, if the manufacturer does not otherwise maintain a toll-free telephone number for the use of consumers, the manufacturer may refer claimants to a non-toll-free telephone number (with TTY capability) if it also specifies a mailing address at which owners can obtain the relevant information regarding the manufacturer's reimbursement plan.

(d) The information to be provided under paragraph (c) of this section must:

(1) Identify the vehicle and/or equipment that is the subject of the recall and the underlying problem;

(2) State that the manufacturer has a program for reimbursing pre-notification remedies and identify the type of remedy eligible for reimbursement;

(3) Identify any limits on the time period in which the repair or replacement of the recalled vehicle or equipment must have occurred;

(4) Identify any restrictions on eligibility for reimbursement that the manufacturer is imposing (as limited by § 573.13 (d) of this chapter);

(5) Specify all necessary documentation that must be submitted to obtain reimbursement;

(6) Explain how to submit a claim for reimbursement of a pre-notification remedy; and

(7) Identify the office and address of the manufacturer where a claim can be submitted by mail and any authorized dealers or facilities where a claimant may submit a claim for reimbursement.

(e) The manufacturer is not required to provide notification regarding reimbursement under this section if NHTSA finds, based upon a written request by a manufacturer accompanied by supporting information, views, and arguments, that all covered vehicles are under warranty or that no person would be eligible for reimbursement under § 573.13 of this chapter.

[67 FR 64065, Oct. 17, 2002]

§ 577.12 Notification pursuant to an accelerated remedy program.

(a) When the Administrator requires a manufacturer to accelerate its remedy program under § 573.14 of this chapter, or when a manufacturer agrees with a request from the Administrator that it accelerate its remedy program in advance of being required to do so, in addition to complying with other sections of this part, the manufacturer shall provide notification in accordance with this section.

(b) Except as provided elsewhere in this section or when the Administrator determines otherwise, the notification under this section shall be sent to the same recipients as provided by § 577.7. If no notification has been provided to owners pursuant to this part, the provisions required by this section may be combined with the notification under §§ 577.5 or 577.6. A manufacturer need only provide a notification under this section to owners of vehicles or items of equipment for which the defect or noncompliance has not been remedied.

(c) The manufacturer's notification shall include the following:

(1) If there was a prior notification, a statement that identifies that notification and states that this notification supplements it;

(2) When the accelerated remedy program has been required by the Administrator, a statement that the National Highway Traffic Safety Administration has required the manufacturer to accelerate its remedy program;

(3) A statement of how the program has been accelerated (*e.g.*, by expanding the sources of replacement parts and/or expanding the number of authorized repair facilities);

(4) Where applicable, a statement that the owner may elect to obtain the recall remedy using designated service facilities other than those that are owned or franchised by the manufacturer or are the manufacturer's authorized dealers, and an explanation of how the owner may arrange for service at those other facilities;

(5) Where applicable, a statement that the owner may elect to obtain the recall remedy using specified replacement parts or equipment from sources other than the manufacturer;

(6) Where applicable, a statement indicating whether the owner will be required to pay an alternative facility and/or parts supplier, subject to reimbursement by the manufacturer; and

(7) If an owner will be required to pay an alternative facility and/or parts supplier, a statement that the owner will be eligible to have those expenditures reimbursed by the manufacturer, and a description of how a consumer may obtain information about reimbursement from the manufacturer consistent with § 577.11(b)(2), (c) and (d).

[67 FR 72393, Dec. 5, 2002]

§ 577.13 Notification to dealers and distributors.

(a) The notification to dealers and distributors of a safety-related defect or a noncompliance with a Federal motor vehicle safety standard shall contain a clear statement that identifies the notification as being a safety recall notice, an identification of the motor vehicles or items of motor vehicle equipment covered by the recall, a description of the defect or noncompliance, and a brief evaluation of the risk to motor vehicle safety related to the defect or noncompliance. The notification shall also include a complete description of the recall remedy, and the estimated date on which the remedy will be available. Information required by this paragraph that is not available at the time of the original notification shall be provided as it becomes available.

(b) The notification shall also include an advisory stating that it is a violation of Federal law for a dealer to deliver a new motor vehicle or any new or used item of motor vehicle equipment (including a tire) covered by the notification under a sale or lease until the defect or noncompliance is remedied.

(c) The manufacturer shall, upon request of the Administrator, demonstrate that it sent the required notification to each of its known dealers and distributors and the date of such notification.

[69 FR 34960, June 23, 2004, as amended at 70 FR 38815, July 6, 2005]

PART 578—CIVIL AND CRIMINAL PENALTIES

Sec.

578.1 Scope.

578.2 Purpose.

578.3 Applicability.

578.4 Definitions.

578.5 Inflationary adjustment of civil penalties.

578.6 Civil penalties for violations of specified provisions of Title 49 of the United States Code.

578.7 Criminal safe harbor provision.

AUTHORITY: Pub. L. No. 101-410, Pub. L. No. 104-134, 49 U.S.C. 30165, 30170, 30505, 32304A, 32308, 32309, 32507, 32709, 32710, 32912, and 33115 as amended; delegation of authority at 49 CFR 1.50.

SOURCE: 62 FR 5169, Feb. 4, 1997, unless otherwise noted.

§ 578.1 Scope.

This part specifies the civil penalties for violations of statutes administered by the National Highway Traffic Safety Administration, as adjusted for inflation. This part also sets forth the requirements regarding the reasonable time and the manner of correction for a person seeking safe harbor protection from criminal liability under 49 U.S.C. 30170(a).

[65 FR 81418, Dec. 26, 2000]

§ 578.2 Purpose.

One purpose of this part is to preserve the remedial impact of civil penalties and to foster compliance with the law by specifying the civil penalties for statutory violations, as adjusted for inflation. The other purpose of this part is to set forth the requirements regarding the reasonable time and the manner of correction for a person seeking safe harbor protection from criminal liability under 49 U.S.C. 30170(a).

[65 FR 81418, Dec. 26, 2000]

§ 578.3 Applicability.

This part applies to civil penalties for violations of Chapters 301, 305, 323, 325, 327, 329, and 331 of Title 49 of the

§ 578.4

United States Code. This part also applies to the criminal penalty safe harbor provision of section 30170 of Title 49 of the United States Code.

[65 FR 81419, Dec. 26, 2000]

§ 578.4 Definitions.

All terms used in this part that are defined in sections 30102, 30501, 32101, 32702, 32901, and 33101 of Title 49 of the United States Code are used as defined in the appropriate statute.

Administrator means the Administrator of the National Highway Traffic Safety Administration.

Civil penalty means any non-criminal penalty, fine, or other sanction that:

(1) Is for a specific monetary amount as provided by Federal law, or has a maximum amount provided for by Federal law; and

(2) Is assessed, compromised, collected, or enforced by NHTSA pursuant to Federal law.

NHTSA means the National Highway Traffic Safety Administration.

[62 FR 5169, Feb. 4, 1997, as amended at 65 FR 81419, Dec. 26, 2000]

§ 578.5 Inflationary adjustment of civil penalties.

The civil penalties set forth in this part continue in effect until adjusted by the Administrator. At least once every four years, the Administrator shall review the amount of these civil penalties and will, if appropriate, adjust them by rule.

§ 578.6 Civil penalties for violations of specified provisions of Title 49 of the United States Code.

(a) *Motor vehicle safety*—(1) *In general.* A person who violates any of sections 30112, 30115, 30117 through 30122, 30123(a), 30125(c), 30127, or 30141 through 30147 of Title 49 of the United States Code or a regulation prescribed under any of those sections is liable to the United States Government for a civil penalty of not more than \$6,000 for each violation. A separate violation occurs for each motor vehicle or item of motor vehicle equipment and for each failure or refusal to allow or perform an act required by any of those sections. The maximum civil penalty

49 CFR Ch. V (10–1–10 Edition)

under this paragraph for a related series of violations is \$16,375,000.

(2) *School buses.* Notwithstanding paragraph (a)(1) of this section, a person who:

(i) Violates section 30112(a)(1) of Title 49 United States Code by the manufacture, sale, offer for sale, introduction or delivery for introduction into interstate commerce, or importation of a school bus or school bus equipment (as those terms are defined in 49 U.S.C. § 30125(a)); or

(ii) Violates section 30112(a)(2) of Title 49 United States Code, shall be subject to a civil penalty of not more than \$11,000 for each violation. A separate violation occurs for each motor vehicle or item of motor vehicle equipment and for each failure or refusal to allow or perform an act required by this section. The maximum penalty under this paragraph for a related series of violations is \$16,650,000.

(3) *Section 30166.* A person who violates section 30166 of Title 49 of the United States Code or a regulation prescribed under that section is liable to the United States Government for a civil penalty for failing or refusing to allow or perform an act required under that section or regulation. The maximum penalty under this paragraph is \$6,000 per violation per day. The maximum penalty under this paragraph for a related series of daily violations is \$16,375,000.

(b) *National Automobile Title Information System.* An individual or entity violating 49 U.S.C. Chapter 305 is liable to the United States Government for a civil penalty of not more than \$1,100 for each violation.

(c) *Bumper standards.* (1) A person that violates 49 U.S.C. § 32506(a) is liable to the United States Government for a civil penalty of not more than \$1,100 for each violation. A separate violation occurs for each passenger motor vehicle or item of passenger motor vehicle equipment involved in a violation of 49 U.S.C. 32506(a)(1) or (4)—

(i) That does not comply with a standard prescribed under 49 U.S.C. 32502, or

(ii) For which a certificate is not provided, or for which a false or misleading certificate is provided, under 49 U.S.C. 32504.

(2) The maximum civil penalty under this paragraph (c) for a related series of violations is \$1,175,000.

(d) *Consumer information*—(1) *Crashworthiness and damage susceptibility*. A person that violates 49 U.S.C. 32308(a), regarding crashworthiness and damage susceptibility, is liable to the United States Government for a civil penalty of not more than \$1,100 for each violation. Each failure to provide information or comply with a regulation in violation of 49 U.S.C. 32308(a) is a separate violation. The maximum penalty under this paragraph for a related series of violations is \$575,000.

(2) *Consumer tire information*. Any person who fails to comply with the national tire fuel efficiency program under 49 U.S.C. 32304A is liable to the United States Government for a civil penalty of not more than \$50,000 for each violation.

(e) *Country of origin content labeling*. A manufacturer of a passenger motor vehicle distributed in commerce for sale in the United States that willfully fails to attach the label required under 49 U.S.C. 32304 to a new passenger motor vehicle that the manufacturer manufactures or imports, or a dealer that fails to maintain that label as required under 49 U.S.C. 32304, is liable to the United States Government for a civil penalty of not more than \$1,100 for each violation. Each failure to attach or maintain that label for each vehicle is a separate violation.

(f) *Odometer tampering and disclosure*. (1) A person that violates 49 U.S.C. Chapter 327 or a regulation prescribed or order issued thereunder is liable to the United States Government for a civil penalty of not more than \$3,200 for each violation. A separate violation occurs for each motor vehicle or device involved in the violation. The maximum civil penalty under this paragraph for a related series of violations is \$140,000.

(2) A person that violates 49 U.S.C. Chapter 327 or a regulation prescribed or order issued thereunder, with intent to defraud, is liable for three times the actual damages or \$2,000, whichever is greater.

(g) *Vehicle theft protection*. (1) A person that violates 49 U.S.C. 33114(a)(1)–(4) is liable to the United States Gov-

ernment for a civil penalty of not more than \$1,100 for each violation. The failure of more than one part of a single motor vehicle to conform to an applicable standard under 49 U.S.C. 33102 or 33103 is only a single violation. The maximum penalty under this paragraph for a related series of violations is \$350,000.

(2) A person that violates 49 U.S.C. 33114(a)(5) is liable to the United States Government for a civil penalty of not more than \$140,000 a day for each violation.

(h) *Automobile fuel economy*. (1) A person that violates 49 U.S.C. 32911(a) is liable to the United States Government for a civil penalty of not more than \$16,000 for each violation. A separate violation occurs for each day the violation continues.

(2) Except as provided in 49 U.S.C. 32912(c), a manufacturer that violates a standard prescribed for a model year under 49 U.S.C. 32902 is liable to the United States Government for a civil penalty of \$5.50 multiplied by each .1 of a mile a gallon by which the applicable average fuel economy standard under that section exceeds the average fuel economy—

(i) Calculated under 49 U.S.C. 32904(a)(1)(A) or (B) for automobiles to which the standard applies manufactured by the manufacturer during the model year;

(ii) Multiplied by the number of those automobiles; and

(iii) Reduced by the credits available to the manufacturer under 49 U.S.C. 32903 for the model year.

[62 FR 5169, Feb. 4, 1997, as amended at 64 FR 37878, July 14, 1999; 65 FR 68110, Nov. 14, 2000; 66 FR 41151, Aug. 7, 2001; 69 FR 57866, Sept. 28, 2004; 70 FR 53311, Sept. 8, 2005; 71 FR 28281, May 16, 2006; 73 FR 9956, Feb. 25, 2008; 75 FR 5248, Feb. 2, 2010]

§578.7 Criminal safe harbor provision.

(a) *Scope*. This section sets forth the requirements regarding the reasonable time and the manner of correction for a person seeking safe harbor protection from criminal liability under 49 U.S.C. 30170(a)(2), which provides that a person described in 49 U.S.C. 30170(a)(1) is not subject to criminal penalties thereunder if:

(1) At the time of the violation, such person does not know that the violation would result in an accident causing death or serious bodily injury; and

(2) The person corrects any improper reports or failure to report, with respect to reporting requirements of 49 U.S.C. 30166, within a reasonable time.

(b) *Reasonable time.* A correction is considered to have been performed within a reasonable time if the person seeking protection from criminal liability makes the correction to any improper (i.e., incorrect, incomplete, or misleading) report not more than thirty (30) calendar days after the date of the report to the agency and corrects any failure to report not more than thirty (30) calendar days after the report was due to be sent to or received by the agency, as the case may be, pursuant to 49 U.S.C. 30166, including a regulation, requirement, request or order issued thereunder. In order to meet these reasonable time requirements, all submissions required by this section must be received by NHTSA within the time period specified in this paragraph, and not merely mailed or otherwise sent within that time period.

(c) *Sufficient manner of correction.* Each person seeking safe harbor protection from criminal penalties under 49 U.S.C. 30170(a)(2) must comply with the following with respect to each improper report and failure to report for which safe harbor protection is sought:

(1) Sign and submit to NHTSA a dated document identifying:

(i) Each previous improper report (e.g., informational statement and document submission), and each failure to report as required under 49 U.S.C. 30166, including a regulation, requirement, request or order issued thereunder, for which protection is sought, and

(ii) The specific predicate under which the improper or omitted report should have been provided (e.g., the report was required by a specified regulation, NHTSA Information Request, or NHTSA Special Order).

(2) Submit the complete and correct information that was required to be submitted but was improperly submitted or was not previously submitted, including relevant documents that were not previously submitted, or, if the person cannot do so, provide a

detailed description of that information and/or the content of those documents and the reason why the individual cannot provide them to NHTSA (e.g., the information or documents are not in the individual's possession or control).

(3) For a corporation, the submission must be signed by an authorized person (ordinarily, the individual officer or employee who submitted the improper report or who should have provided the report that the corporation failed to submit on behalf of the company, or someone in the company with authority to make such a submission).

(4) Submissions must be made by a means which permits the sender to verify promptly that the report was in fact received by NHTSA and the day it was received by NHTSA.

(5) Submit the report to Chief Counsel (NCC–10), National Highway Traffic Safety Administration, Room 5219, 400 Seventh Street, SW., Washington, DC 20590.

[65 FR 81419, Dec. 26, 2000, as amended at 66 FR 38384, July 24, 2001]

PART 579—REPORTING OF INFORMATION AND COMMUNICATIONS ABOUT POTENTIAL DEFECTS

Subpart A—General

Sec.

579.1 Scope.

579.2 Purpose.

579.3 Application.

579.4 Terminology.

579.5 Notices, bulletins, customer satisfaction campaigns, consumer advisories, and other communications.

579.6 Address for submitting reports and other information.

579.7–579.10 [Reserved]

Subpart B—Reporting of Safety Recalls and Other Safety Campaigns in Foreign Countries

579.11 Reporting responsibilities.

579.12 Contents of reports.

579.13–579.20 [Reserved]

Subpart C—Reporting of Early Warning Information

579.21 Reporting requirements for manufacturers of 5,000 or more light vehicles annually.

- 579.22 Reporting requirements for manufacturers of 100 or more buses, manufacturers of 500 or more emergency vehicles and manufacturers of 5,000 or more medium-heavy vehicles (other than buses and emergency vehicles) annually.
- 579.23 Reporting requirements for manufacturers of 5,000 or more motorcycles annually.
- 579.24 Reporting requirements for manufacturers of 5,000 or more trailers annually.
- 579.25 Reporting requirements for manufacturers of child restraint systems.
- 579.26 Reporting requirements for manufacturers of tires.
- 579.27 Reporting requirements for manufacturers of fewer than 100 buses annually, for manufacturers of fewer than 500 emergency vehicles annually, for manufacturers of fewer than 5,000 light vehicles, medium-heavy vehicles (other than buses and emergency vehicles), motorcycles or trailers annually, for manufacturers of original equipment, and for manufacturers of replacement equipment other than child restraint systems and tires.
- 579.28 Due date of reports and other miscellaneous provisions.
- 579.29 Manner of reporting.

AUTHORITY: 49 U.S.C. 30102-103, 30112, 30117-121, 30166-167; delegation of authority at 49 CFR 1.50 and 49 CFR 501.8.

SOURCE: 67 FR 45873, July 10, 2002, unless otherwise noted.

Subpart A—General

§ 579.1 Scope.

This part sets forth requirements for reporting information and submitting documents that may help identify defects related to motor vehicle safety and noncompliances with Federal motor vehicle safety standards, including reports of foreign safety recalls and other safety-related campaigns conducted outside the United States under 49 U.S.C. 30166(l), early warning information under 49 U.S.C. 30166(m), and copies of communications about defects and noncompliances under 49 U.S.C. 30166(f).

§ 579.2 Purpose.

The purpose of this part is to enhance motor vehicle safety by specifying information and documents that manufacturers of motor vehicles and motor vehicle equipment must provide to NHTSA with respect to possible safety-related defects and noncompli-

ances in their products, including the reporting of safety recalls and other safety campaigns that the manufacturer conducts outside the United States.

[67 FR 63310, Oct. 11, 2002]

§ 579.3 Application.

(a) This part applies to all manufacturers of motor vehicles and motor vehicle equipment with respect to all motor vehicles and motor vehicle equipment that have been offered for sale, sold, or leased in the United States by the manufacturer, including any parent corporation, any subsidiary or affiliate of the manufacturer, or any subsidiary or affiliate of any parent corporation, and with respect to all motor vehicles and motor vehicle equipment that have been offered for sale, sold, or leased in a foreign country by the manufacturer, including any parent corporation, any subsidiary or affiliate of the manufacturer, or any subsidiary or affiliate of any parent corporation, and are identical or substantially similar to any motor vehicles or motor vehicle equipment that have been offered for sale, sold, or leased in the United States.

(b) In the case of any report required under subpart B of this part, compliance by the fabricating manufacturer, the importer, the brand name owner, or a parent or subsidiary of such fabricator, importer, or brand name owner of the motor vehicle or motor vehicle equipment that is identical or substantially similar to that covered by the foreign recall or other safety campaign, shall be considered compliance by all persons.

(c) In the case of any report required under subpart C of this part, compliance by the fabricating manufacturer, the importer, the brand name owner, or a parent or United States subsidiary of such fabricator, importer, or brand name owner of the motor vehicle or motor vehicle equipment, shall be considered compliance by all persons.

(d) With regard to any information required to be reported under subpart C of this part, an entity covered under paragraph (a) of this section need only review information and systems where information responsive to subpart C of

§ 579.4

49 CFR Ch. V (10–1–10 Edition)

this part is kept in the usual course of business.

[43 FR 38833, Aug. 31, 1978, as amended at 67 FR 63310, Oct. 11, 2002]

§ 579.4 Terminology.

(a) *Statutory terms.* The terms *dealer*, *defect*, *distributor*, *motor vehicle*, *motor vehicle equipment*, and *State* are used as defined in 49 U.S.C. 30102.

(b) *Regulatory terms.* The term *Vehicle Identification Number (VIN)* is used as defined in § 565.3(o) of this chapter. The terms *bus*, *Gross Vehicle Weight Rating (GVWR)*, *motorcycle*, *multipurpose passenger vehicle*, *passenger car*, *trailer*, and *truck* are used as defined in § 571.3(b) of this chapter. The term *Booster seat* is used as defined in S4 of § 571.213 of this chapter. The term *Tire Identification Number (TIN)* is the “tire identification number” described in § 574.5 of this chapter. The term *Limited production tire* is used as defined in § 575.104(c)(2) of this chapter.

(c) *Other terms.* The following terms apply to this part:

Administrator means the Administrator of the National Highway Traffic Safety Administration (NHTSA), or the Administrator’s delegate.

Affiliate means, in the context of an affiliate of or person affiliated with a specified person, a person that directly, or indirectly through one or more intermediaries, controls or is controlled by, or is under common control with, the person specified. The term person usually is a corporation.

Air bag means an air bag or other automatic occupant restraint device (other than a “seat belt” as defined in this subpart) installed in a motor vehicle that restrains an occupant in the event of a vehicle crash without requiring any action on the part of the occupant to obtain the benefit of the restraint. This term includes inflatable restraints (front and side air bags), knee bolsters, and any other automatic restraining device that may be developed that does not include a restraining belt or harness. This term also includes all air bag-related components, such as the inflator assembly, air bag module, control module, crash sensors and all hardware and software associated with the air bag. This term includes all associated switches, control

units, connective elements (such as wiring harnesses, hoses, piping, etc.), and mounting elements (such as brackets, fasteners, etc.).

Base means the detachable bottom portion of a child restraint system that may remain in the vehicle to provide a base for securing the system to a seat in a motor vehicle.

Bead means all the materials in a tire below the sidewalls in the rim contact area, including bead rubber components, the bead bundle and rubber coating if present, the body ply and its turn-up including the rubber coating, rubber, fabric, or metallic reinforcing materials, and the inner-liner rubber under the bead area.

Brand name owner means a person that markets a motor vehicle or motor vehicle equipment under its own trade name whether or not it is the fabricator or importer of the vehicle or equipment.

Buckle and restraint harness means the components of a child restraint system that are intended to restrain a child seated in such a system, including the belt webbing, buckles, buckle release mechanism, belt adjusters, belt positioning devices, and shields.

Child restraint system means any system that meets, or is offered for sale in the United States as meeting, any definition in S4 of § 571.213 of this chapter, or that is offered for sale as a child restraint system in a foreign country.

Claim means a written request or written demand for relief, including money or other compensation, assumption of expenditures, or equitable relief, related to a motor vehicle crash, accident, the failure of a component or system of a vehicle or an item of motor vehicle equipment, or a fire originating in or from a motor vehicle or a substance that leaked from a motor vehicle. Claim includes, but is not limited to, a demand in the absence of a lawsuit, a complaint initiating a lawsuit, an assertion or notice of litigation, a settlement, covenant not to sue or release of liability in the absence of a written demand, and a subrogation request. A claim exists regardless of any denial or refusal to pay it, and regardless of whether it has been settled or resolved in the manufacturer’s favor. The existence of a claim may not be

conditioned on the receipt of anything beyond the document(s) stating a claim. Claim does not include demands related to asbestos exposure, to emissions of volatile organic compounds from vehicle interiors, or to end-of-life disposal of vehicles, parts or components of vehicles, equipment, or parts or components of equipment.

Common green tires means tires that are produced to the same internal specifications but that have, or may have, different external characteristics and may be sold under different tire line names.

Consumer complaint means a communication of any kind made by a consumer (or other person) to or with a manufacturer addressed to the company, an officer thereof or an entity thereof that handles consumer matters, a manufacturer website that receives consumer complaints, a manufacturer electronic mail system that receives such information at the corporate level, or that are otherwise received by a unit within the manufacturer that receives consumer inquiries or complaints, including telephonic complaints, expressing dissatisfaction with a product, or relating the unsatisfactory performance of a product, or any actual or potential defect in a product, or any event that allegedly was caused by any actual or potential defect in a product, but not including a claim of any kind or a notice involving a fatality or injury.

Control (including the terms controlling, controlled by, and under common control with) means the possession, direct or indirect, of the power to direct or cause the direction of the management and policies of a person, whether through the ownership of voting securities, by contract, or otherwise.

Customer satisfaction campaign, consumer advisory, recall, or other activity involving the repair or replacement of motor vehicles or motor vehicle equipment means any communication by a manufacturer to, or made available to, more than one dealer, distributor, lessor, lessee, other manufacturer, or owner, whether in writing or by electronic means, relating to repair, replacement, or modification of a vehicle, component of a vehicle, item of equipment, or a component thereof, the manner in

which a vehicle or child restraint system is to be maintained or operated (excluding promotional and marketing materials, customer satisfaction surveys, and operating instructions or owner's manuals that accompany the vehicle or child restraint system at the time of first sale); or advice or direction to a dealer or distributor to cease the delivery or sale of specified models of vehicles or equipment.

Dealer field report means a field report from a dealer or authorized service facility of a manufacturer of motor vehicles or motor vehicle equipment.

Electrical system means any electrical or electronic component of a motor vehicle that is not included in one of the other reporting categories enumerated in subpart C of this part, and specifically includes the battery, battery cables, alternator, fuses, and main body wiring harnesses of the motor vehicle and the ignition system, including the ignition switch and starter motor. The term also includes all associated switches, control units, connective elements (such as wiring harnesses, hoses, piping, etc.), and mounting elements (such as brackets, fasteners, etc.).

Engine and engine cooling means the component (e.g., motor) of a motor vehicle providing motive power to the vehicle, and includes the exhaust system (including the exhaust emission system), the engine control unit, engine lubrication system, and the underhood cooling system for that engine. This term also includes all associated switches, control units, connective elements (such as wiring harnesses, hoses, piping, etc.), and mounting elements (such as brackets, fasteners, etc.).

Equipment comprises original and replacement equipment: (1) *Original equipment* means an item of motor vehicle equipment (other than a tire) that was installed in or on a motor vehicle at the time of its delivery to the first purchaser if the item of equipment was installed on or in the motor vehicle at the time of its delivery to a dealer or distributor for distribution; or the item of equipment was installed by the dealer or distributor with the express authorization of the motor vehicle manufacturer.

(2) *Replacement equipment* means motor vehicle equipment other than original equipment, and tires.

Exterior lighting mean all the exterior lamps (including any interior-mounted center highmounted stop lamp if mounted in the interior of a vehicle), lenses, reflectors, and associated equipment of a motor vehicle, including all associated switches, control units, connective elements (such as wiring harnesses, piping, etc.), and mounting elements (such as brackets, fasteners, etc.).

Field report means a communication in writing, including communications in electronic form, from an employee or representative of a manufacturer of motor vehicles or motor vehicle equipment, a dealer or authorized service facility of such manufacturer, or an entity known to the manufacturer as owning or operating a fleet, to the manufacturer regarding the failure, malfunction, lack of durability, or other performance problem of a motor vehicle or motor vehicle equipment, or any part thereof, produced for sale by that manufacturer and transported beyond the direct control of the manufacturer, regardless of whether verified or assessed to be lacking in merit, but does not include any document covered by the attorney-client privilege or the work product exclusion.

Fire means combustion or burning of material in or from a vehicle as evidenced by flame. The term also includes, but is not limited to, thermal events and fire-related phenomena such as smoke and melt, but does not include events and phenomena associated with a normally functioning vehicle such as combustion of fuel within an engine or exhaust from an engine.

Fleet means more than ten motor vehicles of the same make, model, and model year.

Foreign country means a country other than the United States.

Foreign government means the central government of a foreign country as well as any political subdivision of that country.

Fuel system means all components of a motor vehicle used to receive and store fuel, and to transfer fuel between the vehicle's fuel storage, engine, or fuel emission systems. This term in-

cludes, but is not limited to, the fuel tank and filler cap, neck, and pipe, along with associated piping, hoses, and clamps, the fuel pump, fuel lines, connectors from the fuel tank to the engine, the fuel injection/carburetion system (including fuel injector rails and injectors), and the fuel vapor recovery system(s), canister(s), and vent lines. The term also includes all associated switches, control units, connective elements (such as wiring harnesses, hoses, piping, etc.), and mounting elements (such as brackets, fasteners, etc.).

Good will means the repair or replacement of a motor vehicle or item of motor vehicle equipment, including labor, paid for by the manufacturer, at least in part, when the repair or replacement is not covered under warranty, or under a safety recall reported to NHTSA under part 573 of this chapter.

Handle means any element of a child restraint system that is designed to facilitate carrying the restraint outside a motor vehicle, other than an element of the seat shell.

Incomplete light vehicle means an incomplete vehicle as defined in §568.3 of this chapter which, when completed, will be a light vehicle.

Integrated child restraint system means a factory-installed built-in child restraint system as defined in §571.213 of this chapter and includes any factory-authorized built-in child restraint system.

Latch means a latching, locking, or linking system of a motor vehicle and all its components fitted to a vehicle's exterior doors, rear hatch, liftgate, tailgate, trunk, or hood. This term also includes, but is not limited to, devices for the remote operation of a latching device such as remote release cables (and associated components), electric release devices, or wireless control release devices, and includes all components covered in FMVSS No. 206. This term also includes all associated switches, control units, connective elements (such as wiring harnesses, hoses, piping, etc.), and mounting elements (such as brackets, fasteners, etc.).

Light vehicle means any motor vehicle, except a bus, motorcycle, or trailer, with a GVWR of 10,000 lbs or less.

Make means a name that a manufacturer applies to a group of vehicles.

Manufacturer means a person manufacturing or assembling motor vehicles or motor vehicle equipment, or importing motor vehicles or motor vehicle equipment for resale. This term includes any parent corporation, any subsidiary or affiliate, and any subsidiary or affiliate of a parent corporation of such a person.

Medium-heavy vehicle means any motor vehicle, except a trailer, with a GVWR greater than 10,000 lbs.

Minimal specificity means:

(1) For a vehicle, the make, model, and model year,

(2) For a child restraint system, the manufacturer and the model (either the model name or model number),

(3) For a tire, the manufacturer, tire line, and tire size, and

(4) For other motor vehicle equipment, the manufacturer and, if there is a model or family of models identified on the item of equipment, the model name or model number.

Model means a name that a manufacturer of motor vehicles applies to a family of vehicles within a make which have a degree of commonality in construction, such as body, chassis or cab type. For equipment other than child restraint systems, it means the name that the manufacturer uses to designate it. For child restraint systems, it means the name that the manufacturer uses to identify child restraint systems with the same seat shell, buckle, base (if so equipped) and restraint system.

Model year means the year that a manufacturer uses to designate a discrete model of vehicle, irrespective of the calendar year in which the vehicle was manufactured. If the manufacturer has not assigned a model year, it means the calendar year in which the vehicle was manufactured.

Notice means a document, other than a media article, that does not include a demand for relief, and that a manufacturer receives from a person other than NHTSA.

Other safety campaign means an action in which a manufacturer communicates with owners and/or dealers in a foreign country with respect to conditions under which motor vehicles or

equipment should be operated, repaired, or replaced that relate to safety (excluding promotional and marketing materials, customer satisfaction surveys, and operating instructions or owner's manuals that accompany the vehicle or child restraint system at the time of first sale); or advice or direction to a dealer or distributor to cease the delivery or sale of specified models of vehicles or equipment.

Parking brake means a mechanism installed in a motor vehicle which is designed to prevent the movement of a stationary motor vehicle, including all associated switches, control units, connective elements (such as wiring harnesses, hoses, piping, etc.), and mounting elements (such as brackets, fasteners, etc.).

Platform means the basic structure of a vehicle including, but not limited to, the majority of the floorpan or undercarriage, and elements of the engine compartment. The term includes a structure that a manufacturer designates as a platform. A group of vehicles sharing a common structure or chassis shall be considered to have a common platform regardless of whether such vehicles are of the same type, are of the same make, or are sold by the same manufacturer.

Power train means the components or systems of a motor vehicle which transfer motive power from the engine to the wheels, including the transmission (manual and automatic), gear selection devices and associated linkages, clutch, constant velocity joints, transfer case, driveline, differential(s), and all driven axle assemblies. This term includes all associated switches, control units, connective elements (such as wiring harnesses, hoses, piping, etc.), and mounting elements (such as brackets, fasteners, etc.).

Product evaluation report means a field report prepared by, and containing the observations or comments of, a manufacturer's employee who submitted the report concerning the operation or performance of a vehicle or child restraint system as part of the employee's personal use of the vehicle or child restraint system under a manufacturer's program authorizing such use, but does not include a report by an

employee who has been granted personal use of a vehicle or child restraint system for the specific purpose of facilitating the employee's technical or engineering evaluation of a known or suspected problem with that vehicle or child restraint system.

Production year means, for equipment and tires, the calendar year in which the item was produced.

Property damage means physical injury to tangible property.

Property damage claim means a claim for property damage, excluding that part of a claim, if any, pertaining solely to damage to a component or system of a vehicle or an item of equipment itself based on the alleged failure or malfunction of the component, system, or item, and further excluding matters addressed under warranty.

Rear-facing infant seat means a child restraint system that is designed to position a child to face only in the direction opposite to the normal direction of travel of the motor vehicle.

Reporting period means a calendar quarter of a year, unless otherwise stated.

Rollover means a single-vehicle crash in which a motor vehicle rotates on its longitudinal axis to at least 90 degrees, regardless of whether it comes to rest on its wheels.

Safety recall means an offer by a manufacturer to owners of motor vehicles or equipment in a foreign country to provide remedial action to address a defect that relates to motor vehicle safety or a failure to comply with an applicable safety standard or guideline, whether or not the manufacturer agrees to pay the full cost of the remedial action.

Seats means all components of a motor vehicle that are subject to FMVSS Nos. 202, 207, and 209, including all electrical and electronic components within the seat that are related to seat positioning, heating, and cooling. This term also includes all associated switches, control units, connective elements (such as wiring harnesses, hoses, piping, etc.), and mounting elements (such as brackets, fasteners, etc.).

Seat belts means any belt system, other than an air bag, that may or may not require the occupant to latch, fas-

ten, or secure the components of the seat belt/webbing based restraint system to ready its use for protection of the occupant in the event of a vehicle crash. This term includes the webbing, buckle, anchorage, retractor, belt pretensioner devices, load limiters, and all components, hardware and software associated with an automatic or manual seat belt system addressed by FMVSS No. 209 or 210. This term also includes integrated child restraint systems in vehicles, and includes any device (and all components of that device), installed in a motor vehicle in accordance with FMVSS No. 213, which is designed for use as a safety restraint device for a child too small to use a vehicle's seat belts. This term includes all vehicle components installed in accordance with FMVSS No. 225. This term also includes all associated switches, control units, connective elements (such as wiring harnesses, hoses, piping, etc.), and mounting elements (such as brackets, fasteners, etc.).

Seat shell means the portion of a child restraint system that provides the structural shape, form and support for the system, and for other components of the system such as belt attachment points, and anchorage points to allow the system to be secured to a passenger seat in a motor vehicle, but not including a shield.

Service brake system means all components of the service braking system of a motor vehicle intended for the transfer of braking application force from the operator to the wheels of a vehicle, including the foundation braking system, such as the brake pedal, master cylinder, fluid lines and hoses, braking assist components, brake calipers, wheel cylinders, brake discs, brake drums, brake pads, brake shoes, and other related equipment installed in a motor vehicle in order to comply with FMVSS Nos. 105, 121, 122, or 135 (except equipment relating specifically to a parking brake). This term also includes systems and devices for automatic control of the brake system such as antilock braking, traction control, stability control, and enhanced braking. The term includes all associated switches, control units, connective elements (such as wiring harnesses, hoses,

pipng, etc.), and mounting elements (such as brackets, fasteners, etc.).

Sidewall means the area of a tire between the tread and the bead area, including the sidewall rubber components, the body ply and its coating rubber under the side area, and the inner-liner rubber under the body ply in the side area.

SKU (Stock Keeping Unit) means the alpha-numeric designation assigned by a manufacturer to uniquely identify a tire product. This term is sometimes referred to as a product code, a product ID, or a part number.

Steering system means all steering control system components, including the steering system mechanism and its associated hardware, the steering wheel, steering column, steering shaft, linkages, joints (including tie-rod ends), steering dampeners, and power steering assist systems. This term includes a steering control system as defined by FMVSS No. 203 and any subsystem or component of a steering control system, including those components defined in FMVSS No. 204. This term also includes all associated switches, control units, connective elements (such as wiring harnesses, hoses, piping, etc.), and mounting elements (such as brackets, fasteners, etc.).

Structure means any part of a motor vehicle that serves to maintain the shape and size of the vehicle, including the frame, the floorpan, the body, bumpers, doors, tailgate, hatchback, trunk lid, hood, and roof. The term also includes all associated mounting elements (such as brackets, fasteners, etc.).

Suspension system means all components and hardware associated with a motor vehicle suspension system, including the associated control arms, steering knuckles, spindles, joints, bushings, ball joints, springs, shock absorbers, stabilizer (anti sway) bars, and bearings that are designed to minimize the impact on the vehicle chassis of shocks from road surface irregularities that may be transmitted through the wheels, and to provide stability when the vehicle is being operated through a range of speed, load, and dynamic conditions. The term also includes all electronic control systems and mechanisms for active suspension control, as

well as all associated components such as switches, control units, connective elements (such as wiring harnesses, hoses, piping, etc.), and mounting elements (such as brackets, fasteners, etc.).

Tire means an item of motor vehicle equipment intended to interface between the road and a motor vehicle. The term includes all the tires of a vehicle, including the spare tire. For purposes of §§579.21 through 579.24 and §579.27 of this part, this term also includes the tire inflation valves, tubes, and tire pressure monitoring and regulating systems, as well as all associated switches, control units, connective elements (such as wiring harnesses, hoses, piping, etc.), and mounting elements (such as brackets, fasteners, etc.).

Tire line means the entire name used by a tire manufacturer to designate a tire product including all prefixes and suffixes as they appear on the sidewall of a tire.

Trailer hitch means all coupling systems, devices, and components thereof, designed to join or connect any two motor vehicles. This term also includes all associated switches, control units, connective elements (such as wiring harnesses, hoses, piping, etc.), and mounting elements (such as brackets, fasteners, etc.).

Tread (also known as crown) means all materials in the tread area of a tire including the rubber that makes up the tread, the sub-base rubber, when present, between the tread base and the top of the belts, the belt material, either steel and/or fabric, and the rubber coating of the same including any rubber inserts, the body ply and its coating rubber under the tread area of the tire, and the inner-liner rubber under the tread.

Type means, in the context of a light vehicle, a vehicle certified by its manufacturer pursuant to §567.4(g)(7) of this chapter as a passenger car, multipurpose passenger vehicle, or truck, or a vehicle identified by its manufacturer as an incomplete vehicle pursuant to §568.4 of this chapter. In the context of a medium heavy vehicle and bus, it means one of the following categories: Truck, tractor, transit bus, school bus, coach, recreational vehicle, emergency

vehicle, or other. In the context of a trailer, it means one of the following categories: Recreational trailers, van trailers, flatbed trailer, trailer converter dolly, lowbed trailer, dump trailer, tank trailer, dry bulk trailer, livestock trailer, boat trailer, auto transporter, or other. In the context of a child restraint system, it means the category of child restraint system selected from one of the following: rear-facing infant seat, booster seat, or other.

Vehicle speed control means the systems and components of a motor vehicle that control vehicle speed either by command of the operator or by automatic control, including, but not limited, to the accelerator pedal, linkages, cables, springs, speed control devices (such as cruise control) and speed limiting devices. This term includes, but is not limited to the items addressed by FMVSS No. 124 and all associated switches, control units, connective elements (such as wiring harnesses, hoses, piping, etc.), and mounting elements (such as brackets, fasteners, etc.).

Visibility means the systems and components of a motor vehicle through which a driver views the surroundings of the vehicle including windshield, side windows, back window, and rear view mirrors, and systems and components used to wash and wipe windshields and back windows. This term includes those vehicular systems and components that can affect the ability of the driver to clearly see the roadway and surrounding area, such as the systems and components identified in FMVSS Nos. 103, 104, and 111. This term also includes the defogger/defroster system, the heater core, blower fan, windshield wiper systems, mirrors, windows and glazing material, heads-up display (HUD) systems, and exterior view-based television systems, but does not include exterior lighting systems which are defined under “Lighting.” This term includes all associated switches, control units, connective elements (such as wiring harnesses, hoses, piping, etc.), and mounting elements (such as brackets, fasteners, etc.).

Warranty means any written affirmation of fact or written promise made in connection with the sale or lease of a motor vehicle or motor vehicle equip-

ment by a manufacturer to a buyer or lessee that relates to the nature of the material or workmanship and affirms or promises that such material or workmanship is defect free or will meet a specified level of performance over a specified period of time (including any extensions of such specified period of time), or any undertaking in writing in connection with the sale or lease by a manufacturer of a motor vehicle or item of motor vehicle equipment to refund, repair, replace, or take other remedial action with respect to such product in the event that such product fails to meet the specifications set forth in the undertaking.

Warranty adjustment means any payment or other restitution, such as, but not limited to, replacement, repair, credit, or cash refund, made by a tire manufacturer to a consumer or to a dealer, in reimbursement for payment or other restitution to a consumer, pursuant to a warranty program offered by the manufacturer or goodwill.

Warranty claim means any claim paid by a manufacturer, including provision of a credit, pursuant to a warranty program, an extended warranty program, or good will. It does not include claims for reimbursement for costs or related expenses for work performed to remedy a safety-related defect or noncompliance reported to NHTSA under part 573 of this chapter, or in connection with a motor vehicle emissions-related recall under the Clean Air Act or in accordance with State law as authorized under 42 U.S.C. 7543(b) or 7507.

Wheel means the assembly or component of a motor vehicle to which a tire is mounted. The term includes any item of motor vehicle equipment used to attach the wheel to the vehicle, including inner cap nuts and the wheel studs, bolts, and nuts.

Work product means a document in the broad sense of the word, prepared in anticipation of litigation where there is a reasonable prospect of litigation and not for some other purpose such as a business practice, and prepared or requested by an attorney or an agent for an attorney.

(d) *Identical or substantially similar motor vehicle, item of motor vehicle equipment, or tire.* (1) A motor vehicle sold or in use outside the United States is

identical or substantially similar to a motor vehicle sold or offered for sale in the United States if—

(i) Such a vehicle has been sold in Canada or has been certified as complying with the Canadian Motor Vehicle Safety Standards;

(ii) Such a vehicle is listed in the VSP or VSA columns of appendix A to part 593 of this chapter;

(iii) Such a vehicle is manufactured in the United States for sale in a foreign country; or

(iv) Such a vehicle uses the same vehicle platform as a vehicle sold or offered for sale in the United States.

(2) An item of motor vehicle equipment sold or in use outside the United States is identical or substantially similar to equipment sold or offered for sale in the United States if such equipment and the equipment sold or offered for sale in the United States have one or more components or systems that are the same, and the component or system performs the same function in vehicles or equipment sold or offered for sale in the United States, regardless of whether the part numbers are identical.

(3) A tire sold or in use outside the United States is substantially similar to a tire sold or offered for sale in the United States if it has the same size, speed rating, load index, load range, number of plies and belts, and similar ply and belt construction and materials, placement of components, and component materials, irrespective of plant of manufacture or tire line.

[43 FR 38833, Aug. 31, 1978, as amended at 67 FR 63310, Oct. 11, 2002; 68 FR 4113, Jan. 28, 2003; 68 FR 18142, Apr. 15, 2003; 68 FR 35142, June 11, 2003; 69 FR 20557, Apr. 16, 2004; 72 FR 29443, May 29, 2007; 74 FR 47757, Sept. 17, 2009]

§ 579.5 Notices, bulletins, customer satisfaction campaigns, consumer advisories, and other communications.

(a) Each manufacturer shall furnish to NHTSA's Early Warning Division (NVS-217) a copy of all notices, bulletins, and other communications (including those transmitted by computer, telefax, or other electronic means and including warranty and policy extension communiqués and product improvement bulletins) other than

those required to be submitted pursuant to § 573.6(c)(10) of this chapter, sent to more than one manufacturer, distributor, dealer, lessor, lessee, owner, or purchaser, in the United States, regarding any defect in its vehicles or items of equipment (including any failure or malfunction beyond normal deterioration in use, or any failure of performance, or any flaw or unintended deviation from design specifications), whether or not such defect is safety-related.

(b) Each manufacturer shall furnish to NHTSA a copy of each communication relating to a customer satisfaction campaign, consumer advisory, recall, or other safety activity involving the repair or replacement of motor vehicles or equipment, that the manufacturer issued to, or made available to, more than one dealer, distributor, lessor, lessee, other manufacturer, owner, or purchaser, in the United States.

(c) If a notice or communication is required to be submitted under both paragraphs (a) and (b) of this section, it need only be submitted once.

(d) Each copy shall be in readable form and shall be submitted not later than five working days after the end of the month in which it is issued. However, a document described in paragraph (b) of this section and issued before July 1, 2003, need not be submitted.

[67 FR 45873, July 10, 2002, as amended at 68 FR 18142, Apr. 15, 2003; 68 FR 35147, June 11, 2003; 69 FR 49823, Aug. 12, 2004; 72 FR 32017, June 11, 2007]

§ 579.6 Address for submitting reports and other information.

(a) Except as provided by paragraph (b) of this section, information, reports, and documents required to be submitted to NHTSA pursuant to this part may be submitted by mail, by facsimile, or by e-mail. If submitted by mail, they must be addressed to the Associate Administrator for Enforcement, National Highway Traffic Safety Administration, Attention: Early Warning Division (NVS-217), 1200 New Jersey Avenue, SE., Washington, DC 20590. If submitted by facsimile, they must be addressed to the Associate Administrator for Enforcement and transmitted to (202) 366-7882. If submitted by

e-mail, submissions under subpart B of this part must be submitted to *frecalls@dot.gov* and submissions under § 579.5 must be submitted to *tsb@dot.gov*.

(b) Information, documents and reports that are submitted to NHTSA's early warning data repository must be submitted in accordance with § 579.29 of this part. Submissions must be made by a means that permits the sender to verify that the report was in fact received by NHTSA and the day it was received by NHTSA.

[68 FR 4113, Jan. 28, 2003, as amended at 72 FR 32017, June 11, 2007]

§§ 579.7–579.10 [Reserved]

Subpart B—Reporting of Safety Recalls and Other Safety Campaigns in Foreign Countries

SOURCE: 67 FR 63310, Oct. 11, 2002, unless otherwise noted.

§ 579.11 Reporting responsibilities.

(a) *Determination by a manufacturer.* Not later than 5 working days after a manufacturer determines to conduct a safety recall or other safety campaign in a foreign country covering a motor vehicle, item of motor vehicle equipment, or tire that is identical or substantially similar to a vehicle, item of equipment, or tire sold or offered for sale in the United States, the manufacturer shall report the determination to NHTSA. For purposes of this paragraph, this period is determined by reference to the general business practices of the office in which such determination is made, and the office reporting to NHTSA.

(b) *Determination by a foreign government.* Not later than 5 working days after a manufacturer receives written notification that a foreign government has determined that a safety recall or other safety campaign must be conducted in its country with respect to a motor vehicle, item of motor vehicle equipment, or tire that is identical or substantially similar to a vehicle, item of equipment, or tire sold or offered for sale in the United States, the manufacturer shall report the determination to NHTSA. For purposes of this para-

graph, this period is determined by reference to the general business practices of the office where the manufacturer receives such notification, the manufacturer's international headquarters office (if involved), and the office reporting to NHTSA.

(c) *One-time historical reporting.* Not later than 30 calendar days after November 12, 2002, a manufacturer that has made a determination to conduct a recall or other safety campaign in a foreign country, or that has received written notification that a foreign government has determined that a safety recall or other safety campaign must be conducted in its country in the period between November 1, 2000 and November 12, 2002, and that has not reported such determination or notification of determination to NHTSA in a report that identified the model(s) and model year(s) of the vehicles, equipment, or tires that were the subject of the foreign recall or other safety campaign, the model(s) and model year(s) of the vehicles, equipment, or tires that were identical or substantially similar to the subject of the recall or campaign, and the defect or other condition that led to the foreign recall or campaign, as of November 12, 2002, shall report such determination or notification of determination to NHTSA if the safety recall or other safety campaign covers a motor vehicle, item of motor vehicle equipment, or tire that is identical or substantially similar to a vehicle, item of equipment, or tire sold or offered for sale in the United States. However, a report need not be resubmitted under this paragraph if the original report identified the model(s) and model year(s) of the vehicles, equipment, or tires that were the subject of the foreign recall or other safety campaign, identified the model(s) and model year(s) of the identical or substantially similar products in the United States, and identified the defect or other condition that led to the foreign recall or other safety campaign.

(d) *Exemptions from reporting.* Notwithstanding paragraphs (a), (b), and (c) of this section a manufacturer need not report a foreign safety recall or other safety campaign to NHTSA if:

(1) The manufacturer has determined that for the same or substantially similar reasons relating to motor vehicle safety that it is conducting a safety recall or other safety campaign in a foreign country, a safety-related defect or noncompliance with a Federal motor vehicle safety standard exists in identical or substantially similar motor vehicles, motor vehicle equipment, or tires sold or offered for sale in the United States, and has filed a defect or noncompliance information report pursuant to part 573 of this chapter, provided that the scope of the foreign recall or campaign is not broader than the scope of the recall campaign in the United States;

(2) The component or system that gave rise to the foreign recall or other campaign does not perform the same function in any substantially similar vehicles or equipment sold or offered for sale in the United States; or

(3) The sole subject of the foreign recall or other campaign is a label affixed to a vehicle, item of equipment, or a tire.

(e) *Annual list of substantially similar vehicles.* Not later than November 1 of each year, each manufacturer of motor vehicles that sells or offers a motor vehicle for sale in the United States shall submit to NHTSA a document that identifies both each model of motor vehicle that the manufacturer sells or plans to sell during the following year in a foreign country that the manufacturer believes is identical or substantially similar to a motor vehicle sold or offered for sale in the United States (or to a motor vehicle that is planned for sale in the United States in the following year), and each such identical or substantially similar motor vehicle sold or offered for sale in the United States. Not later than 30 days after January 28, 2003, each manufacturer to which this paragraph applies shall submit an initial annual list of vehicles for calendar year 2003 that meets the requirements of this paragraph.

[67 FR 63310, Oct. 11, 2002, as amended at 68 FR 4113, Jan. 28, 2003]

§ 579.12 Contents of reports.

(a) Each report made pursuant to § 579.11 of this part must be dated and must include the information specified

in § 573.6(c)(1), (c)(2), (c)(3), and (c)(5) of this chapter. Each such report must also identify each foreign country in which the safety recall or other safety campaign is being conducted, state whether the foreign action is a safety recall or other safety campaign, state whether the determination to conduct the recall or campaign was made by the manufacturer or by a foreign government, describe the manufacturer's program for remedying the defect or noncompliance (if the action is a safety recall), specify the date of the determination and the date the recall or other campaign was commenced or will commence in each foreign country, and identify all motor vehicles, equipment, or tires that the manufacturer sold or offered for sale in the United States that are identical or substantially similar to the motor vehicles, equipment, or tires covered by the foreign recall or campaign. If a determination has been made by a foreign government, the report must also include a copy of the determination in the original language and, if the determination is in a language other than English, a copy translated into English.

(b) Information required by paragraph (a) of this section that is not available within the 5-working day period specified in § 579.11 of this part shall be submitted as it becomes available.

§§ 579.13–579.20 [Reserved]

Subpart C—Reporting of Early Warning Information

§ 579.21 Reporting requirements for manufacturers of 5,000 or more light vehicles annually.

For each reporting period, a manufacturer whose aggregate number of light vehicles manufactured for sale, sold, offered for sale, introduced or delivered for introduction in interstate commerce, or imported into the United States, during the calendar year of the reporting period or during each of the prior two calendar years is 5,000 or more shall submit the information described in this section. For paragraphs (a) and (c) of this section, the manufacturer shall submit information separately with respect to each make,

model, and model year of light vehicle manufactured during the reporting period and the nine model years prior to the earliest model year in the reporting period, including models no longer in production.

(a) *Production information.* Information that states the manufacturer's name, the quarterly reporting period, the make, the model, the model year, the type, the platform, and the production. The production shall be stated as either the cumulative production of the current model year to the end of the reporting period, or the total model year production for each model year for which production has ceased.

(b) *Information on incidents involving death or injury.* For all light vehicles manufactured during a model year covered by the reporting period and the nine model years prior to the earliest model year in the reporting period:

(1) A report on each incident involving one or more deaths or injuries occurring in the United States that is identified in a claim against and received by the manufacturer or in a notice received by the manufacturer which notice alleges or proves that the death or injury was caused by a possible defect in the manufacturer's vehicle, together with each incident involving one or more deaths occurring in a foreign country that is identified in a claim against and received by the manufacturer involving the manufacturer's vehicle, if that vehicle is identical or substantially similar to a vehicle that the manufacturer has offered for sale in the United States. The report shall be submitted as a report on light vehicles and organized such that incidents are reported alphabetically by make, within each make alphabetically by model, and within each model chronologically by model year.

(2) For each incident described in paragraph (b)(1) of this section, the manufacturer shall separately report the make, model, model year, and VIN of the vehicle, the incident date, the number of deaths, the number of injuries for incidents occurring in the United States, the State or foreign country where the incident occurred, each system or component of the vehicle that allegedly contributed to the incident, and whether the incident in-

volved a fire or rollover, coded as follows: 01 steering system, 02 suspension system, 03 service brake system, 05 parking brake, 06 engine and engine cooling system, 07 fuel system, 10 power train, 11 electrical system, 12 exterior lighting, 13 visibility, 14 air bags, 15 seat belts, 16 structure, 17 latch, 18 vehicle speed control, 19 tires, 20 wheels, 22 seats, 23 fire, 24 rollover, 98 where a system or component not covered by categories 01 through 22 is specified in the claim or notice, and 99 where no system or component of the vehicle is specified in the claim or notice. If an incident involves more than one such code, each shall be reported separately in the report with a limit of five codes to be included.

(c) *Numbers of property damage claims, consumer complaints, warranty claims, and field reports.* Separate reports on the numbers of those property damage claims, consumer complaints, warranty claims, and field reports which involve the systems and components that are specified in codes 01 through 22 in paragraph (b)(2) of this section, or a fire (code 23), or rollover (code 24). Each such report shall state, separately by each such code, the number of such property damage claims, consumer complaints, warranty claims, or field reports, respectively, that involves the systems or components or fire or rollover indicated by the code. If an underlying property damage claim, consumer complaint, warranty claim, or field report involves more than one such code, each shall be reported separately in the report with no limit on the number of codes to be included. No reporting is necessary if the system or component involved is not specified in such codes, and the incident did not involve a fire or rollover.

(d) *Copies of field reports.* For all light vehicles manufactured during a model year covered by the reporting period and the nine model years prior to the earliest model year in the reporting period, a copy of each field report (other than a dealer report or a product evaluation report) involving one or more of the systems or components identified in paragraph (b)(2) of this section, or

fire, or rollover, containing any assessment of an alleged failure, malfunction, lack of durability, or other performance problem of a motor vehicle or item of motor vehicle equipment (including any part thereof) that is originated by an employee or representative of the manufacturer and that the manufacturer received during a reporting period. These documents shall be submitted alphabetically by make, within each make alphabetically by model, and within each model chronologically by model year. For purposes of this paragraph, if a field report refers to more than one make or model of light vehicle produced by a manufacturer on a particular platform, the manufacturer shall submit the report alphabetically by platform rather than by make or model. If such a field report refers to more than one platform, separate copies shall be submitted for each such platform. If a field report refers to more than one model year of a specified make/model or platform, the manufacturer shall submit it by the earliest model year to which it refers.

[67 FR 45873, July 10, 2002, as amended at 68 FR 18142, Apr. 15, 2003; 68 FR 35142, June 11, 2003; 72 FR 29443, May 29, 2007; 74 FR 47757, Sept. 17, 2009]

§ 579.22 Reporting requirements for manufacturers of 100 or more buses, manufacturers of 500 or more emergency vehicles and manufacturers of 5,000 or more medium-heavy vehicles (other than buses and emergency vehicles) annually.

For each reporting period, a manufacturer whose aggregate number of buses manufactured for sale, sold, offered for sale, introduced or delivered for introduction in interstate commerce, or imported into the United States, during the calendar year of the reporting period or during either of the prior two calendar years is 100 or more shall submit the information described in this section. For each reporting period, a manufacturer whose aggregate number of emergency vehicles (ambulances and fire trucks) manufactured for sale, sold, offered for sale, introduced or delivered for introduction in interstate commerce, or imported into the United States, during the calendar year of the reporting period or during

either of the prior two calendar years is 500 or more shall submit the information described in this section. For each reporting period, a manufacturer whose aggregate number of medium-heavy vehicles (a sum that does not include buses or emergency vehicles) manufactured for sale, sold, offered for sale, introduced or delivered for introduction in interstate commerce, or imported into the United States, during the calendar year of the reporting period or during either of the prior two calendar years is 5,000 or more shall submit the information described in this section. For paragraphs (a) and (c) of this section, the manufacturer shall submit information separately with respect to each make, model, and model year of bus, emergency vehicle and/or medium-heavy vehicle manufactured during the reporting period and the nine model years prior to the earliest model year in the reporting period, including models no longer in production.

(a) *Production information.* Information that states the manufacturer's name, the quarterly reporting period, the make, the model, the model year, the type, and the production. The production shall be stated as either the cumulative production of the current model year to the end of the reporting period, or the total model year production for each model year for which production has ceased. For each model that is manufactured and available with more than one type of fuel system (i.e., gasoline, diesel, or other (including vehicles that can be operated using more than one type of fuel, such as gasoline and compressed natural gas)), the information required by this subsection shall be reported separately by each of the three fuel system types. For each model that is manufactured and available with more than one type of service brake system (i.e., hydraulic or air), the information required by this subsection shall be reported by each of the two brake types. If the service brake system in a vehicle is not readily characterized as either hydraulic or air, the vehicle shall be considered to have hydraulic service brakes.

(b) *Information on incidents involving death or injury.* For all buses, emergency vehicles and medium heavy vehicles manufactured during a model year covered by the reporting period and the nine model years prior to the earliest model year in the reporting period:

(1) A report on each incident involving one or more deaths or injuries occurring in the United States that is identified in a claim against and received by the manufacturer or in a notice received by the manufacturer which notice alleges or proves that the death or injury was caused by a possible defect in the manufacturer's vehicle, together with each incident involving one or more deaths occurring in a foreign country that is identified in a claim against and received by the manufacturer involving the manufacturer's vehicle, if that vehicle is identical or substantially similar to a vehicle that the manufacturer has offered for sale in the United States. The report shall be submitted as a report on medium-heavy vehicles and buses and organized such that incidents are reported alphabetically by make, within each make alphabetically by model, and within each model chronologically by model year.

(2) For each incident described in paragraph (b)(1) of this section, the manufacturer shall separately report the make, model, model year, and VIN of the medium-heavy vehicle or bus, the incident date, the number of deaths, the number of injuries for incidents occurring in the United States, the State or foreign country where the incident occurred, each system or component of the vehicle that allegedly contributed to the incident, and whether the incident involved a fire or rollover, coded as follows: 01 steering system, 02 suspension system, 03 service brake system, hydraulic, 04 service brake system, air, 05 parking brake, 06 engine and engine cooling system, 07 fuel system, gasoline, 08 fuel system, diesel, 09 fuel system, other, 10 power train, 11 electrical, 12 exterior lighting, 13 visibility, 14 air bags, 15 seat belts, 16 structure, 17 latch, 18 vehicle speed control, 19 tires, 20 wheels, 21 trailer hitch, 22 seats, 23 fire, 24 rollover, 98 where a system or component not covered by categories 01 through 22 is

specified in the claim or notice, and 99 where no system or component of the vehicle is specified in the claim or notice. If an incident involves more than one such code, each shall be reported separately in the report with a limit of five codes to be included.

(c) *Numbers of property damage claims, consumer complaints, warranty claims, and field reports.* Separate reports on the numbers of those property damage claims, consumer complaints, warranty claims, and field reports which involve the systems and components that are specified in codes 01 through 22 in paragraph (b)(2) of this section, or a fire (code 23), or rollover (code 24). Each such report shall state, separately by each such code, the number of such property damage claims, consumer complaints, warranty claims, or field reports, respectively, that involves the systems or components or fire or rollover indicated by the code. If an underlying property damage claim, consumer complaint, warranty claim, or field report involves more than one such code, each shall be reported separately in the report with no limit on the number of codes to be included. No reporting is necessary if the system or component involved is not specified in such codes, and the incident did not involve a fire or rollover.

(d) *Copies of field reports.* For all medium heavy vehicles and buses manufactured during a model year covered by the reporting period and the nine model years prior to the earliest model year in the reporting period, a copy of each field report (other than a dealer report or a product evaluation report) involving one or more of the systems or components identified in paragraph (b)(2) of this section, or fire, or rollover, containing any assessment of an alleged failure, malfunction, lack of durability, or other performance problem of a motor vehicle or item of motor vehicle equipment (including any part thereof) that is originated by an employee or representative of the manufacturer and that the manufacturer received during a reporting period. These documents shall be submitted alphabetically by make, within each make alphabetically by model, and within each model chronologically by model year. For purposes of this

paragraph, if a field report refers to more than one make or model of vehicle produced by a manufacturer on a particular platform, the manufacturer shall submit the report alphabetically by platform rather than by make or model. If such a field report refers to more than one platform, separate copies shall be submitted for each such platform. If a field report refers to more than one model year of a specified make/model or platform, the manufacturer shall submit it by the earliest model year to which it refers.

[67 FR 45873, July 10, 2002, as amended at 68 FR 18142, Apr. 15, 2003; 68 FR 35143, June 11, 2003; 72 FR 29443, May 29, 2007; 74 FR 47757, Sept. 17, 2009]

§ 579.23 Reporting requirements for manufacturers of 5,000 or more motorcycles annually.

For each reporting period, a manufacturer whose aggregate number of motorcycles manufactured for sale, sold, offered for sale, introduced or delivered for introduction in interstate commerce, or imported into the United States, during the calendar year of the reporting period or during either of the prior two calendar years is 5,000 or more shall submit the information described in this section. For paragraphs (a) and (c) of this section, the manufacturer shall submit information separately with respect to each make, model, and model year of motorcycle manufactured during the reporting period and the nine model years prior to the earliest model year in the reporting period, including models no longer in production.

(a) *Production information.* Information that states the manufacturer's name, the quarterly reporting period, the make, the model, the model year, and the production. The production shall be stated as either the cumulative production of the current model year to the end of the reporting period, or the total model year production for each model year for which production has ceased.

(b) *Information on incidents involving death or injury.* For all motorcycles manufactured during a model year covered by the reporting period and the nine model years prior to the earliest model year in the reporting period:

(1) A report on each incident involving one or more deaths or injuries occurring in the United States that is identified in a claim against and received by the manufacturer or in a notice received by the manufacturer which notice alleges or proves that the death or injury was caused by a possible defect in the manufacturer's motorcycle, together with each incident involving one or more deaths occurring in a foreign country that is identified in a claim against and received by the manufacturer involving the manufacturer's motorcycle, if that motorcycle is identical or substantially similar to a motorcycle that the manufacturer has offered for sale in the United States. The report shall be submitted as a report on motorcycles and organized such that incidents are reported alphabetically by make, within each make alphabetically by model, and within each model chronologically by model year.

(2) For each incident described in paragraph (b)(1) of this section, the manufacturer shall separately report the make, model, model year, and VIN of the motorcycle, the incident date, the number of deaths, the number of injuries for incidents occurring in the United States, the State or foreign country where the incident occurred, each system or component of the motorcycle that allegedly contributed to the incident, and whether the incident involved a fire, coded as follows: 01 steering, 02 suspension, 03 service brake system, 06 engine and engine cooling, 07 fuel system, 10 power train, 11 electrical, 12 exterior lighting, 16 structure, 18 vehicle speed control, 19 tires, 20 wheels, 23 fire, 98 where a system or component not covered by categories 01 through 20 is specified in the claim or notice, and 99 where no system or component of the vehicle is specified in the claim or notice. If an incident involves more than one such code, each shall be reported separately in the report with a limit of five codes to be included.

(c) *Numbers of property damage claims, consumer complaints, warranty claims, and field reports.* Separate reports on the numbers of those property damage claims, consumer complaints, warranty claims, and field reports which involve

§579.24

the systems and components that are specified in codes 01 through 20 in paragraph (b)(2) of this section, or a fire (code 23). Each such report shall state, separately by each such code, the number of such property damage claims, consumer complaints, warranty claims, or field reports, respectively, that involves the systems or components or fire indicated by the code. If an underlying property damage claim, consumer complaint, warranty claim, or field report involves more than one such code, each shall be reported separately in the report with no limit on the number of codes to be included. No reporting is necessary if the system or component involved is not specified in such codes, and the incident did not involve a fire.

(d) *Copies of field reports.* For all motorcycles manufactured during a model year covered by the reporting period and the nine model years prior to the earliest model year in the reporting period, a copy of each field report (other than a dealer report or a product evaluation report) involving one or more of the systems or components identified in paragraph (b)(2) of this section or fire, containing any assessment of an alleged failure, malfunction, lack of durability, or other performance problem of a motorcycle or item of motor vehicle equipment (including any part thereof) that is originated by an employee or representative of the manufacturer and that the manufacturer received during a reporting period. These documents shall be submitted alphabetically by make, within each make alphabetically by model, and within each model chronologically by model year. For purposes of this paragraph, if a field report refers to more than one make or model of motorcycle produced by a manufacturer on a particular platform, the manufacturer shall submit the report alphabetically by platform rather than by make or model. If such a field report refers to more than one platform, separate copies shall be submitted for each such platform. If a field report refers to more than one model year of a specified make/model or platform, the manufacturer shall

49 CFR Ch. V (10–1–10 Edition)

submit it by the earliest model year to which it refers.

[67 FR 45873, July 10, 2002, as amended at 68 FR 18142, Apr. 15, 2003; 68 FR 35143, June 11, 2003; 72 FR 29443, May 29, 2007; 74 FR 47758, Sept. 17, 2009]

§579.24 Reporting requirements for manufacturers of 5,000 or more trailers annually.

For each reporting period, a manufacturer whose aggregate number of trailers manufactured for sale, sold, offered for sale, introduced or delivered for introduction in interstate commerce, or imported into the United States, during the calendar year of the reporting period or during either of the prior two calendar years is 5,000 or more shall submit the information described in this section. For paragraphs (a) and (c) of this section, the manufacturer shall submit information with respect to each make, model and model year of trailer manufactured during the reporting period and the nine model years prior to the earliest model year in the reporting period, including models no longer in production.

(a) *Production information.* Information that states the manufacturer's name, the quarterly reporting period, the make, the model, the model year, the type, and the production. The production shall be stated as either the cumulative production of the current model year to the end of the reporting period, or the total model year production for each model year for which production has ceased. For each model that is manufactured and available with more than one type of service brake system (*i.e.*, hydraulic and air), the information required by this subsection shall be reported by each of the two brake types (*i.e.*, "H" for hydraulic, "A" for air). If the service brake system in a trailer is not readily characterized as either hydraulic or air, the trailer shall be considered to have hydraulic service brakes. If a model has no brake system, it shall be reported as "N," for none.

(b) *Information on incidents involving death or injury.* For all trailers manufactured during a model year covered by the reporting period and the nine model years prior to the earliest model year in the reporting period:

(1) A report on each incident involving one or more deaths or injuries occurring in the United States that is identified in a claim against and received by the manufacturer or in a notice received by the manufacturer which notice alleges or proves that the death or injury was caused by a possible defect in the manufacturer's trailer, together with each incident involving one or more deaths occurring in a foreign country that is identified in a claim against and received by the manufacturer involving the manufacturer's trailer, if that trailer is identical or substantially similar to a trailer that the manufacturer has offered for sale in the United States. The report shall be submitted as a report on trailers and organized such that incidents are reported alphabetically by make, with each make alphabetically by model, and within each model chronologically by model year.

(2) For each incident described in paragraph (b)(1) of this section, the manufacturer shall separately report the make, model, model year, and VIN of the trailer, the incident date, the number of deaths, the number of injuries for incidents occurring in the United States, the State or foreign country where the incident occurred, each system or component of the trailer that allegedly contributed to the incident, and whether the incident involved a fire, coded as follows: 02 suspension, 03 service brake system, hydraulic, 04 service brake system, air, 05 parking brake, 11 electrical, 12 exterior lighting, 16 structure, 17 latch, 19 tires, 20 wheels, 21 trailer hitch, 23 fire, 98 where a system or component not covered by categories 02 through 21 is specified in the claim or notice, and 99 where no system or component of the trailer is specified in the claim or notice. If an incident involves more than one such code, each shall be reported separately in the report with a limit of five codes to be included.

(c) *Numbers of property damage claims, consumer complaints, warranty claims, and field reports.* Separate reports on the numbers of those property damage claims, consumer complaints, warranty claims, and field reports which involve the systems and components that are specified in codes 02 through 21 in para-

graph (b)(2) of this section, or a fire (code 23). Each such report shall state, separately by each such code, the number of such property damage claims, consumer complaints, warranty claims, or field reports, respectively, that involves the systems or components or fire indicated by the code. If an underlying property damage claim, consumer complaint, warranty claim, or field report involves more than one such code, each shall be reported separately in the report with no limit on the number of codes to be included. No reporting is necessary if the system or component involved is not specified in such codes, and the incident did not involve a fire.

(d) *Copies of field reports.* For all trailers manufactured during a model year covered by the reporting period and the nine model years prior to the earliest model year in the reporting period, a copy of each field report (other than a dealer report or a product evaluation report) involving one or more of the systems or components identified in paragraph (b)(2) of this section or fire, containing any assessment of an alleged failure, malfunction, lack of durability, or other performance problem of a trailer or item of motor vehicle equipment (including any part thereof) that is originated by an employee or representative of the manufacturer and that the manufacturer received during a reporting period. These documents shall be submitted alphabetically by make, within each make alphabetically by model, and within each model chronologically by model year. For purposes of this paragraph, if a field report refers to more than one make or model of trailer produced by a manufacturer on a particular platform, the manufacturer shall submit the report alphabetically by platform rather than by make or model. If such a field report refers to more than one platform, separate copies shall be submitted for each such platform. If a field report refers to more than one model year of a specified make/model or platform, the manufacturer shall submit it by the earliest model year to which it refers.

[67 FR 45873, July 10, 2003, as amended at 68 FR 18143, Apr. 15, 2003; 68 FR 35143, June 11, 2003; 72 FR 29443, May 29, 2007; 74 FR 47758, Sept. 17, 2009]

§ 579.25 Reporting requirements for manufacturers of child restraint systems.

For each reporting period, a manufacturer who has manufactured for sale, sold, offered for sale, introduced or delivered for introduction in interstate commerce, or imported child restraint systems into the United States, shall submit the information described in this section. For paragraphs (a) and (c) of this section, the manufacturer shall submit information separately with respect to each make, model, and production year of child restraint system manufactured during the reporting period and the four production years prior to the earliest production year in the reporting period, including models no longer in production. For paragraph (c) of this section, if any consumer complaints or warranty claims regarding a model of child restraint system do not specify the production year of the system, the manufacturer shall submit information for “unknown” production year in addition to the up-to-five production years for which the manufacturer must otherwise report the number of such consumer complaints/warranty claims.

(a) *Production information.* Information that states the manufacturer’s name, the quarterly reporting period, the make, the model, the production year, the type, and the production. The production shall be stated as either the cumulative production of the current model year to the end of the reporting period, or the total calendar year production for each calendar year for which production has ceased.

(b) *Information on incidents involving death or injury.* For all child restraint systems manufactured during a production year covered by the reporting period and the four production years prior to the earliest production year in the reporting period:

(1) A report on each incident involving one or more deaths or injuries occurring in the United States that is identified in a claim against and received by the manufacturer or in a notice received by the manufacturer which notice alleges or proves that the death or injury was caused by a possible defect in the manufacturer’s child restraint system, together with each

incident involving one or more deaths occurring in a foreign country that is identified in a claim against and received by the manufacturer involving the manufacturer’s child restraint system, if the child restraint system is identical or substantially similar to a child restraint system that the manufacturer has offered for sale in the United States. The report shall be submitted as a report on child restraint systems and organized such that incidents are reported alphabetically by make, within each make alphabetically by model, and within each model chronologically by production year.

(2) For each such incident described in paragraph (b)(1) of this section, the manufacturer shall separately report the make, model, and production year of the child restraint system, the incident date, the number of deaths, the number of injuries for incidents occurring in the United States, the State or foreign country where the incident occurred, and each system or component of the child restraint system that allegedly contributed to the incident, coded as follows: 51 buckle and restraint harness, 52 seat shell, 53 handle, 54 base, 98 where a system or component not covered by categories 51 through 54 is specified in the claim or notice, and 99 where no system or component of the child restraint system is specified in the claim or notice. If an incident involves more than one such code, each shall be reported separately in the report. If the production year of the child restraint system is unknown, the manufacturer shall specify the number “9999” in the field for production year.

(c) *Numbers of consumer complaints and warranty claims, and field reports.* Separate reports on the numbers of those consumer complaints and warranty claims, and field reports, which involve the systems and components that are specified in codes 51 through 54 in paragraph (b)(2) of this section. Each such report shall state, separately by each such code, the number of such consumer complaints and warranty claims, or field reports, respectively, that involves the systems or components indicated by the code. If an underlying consumer complaint and

warranty claim, or field report, involves more than one such code, each shall be counted separately in the report with no limit on the number of codes to be included. No reporting is necessary if the system or component involved is not specified in such codes.

(d) *Copies of field reports.* For all child restraint systems manufactured during a production year covered by the reporting period and the four production years prior to the earliest production year in the reporting period, a copy of each field report (other than a dealer report or a product evaluation report) involving one or more of the systems or components identified in paragraph (b)(2) of this section, containing any assessment of an alleged failure, malfunction, lack of durability, or other performance problem of a child restraint system (including any part thereof) that is originated by an employee or representative of the manufacturer and that the manufacturer received during a reporting period. These documents shall be submitted alphabetically by make, within each make alphabetically by model, and within each model chronologically by production year. For purposes of this paragraph, if a field report refers to more than one make or model of child restraint system produced by a manufacturer, the manufacturer shall submit the report under the first such model in alphabetical order. If a field report refers to more than one production year of a specified make/model, the manufacturer shall submit it by the earliest production year to which it refers.

[67 FR 45873, July 10, 2002, as amended at 68 FR 18143, Apr. 15, 2003; 68 FR 35144, June 11, 2003; 72 FR 29444, May 29, 2007]

§ 579.26 Reporting requirements for manufacturers of tires.

For each reporting period, a manufacturer (including a brand name owner) who has manufactured for sale, sold, offered for sale, introduced or delivered for introduction in interstate commerce, or imported tires in the United States shall submit the information described in this section. For purposes of this section, an importer of motor vehicles for resale is deemed to be the manufacturer of the tires on and

in the vehicle at the time of its importation if the manufacturer of the tires is not required to report under this section. For paragraphs (a) and (c) of this section, the manufacturer shall submit information separately with respect to each tire line, size, SKU, plant where manufactured, and model year of tire manufactured during the reporting period and the four calendar years prior to the reporting period, including tire lines no longer in production. For each group of tires with the same SKU, plant where manufactured, and year for which the volume produced or imported is less than 15,000, or are deep tread, winter-type snow tires, space-saver or temporary use spare tires, tires with nominal rim diameters of 12 inches or less, or are not passenger car tires, light truck tires, or motorcycle tires, the manufacturer need only report information on incidents involving a death or injury, as specified in paragraph (b) of this section. For purposes of this section, the two-character DOT alphanumeric code for production plants located in the United States assigned by NHTSA in accordance with §§ 574.5(a) and 574.6(b) of this chapter may be used to identify "plant where manufactured." If the production plant is located outside the United States, the full plant name must be provided.

(a) *Production information.* Information that states the manufacturer's name, the quarterly reporting period, the tire line, the tire size, the tire type code, the SKU, the plant where manufactured, whether the tire is approved for use as original equipment on a motor vehicle, if so, the make, model, and model year of each vehicle for which it is approved, the production year, the cumulative warranty production, and the cumulative total production through the end of the reporting period. If the manufacturer knows that a particular group of tires is not used as original equipment on a motor vehicle, it shall state "N" in the appropriate field, and if the manufacturer is not certain, it shall state "U" in that field.

(b) *Information on incidents involving death or injury.* For all tires manufactured during a production year covered by the reporting period and the four production years prior to the earliest

§579.27

49 CFR Ch. V (10–1–10 Edition)

production year in the reporting period:

(1) A report on each incident involving one or more deaths or injuries occurring in the United States that is identified in a claim against and received by the manufacturer or in a notice received by the manufacturer which notice alleges or proves that the death or injury was caused by a possible defect in the manufacturer's tire, together with each incident involving one or more deaths occurring in a foreign country that is identified in a claim against and received by the manufacturer involving the manufacturer's tire, if that tire is identical or substantially similar to a tire that the manufacturer has offered for sale in the United States. The report shall be submitted as a report on tires and organized such that incidents are reported alphabetically by tire line, within each tire line by tire size, and within each tire size chronologically by production year.

(2) For each such incident described in paragraph (b)(1) of this section, the manufacturer shall separately report the tire line, size, and production year of the tire, the TIN, the incident date, the number of deaths, the number of injuries for incidents occurring in the United States, the State or foreign country where the incident occurred, the make, model, and model year of the vehicle on which the tire was installed, and each component of the tire that allegedly contributed to the incident, coded as follows: 71 tread, 72 sidewall, 73 bead, 98 where a component not covered by categories 71 through 73 is specified in the claim or notice, and 99 where no component of the tire is specified in the claim or notice. If an incident involves more than one such code, each shall be reported separately in the report.

(c) *Numbers of property damage claims and warranty adjustments.* Separate reports on the numbers of those property damage claims and warranty adjustments which involve the components that are specified in codes 71 through 73, and 98, in paragraph (b)(2) of this section. Each such report shall state, separately by each such code, the numbers of such property damage claims and warranty adjustments, respec-

tively, that involve the components indicated by the code. If an underlying property damage claim or warranty adjustment involves more than one such code, each shall be reported separately in the report with no limit on the number of codes to be included. No reporting is necessary if the system or component involved is not specified in such codes, or if the TIN is not specified in any property damage claim.

(d) *Common green tire reporting.* With each quarterly report, each manufacturer of tires shall provide NHTSA with a list of common green tires. For each specific common green tire grouping, the list shall provide all relevant tire lines, tire type codes, SKU numbers, brand names, and brand name owners.

[67 FR 45873, July 10, 2002, as amended at 68 FR 18143, Apr. 15, 2003; 68 FR 35144, June 11, 2003]

§579.27 Reporting requirements for manufacturers of fewer than 100 buses annually, for manufacturers of fewer than 500 emergency vehicles annually, for manufacturers of fewer than 5,000 light vehicles, medium-heavy vehicles (other than buses and emergency vehicles), motorcycles or trailers annually, for manufacturers of original equipment, and for manufacturers of replacement equipment other than child restraint systems and tires.

(a) *Applicability.* This section applies to all manufacturers of vehicles with respect to vehicles that are not covered by reports on light vehicles, medium-heavy vehicles and buses, motorcycles, or trailers submitted pursuant to §§579.21 through 579.24 of this part, to all manufacturers of original equipment, to all manufacturers of replacement equipment other than manufacturers of tires and child restraint systems, and to registered importers registered under 49 U.S.C. 30141(c).

(b) *Information on incidents involving deaths.* For each reporting period, a manufacturer to which this section applies shall submit a report, pertaining to vehicles and/or equipment manufactured or sold during the calendar year of the reporting period and the nine calendar years prior to the reporting period (four calendar years for equipment), including models no longer in

production, on each incident involving one or more deaths occurring in the United States that is identified in a claim against and received by the manufacturer or in a notice received by the manufacturer which alleges or proves that the death was caused by a possible defect in the manufacturer's vehicle or equipment, together with each incident involving one or more deaths occurring in a foreign country that is identified in a claim against and received by the manufacturer involving the manufacturer's vehicle or equipment, if it is identical or substantially similar to a vehicle or item of equipment that the manufacturer has offered for sale in the United States. The report shall be organized such that incidents are reported alphabetically by make, within each make alphabetically by model, and within each model chronologically by model year. If a manufacturer has not received such a claim or notice during a reporting period, the manufacturer need not submit a report to NHTSA for that reporting period.

(c) For each incident described in paragraph (b) of this section, the manufacturer shall separately report the make, model, and model year of the vehicle or equipment, the VIN (for vehicles only), the incident date, the number of deaths, the number of injuries for incidents occurring in the United States, the State or foreign country where the incident occurred, each system or component of the vehicle or equipment that allegedly contributed to the incident, and whether the incident involved a fire or rollover, as follows:

(1) For light vehicles, the system or component involved, and the existence of a fire or rollover, shall be identified and coded as specified in § 579.21(b)(2) of this part.

(2) For medium-heavy vehicles and buses, the system or component involved, and the existence of a fire or rollover, shall be identified and coded as specified in § 579.22(b)(2) of this part.

(3) For motorcycles, the system or component involved, and the existence of a fire, shall be identified and coded as specified in § 579.23(b)(2) of this part.

(4) For trailers, the system or component involved, and the existence of a

fire, shall be identified and coded as specified in § 579.24(b)(2) of this part.

(5) For original and replacement equipment, a written identification of each component of the equipment that was allegedly involved, and whether there was a fire, in the manufacturer's own words.

(6) For original and replacement equipment, if the production year of the equipment is unknown, the manufacturer shall specify the number "9999" in the field for model or production year.

[67 FR 45873, July 10, 2002, as amended at 68 FR 18143, Apr. 15, 2003; 68 FR 35144, June 11, 2003; 74 FR 47758, Sept. 17, 2009]

§ 579.28 Due date of reports and other miscellaneous provisions.

(a) *Initial submission of reports.* Except as provided in paragraph (n) of this section, the first calendar quarter for which reports are required under §§ 579.21 through 579.27 of this subpart is the third calendar quarter of 2003.

(b) *Due date of reports.* Except as provided in subsection (n) of this section, each manufacturer of motor vehicles and motor vehicle equipment shall submit each report that is required by this subpart not later than 60 days after the last day of the reporting period. Except as provided in § 579.27(b), if a manufacturer has not received any of the categories of information or documents during a quarter for which it is required to report pursuant to §§ 579.21 through 579.26, the manufacturer's report must indicate that no relevant information or documents were received during that quarter. If the due date for any report is a Saturday, Sunday or a Federal holiday, the report shall be due on the next business day.

(c) One-time reporting of historical information. (1) No later than January 15, 2004:

(i) Each manufacturer of vehicles covered by §§ 579.21 through 579.24 of this part shall file separate reports providing information on the numbers of warranty claims recorded in the manufacturer's warranty system, and field reports, that it received in each calendar quarter from July 1, 2000, to June 30, 2003, for vehicles manufactured in

§ 579.28

model years 1994 through 2003 (including any vehicle designated as a 2004 model);

(ii) Each manufacturer of child restraint systems covered by § 579.25 of this part shall file separate reports covering the numbers of warranty claims recorded in the manufacturer's warranty system and consumer complaints (added together), and field reports, that it received in each calendar quarter from July 1, 2000, to June 30, 2003, for child restraint systems manufactured from July 1, 1998, to June 30, 2003, and

(iii) Each manufacturer of tires covered by § 579.26 of this part shall file separate reports covering the numbers of warranty adjustments recorded in the manufacturer's warranty adjustment system for tires that it received in each calendar quarter from July 1, 2000, to June 30, 2003, for tires manufactured from July 1, 1998, to June 30, 2003.

(2) Each report filed under paragraph (c)(1) of this section shall include production data, as specified in paragraph (a) of 579.21 through 579.26 of this part and shall identify the alleged system or component covered by warranty claim, warranty adjustment, or field report as specified in paragraph (c) of 579.21 through 579.26 of this part.

(d) *Minimal specificity.* A claim or notice involving death, a claim or notice involving injury, a claim involving property damage, a consumer complaint, a warranty claim or warranty adjustment, or a field report need not be reported if it does not identify the vehicle or equipment with minimal specificity. If a manufacturer initially receives a claim, notice, complaint, warranty claim, warranty adjustment, or field report in which the vehicle or equipment is not identified with minimal specificity and subsequently obtains information that provides the requisite information needed to identify the product with minimal specificity, the claim, etc. shall be deemed to have been received when the additional information is received. If a manufacturer receives a claim or notice involving death or injury in which the vehicle or equipment is not identified with minimal specificity and the matter is being handled by legal counsel retained by the manufacturer, the

49 CFR Ch. V (10–1–10 Edition)

manufacturer shall attempt to obtain the missing minimal specificity information from such counsel.

(e) *Claims received by registered agents.* A claim received by any registered agent of a manufacturer under the laws of any State, or the agent that any manufacturer offering motor vehicles or motor vehicle equipment for import has designated pursuant to 49 U.S.C. 30164(a), shall be deemed received by the manufacturer.

(f) *Updating of information required in reports.* (1) Except as specified in this subsection, a manufacturer need not update its reports under this subpart.

(2) With respect to each report of an incident submitted under paragraph (b) of §§ 579.21 through 579.26 of this part:

(i) If a vehicle manufacturer is not aware of the VIN, or a tire manufacturer is not aware of the TIN, at the time the incident is initially reported, the manufacturer shall submit an updated report of such incident in its report covering the reporting period in which the VIN or TIN is identified. A manufacturer need not submit an updated report if the VIN or TIN is identified by the manufacturer in a reporting period that is more than one year later than the initial report to NHTSA.

(ii) If a manufacturer indicated code 99 in its report because a system or component had not been identified in the claim or notice that led to the report, and the manufacturer becomes aware during a subsequent calendar quarter that one or more of the specified systems or components allegedly contributed to the incident, the manufacturer shall submit an updated report of such incident in its report covering the reporting period in which the involved specified system(s) or component(s) is (are) identified. A manufacturer need not submit an updated report if the system(s) or component(s) is(are) identified by the manufacturer in a reporting period that is more than one year later than the initial report to NHTSA.

(iii) If one or more systems or components is identified in a manufacturer's report of an incident, the manufacturer need not submit an updated report to

reflect additional systems or components allegedly involved in the incident that it becomes aware of in a subsequent reporting period.

(iv) If the report is of an incident involving an injury and an injured person dies after a manufacturer has reported the injury to NHTSA, the manufacturer need not submit an updated report to NHTSA reflecting that death.

(g) *When a report involving a death is not required.* A report on incident(s) involving one or more deaths occurring in a foreign country that is identified in claim(s) against a manufacturer of motor vehicles or motor vehicle equipment involving a vehicle or equipment that is identical or substantially similar to equipment that the manufacturer has offered for sale in the United States need not be furnished if the claim specifically alleges that the death was caused by a possible defect in a component other than one that is common to the vehicle or equipment that the manufacturer has offered for sale in the United States.

(h) *When a report involving a claim or notice is not required.* If a manufacturer has reported a claim or notice relating to an incident involving death or injury, the manufacturer need not:

(1) Report a claim or notice arising out of the incident by a person who was not injured physically, and

(2) Include in its number of property damage claims a property damage claim arising out of the incident.

(i) *Reporting on behalf of other manufacturers.* Whenever a fabricating manufacturer or importer submits a report on behalf of one or more other manufacturers (including a brand name owner), as authorized under § 579.3(b) of this part, the submitting manufacturer must identify each such other manufacturer. Whenever a brand name owner submits a report on its own behalf, it must identify the fabricating manufacturer of each separate product on which it is reporting.

(j) *Abbreviations.* Whenever a manufacturer is required to identify a State in which an incident occurred, the manufacturer shall use the two-letter abbreviations established by the United States Postal Service (e.g., AZ for Arizona). Whenever a manufacturer is required to identify a foreign coun-

try in which an incident occurred, the manufacturer shall use the English-language name of the country in non-abbreviated form.

(k) *Claims of confidentiality.* If a manufacturer claims that any of the information, data, or documents that it submits is entitled to confidential treatment, it must make such claim in accordance with part 512 of this chapter.

(l) *Additional related information that NHTSA may request.* In addition to information required periodically under this subpart, NHTSA may request other information that may help identify a defect related to motor vehicle safety.

(m) *Use of the plural.* As used in this part, the plural includes the singular and the singular includes the plural to bring within the scope of reporting that which might otherwise be construed to be without the scope.

(n) *Submission of copies of field reports.* Copies of field reports required under this subpart shall be submitted not later than 15 days after reports are due pursuant to paragraph (b) of this section.

[67 FR 45873, July 10, 2002, as amended at 68 FR 18143, Apr. 15, 2003; 68 FR 20225, Apr. 24, 2003; 68 FR 35144, 35148, June 11, 2003; 68 FR 64569, Nov. 14, 2003; 69 FR 57869, Sept. 28, 2004; 70 FR 2023, Jan. 12, 2005; 72 FR 29444, May 29, 2007]

§ 579.29 Manner of reporting.

(a) *Submission of reports.* (1) Except as provided in this paragraph, each report required under paragraphs (a) through (c) of §§ 579.21 through 579.26 of this part must be submitted to NHTSA's early warning data repository identified on NHTSA's Internet homepage (www.nhtsa.dot.gov). A manufacturer must use templates provided at the early warning website, also identified on NHTSA's homepage, for submitting reports. For data files smaller than the size limit of the Internet e-mail server of the Department of Transportation, a manufacturer may submit a report as an attachment to an e-mail message to odi.eur@nhtsa.dot.gov, using the same templates.

(2) Each report required under § 579.27 of this part may be submitted to NHTSA's early warning data repository as specified in paragraph (a)(1) of

this section or by manually filling out an interactive form on NHTSA's early warning website.

(3) For each report required under paragraphs (a) through (c) of §§ 579.21 through 579.26 of this part and submitted in the manner provided in paragraph (a)(1) of this section, a manufacturer must state the make, model and model year of each motor vehicle or item of motor vehicle equipment in terms that are identical to the statement of the make, model, model year of each motor vehicle or item of motor vehicle equipment provided in the manufacturer's previous report.

(b) *Submission of documents.* A copy of each document required under paragraph (d) of §§ 579.21 through 579.26 of this part may be submitted in digital form using a graphic compression protocol, approved by NHTSA, to the NHTSA data repository, or as an attachment to an e-mail message, as specified in paragraph (a)(1) of this section. Any digital image provided by a manufacturer shall be not less than 200 or more than 300 dpi (dots per inch) resolution. Such documents may also be submitted in paper form. Each document shall be identified in accordance with the templates provided at NHTSA's early warning Web site, which is identified in paragraph (a)(1) of this section.

(c) *Designation of manufacturer contacts.* Not later than 30 days prior to the date of its first quarterly submission, each manufacturer must provide the names, office telephone numbers, postal and street mailing addresses, and electronic mail addresses of two employees (one primary and one backup) whom NHTSA may contact for resolving issues that may arise concerning the submission of information and documents required by this part.

(d) *Manufacturer reporting identification and password.* Not later than 30 days prior to the date of its first quarterly submission, each manufacturer must request a manufacturer identification number and a password.

(e) *Graphic compression protocol.* Not later than 30 days prior to the date of its first quarterly submission, each manufacturer which wishes to submit a copy of a document in digital form, as provided in paragraph (b) of this sec-

tion, must obtain approval from NHTSA for the use of such protocol.

(f) Information and requests submitted under paragraphs (c), (d), and (e) of this section shall be provided in writing to the Director, Office of Defects Investigation, NHTSA, Attention: Early Warning Division (NVS-217), 1200 New Jersey Avenue, SE., Washington, DC 20590.

[67 FR 45873, July 10, 2002, as amended at 68 FR 35145, June 11, 2003; 72 FR 32017, June 11, 2007; 74 FR 47758, Sept. 17, 2009]

PART 580—ODOMETER DISCLOSURE REQUIREMENTS

Sec.

- 580.1 Scope.
- 580.2 Purpose.
- 580.3 Definitions.
- 580.4 Security of title documents and power of attorney forms.
- 580.5 Disclosure of odometer information.
- 580.6 [Reserved]
- 580.7 Disclosure of odometer information for leased motor vehicles.
- 580.8 Odometer disclosure statement retention.
- 580.9 Odometer record retention for auction companies.
- 580.10 Application for assistance.
- 580.11 Petition for approval of alternate disclosure requirements.
- 580.12 Petition for extension of time.
- 580.13 Disclosure of odometer information by power of attorney.
- 580.14 Power of attorney to review title documents and acknowledge disclosure.
- 580.15 Certification by person exercising powers of attorney.
- 580.16 Access of transferee to prior title and power of attorney documents.
- 580.17 Exemptions.

APPENDIX A TO PART 580—SECURE PRINTING PROCESSES AND OTHER SECURE PROCESSES

APPENDIX B TO PART 580—DISCLOSURE FORM FOR TITLE

APPENDIX C TO PART 580—SEPARATE DISCLOSURE FORM

APPENDIX D TO PART 580—DISCLOSURE FORM FOR LEASED VEHICLE

APPENDIX E TO PART 580—POWER OF ATTORNEY DISCLOSURE FORM

AUTHORITY: 49 U.S.C. 32705; delegation of authority at 49 CFR 1.50(f) and 501.8(e)(1).

SOURCE: 53 FR 29476, Aug. 5, 1988, unless otherwise noted.

§ 580.1 Scope.

This part prescribes rules requiring transferors and lessees of motor vehicles to make written disclosure to transferees and lessors respectively, concerning the odometer mileage and its accuracy as directed by sections 408 (a) and (e) of the Motor Vehicle Information and Cost Savings Act as amended, 15 U.S.C. 1988 (a) and (e). In addition, this part prescribes the rules requiring the retention of odometer disclosure statements by motor vehicle dealers, distributors and lessors and the retention of certain other information by auction companies as directed by sections 408(g) and 414 of the Motor Vehicle Information and Cost Savings Act as amended, 15 U.S.C. 1990(d) and 1988(g).

§ 580.2 Purpose.

The purpose of this part is to provide purchasers of motor vehicles with odometer information to assist them in determining a vehicle's condition and value by making the disclosure of a vehicle's mileage a condition of title and by requiring lessees to disclose to their lessors the vehicle's mileage at the time the lessors transfer the vehicle. In addition, the purpose of this part is to preserve records that are needed for the proper investigation of possible violations of the Motor Vehicle Information and Cost Savings Act and any subsequent prosecutorial, adjudicative or other action.

§ 580.3 Definitions.

All terms defined in sections 2 and 402 of the Motor Vehicle Information and Cost Savings Act are used in their statutory meaning. Other terms used in this part are defined as follows:

Lessee means any person, or the agent for any person, to whom a motor vehicle has been leased for a term of at least 4 months.

Lessor means any person, or the agent for any person, who has leased 5 or more motor vehicles in the past 12 months.

Mileage means actual distance that a vehicle has traveled.

Original power of attorney means, for single copy forms, the document set forth by secure process which is issued by the State, and, for multicopy forms,

any and all copies set forth by secure process which are issued by the State.

Secure printing process or other secure process means any process which deters and detects counterfeiting and/or unauthorized reproduction and allows alterations to be visible to the naked eye.

Transferee means any person to whom ownership of a motor vehicle is transferred, by purchase, gift, or any means other than by the creation of a security interest, and any person who, as agent, signs an odometer disclosure statement for the transferee.

Transferor means any person who transfers his ownership of a motor vehicle by sale, gift, or any means other than by the creation of a security interest, and any person who, as agent, signs an odometer disclosure statement for the transferor.

[53 FR 29476, Aug. 5, 1988, as amended at 54 FR 35887, Aug. 30, 1989; 56 FR 47686, Sept. 20, 1991]

§ 580.4 Security of title documents and power of attorney forms.

Each title shall be set forth by means of a secure printing process or other secure process. In addition, power of attorney forms issued pursuant to §§ 580.13 and 580.14 and documents which are used to reassign the title shall be issued by the State and shall be set forth by a secure process.

[54 FR 35887, Aug. 30, 1989]

§ 580.5 Disclosure of odometer information.

(a) Each title, at the time it is issued to the transferee, must contain the mileage disclosed by the transferor when ownership of the vehicle was transferred and contain a space for the information required to be disclosed under paragraphs (c), (d), (e) and (f) of this section at the time of future transfer.

(b) Any documents which are used to reassign a title shall contain a space for the information required to be disclosed under paragraphs (c), (d), (e) and (f) of this section at the time of transfer of ownership.

(c) In connection with the transfer of ownership of a motor vehicle, each transferor shall disclose the mileage to the transferee in writing on the title

§ 580.6

or, except as noted below, on the document being used to reassign the title. In the case of a transferor in whose name the vehicle is titled, the transferor shall disclose the mileage on the title, and not on a reassignment document. This written disclosure must be signed by the transferor, including the printed name. In connection with the transfer of ownership of a motor vehicle in which more than one person is a transferor, only one transferor need sign the written disclosure. In addition to the signature and printed name of the transferor, the written disclosure must contain the following information:

(1) The odometer reading at the time of transfer (not to include tenths of miles);

(2) The date of transfer;

(3) The transferor's name and current address;

(4) The transferee's name and current address; and

(5) The identity of the vehicle, including its make, model, year, and body type, and its vehicle identification number.

(d) In addition to the information provided under paragraph (c) of this section, the statement shall refer to the Federal law and shall state that failure to complete or providing false information may result in fines and/or imprisonment. Reference may also be made to applicable State law.

(e) In addition to the information provided under paragraphs (c) and (d) of this section,

(1) The transferor shall certify that to the best of his knowledge the odometer reading reflects the actual mileage, or;

(2) If the transferor knows that the odometer reading reflects the amount of mileage in excess of the designed mechanical odometer limit, he shall include a statement to that effect; or

(3) If the transferor knows that the odometer reading differs from the mileage and that the difference is greater than that caused by odometer calibration error, he shall include a statement that the odometer reading does not reflect the actual mileage, and should not be relied upon. This statement shall also include a warning notice to alert the transferee that a discrepancy

49 CFR Ch. V (10-1-10 Edition)

exists between the odometer reading and the actual mileage.

(f) The transferee shall sign the disclosure statement, print his name, and return a copy to his transferor.

(g) If the vehicle has not been titled or if the title does not contain a space for the information required, the written disclosure shall be executed as a separate document.

(h) No person shall sign an odometer disclosure statement as both the transferor and transferee in the same transaction, unless permitted by §§ 580.13 or 580.14.

[53 FR 29476, Aug. 5, 1988, as amended at 54 FR 35887, Aug. 30, 1989; 56 FR 47686, Sept. 20, 1991]

§ 580.6 [Reserved]

§ 580.7 Disclosure of odometer information for leased motor vehicles.

(a) Before executing any transfer of ownership document, each lessor of a leased motor vehicle shall notify the lessee in writing that the lessee is required to provide a written disclosure to the lessor regarding the mileage. This notice shall contain a reference to the federal law and shall state that failure to complete or providing false information may result in fines and/or imprisonment. Reference may also be made to applicable State law.

(b) In connection with the transfer of ownership of the leased motor vehicle, the lessee shall furnish to the lessor a written statement regarding the mileage of the vehicle. This statement must be signed by the lessee and, in addition to the information required by paragraph (a) of this section, shall contain the following information:

(1) The printed name of the person making the disclosure;

(2) The current odometer reading (not to include tenths of miles);

(3) The date of the statement;

(4) The lessee's name and current address;

(5) The lessor's name and current address;

(6) The identity of the vehicle, including its make, model, year, and body type, and its vehicle identification number;

(7) The date that the lessor notified the lessee of disclosure requirements;

(8) The date that the completed disclosure statement was received by the lessor; and

(9) The signature of the lessor.

(c) In addition to the information provided under paragraphs (a) and (b) of this section,

(1) The lessee shall certify that to the best of his knowledge the odometer reading reflects the actual mileage; or

(2) If the lessee knows that the odometer reading reflects the amount of mileage in excess of the designed mechanical odometer limit, he shall include a statement to that effect; or

(3) If the lessee knows that the odometer reading differs from the mileage and that the difference is greater than that caused by odometer calibration error, he shall include a statement that the odometer reading is not the actual mileage and should not be relied upon.

(d) If the lessor transfers the leased vehicle without obtaining possession of it, the lessor may indicate on the title the mileage disclosed by the lessee under paragraph (b) and (c) of this section, unless the lessor has reason to believe that the disclosure by the lessee does not reflect the actual mileage of the vehicle.

§ 580.8 Odometer disclosure statement retention.

(a) Dealers and distributors of motor vehicles who are required by this part to execute an odometer disclosure statement shall retain for five years a photostat, carbon or other facsimile copy of each odometer mileage statement which they issue and receive. They shall retain all odometer disclosure statements at their primary place of business in an order that is appropriate to business requirements and that permits systematic retrieval.

(b) Lessors shall retain, for five years following the date they transfer ownership of the leased vehicle, each odometer disclosure statement which they receive from a lessee. They shall retain all odometer disclosure statements at their primary place of business in an order that is appropriate to business requirements and that permits systematic retrieval.

(c) Dealers and distributors of motor vehicles who are granted a power of attorney by their transferor pursuant to

§ 580.13, or by their transferee pursuant to § 580.14, shall retain for five years a photostat, carbon, or other facsimile copy of each power of attorney that they receive. They shall retain all powers of attorney at their primary place of business in an order that is appropriate to business requirements and that permits systematic retrieval.

[53 FR 29476, Aug. 5, 1988, as amended at 54 FR 35888, Aug. 30, 1989]

§ 580.9 Odometer record retention for auction companies.

Each auction company shall establish and retain at its primary place of business in an order that is appropriate to business requirements and that permits systematic retrieval, for five years following the date of sale of each motor vehicle, the following records:

(a) The name of the most recent owner (other than the auction company);

(b) The name of the buyer;

(c) The vehicle identification number; and

(d) The odometer reading on the date which the auction company took possession of the motor vehicle.

§ 580.10 Application for assistance.

(a) A State may apply to NHTSA for assistance in revising its laws to comply with the requirements of 408(d) (1) and (2) of the Motor Vehicle Information and Cost Savings Act, 15 U.S.C. 1988(d) (1) and (2) and §§ 580.4 and 580.5 of this part.

(b) Each application filed under section shall—

(1) Be written in the English language;

(2) Be submitted, to the Office of Chief Counsel, National Highway Traffic Safety Administration, 400 Seventh Street, SW., Washington, DC 20590;

(3) Include a copy of current motor vehicle titling and/or disclosure requirements in effect in the State; and

(4) Include a draft of legislation or regulations intended to amend or revise current State motor vehicle titling and/or disclosure requirements to conform with Federal requirements.

(c) The agency will respond to the applicant, in writing, and provide a list of the Federal statutory and/or regulatory requirements that the State

§ 580.11

may have failed to include in its proposal and indicate if any sections of the proposal appear to conflict with Federal requirements.

§ 580.11 Petition for approval of alternate disclosure requirements.

(a) A State may petition NHTSA for approval of disclosure requirements which differ from the disclosure requirements of § 580.5, § 580.7, or § 580.13(f) of this part.

(b) Each petition filed under this section shall—

(1) Be written in the English language;

(2) Be submitted to the Office of Chief Counsel, National Highway Traffic Safety Administration, 400 Seventh Street SW., Washington, DC 20590;

(3) Set forth the motor vehicle disclosure requirements in effect in the State, including a copy of the applicable State law or regulation; and

(4) Explain how the State motor vehicle disclosure requirements are consistent with the purposes of the Motor Vehicle Information and Cost Savings Act.

(c) Notice of the petition and an initial determination pending a 30-day comment period will be published in the FEDERAL REGISTER. Notice of final grant or denial of a petition for approval of alternate motor vehicle disclosure requirements will be published in the FEDERAL REGISTER. The effect of the grant of a petition is to relieve a State from responsibility to conform the State disclosure requirements with § 580.5, § 580.7, or § 580.13(f), as applicable, for as long as the approved alternate disclosure requirements remain in effect in that State. The effect of a denial is to require a State to conform to the requirements of § 580.5, § 580.7 or § 580.13(f), as applicable, of this part until such time as the NHTSA approves any alternate motor vehicle disclosure requirements.

[53 FR 29476, Aug. 5, 1988, as amended at 56 FR 47686, Sept. 20, 1991]

§ 580.12 Petition for extension of time.

(a) If a State cannot conform its laws to achieve compliance with this part by April 29, 1989, the State may petition for an extension of time.

49 CFR Ch. V (10–1–10 Edition)

(b) Each petition filed under this section shall—

(1) Be written in the English language;

(2) Be submitted, by February 28, 1989, to the Office of Chief Counsel, National Highway Traffic Safety Administration, 400 Seventh Street SW., Washington, DC, 20590;

(3) Set forth a chronological analysis of the efforts the State has taken to meet the deadline, the reasons why it did not do so, the length of time desired for extension and a description of the steps to be taken while the extension is in effect.

(c) Notice of either the grant or denial of the petition is issued to the petitioner and will be published in the FEDERAL REGISTER.

(d) A petition for a renewal of an extension of time must be filed no later than 30 days prior to the termination of the extension of time granted by the Agency. A petition for a renewal of an extension of time must meet the same requirements as the original petition for an extension of time.

(e) If a petition for a renewal of the extension of time which meets the requirements of § 580.12(b) is filed, the extension of time will continue until a decision is made on the renewal petition.

§ 580.13 Disclosure of odometer information by power of attorney.

(a) If the transferor's title is physically held by a lienholder, or if the transferor to whom the title was issued by the State has lost his title and the transferee obtains a duplicate title on behalf of the transferor, and if otherwise permitted by State law, the transferor may give a power of attorney to his transferee for the purpose of mileage disclosure. The power of attorney shall be on a form issued by the State to the transferee that is set forth by means of a secure printing process or other secure process, and shall contain, in part A, a space for the information required to be disclosed under paragraphs (b), (c), (d), and (e) of this section. If a State permits the use of a power of attorney in the situation described in § 580.14(a), the form must also contain, in part B, a space for the information required to be disclosed

under § 580.14, and, in part C, a space for the certification required to be made under § 580.15.

(b) In connection with the transfer of ownership of a motor vehicle, each transferor to whom a title was issued by the State whose title is physically held by a lienholder or whose title has been lost, and who elects to give his transferee a power of attorney for the purpose of mileage disclosure, must appoint the transferee his attorney-in-fact for the purpose of mileage disclosure and disclose the mileage on the power of attorney form issued by the State. This written disclosure must be signed by the transferor, including the printed name, and contain the following information:

(1) The odometer reading at the time of transfer (not to include tenths of miles);

(2) The date of transfer;

(3) The transferor's name and current address;

(4) The transferee's name and current address; and

(5) The identity of the vehicle, including its make, model year, body type and vehicle identification number.

(c) In addition to the information provided under paragraph (b) of this section, the power of attorney form shall refer to the Federal odometer law and state that providing false information or the failure of the person granted the power of attorney to submit the form to the State may result in fines and/or imprisonment. Reference may also be made to applicable State law.

(d) In addition to the information provided under paragraphs (b) and (c) of this section:

(1) The transferor shall certify that to the best of his knowledge the odometer reading reflects the actual mileage; or

(2) If the transferor knows that the odometer reading reflects mileage in excess of the designed mechanical odometer limit, he shall include a statement to that effect; or

(3) If the transferor knows that the odometer reading differs from the mileage and the difference is greater than that caused by a calibration error, he shall include a statement that the odometer reading does not reflect the actual mileage and should not be relied

upon. This statement shall also include a warning notice to alert the transferee that a discrepancy exists between the odometer reading and the actual mileage.

(e) The transferee shall sign the power of attorney form, print his name, and return a copy of the power of attorney form to the transferor.

(f) Upon receipt of the transferor's title, the transferee shall complete the space for mileage disclosure on the title exactly as the mileage was disclosed by the transferor on the power of attorney form. The transferee shall submit the original power of attorney form to the State that issued it, with a copy of the transferor's title or with the actual title when the transferee submits a new title application at the same time. The State shall retain the power of attorney form and title for three years or a period equal to the State titling record retention period, whichever is shorter. If the mileage disclosed on the power of attorney form is lower than the mileage appearing on the title, the power of attorney is void and the dealer shall not complete the mileage disclosure on the title.

[54 FR 35888, Aug. 30, 1989, as amended at 54 FR 40083, Sept. 29, 1989; 56 FR 47686, Sept. 20, 1991]

§ 580.14 Power of attorney to review title documents and acknowledge disclosure.

(a) In circumstances where part A of a secure power of attorney form has been used pursuant to § 580.13 of this part, and if otherwise permitted by State law, a transferee may give a power of attorney to his transferor to review the title and any reassignment documents for mileage discrepancies, and if no discrepancies are found, to acknowledge disclosure on the title. The power of attorney shall be on part B of the form referred to in § 580.13(a), which shall contain a space for the information required to be disclosed under paragraphs (b), (c), (d), and (e) of this section and, in part C, a space for the certification required to be made under § 580.15.

(b) The power of attorney must include a mileage disclosure from the transferor to the transferee and must

§ 580.15

be signed by the transferor, including the printed name, and contain the following information:

(1) The odometer reading at the time of transfer (not to include tenths of miles);

(2) The date of transfer;

(3) The transferor's name and current address;

(4) The transferee's name and current address; and

(5) The identity of the vehicle, including its make, model year, body type and vehicle identification number.

(c) In addition to the information provided under paragraph (b) of this section, the power of attorney form shall refer to the Federal odometer law and state that providing false information or the failure of the person granted the power of attorney to submit the form to the State may result in fines and/or imprisonment. Reference may also be made to applicable State law.

(d) In addition to the information provided under paragraphs (b) and (c) of this section:

(1) The transferor shall certify that to the best of his knowledge the odometer reading reflects the actual mileage;

(2) If the transferor knows that the odometer reading reflects mileage in excess of the designed mechanical odometer limit, he shall include a statement to that effect; or

(3) If the transferor knows that the odometer reading differs from the mileage and the difference is greater than that caused by a calibration error, he shall include a statement that the odometer reading does not reflect the actual mileage and should not be relied upon. This statement shall also include a warning notice to alert the transferee that a discrepancy exists between the odometer reading and the actual mileage.

(e) The transferee shall sign the power of attorney form, and print his name.

(f) The transferor shall give a copy of the power of attorney form to his transferee.

[54 FR 35888, Aug. 30, 1989]

49 CFR Ch. V (10-1-10 Edition)

§ 580.15 Certification by person exercising powers of attorney.

(a) A person who exercises a power of attorney under both §§ 580.13 and 580.14 must complete a certification that he has disclosed on the title document the mileage as it was provided to him on the power of attorney form, and that upon examination of the title and any reassignment documents, the mileage disclosure he has made on the title pursuant to the power of attorney is greater than that previously stated on the title and reassignment documents. This certification shall be under part C of the same form as the powers of attorney executed under §§ 580.13 and 580.14 and shall include:

(1) The signature and printed name of the person exercising the power of attorney;

(2) The address of the person exercising the power of attorney; and

(3) The date of the certification.

(b) If the mileage reflected by the transferor on the power of attorney is less than that previously stated on the title and any reassignment documents, the power of attorney shall be void.

[54 FR 35889, Aug. 30, 1989]

§ 580.16 Access of transferee to prior title and power of attorney documents.

(a) In circumstances in which a power of attorney has been used pursuant to § 580.13 of this part, if a subsequent transferee elects to return to his transferor to sign the disclosure on the title when the transferor obtains the title and does not give his transferor a power of attorney to review the title and reassignment documents, upon the transferee's request, the transferor shall show to the transferee a copy of the power of attorney that he received from his transferor.

(b) Upon request of a purchaser, a transferor who was granted a power of attorney by his transferor and who holds the title to the vehicle in his own name, must show to the purchaser the copy of the previous owner's title and the power of attorney form.

[54 FR 35889, Aug. 30, 1989]

§ 580.17 Exemptions.

Notwithstanding the requirements of §§ 580.5 and 580.7:

(a) A transferor or a lessee of any of the following motor vehicles need not disclose the vehicle's odometer mileage:

- (1) A vehicle having a Gross Vehicle Weight Rating, as defined in §571.3 of this title, of more than 16,000 pounds;
(2) A vehicle that is not self-propelled;
(3) A vehicle that was manufactured in a model year beginning at least ten years before January 1 of the calendar year in which the transfer occurs; or

Example to paragraph (a)(3): For vehicle transfers occurring during calendar year 1998, model year 1988 or older vehicles are exempt.

(4) A vehicle sold directly by the manufacturer to any agency of the United States in conformity with contractual specifications.

(b) A transferor of a new vehicle prior to its first transfer for purposes other than resale need not disclose the vehicle's odometer mileage.

(c) A lessor of any of the vehicles listed in paragraph (a) of this section need not notify the lessee of any of these vehicles of the disclosure requirements of §580.7.

[53 FR 29476, Aug. 5, 1988, as amended at 54 FR 35888, Aug. 30, 1989. Redesignated at 62 FR 47765, Sept. 11, 1997; 63 FR 52632, Oct. 1, 1998]

APPENDIX A TO PART 580—SECURE PRINTING PROCESSES AND OTHER SECURE PROCESSES

1. Methods to deter or detect counterfeiting and/or unauthorized reproduction.

(a) Intaglio printing—a printing process utilized in the production of bank-notes and other security documents whereby an engraved plate meets the paper under extremely high pressure forcing the paper into the incisions below the surface of the plate.

(b) Intaglio Printing With Latent Images—a printing process utilized in the production of bank-notes and other security documents whereby an engraved plate meets the paper under extremely high pressure forcing the paper into the incisions below the surface of the plate. The three dimensional nature of intaglio printing creates latent images that aid in verification of authenticity and deter counterfeiting.

(c) High Resolution Printing—a printing process which achieves excellent art clarity

and detail quality approaching that of the intaglio process.

(d) Micro-line Printing—a reduced line of type that appears to be a solid line to the naked eye but contains readable intelligence under strong magnification.

(e) Pantograph Void Feature—wording incorporated into a pantograph by varying screen density in the pantograph. The wording will appear when attempts are made to photocopy on color copiers.

(f) Hologram—a defraction foil substrate, produced from a negative which was made by splitting a laser beam into two separate beams to produce a three dimensional effect.

(g) Security Paper—paper containing a security watermark and/or a security thread.

2. Methods to allow alterations to be visible to the naked eye.

(a) Erasure Sensitive Background Inks—a process whereby the text is printed in a dark color ink over a fine line erasure-sensitive prismatic ink tint.

(b) Security Lamination—retro-reflective security laminate is placed over vital information after it has been entered to allow for detection of attempts to alter this information.

(c) Security Paper—paper which has been chemically treated to detect chemical alterations.

APPENDIX B TO PART 580—DISCLOSURE FORM FOR TITLE

ODOMETER DISCLOSURE STATEMENT

Federal law (and State law, if applicable) requires that you state the mileage in connection with the transfer of ownership. Failure to complete or providing a false statement may result in fines and/or imprisonment.

I state that the odometer now reads _____ (no tenths) miles and to the best of my knowledge that it reflects the actual mileage of the vehicle described herein, unless one of the following statements is checked.

—(1) I hereby certify that to the best of my knowledge the odometer reading reflects the amount of mileage in excess of its mechanical limits.

—(2) I hereby certify that the odometer reading is NOT the actual mileage. WARNING—ODOMETER DISCREPANCY.

(Transferor's Signature)

(Transferee's Signature)

(Printed name)

(Printed name)

Pt. 580, App. C

49 CFR Ch. V (10-1-10 Edition)

Date of Statement _____
Transferee's Name _____
Transferee's Address _____
(Street) _____

(City) (State) (ZIP Code)

APPENDIX C TO PART 580—SEPARATE DISCLOSURE FORM

ODOMETER DISCLOSURE STATEMENT

Federal law (and State law, if applicable) requires that you state the mileage upon transfer of ownership. Failure to complete or providing a false statement may result in fines and/or imprisonment.

I, _____ (transferor's name, Print) state that the odometer now reads _____ (no tenths) miles and to the best of my knowledge that it reflects the actual mileage of the vehicle described below, unless one of the following statements is checked.

—(1) I hereby certify that to the best of my knowledge the odometer reading reflects the amount of mileage in excess of its mechanical limits.

—(2) I hereby certify that the odometer reading is NOT the actual mileage. **WARNING—ODOMETER DISCREPANCY.**

Make _____
Model _____
Body Type _____
Vehicle Identification Number _____
Year _____

(Transferor's Signature)

(Printed name)

Transferor's Address _____
(Street) _____

(City) (State) (ZIP Code)

Date of Statement _____

(Transferee's Signature)

(Printed name)

Transferee's Name _____
Transferee's Address _____
(Street) _____

(City) (State) (ZIP Code)

APPENDIX D TO PART 580—DISCLOSURE FORM FOR LEASED VEHICLE

ODOMETER DISCLOSURE STATEMENT (LEASED VEHICLE)

Federal law (and State law, if applicable) requires that the lessee disclose the mileage to the lessor in connection with the transfer of ownership. Failure to complete or making a false statement may result in fines and/or

imprisonment. Complete disclosure form below and return to lessor.

I, _____ (name of person making disclosure, Print) state that the odometer now reads _____ (no tenths) miles and to the best of my knowledge that it reflects the actual mileage of the vehicle described below, unless one of the following statements is checked.

—(1) I hereby certify that to the best of my knowledge the odometer reading reflects the amount of mileage in excess of its mechanical limits.

—(2) I hereby certify that the odometer reading is NOT the actual mileage.

Make _____
Model _____
Body Type _____
Vehicle Identification Number _____
Year _____

Lessee's Name _____
Lessee's Address _____
(Street) _____

(City) (State) (ZIP Code)

Lessee's Signature _____

Date of Statement _____

Lessor's Name _____

Lessor's Address _____
(Street) _____

(City) (State) (ZIP Code)

Date Disclosure Form Sent to Lessee _____

Date Completed Disclosure Form Received from Lessee _____

Lessor's Signature _____

APPENDIX E TO PART 580—POWER OF ATTORNEY DISCLOSURE FORM

WARNING: This form may be used only when title is physically held by lienholder or has been lost. This form must be submitted to the state by the person exercising powers of attorney. Failure to do so may result in fines and/or imprisonment.

VEHICLE DESCRIPTION

Year _____ Make _____
Model _____ Body _____ Type _____

Vehicle Identification Number _____

PART A. POWER OF ATTORNEY TO DISCLOSE MILEAGE

Federal law (and State Law, if applicable) requires that you state the mileage upon transfer of ownership. Providing a false statement may result in fines and/or imprisonment.

I, _____ (transferor's name, _____ Print) _____ appoint _____ (transferee's name, Print) as my attorney-in-fact, to disclose the mileage, on the title for the vehicle

described above, exactly as stated in my following disclosure.

I state that the odometer now reads _____ (no tenths) miles and to the best of my knowledge that it reflects the actual mileage unless one of the following statements is checked.

____ (1) I hereby certify that to the best of my knowledge the odometer reading reflect the mileage in excess of its mechanical limits.

____ (2) I hereby certify that the odometer reading is NOT the actual mileage. WARNING—ODOMETER DISCREPANCY.

(Transferor's Signature)

(Printed Name)
Transferor's _____ Address _____ (Street) _____
(City) _____ (State) ____ (ZIP Code) _____
Date of Statement _____

(Transferee's Signature)

(Printed Name)
Transferee's Name _____
Transferee's _____ Address _____ (Street) _____
(City) _____ (State) ____ (ZIP Code) _____

PART B. POWER OF ATTORNEY TO REVIEW TITLE DOCUMENTS AND ACKNOWLEDGE DISCLOSURE.

(Part B is invalid unless Part A has been completed.)

I, _____ (transferee's name, _____ Print) appoint _____ (transferor's name, Print) as my attorney-in-fact, to sign the mileage disclosure, on the title for the vehicle described above, only if the disclosure is exactly as the disclosure completed below.

(Transferee's Signature)

(Printed Name)
Transferee's Name _____
Transferee's _____ Address _____ (Street) _____
(City) _____ (State) ____ (ZIP Code) _____

Federal law (and State Law, if applicable) requires that you state the mileage upon transfer of ownership. Providing a false statement may result in fines and/or imprisonment.

I, _____ (transferor's name, Print) state that the odometer now reads _____ (no tenths) miles and to the best of my knowledge that it reflects the actual

mileage unless one of the following statements is checked.

____ (1) I hereby certify that to the best of my knowledge the odometer reading reflect the mileage in excess of its mechanical limits.

____ (2) I hereby certify that the odometer reading is NOT the actual mileage. WARNING—ODOMETER DISCREPANCY.

(Transferor's Signature)

(Printed Name)
Transferor's _____ Address _____ (Street) _____
(City) _____ (State) ____ (ZIP Code) _____
Date of Statement _____

PART C. CERTIFICATION

(To Be Completed When parts A and B Have Been Used)

I, _____, (person exercising above powers of attorney, Print), hereby certify that the mileage I have disclosed on the title document is consistent with that provided to me in the above power of attorney. Further, upon examination of the title and any reassignment documents for the vehicle described above, the mileage disclosure I have made on the title pursuant to the power of attorney is greater than that previously stated on the title and reassignment documents. This certification is not intended to create, nor does it create any new or additional liability under Federal or State law.

(Signature)

(Printed Name)
Address (Street) _____
(City) _____ (State) ____ (ZIP Code) _____
Date _____

[54 FR 9816, Mar. 8, 1989, as amended at 54 FR 35889, Aug. 30, 1989]

PART 581—BUMPER STANDARD

- Sec.
- 581.1 Scope.
- 581.2 Purpose.
- 581.3 Application.
- 581.4 Definitions.
- 581.5 Requirements.
- 581.6 Conditions.
- 581.7 Test procedures.
- 581.8 Exemptions.

AUTHORITY: 49 U.S.C. 32502; 322, 30111, 30115, 30117 and 30166; delegation of authority at 49 CFR 1.50.

§ 581.1

SOURCE: 42 FR 24059, May 12, 1977, unless otherwise noted.

§ 581.1 Scope.

This standard establishes requirements for the impact resistance of vehicles in low speed front and rear collisions.

§ 581.2 Purpose.

The purpose of this standard is to reduce physical damage to the front and rear ends of a passenger motor vehicle from low speed collisions.

§ 581.3 Application.

This standard applies to passenger motor vehicles other than multipurpose passenger vehicles and low-speed vehicles as defined in 49 CFR part 571.3(b).

[63 FR 33217, June 17, 1998]

§ 581.4 Definitions.

All terms defined in 49 U.S.C. 32101 are used as defined therein.

Bumper face bar means any component of the bumper system that contacts the impact ridge of the pendulum test device.

[42 FR 24059, May 12, 1977, as amended at 64 FR 2862, Jan. 19, 1999]

§ 581.5 Requirements.

(a) Each vehicle shall meet the damage criteria of §§ 581.5(c)(1) through 581.5(c)(9) when impacted by a pendulum-type test device in accordance with the procedures of § 581.7(b), under the conditions of § 581.6, at an impact speed of 1.5 m.p.h., and when impacted by a pendulum-type test device in accordance with the procedures of § 581.7(a) at 2.5 m.p.h., followed by an impact into a fixed collision barrier that is perpendicular to the line of travel of the vehicle, while traveling longitudinally forward, then longitudinally rearward, under the conditions of § 581.6, at 2.5 m.p.h.

(b) [Reserved]

(c) *Protective criteria.* (1) Each lamp or reflective device except license plate lamps shall be free of cracks and shall comply with applicable visibility requirements of S5.3.1.1 of Standard No. 108 (§ 571.108 of this chapter). The aim of each headlamp installed on the vehi-

49 CFR Ch. V (10–1–10 Edition)

cle shall be adjustable to within the beam aim inspection limits specified in Table 1 of SAE Recommended Practice J599 AUG97, measured with the aiming method appropriate for that headlamp.

(2) The vehicle's hood, trunk, and doors shall operate in the normal manner.

(3) The vehicle's fuel and cooling systems shall have no leaks or constricted fluid passages and all sealing devices and caps shall operate in the normal manner.

(4) The vehicle's exhaust system shall have no leaks or constrictions.

(5) The vehicle's propulsion, suspension, steering, and braking systems shall remain in adjustment and shall operate in the normal manner.

(6) A pressure vessel used to absorb impact energy in an exterior protection system by the accumulation of gas pressure or hydraulic pressure shall not suffer loss of gas or fluid accompanied by separation of fragments from the vessel.

(7) The vehicle shall not touch the test device, except on the impact ridge shown in Figures 1 and 2, with a force that exceeds 2000 pounds on the combined surfaces of Planes A and B of the test device.

(8) The exterior surfaces shall have no separations of surface materials, paint, polymeric coatings, or other covering materials from the surface to which they are bonded, and no permanent deviations from their original contours 30 minutes after completion of each pendulum and barrier impact, except where such damage occurs to the bumper face bar and the components and associated fasteners that directly attach the bumper face bar to the chassis frame.

(9) Except as provided in § 581.5(c)(8), there shall be no breakage or release of fasteners or joints.

[42 FR 24059, May 12, 1977, as amended at 42 FR 38909, Aug. 1, 1977; 43 FR 40231, Sept. 11, 1978; 47 FR 21837, May 20, 1982; 64 FR 16360, Apr. 5, 1999; 64 FR 49092, Sept. 10, 1999]

§ 581.6 Conditions.

The vehicle shall meet the requirements of § 581.5 under the following conditions.

(a) *General.* (1) The vehicle is at unloaded vehicle weight.

(2) The front wheels are in the straight ahead position.

(3) Tires are inflated to the vehicle manufacturer's recommended pressure for the specified loading condition.

(4) Brakes are disengaged and the transmission is in neutral.

(5) Trailer hitches, license plate brackets, and headlamp washers are removed from the vehicle. Running lights, fog lamps, and equipment mounted on the bumper face bar are removed from the vehicle if they are optional equipment.

(b) *Pendulum test conditions.* The following conditions apply to the pendulum test procedures of §581.7 (a) and (b).

(1) The test device consists of a block with one side contoured as specified in Figure 1 and Figure 2 with the impact ridge made of AISI 4130 steel hardened to 34 Rockwell "C." The impact ridge and the surfaces in Planes A and B of the test device are finished with a surface roughness of 32 as specified by SAE Recommended Practice J449A, June 1963. From the point of release of the device until the onset of rebound, the pendulum suspension system holds Plane A vertical, with the arc described by any point on the impact line lying in a vertical plane (for §581.7(a), longitudinal; for §581.7(b), at an angle of 30° to a vertical longitudinal plane) and having a constant radius of not less than 11 feet.

(2) With Plane A vertical, the impact line shown in Figures 1 and 2 is horizontal at the same height as the test device's center of percussion.

(3) The effective impacting mass of the test device is equal to the mass of the tested vehicle.

(4) When impacted by the test device, the vehicle is at rest on a level rigid concrete surface.

(c) *Barrier test condition.* At the onset of a barrier impact, the vehicle's engine is operating at idling speed in accordance with the manufacturer's specifications. Vehicle systems that are not

necessary to the movement of the vehicle are not operating during impact.

(Authority: Sec. 102, Pub. L. 92-513, 86 Stat. 947 (15 U.S.C. 1912); secs. 103, 119, Pub. L. 89-563, 80 Stat. 718 (15 U.S.C. 1392, 1407); delegation of authority at 49 CFR 1.50 and 501.7)

[42 FR 24059, May 12, 1977, as amended at 42 FR 38909, Aug. 1, 1977; 48 FR 43331, Sept. 23, 1983]

§581.7 Test procedures.

(a) *Longitudinal impact test procedures.*

(1) Impact the vehicle's front surface and its rear surface two times each with the impact line at any height from 16 to 20 inches, inclusive, in accordance with the following procedure.

(2) For impacts at a height of 20 inches, place the test device shown in Figure 1 so that Plane A is vertical and the impact line is horizontal at the specified height.

(3) For impacts at a height between 20 inches and 16 inches, place the test device shown in Figure 2 so that Plane A is vertical and the impact line is horizontal at a height within the range.

(4) For each impact, position the test device so that the impact line is at least 2 inches apart in vertical direction from its position in any prior impact, unless the midpoint of the impact line with respect to the vehicle is to be more than 12 inches apart laterally from its position in any prior impact.

(5) For each impact, align the vehicle so that it touches, but does not move, the test device, with the vehicle's longitudinal centerline perpendicular to the plane that includes Plane A of the test device and with the test device inboard of the vehicle corner test positions specified in §581.7(b).

(6) Move the test device away from the vehicle, then release it to impact the vehicle.

(7) Perform the impacts at intervals of not less than 30 minutes.

(b) *Corner impact test procedure.* (1) Impact a front corner and a rear corner of the vehicle once each with the impact line at a height of 20 inches and impact the other front corner and the other rear corner once each with the impact line at any height from 16 to 20 inches, inclusive, in accordance with the following procedure.

(2) For an impact at a height of 20 inches, place the test device shown in

§ 581.8

Figure 1 so that Plane A is vertical and the impact line is horizontal at the specified height.

(3) For an impact at a height between 16 inches and 20 inches, place the test device shown in Figure 2 so that Plane A is vertical and the impact line is horizontal at a height within the range.

(4) Align the vehicle so that a vehicle corner touches, but does not move, the lateral center of the test device with Plane A of the test device forming an angle of 60 degrees with a vertical longitudinal plane.

(5) Move the test device away from the vehicle, then release it to impact the vehicle.

(6) Perform the impact at intervals of not less than 30 minutes.

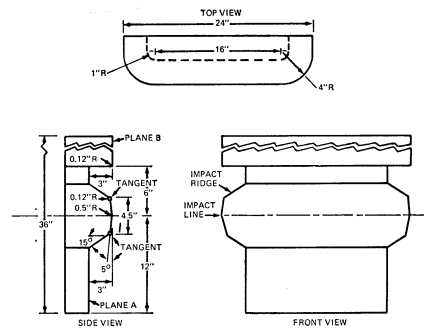


FIGURE 1

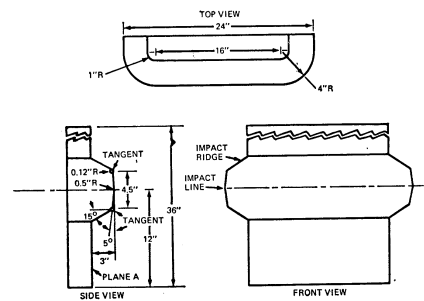


FIGURE 2

[42 FR 24059, May 12, 1977, as amended at 42 FR 38909, Aug. 1, 1977]

§ 581.8 Exemptions.

A manufacturer of a passenger motor vehicle to which a bumper standard issued under this part applies may apply to the Administrator:

(a) For rulemaking as provided in part 552 of this chapter to exempt a class of passenger motor vehicles from all or any part of a bumper standard issued under this part on the basis that the class of vehicles has been manufactured for a special use and that compliance with the standard would unreasonably interfere with the special use of the class of vehicle; or

(b) To exempt a make or model of passenger motor vehicle on the basis set forth in paragraph (a) of this section or part 555 of this chapter.

(c) An application filed for exemption on the basis of paragraph (a) of this section shall contain the information specified in § 555.5 of this chapter, and set forth data, views, and arguments in

support that the vehicle has been manufactured for a special use and that compliance with the bumper standard would interfere unreasonably with the special use of the vehicle.

(d) An application filed for exemption under part 555 of this chapter shall be filed in accordance with the requirements of that part.

(e) The NHTSA shall process exemption applications in accordance with § 555.7 of this chapter. An exemption granted a manufacturer on the basis of paragraph (a) of this section is indefinite in length but expires when the manufacturer ceases production of the exempted vehicle, or when the exempted vehicle as produced has been so modified from its original design that the Administrator decides that it is no longer manufactured for the special use upon which the application for its exemption was based. The Administrator may terminate an exemption in the

manner set forth in §§ 555.8(c) and 555.8(f) of this chapter, and for the reasons set forth in § 555.8(d) of this chapter. An exempted vehicle shall be labeled in accordance with § 555.9 of this chapter. Information relating to an application shall be available to the public in the manner specified in § 555.10 of this chapter.

[64 FR 2862, Jan. 19, 1999]

PART 582—INSURANCE COST INFORMATION REGULATION

Sec.

- 582.1 Scope.
- 582.2 Purpose.
- 582.3 Definitions.
- 582.4 Requirements.
- 582.5 Information form.

AUTHORITY: 49 U.S.C. 32303; delegation of authority at 49 CFR 1.50(f).

SOURCE: 40 FR 4918, Feb. 3, 1975, unless otherwise noted.

§ 582.1 Scope.

This part requires automobile dealers to make available to prospective purchasers information reflecting differences in insurance costs for different makes and models of passenger motor vehicles based upon differences in damage susceptibility and crashworthiness, pursuant to section 201(e) of the Motor Vehicle Information and Cost Savings Act (15 U.S.C. 1941(e)), herein "the Cost Savings Act."

§ 582.2 Purpose.

The purpose of this part is to enable prospective purchasers to compare differences in auto insurance costs for the various makes and models of passenger motor vehicles, based upon differences in damage susceptibility and crashworthiness, and to realize any savings in collision insurance resulting from differences in damageability, and any savings in medical payment insurance resulting from differences in crashworthiness.

§ 582.3 Definitions.

(a) *Statutory definitions.* All terms used in this part which are defined in

section 2 of the Cost Savings Act are used as so defined.

(b) *Definitions used in this part.* (1) *Automobile dealer* means any person who engages in the retail sale of new automobiles as a trade or business.

(2) *Collision insurance* means insurance that reimburses the insured party for physical damage to his property resulting from automobile accidents.

(3) *Insurance cost* means the insurance premium rate, as expressed in appropriate indices, for collision and medical payment, including personal injury protection in no-fault states.

(4) *Medical payment insurance* means insurance that reimburses the insured party for medical expenses sustained by himself, his family, and his passengers in automobile accidents.

[40 FR 4918, Feb. 3, 1975, as amended at 58 FR 12550, Mar. 5, 1993]

§ 582.4 Requirements.

(a) Each automobile dealer shall make available to prospective purchasers, without charge, the information specified in § 582.5, at each location where he or she offers new vehicles for sale.

(b) Each automobile dealer shall maintain a sufficient quantity of booklets containing the information specified in § 582.5 to assure that they are available for retention by prospective purchasers.

(c) The booklets shall be revised to reflect the updated data published by NHTSA each year within 30 days of NHTSA's publication of the data in the FEDERAL REGISTER.

[58 FR 12550, Mar. 5, 1993]

§ 582.5 Information form.

The information made available pursuant to § 582.4 shall be presented in writing in the English language and in not less than 10-point type. It shall be presented in the format set forth below, and shall include the complete explanatory text and the updated data published annually by NHTSA.

MARCH [YEAR TO BE INSERTED]

COMPARISON OF DIFFERENCES IN INSURANCE COSTS FOR PASSENGER CARS, STATION WAGONS/PASSENGER VANS, PICKUPS AND UTILITY VEHICLES ON THE BASIS OF DAMAGE SUSCEPTIBILITY

The National Highway Traffic Safety Administration (NHTSA) has provided the information in this booklet in compliance with Federal law as an aid to consumers considering the purchase of a new vehicle. The booklet compares differences in insurance costs for different makes and models of passenger cars, station wagons/passenger vans, pickups, and utility vehicles on the basis of damage susceptibility. However, it does not indicate a vehicle's relative safety.

The following table contains the best available information regarding the effect of damage susceptibility on insurance premiums. It was taken from data compiled by the Highway Loss Data Institute (HLDI) in its December [YEAR TO BE INSERTED] *Insurance Collision Report*, and reflects the collision loss experience of passenger cars, utility vehicles, light trucks, and vans sold in the United States in terms of the average loss payment per insured vehicle year for [THREE APPROPRIATE YEARS TO BE INSERTED]. NHTSA has not verified the data in this table.

The table represents vehicles' collision loss experience in relative terms, with 100 representing the average for all passenger vehicles. Thus, a rating of 122 reflects a collision loss experience that is 22 percent higher (worse) than average, while a rating of 96 reflects a collision loss experience that is 4 percent lower (better) than average. The table is not relevant for models that have been substantially redesigned for [YEAR TO BE INSERTED], and it does not include information about models without enough claim experience.

Although many insurance companies use the HLDI information to adjust the "base rate" for the collision portion of their insurance premiums, the amount of any such adjustment is usually small. It is unlikely that your total premium will vary more than ten percent depending upon the collision loss experience of a particular vehicle.

If you do not purchase collision coverage or your insurance company does not use the HLDI information, your premium will not vary at all in relation to these rankings.

In addition, different insurance companies often charge different premiums for the same driver and vehicle. Therefore, you should contact insurance companies or their agents directly to determine the actual premium that you will be charged for insuring a particular vehicle.

PLEASE NOTE: In setting insurance premiums, insurance companies mainly rely on factors that are not directly related to the vehicle itself (except for its value). Rather, they mainly consider driver characteristics (such as age, gender, marital status, and driving record), the geographic area in which the vehicle is driven, how many miles are traveled, and how the vehicle is used. Therefore, to obtain complete information about insurance premiums, you should contact insurance companies or their agents directly.

Insurance companies do not generally adjust their premiums on the basis of data reflecting the crashworthiness of different vehicles. However, some companies adjust their premiums for personal injury protection and medical payments coverage if the insured vehicle has features that are likely to improve its crashworthiness, such as air bags and automatic seat belts.

Test data relating to vehicle crashworthiness and rollover ratings are available from NHTSA's New Car Assessment Program (NCAP). NCAP test results demonstrate relative frontal and side crash protection in new vehicles, and relative rollover resistance. Information on vehicles that NHTSA has tested in the NCAP program can be obtained from <http://www.safercar.gov> or by calling NHTSA's toll-free Vehicle Safety Hotline at 1-888-327-4236 (TTY: 1-800-424-9153).

[Insert Table To Be Published Each March by the National Highway Traffic Safety Administration]

If you would like more details about the information in this table, or wish to obtain the complete Insurance Collision Report, please contact HLDI directly, at: Highway Loss Data Institute, 1005 North Glebe Road, Arlington, VA 22201, Tel: (703) 247-1600.

[60 FR 15512, Mar. 24, 1995, as amended at 70 FR 35557, June 21, 2005]

PART 583—AUTOMOBILE PARTS CONTENT LABELING

Sec.

- 583.1 Scope.
- 583.2 Purpose.
- 583.3 Applicability.
- 583.4 Definitions.
- 583.5 Label requirements.
- 583.6 Procedure for determining U.S./Canadian parts content.
- 583.7 Procedure for determining major foreign sources of passenger motor vehicle equipment.
- 583.8 Procedure for determining country of origin for engines and transmissions (for purposes of determining the information specified by §§ 583.5(a)(4) and 583.5(a)(5) only).

- 583.9 Attachment and maintenance of label.
- 583.10 Outside suppliers of passenger motor vehicle equipment.
- 583.11 Allied suppliers of passenger motor vehicle equipment.
- 583.12 Suppliers of engines and transmissions.
- 583.13 Supplier certification and certificates.
- 583.14 Currency conversion rate.
- 583.15 Joint ownership.
- 583.16 Maintenance of records.
- 583.17 Reporting.

AUTHORITY: 49 U.S.C. 32304, 49 CFR 1.50, 501.2(f).

SOURCE: 59 FR 37330, July 21, 1994, unless otherwise noted.

§ 583.1 Scope.

This part establishes requirements for the disclosure of information relating to the countries of origin of the equipment of new passenger motor vehicles.

§ 583.2 Purpose.

The purpose of this part is to aid potential purchasers in the selection of new passenger motor vehicles by providing them with information about the value of the U.S./Canadian and foreign parts content of each vehicle, the countries of origin of the engine and transmission, and the site of the vehicle's final assembly.

§ 583.3 Applicability.

This part applies to manufacturers of new passenger motor vehicles manufactured or imported for sale in the United States, suppliers of passenger motor vehicle equipment, and dealers of new passenger motor vehicles.

§ 583.4 Definitions.

(a) *Statutory terms.* The terms *allied supplier, carline, country of origin, dealer, foreign content, manufacturer, new passenger motor vehicle, of U.S./Canadian origin, outside supplier, passenger motor vehicle, passenger motor vehicle equipment, percentage (by value), State, and value added in the United States and Canada*, defined in 49 U.S.C. 32304(a), are used in accordance with their statutory meanings except as further defined in paragraph (b) of this section.

(b) *Other terms and further definitions.*

(1) *Administrator* means the Administrator of the National Highway Traffic Safety Administration.

(2) *Allied supplier* means a supplier of passenger motor vehicle equipment that is wholly owned by the manufacturer, or in the case of a joint venture vehicle assembly arrangement, any supplier that is wholly owned by one member of the joint venture arrangement. A supplier is considered to be wholly owned by the manufacturer if a common parent company owns both the manufacturer and the supplier, or if a group of related companies own both the manufacturer and the supplier and no outside interests (interests other than the manufacturer itself or companies which own the manufacturer) own the supplier.

(3) *Carline* means a name denoting a group of vehicles which has a degree of commonality in construction (e.g., body, chassis). Carline does not consider any level of decor or opulence and is not generally distinguished by such characteristics as roof line, number of doors, seats, or windows, except for light duty trucks. Carline is not distinguished by country of manufacture, final assembly point, engine type, or driveline. Light duty trucks are considered to be different carlines than passenger cars. A carline includes all motor vehicles of a given nameplate. Special purpose vehicles, vans, and pickup trucks are classified as separate carlines.

(4) *Final assembly* means all operations involved in the assembly of a vehicle, performed at the final assembly point including but not limited to assembly of body panels, painting, final chassis assembly, trim installation, except engine and transmission fabrication and assembly and the fabrication of motor vehicle equipment components produced at the same final assembly point using forming processes such as stamping, machining or molding processes.

(5) *Final assembly point* means the plant, factory, or other place, which is a building or series of buildings in close proximity, where a new passenger motor vehicle is produced or assembled from passenger motor vehicle equipment and from which such vehicle is delivered to a dealer or importer in

§583.5

49 CFR Ch. V (10–1–10 Edition)

such a condition that all component parts necessary to the mechanical operation of such automobile are included with such vehicle whether or not such component parts are permanently installed in or on such vehicle. For multi-stage vehicles, the final assembly point is the location where the first stage vehicle is assembled.

(6) *Outside supplier* means:

(i) A non-allied supplier of passenger motor vehicle equipment to a manufacturer's allied supplier and

(ii) Anyone other than an allied supplier who ships directly to the manufacturer's final assembly point.

(7) *Passenger motor vehicle equipment* means any system, subassembly, or component received at the final assembly point for installation on, or attachment to, such vehicle at the time of its initial shipment by the manufacturer to a dealer for sale to an ultimate purchaser. Passenger motor vehicle equipment also includes any system, subassembly, or component received by an allied supplier from an outside supplier for incorporation into equipment supplied by the allied supplier to the manufacturer with which it is allied.

(8) *Person* means an individual, partnership, corporation, business trust, or any organized group of persons.

(9) *Ultimate purchaser* means with respect to any new passenger motor vehicle, the first person, other than a dealer purchasing in its capacity as a dealer, who in good faith purchases such new passenger motor vehicle for purposes other than resale.

[59 FR 37330, July 21, 1994, as amended at 64 FR 40780, July 28, 1999]

§583.5 Label requirements.

(a) Except as provided in paragraphs (f) and (g) of this section, each manufacturer of new passenger motor vehicles shall cause to be affixed to each passenger motor vehicle manufactured on or after October 1, 1994, a label that provides the following information:

(1) *U.S./Canadian parts content.* The overall percentage, by value, of the passenger motor vehicle equipment that was installed on vehicles within the carline of which the vehicle is part, and that originated in the United States and/or Canada (the procedure

for determining U.S./Canadian Parts Content is set forth in §583.6);

(2) *Major sources of foreign parts content.* The names of any countries other than the United States and Canada which contributed at least 15 percent of the average overall percentage, by value, of the passenger motor vehicle equipment installed on vehicles within the carline of which the vehicle is part, and the percentages attributable to each such country (if there are more than two such countries, the manufacturer need only provide the information for the two countries with the highest percentages; the procedure for determining major foreign sources of passenger motor vehicle equipment is set forth in §583.7);

(3) *Final assembly point.* The city, state (in the case of vehicles assembled in the United States), and country of the final assembly point of the passenger motor vehicle;

(4) *Country of origin for the engine.* The country of origin of the passenger motor vehicle's engine (the procedure for making this country of origin determination is set forth in §583.8);

(5) *Country of origin for the transmission.* The country of origin of the passenger motor vehicle's transmission (the procedure for making this country of origin determination is set forth in §583.8);

(6) *Explanatory note.* A statement which explains that parts content does not include final assembly, distribution, or other non-parts costs.

(b) Except as provided in paragraphs (e), (f) and (g) of this section, the label required under paragraph (a) of this section shall read as follows, with the specified information inserted in the places indicated (except that if there are no major sources of foreign parts content, omit the section "Major Sources of Foreign Parts Content"):

PARTS CONTENT INFORMATION

For vehicles in this carline:

U.S./Canadian Parts Content: (insert number) %

Major Sources of Foreign Parts Content:

(Name of country with highest percentage): (insert number) %

(Name of country with second highest percentage): (insert number) %

NOTE: Parts content does not include final assembly, distribution, or other non-parts costs.

For this vehicle:

Final Assembly Point: (city, state, country)
Country of Origin:

Engine: (name of country)

Transmission: (name of country)

(c) The percentages required to be provided under paragraph (a) of this section may be rounded by the manufacturer to the nearest 5 percent.

(d) The label required by paragraph (a) of this section shall:

(1) Be placed in a prominent location on each vehicle where it can be read from the exterior of the vehicle with the doors closed, and may be either part of the Monroney price information label required by 15 U.S.C. 1232, part of the fuel economy label required by 15 U.S.C. 2006, or a separate label. A separate label may include other consumer information.

(2)(i) Be printed in letters that have a color that contrasts with the background of the label; and

(ii) Have the information required by paragraphs (a)(1) through (5) of this section vertically centered on the label in boldface capital letters and numerals of 12 point size or larger; and

(iii) Have the information required by paragraph (a)(6) of this section in type that is two points smaller than the information required by paragraphs (a)(1) through (5) of this section.

(3) In the case of a label that is included as part of the Monroney price information label or fuel economy label, or a separate label that includes other consumer information, be separated from all other information on those labels by a solid line that is a minimum of three points in width.

(4) The information required by paragraphs (a)(1) through (6) of this section shall be immediately preceded by the words, "PARTS CONTENT INFORMATION," in boldface, capital letters that are 12 point size or larger.

(e) *Carlines assembled in the U.S./Canada and in one or more other countries.*

(1) If a carline is assembled in the U.S. and/or Canada, and in one or more other countries, the manufacturer may, at its option, add the following additional information at the end of the explanatory note specified in (a)(6),

with the specified information inserted in the places indicated:

This carline is assembled in the U.S. and/or Canada, and in [insert name of each other country]. The U.S./Canadian parts content for the portion of the carline assembled in [insert name of country, treating the U.S. and Canada together, i.e., U.S./Canada] is []%.

(2) A manufacturer selecting this option shall divide the carline for purposes of this additional information into the following portions: the portion assembled in the U.S./Canada and the portions assembled in each other country.

(3) A manufacturer selecting this option for a particular carline shall provide the specified additional information on the labels of all vehicles within the carline, providing the U.S./Canadian content that corresponds to the U.S./Canadian content of the manufacturing location shown as the final assembly point (with all U.S. and Canadian locations considered as a single assembly point) on the label.

(f) A final stage manufacturer of vehicles assembled in multiple stages need not provide the U.S./Canadian Parts Content or Major Foreign Sources items of the label otherwise required under paragraphs (a)(1) and (2) of this section.

(g) A manufacturer that produces a total of fewer than 1000 passenger motor vehicles in a model year need not provide the U.S./Canadian Parts Content or Major Foreign Sources items of the label otherwise required under paragraphs (a)(1) and (2) of this section.

(h) *Requests for information and certifications relevant to information on the label.* (1) Each manufacturer and allied supplier shall request its suppliers to provide directly to it the information and certifications specified by this part which are necessary for the manufacturer/allied supplier to carry out its responsibilities under this part. The information shall be requested sufficiently early to enable the manufacturer to meet the timing requirements specified by this part.

(2) For requests made by manufacturers or allied suppliers to outside suppliers:

§ 583.6

(i) The requester shall indicate that the request is being made pursuant to 49 CFR part 583, and that the regulation is administered by the National Highway Traffic Safety Administration;

(ii) The requester shall indicate that 49 CFR part 583 requires outside suppliers to provide specified information upon the request of a manufacturer or allied supplier to which it supplies passenger motor vehicle equipment and that, to the best of the requester's knowledge, the outside supplier is required to provide the requested information;

(iii) If any information other than that required by 49 CFR part 583 is requested, the requester shall indicate which information is required by 49 CFR part 583 and which is not;

(iv) The requester shall indicate that 49 CFR part 583 specifies that while information may be requested by an earlier date, the outside supplier is not required to provide the information until the date specified by the requester or the date 45 days after receipt of the request, whichever is later.

(i) *Carlines assembled in more than one assembly plant.* (1) If a carline is assembled in more than one assembly plant, the manufacturer may, at its option, add the following additional information at the end of the explanatory note specified in paragraph (a)(6) of this section, with the specified information inserted in the places indicated:

Two or more assembly plants produce the vehicles in this carline. The vehicles assembled at the plant where this vehicle was assembled have a U.S./Canadian parts content of []%.

(2) A manufacturer selecting this option shall divide the carline for purposes of this additional information into portions representing each assembly plant.

(3) A manufacturer selecting this option for a particular carline shall provide the specified additional information on the labels of all vehicles within the carline.

[59 FR 37330, July 21, 1994, as amended at 60 FR 14229, Mar. 16, 1995; 60 FR 47893, Sept. 15, 1995; 64 FR 40780, July 28, 1999]

49 CFR Ch. V (10-1-10 Edition)

§ 583.6 Procedure for determining U.S./Canadian parts content.

(a) Each manufacturer, except as specified in § 583.5 (f) and (g), shall determine the percentage U.S./Canadian Parts Content for each carline on a model year basis. This determination shall be made before the beginning of each model year. Items of equipment produced at the final assembly point (but not as part of final assembly) are treated in the same manner as if they were supplied by an allied supplier. All value otherwise added at the final assembly point and beyond, including all final assembly costs, is excluded from the calculation of U.S./Canadian parts content. The country of origin of nuts, bolts, clips, screws, pins, braces, gasoline, oil, blackout, phosphate rinse, windshield washer fluid, fasteners, tire assembly fluid, rivets, adhesives, grommets, and wheel weights, used in final assembly of the vehicle, is considered to be the country where final assembly of the vehicle takes place.

(b) *Determining the value of items of equipment.* (1) For items of equipment received at the final assembly point, the value is the price paid by the manufacturer for the equipment as delivered to the final assembly point.

(2) For items of equipment produced at the final assembly point (but not as part of final assembly), the value is the fair market price that a manufacturer of similar size and location would pay a supplier for such equipment.

(3) For items of equipment received at the factory or plant of an allied supplier, the value is the price paid by the allied supplier for the equipment as delivered to its factory or plant.

(c) *Determining the U.S./Canadian percentage of the value of items of equipment.* (1) Equipment supplied by an outside supplier to a manufacturer or allied supplier is considered:

(i) 100 percent U.S./Canadian, if 70 percent or more of its value is added in the United States and/or Canada; and

(ii) To otherwise have the actual percent of its value added in the United States and/or Canada, rounded to the nearest five percent.

(2) The extent to which an item of equipment supplied by an allied supplier is considered U.S./Canadian is determined by dividing the value added

in the United States and/or Canada by the total value of the equipment. The resulting number is multiplied by 100 to determine the percentage U.S./Canadian content of the equipment.

(3) In determining the value added in the United States and/or Canada of equipment supplied by an allied supplier, any equipment that is delivered to the allied supplier by an outside supplier and is incorporated into the allied supplier's equipment, is considered:

(i) 100 percent U.S./Canadian, if at least 70 percent of its value is added in the United States and/or Canada; and

(ii) To otherwise have the actual percent of its value added in the United States and/or Canada, rounded to the nearest five percent.

(4)(i) Value added in the United States and/or Canada by an allied supplier or outside supplier includes—

(A) The value added in the U.S. and/or Canada for materials used by the supplier, determined according to (4)(ii) for outside suppliers and (4)(iii) for allied suppliers, plus,

(B) For passenger motor vehicle equipment assembled or produced in the U.S. or Canada, the value of the difference between the price paid by the manufacturer or allied supplier for the equipment, as delivered to its factory or plant, and the total value of the materials in the equipment.

(ii) Outside suppliers of passenger motor vehicle equipment will determine the value added in the U.S. and/or Canada for materials in the equipment as specified in paragraphs (A) and (B).

(A)(I) For any material used by the supplier which was produced or assembled in the U.S. or Canada, the supplier will subtract from the total value of the material any value that was not added in the U.S. and/or Canada. The determination of the value that was not added in the U.S. and/or Canada shall be a good faith estimate based on information that is available to the supplier, e.g., information in its records, information it can obtain from its suppliers, the supplier's knowledge of manufacturing processes, etc.

(2) The supplier shall consider the amount of value added and the location in which that value was added—

(i) At each earlier stage, counting from the time of receipt of a material

by the supplier, back to and including the two closest stages each of which represented a substantial transformation into a new and different product with a different name, character and use.

(ii) The value of materials used to produce a product in the earliest of these two substantial transformation stages shall be treated as value added in the country in which that stage occurred.

(B) For any material used by the supplier which was imported into the United States or Canada from a third country, the value added in the United States and/or Canada is presumed to be zero. However, if documentation is available to the supplier which identifies value added in the United States and/or Canada for that material (determined according to the principles set forth in (A), such value added in the United States and/or Canada is counted.

(iii) Allied suppliers of passenger motor vehicle equipment shall determine the value that is added in the U.S. and/or Canada for materials in the equipment in accordance with (c)(3).

(iv) For the minor items listed in the §583.4 definition of "passenger motor vehicle equipment" as being excluded from that term, outside and allied suppliers may, to the extent that they incorporate such items into their equipment, treat the cost of the minor items as value added in the country of assembly.

(v) For passenger motor vehicle equipment which is imported into the territorial boundaries of the United States or Canada from a third country, the value added in the United States and/or Canada is presumed to be zero. However, if documentation is available to the supplier which identifies value added in the United States and/or Canada for that equipment (determined according to the principles set forth in the rest of (c)(4)), such value added in the United States and/or Canada is counted.

(vi) The payment of duty does not result in value added in the United States and/or Canada.

(5) Except as provided in paragraph (c)(6) of this section, if a manufacturer

or allied supplier does not receive information from one or more of its suppliers concerning the U.S./Canadian content of particular equipment, the U.S./Canadian content of that equipment is considered zero. This provision does not affect the obligation of manufacturers and allied suppliers to request this information from their suppliers or the obligation of the suppliers to provide the information.

(6) If a manufacturer or allied supplier requests information in a timely manner from one or more of its outside suppliers concerning the U.S./Canadian content of particular equipment, but does not receive that information despite a good faith effort to obtain it, the manufacturer or allied supplier may make its own good faith value added determinations, subject to the following provisions:

(i) The manufacturer or allied supplier shall make the same value added determinations as would be made by the outside supplier;

(ii) The manufacturer or allied supplier shall consider the amount of value added and the location in which the value was added for all of the stages that the outside supplier would be required to consider;

(iii) The manufacturer or allied supplier may determine that particular value is added in the United States and/or Canada only if it has a good faith basis to make that determination;

(iv) A manufacturer and its allied suppliers may, on a combined basis, make value added determinations for no more than 10 percent, by value, of a carline's total parts content from outside suppliers;

(v) Value added determinations made by a manufacturer or allied supplier under this paragraph shall have the same effect as if they were made by the outside supplier;

(vi) This provision does not affect the obligation of outside suppliers to provide the requested information.

(d) *Determination of the U.S./Canadian percentage of the total value of a carline's passenger motor vehicle equipment.* The percentage of the value of a carline's passenger motor vehicle equipment that is U.S./Canadian is determined by—

(1) Adding the total value of all of the equipment (regardless of country of origin) expected to be installed in that carline during the next model year;

(2) Dividing the value of the U.S./Canadian content of such equipment by the amount calculated in paragraph (d)(1) of this section, and

(3) Multiplying the resulting number by 100.

(e) *Alternative calculation procedures.*

(1) A manufacturer may submit a petition to use calculation procedures based on representative or statistical sampling, as an alternative to the calculation procedures specified in this section to determine U.S./Canadian parts content and major sources of foreign parts content.

(2) Each petition must—

(i) Be submitted at least 120 days before the manufacturer would use the alternative procedure;

(ii) Be written in the English language;

(iii) Be submitted in three copies to: Administrator, National Highway Traffic Safety Administration, 400 Seventh Street SW., Washington, DC 20590;

(iv) State the full name and address of the manufacturer;

(v) Set forth in full the data, views and arguments of the manufacturer that would support granting the petition, including—

(A) the alternative procedure, and

(B) analysis demonstrating that the alternative procedure will produce substantially equivalent results to the procedure set forth in this section;

(vi) Specify and segregate any part of the information and data submitted in the petition that is requested to be withheld from public disclosure in accordance with part 512 of this chapter (the basic alternative procedure and basic supporting analysis must be provided as public information, but confidential business information may also be used in support of the petition).

(3) The NHTSA publishes in the FEDERAL REGISTER, affording opportunity for comment, a notice of each petition containing the information required by this part. A copy of the petition is placed in the public docket. However, if NHTSA finds that a petition does not contain the information required by this part, it so informs the petitioner,

pointing out the areas of insufficiency and stating that the petition will not receive further consideration until the required information is submitted.

(4) If the Administrator determines that the petition does not contain adequate justification, he or she denies it and notifies the petitioner in writing, explaining the reasons for the denial. A copy of the letter is placed in the public docket.

(5) If the Administrator determines that the petition contains adequate justification, he or she grants it, and notifies the petitioner in writing. A copy of the letter is placed in the public docket.

(6) The Administrator may attach such conditions as he or she deems appropriate to a grant of a petition, which the manufacturer must follow in order to use the alternative procedure.

[60 FR 47894, Sept. 15, 1995; as amended at 61 FR 46390, Sept. 3, 1996; 62 FR 33761, June 23, 1997; 64 FR 40780, July 28, 1999]

§ 583.7 Procedure for determining major foreign sources of passenger motor vehicle equipment.

(a) Each manufacturer, except as specified in § 583.5(f) and (g), shall determine the countries, if any, which are major foreign sources of passenger motor vehicle equipment and the percentages attributable to each such country for each carline on a model year basis, before the beginning of each model year. The manufacturer need only determine this information for the two such countries with the highest percentages. Items of equipment produced at the final assembly point (but not as part of final assembly) are treated in the same manner as if they were supplied by an allied supplier. In making determinations under this section, the U.S. and Canada are treated together as if they were one (non-foreign) country. The country of origin of nuts, bolts, clips, screws, pins, braces, gasoline, oil, blackout, phosphate rinse, windshield washer fluid, fasteners, tire assembly fluid, rivets, adhesives, grommets, and wheel weights, used in final assembly of the vehicle, is considered to be the country where final assembly of the vehicle takes place.

(b) *Determining the value of items of equipment.* The value of each item of equipment is determined in the manner specified in § 583.6(b).

(c) *Determining the country of origin of items of equipment.* (1) Except as provided in (c)(2), the country of origin of each item is the country which contributes the greatest amount of value added to that item (treating the U.S. and Canada together).

(2) Instead of making country of origin determinations in the manner specified in (c)(1), a manufacturer may, at its option, use any other methodology that is used for customs purposes (U.S. or foreign), so long as a consistent methodology is employed for all items of equipment, and the U.S. and Canada are treated together.

(d) *Determination of the percentage of the total value of a carline's passenger motor vehicle equipment which is attributable to individual countries other than the U.S. and Canada.* The percentage of the value of a carline's passenger motor vehicle equipment that is attributable to each country other than the U.S. and Canada is determined on a model year basis by—

(1) Adding up the total value of all of the passenger motor vehicle equipment (regardless of country of origin) expected to be installed in that carline during the next model year;

(2) Adding up the value of such equipment which originated in each country other than the U.S. or Canada;

(3) Dividing the amount calculated in paragraph (d)(2) of this section for each country by the amount calculated in paragraph (d)(1) of this section, and multiplying each result by 100.

(e) A country is a major foreign source of passenger motor vehicle equipment for a carline only if the country is one other than the U.S. or Canada and if 15 or more percent of the total value of the carline's passenger motor vehicle equipment is attributable to the country.

(f) In determining the percentage of the total value of a carline's passenger motor vehicle equipment which is attributable to individual countries other than the U.S. and Canada, no value which is counted as U.S./Canadian parts content is also counted as being

§ 583.8

value which originated in a country other than the U.S. or Canada.

[59 FR 37330, July 21, 1994, as amended at 60 FR 47895, Sept. 15, 1995; 64 FR 40781, July 28, 1999]

§ 583.8 Procedure for determining country of origin for engines and transmissions (for purposes of determining the information specified by §§ 583.5(a)(4) and 583.5(a)(5) only).

(a) Each supplier of an engine or transmission shall determine the country of origin once a year for each engine and transmission. The origin of engines shall be calculated for engines of the same displacement produced at the same plant. The origin for transmissions shall be calculated for transmissions of the same type produced at the same plant. Transmissions are of the same type if they have the same attributes including: Drive line application, number of forward gears, controls, and layout. The U.S. and Canada are treated separately in making such determination.

(b) The value of an engine or transmission is determined by first adding the prices paid by the manufacturer of the engine/transmission for each component comprising the engine/transmission, as delivered to the assembly plant of the engine/transmission, and the fair market value of each individual part produced at the plant. The assembly and labor costs incurred for the final assembly of the engine/transmission are then added to determine the value of the engine or transmission.

(c) *Determining the country of origin of components.* (1) Except as provided in (c)(2), the country of origin of each item of equipment is the country which contributes the greatest amount of value added to that item (the U.S. and Canada are treated separately).

(2) Instead of making country of origin determinations in the manner specified in (c)(1), a manufacturer may, at its option, use any other methodology that is used for customs purposes (U.S. or foreign), so long as a consistent methodology is employed for all components.

(d) *Determination of the total value of an engine/transmission which is attrib-*

49 CFR Ch. V (10-1-10 Edition)

utable to individual countries. The value of an engine/transmission that is attributable to each country is determined by adding the total value of all of the components installed in that engine/transmission which originated in that country. For the country where final assembly of the engine/transmission takes place, the assembly and labor costs incurred for such final assembly are also added.

(e) The country of origin of each engine and the country of origin of each transmission is the country which contributes the greatest amount of value added to that item of equipment (the U.S. and Canada are treated separately).

[59 FR 37330, July 21, 1994, as amended at 60 FR 47895, Sept. 15, 1995; 64 FR 40781, July 28, 1999]

§ 583.9 Attachment and maintenance of label.

(a) *Attachment of the label.* (1) Except as provided in (a)(2), each manufacturer shall cause the label required by § 583.5 to be affixed to each new passenger motor vehicle before the vehicle is delivered to a dealer.

(2) For vehicles which are delivered to a dealer prior to the introduction date for the model in question, each manufacturer shall cause the label required by § 583.5 to be affixed to the vehicle prior to such introduction date.

(b) *Maintenance of the label.* (1) Each dealer shall cause to be maintained each label on the new passenger motor vehicles it receives until after such time as a vehicle has been sold to a consumer for purposes other than resale.

(2) If the manufacturer of a passenger motor vehicle provides a substitute label containing corrected information, the dealer shall replace the original label with the substitute label.

(3) If a label becomes damaged so that the information it contains is not legible, the dealer shall replace it with an identical, undamaged label.

§ 583.10 Outside suppliers of passenger motor vehicle equipment.

(a) For each unique type of passenger motor vehicle equipment for which a

manufacturer or allied supplier requests information, the outside supplier shall provide the manufacturer/allied supplier with a certificate providing the following information:

(1) The name and address of the supplier;

(2) A description of the unique type of equipment;

(3) The price of the equipment to the manufacturer or allied supplier;

(4) A statement that the equipment has, or does not have, at least 70 percent of its value added in the United States and Canada, determined under § 583.6(c);

(5) For equipment which has less than 70 percent of its value added in the United States and Canada,

(i) The country of origin of the equipment, determined under § 583.7(c); and

(ii) The percent of its value added in the United States and Canada, to the nearest 5 percent, determined under § 583.6(c).

(6) For equipment that may be used in an engine or transmission, the country of origin of the equipment, determined under § 583.8(c);

(7) A certification for the information, pursuant to § 583.13, and the date (at least giving the month and year) of the certification.

(8) A single certificate may cover multiple items of equipment.

(b) The information and certification required by paragraph (a) of this section shall be provided to the manufacturer or allied supplier no later than 45 days after receipt of the request, or the date specified by the manufacturer/allied supplier, whichever is later. (A manufacturer or allied supplier may request that the outside supplier voluntarily provide the information and certification at an earlier date.)

(c)(1) Except as provided in paragraph (c)(2) of this section, the information provided in the certificate shall be the supplier's best estimates of price, content, and country of origin for the unique type of equipment expected to be supplied during the 12 month period beginning on the first July 1 after receipt of the request. If the unique type of equipment supplied by the supplier is expected to vary with respect to price, content, and country of origin during that period, the supplier shall

base its estimates on expected averages for these factors.

(2) The 12 month period specified in (c)(1) may be varied in time and length by the manufacturer or allied supplier if it determines that the alteration is not likely to result in less accurate information being provided to consumers on the label required by this part.

(d) For outside suppliers of engines and transmissions, the information and certification required by this section is in addition to that required by § 583.12.

[59 FR 37330, July 21, 1994, as amended at 64 FR 40781, July 28, 1999]

§ 583.11 Allied suppliers of passenger motor vehicle equipment.

(a) For each unique type of passenger motor vehicle equipment which an allied supplier supplies to the manufacturer with which it is allied, the allied supplier shall provide the manufacturer with a certificate providing the following information:

(1) The name and address of the supplier;

(2) A description of the unique type of equipment;

(3) The price of the equipment to the manufacturer;

(4) The percentage U.S./Canadian content of the equipment, determined under § 583.6(c);

(5) The country of origin of the equipment, determined under § 583.7(c);

(6) For equipment that may be used in an engine or transmission, the country of origin of the equipment, determined under § 583.8(c);

(7) A certification for the information, pursuant to § 583.13, and the date (at least giving the month and year) of the certification.

(8) A single certificate may cover multiple items of equipment.

(b)(1) Except as provided in paragraph (b)(2) of this section, the information provided in the certificate shall be the supplier's best estimates of price, content, and country of origin for the unique type of equipment expected to be supplied during the 12 month period beginning on the first July 1 after receipt of the request. If the unique type of equipment supplied by the supplier is expected to vary with respect to price, content, and country

§ 583.12

of origin during that period, the supplier shall base its estimates on expected averages for these factors.

(2) The 12 month period specified in (b)(1) may be varied in time and length by the manufacturer if it determines that the alteration is not likely to result in less accurate information being provided to consumers on the label required by this part.

(c) [Reserved]

(d) For allied suppliers of engines and transmissions, the information and certification required by this section is in addition to that required by § 583.12.

§ 583.12 Suppliers of engines and transmissions.

(a) For each engine or transmission for which a manufacturer or allied supplier requests information, the supplier of such engine or transmission shall provide the manufacturer or allied supplier with a certificate providing the following information:

(1) The name and address of the supplier;

(2) A description of the engine or transmission;

(3) The country of origin of the engine or transmission, determined under § 583.8;

(4) A certification for the information, pursuant to § 583.13, and the date (at least giving the month and year) of the certification.

(b) The information provided in the certificate shall be the supplier's best estimate of country of origin for the unique type of engine or transmission. If the unique type of equipment used in the engine or transmission is expected to vary with respect to price, content, and country of origin during that period, the supplier shall base its country of origin determination on expected averages for these factors.

(c) The information and certification required by paragraph (a) of this section shall be provided by outside suppliers to the manufacturer or allied supplier no later than 45 days after receipt of the request, or the date specified by the manufacturer/allied supplier, whichever is later. (A manufacturer or allied supplier may request that the outside supplier voluntarily provide the information and certification at an earlier date.)

49 CFR Ch. V (10–1–10 Edition)

(d) In the event that, during a model year, a supplier of engines or transmissions produces an engine of a new displacement or transmission of a new type or produces the same engine displacement or transmission in a different plant, the supplier shall notify the manufacturer of the origin of the new engine or transmission prior to shipment of the first engine or transmission that will be installed in a passenger motor vehicle intended for public sale.

(e) A single certificate may cover multiple engines or transmissions. If a certificate provided in advance of the delivery of an engine or transmission becomes inaccurate because of changed circumstances, a corrected certificate shall be provided no later than the time of delivery of the engine or transmission.

(f) For suppliers of engines and transmissions, the information and certification required by this section is in addition to that required by §§ 583.10 and 583.11.

§ 583.13 Supplier certification and certificates.

Each supplier shall certify the information on each certificate provided under §§ 583.10, 583.11, and 583.12 by including the following phrase on the certificate: "This information is certified in accordance with DOT regulations." The phrase shall immediately precede the other information on the certificate. The certificate may be submitted to a manufacturer or allied supplier in any mode (e.g., paper, electronic) provided the mode contains all information in the certificate.

§ 583.14 Currency conversion rate.

For purposes of calculations of content value under this part, manufacturers and suppliers shall calculate exchange rates using the methodology set forth in this section.

(a) *Manufacturers.* (1) Unless a manufacturer has had a petition approved by the Environmental Protection Agency under 40 CFR 600.511–80(b)(1), for all calculations made by the manufacturer as a basis for the information provided on the label required by § 583.5, manufacturers shall take the mean of the exchange rates in effect at the end of

each quarter set by the Federal Reserve Bank of New York for twelve calendar quarters prior to and including the calendar quarter ending one year prior to the date that the manufacturer submits information for a carline under § 583.17.

(2) A manufacturer that has had a petition approved by the Environmental Protection Agency under 40 CFR 600.511-80(b)(1), which provides for a different method of determining exchange rates, shall use the same method as a basis for the information provided on the label required by § 583.5, and shall inform the Administrator of the exchange rate method it is using at the time the information required by § 583.5 is submitted.

(b) *Suppliers.* For all calculations underlying the information provided on each certificate required by §§ 583.10, 583.11, and 583.12, suppliers shall take the mean of the exchange rates in effect at the end of each quarter set by the Federal Reserve Bank of New York for twelve calendar quarters prior to and including the calendar quarter ending one year prior to the date of such certificate.

§ 583.15 Joint ownership.

(a) A carline jointly owned and/or produced by more than one manufacturer shall be attributed to the single manufacturer that markets the carline, subject to paragraph (b) of this section.

(b)(1) The joint owners of a carline may designate, by written agreement, the manufacturer of record of that carline.

(2) The manufacturer of record is responsible for compliance with all the manufacturer requirements in this part with respect to the jointly owned carline. However, carline determinations must be consistent with § 583.4(3).

(3) A designation under this section of a manufacturer of record is effective beginning with the first model year beginning after the conclusion of the written agreement, or, if the joint owners so agree in writing, with a specified later model year.

(4) Each manufacturer of record shall send to the Administrator written notification of its designation as such not later than 30 days after the conclusion

of the written agreement, and state the carline of which it is considered the manufacturer, the names of the other persons which jointly own the carline, and the name of the person, if any, formerly considered to be the manufacturer of record.

(5) The joint owners of a carline may change the manufacturer of record for a future model year by concluding a written agreement before the beginning of that model year.

(6) The allied suppliers for the jointly owned carline are the suppliers that are wholly owned by any of the manufacturers of the jointly owned carline.

§ 583.16 Maintenance of records.

(a) *General.* Each manufacturer of new passenger motor vehicles and each supplier of passenger motor vehicle equipment subject to this part shall establish, maintain, and retain in organized and indexed form, records as specified in this section. All records, including the certificates provided by suppliers, may be stored in any mode provided the mode contains all information in the records and certificates.

(b) *Manufacturers.* Each manufacturer shall maintain all records which provide a basis for the information it provides on the labels required by § 583.5, including, but not limited to, certificates from suppliers, parts lists, calculations of content, and relevant contracts with suppliers. The records shall be maintained for five years after December 31 of the model year to which the records relate.

(c) *Suppliers.* Each supplier shall maintain all records which form a basis for the information it provides on the certificates required by §§ 583.10, 583.11, and 583.12, including, but not limited to, calculations of content, certificates from suppliers, and relevant contracts with manufacturers and suppliers. The records shall be maintained for six years after December 31 of the calendar year set forth in the date of each certificate.

§ 583.17 Reporting.

For each model year, manufacturers shall submit to the Administrator 3 copies of the information required by § 583.5(a) to be placed on a label for each carline. The information for each

Pt. 585

49 CFR Ch. V (10–1–10 Edition)

carline shall be submitted not later than the date the first vehicle of the carline is offered for sale to the ultimate purchaser.

PART 585—PHASE-IN REPORTING REQUIREMENTS

Subpart A—General

Sec.

- 585.1 Definitions.
- 585.2 Phase-in reports.
- 585.3 Vehicles produced by more than one manufacturer.
- 585.4 Petitions to extend period to file report.

Subpart B—Advanced Air Bag Phase-in Reporting Requirements

- 585.11 Scope.
- 585.12 Purpose.
- 585.13 Applicability.
- 585.14 Definitions.
- 585.15 Reporting requirements.
- 585.16 Records.

Subpart C—Rear Inboard Lap/Shoulder Belt Phase-in Reporting Requirements

- 585.21 Scope.
- 585.22 Purpose.
- 585.23 Applicability.
- 585.24 Reporting requirements.
- 585.25 Records.

Subpart D—Appendix A–1 of FMVSS No. 208 Phase-in Reporting Requirements

- 585.31 Scope.
- 585.32 Purpose.
- 585.33 Applicability.
- 585.34 Definitions.
- 585.35 Response to inquiries.
- 585.36 Reporting requirements.
- 585.37 Records.

Subpart E—Fuel System Integrity Phase-in Reporting Requirements

- 585.41 Scope.
- 585.42 Purpose.
- 585.43 Applicability.
- 585.44 Response to inquiries.
- 585.45 Reporting requirements.
- 585.46 Records.

Subpart F—Tires for Motor Vehicles with a GVWR of 10,000 Pounds or Less Phase-in Reporting Requirements

- 585.51 Scope.
- 585.52 Purpose.
- 585.53 Applicability.
- 585.54 Response to inquiries.

- 585.55 Reporting requirements.
- 585.56 Records.

Subpart G—Tire Pressure Monitoring System Phase-in Reporting Requirements

- 585.61 Scope.
- 585.62 Purpose.
- 585.63 Applicability.
- 585.64 Definitions.
- 585.65 Response to inquiries.
- 585.66 Reporting requirements.
- 585.67 Records.
- 585.68 Petition to extend period to file report.

Subpart H—Side Impact Protection Phase-in Reporting Requirements

- 585.71 Scope.
- 585.72 Purpose.
- 585.73 Applicability.
- 585.74 Definitions.
- 585.75 Response to inquiries.
- 585.76 Reporting requirements.
- 585.77 Records.

Subpart I—Electronic Stability Control System Phase-in Reporting Requirements

- 585.81 Scope.
- 585.82 Purpose.
- 585.83 Applicability.
- 585.84 Definitions.
- 585.85 Response to inquiries.
- 585.86 Reporting requirements.
- 585.87 Records.
- 585.88 Petition to extend period to file report.

Subpart J—Head Restraints Phase-in Reporting Requirements

- 585.91 Scope.
- 585.92 Purpose.
- 585.93 Applicability.
- 585.94 Definitions.
- 585.95 Response to inquiries.
- 585.96 Reporting requirements.
- 585.97 Records.

Subpart L—Roof Crush Resistance Phase-in Reporting Requirements

- 585.111 Scope.
- 585.112 Purpose.
- 585.113 Applicability.
- 585.114 Definitions.
- 585.115 Response to inquiries.
- 585.116 Reporting requirements.
- 585.117 Records.

AUTHORITY: 49 U.S.C. 322, 30111, 30115, 30117, and 30166; delegation of authority at 49 CFR 1.50.

SOURCE: 69 FR 70916, Dec. 8, 2004, unless otherwise noted.

Subpart A—General

§ 585.1 Definitions.

(a) All terms defined in 49 U.S.C. 30102 are used in accordance with their statutory meaning.

(b) The terms *bus*, *gross vehicle weight rating* or *GVWR*, *motor vehicle*, *multipurpose passenger vehicle*, *passenger car*, and *truck* are used as defined in §571.3 of this chapter.

(c) *Production year* means the 12-month period between September 1 of one year and August 31 of the following year, inclusive, unless otherwise specified.

§ 585.2 Phase-in reports.

Each report submitted to NHTSA under this part shall:

- (a) Identify the manufacturer;
- (b) State the full name, title, and address of the official responsible for preparing the report;
- (c) Identify the production year being reported on;
- (d) Contain a statement regarding whether or not the manufacturer complied with the requirements of the Federal motor vehicle safety standard addressed by the report, for the period covered by the report, and the basis for that statement;
- (e) Be written in the English language; and
- (f) Be submitted to: Administrator, National Highway Traffic Safety Administration, 400 Seventh Street, SW., Washington, DC 20590.

§ 585.3 Vehicles produced by more than one manufacturer.

Each manufacturer whose reporting of information is affected by one or more of the express written contracts permitted by a Federal Motor Vehicle Safety Standard subject to the reporting requirements of this part shall:

- (a) Report the existence of each contract, including the names of all parties to the contract and explain how the contract affects the report being submitted.
- (b) Report the number of vehicles covered by each contract in each production year.

§ 585.4 Petitions to extend period to file report.

A petition for extension of the time to submit a report required under this part shall be received not later than 15 days before the report is due. The petition shall be submitted to: Administrator, National Highway Traffic Safety Administration, 400 Seventh Street, SW., Washington, DC 20590. The filing of a petition does not automatically extend the time for filing a report. A petition will be granted only if the petitioner shows good cause for the extension, and if the extension is consistent with the public interest.

Subpart B—Advanced Air Bag Phase-in Reporting Requirements

§ 585.11 Scope.

This subpart establishes requirements for manufacturers of passenger cars and trucks, buses, and multipurpose passenger vehicles with a GVWR of 3,855 kg or less and an unloaded vehicle weight of 2,495 kg or less to submit reports, and maintain records related to the reports, concerning the number and identification of such vehicles that are certified as complying with the advanced air bag requirements of Standard No. 208, *Occupant crash protection* (49 CFR 571.208).

§ 585.12 Purpose.

The purpose of these reporting requirements is to aid the National Highway Traffic Safety Administration in determining whether a manufacturer has complied with the advanced air bag requirements of Standard No. 208 during the phase-ins of those requirements.

§ 585.13 Applicability.

This subpart applies to manufacturers of passenger cars and trucks, buses, and multipurpose passenger vehicles with a GVWR of 3,855 kg or less and an unloaded vehicle weight of 2,495 kg or less. However, this subpart does not apply to any manufacturers whose production consists exclusively of walk-in vans, vehicles designed to be sold exclusively to the U.S. Postal Service, vehicles manufactured in two or more stages, and vehicles that are altered

§ 585.14

after previously having been certified in accordance with part 567 of this chapter. In addition, this subpart does not apply to manufacturers whose production of motor vehicles for the United States market is less than 5,000 vehicles in a production year.

§ 585.14 Definitions.

For the purposes of this subpart,

(a) *Phase one of the advanced air bag requirements of Standard No. 208* refers to the requirements set forth in S14.1, S14.2, S14.5.1(a), S14.5.2, S15.1, S15.2, S17, S19, S21, S23, and S25 of Federal Motor Vehicle Safety Standard No. 208, 49 CFR 571.208.

(b) *Phase two of the advanced air bag reporting requirements of Standard No. 208* refers to the requirements set forth in S14.3, S14.4, S14.5.1(b), S14.5.2, S15.1, S15.2, S17, S19, S21, S23, and S25 of Federal Motor Vehicle Safety Standard No. 208, 49 CFR 571.208.

(c) *Phase three of the advanced air bag reporting requirements of Standard No. 208* refers to the requirements set forth in S14.6 and S14.7 of Federal Motor Vehicle Safety Standard No. 208, 49 CFR 571.208.

(d) *Vehicles* means passenger cars and trucks, buses, and multipurpose passenger vehicles with a GVWR of 3,855 kg or less and an unloaded vehicle weight of 2,495 kg or less manufactured for sale in the United States whose production of motor vehicles for sale in the United States is equal to or greater than 5,000 vehicles in a production year, and does not mean walk-in vans, vehicles designed to be sold exclusively to the U.S. Postal Service, vehicles manufactured in two or more stages, and vehicles that are altered after previously having been certified in accordance with part 567 of this chapter.

[69 FR 70916, Dec. 8, 2004, as amended at 71 FR 51779, Aug. 31, 2006]

§ 585.15 Reporting requirements.

(a) *Advanced credit phase-in reporting requirements.* (1) Within 60 days after the end of production years ending August 31, 2000, August 31, 2001, August 31, 2002, and August 31, 2003, each manufacturer choosing to certify vehicles manufactured during any of those production years as complying with phase one of the advanced air bag requirements of

49 CFR Ch. V (10–1–10 Edition)

Standard No. 208 shall submit a report to the National Highway Traffic Safety Administration providing the information specified in paragraph (c) of this section and in § 585.2 of this part.

(2) Within 60 days after the end of the production year ending August 31, 2007, each manufacturer choosing to certify vehicles manufactured during that production year as complying with phase two of the advanced air bag requirements of Standard No. 208 shall submit a report to the National Highway Traffic Safety Administration providing the information specified in paragraph (c) of this section and in § 585.2 of this part.

(3) Within 60 days after the end of the production year ending August 31, 2009, each manufacturer choosing to certify vehicles manufactured during that production year as complying with phase three of the advanced air bag requirements of Standard No. 208 shall submit a report to the National Highway Traffic Safety Administration providing the information specified in paragraph (c) of this section and in § 585.2 of this part.

(b) *Phase-in reporting requirements.* (1) Within 60 days after the end of the production years ending August 31, 2004, August 31, 2005, and August 31, 2006, each manufacturer shall submit a report to the National Highway Traffic Safety Administration regarding its compliance with phase one of the advanced air bag requirements of Standard No. 208 for its vehicles produced in that production year. The report shall provide the information specified in paragraph (d) of this section and in § 585.2 of this part. Each report shall also specify the number of advance credit vehicles, if any, which are being applied to the production year being reported on.

(2) Within 60 days after the end of production years ending August 31, 2008, August 31, 2009, and August 31, 2010, each manufacturer shall submit a report to the National Highway Traffic Safety Administration regarding its compliance with phase two of the advanced air bag requirements of Standard No. 208 for its vehicles produced in that production year. The report shall provide the information specified in paragraph (d) of this section and in

§ 585.2 of this part. Each report shall also specify the number of advance credit vehicles, if any, which are being applied to the production year being reported on.

(3) Within 60 days after the end of the production years ending August 31, 2010, August 31, 2011, and August 31, 2012, each manufacturer shall submit a report to the National Highway Traffic Safety Administration regarding its compliance with phase three of the advanced air bag requirements of Standard No. 208 for its vehicles produced in that production year. The report shall provide the information specified in paragraph (d) of this section and in § 585.2 of this part.

(c) *Advanced credit phase-in report content.* (1) With respect to the reports identified in section 585.15(a)(1), each manufacturer shall report for the production year for which the report is filed the number of vehicles, by make and model year, that meet the applicable advanced air bag requirements of Standard No. 208, and to which advanced air bag requirements the vehicles are certified.

(2) With respect to the report identified in section 585.15(a)(2), each manufacturer shall report the number of vehicles, by make and model year, that meet the applicable advanced air bag requirements of Standard No. 208, and to which the advanced air bag requirements the vehicles are certified.

(3) With respect to the report identified in section 585.15(a)(3), each manufacturer shall report the number of vehicles, by make and model year, that meet the applicable advanced air bag requirements of Standard No. 208, and to which the advanced air bag requirements the vehicles are certified.

(d) *Phase-in report content—(1) Basis for phase-in production requirements.* For production years ending August 31, 2003, August 31, 2004, August 31, 2005, August 31, 2007, August 31, 2008, August 31, 2009, August 31, 2010, and August 31, 2011, each manufacturer shall provide the number of vehicles manufactured in the current production year, or, at the manufacturer's option, for the current production year and each of the prior two production years if the manufacturer has manufactured vehicles during both of the two production

years prior to the year for which the report is being submitted.

(2) *Production of complying vehicles.* Each manufacturer shall report for the production year for which the report is filed the number of vehicles, by make and model year, that meet the applicable advanced air bag requirements of Standard No. 208, and to which advanced air bag requirements the vehicles are certified. Provide this information separately for phase two and phase three of the advanced air bag reporting requirements.

[69 FR 70916, Dec. 8, 2004, as amended at 71 FR 51779, Aug. 31, 2006; 72 FR 62142, Nov. 2, 2007]

§ 585.16 Records.

Each manufacturer shall maintain records of the Vehicle Identification Number of each vehicle for which information is reported under § 585.15(c) until December 31, 2011. Each manufacturer shall maintain records of the Vehicle Identification Number of each vehicle for which information is reported under § 585.15(d)(2) until December 31, 2013.

[72 FR 62142, Nov. 2, 2007]

Subpart C—Rear Inboard Lap/Shoulder Belt Phase-In Reporting Requirements

§ 585.21 Scope.

This subpart establishes requirements for manufacturers of passenger cars and for trucks, buses, and multi-purpose passenger vehicles with a GVWR of 4,536 kg (10,000 lb) or less to submit reports, and maintain records related to the reports, concerning the number and identification of such vehicles that are certified as complying with the Type 2 seat belt requirements for rear seating positions of Standard No. 208, *Occupant crash protection* (49 CFR 571.208).

§ 585.22 Purpose.

The purpose of these reporting requirements is to assist the National Highway Traffic Safety Administration in determining whether a manufacturer has complied with the Type 2 seat belt requirements for rear seating positions of Standard No. 208.

§ 585.23

§ 585.23 Applicability.

This subpart applies to manufacturers of passenger cars and trucks, buses, and multipurpose passenger vehicles with a GVWR of 4,536 kg or less. However, this subpart does not apply to any manufacturers whose production consists exclusively of walk-in vans, vehicles designed to be sold exclusively to the U.S. Postal Service, vehicles manufactured in two or more stages, and vehicles that are altered after previously having been certified in accordance with part 567 of this chapter. In addition, this subpart does not apply to manufacturers that produce fewer than 5,000 vehicles annually for sale in the United States.

[72 FR 62142, Nov. 2, 2007]

§ 585.24 Reporting requirements.

(a) *Advanced credit phase-in reporting requirements.* Within 60 days after the end of the production year ending August 31, 2005, each manufacturer choosing to certify vehicles manufactured during that production year as complying with the Type 2 seat belt for each rear designated seating position requirements of Standard No. 208 shall submit a report to the National Highway Traffic Safety Administration providing the information specified in paragraph (c) of this section and in § 585.2 of this part.

(b) *Phase-in reporting requirements.* Within 60 days after the end of the production years ending August 31, 2006, and August 31, 2007, each manufacturer shall submit a report to the National Highway Traffic Safety Administration regarding its compliance with the Type 2 seat belt for each rear designated seating position requirements of Standard No. 208 for its vehicles produced in that production year. The report shall provide the information specified in paragraph (d) of this section and in § 585.2 of this part. Each report shall also specify the number of advance credit vehicles, if any, which are being applied to the production year being reported on.

(c) *Advanced credit phase-in report content.* With respect to the reports identified in section 585.24(a), each manufacturer shall report for the production year for which the report is filed the

49 CFR Ch. V (10–1–10 Edition)

number of vehicles, by make and model year, that meet the applicable Type 2 seat belt for each rear designated seating position requirements of Standard No. 208.

(d) *Phase-in report content.* (1) Basis for phase-in production requirements. For production years ending August 31, 2006, and August 31, 2007, each manufacturer shall provide the number of vehicles manufactured in the current production year, or, at the manufacturer's option, for the current production year and each of the prior two production years if the manufacturer has manufactured vehicles during each production year prior to the year for which the report is being submitted.

(2) Production of complying vehicles. Each manufacturer shall report for the production year for which the report is filed the number of vehicles, by make and model year, that meet the applicable Type 2 seat belt for each rear designated seating position requirements of Standard No. 208.

§ 585.25 Records.

Each manufacturer shall maintain records of the Vehicle Identification Number of each vehicle for which information is reported under § 585.24(c) and (d)(2) until December 31, 2008.

Subpart D—Appendix A–1 of FMVSS No. 208 Phase-in Reporting Requirements

SOURCE: 73 FR 66801, Nov. 12, 2008, unless otherwise noted.

§ 585.31 Scope.

This part establishes requirements for manufacturers of passenger cars, and of trucks, buses and multipurpose passenger vehicles with a gross vehicle weight rating (GVWR) of 3,856 kilograms (kg) (8,500 pounds (lb)) or less, to submit a report, and maintain records related to the report, concerning the number of such vehicles that are certified as complying with S19, S21, and S23 of FMVSS No. 208 (49 CFR 571.208) when using the child restraint systems specified in Appendix A–1 of this standard.

§ 585.32 Purpose.

The purpose of these reporting requirements is to assist the National Highway Traffic Safety Administration in determining whether a manufacturer has complied with the requirements of Standard No. 208 when using the child restraint systems specified in Appendix A-1 of that standard.

§ 585.33 Applicability.

This part applies to manufacturers of passenger cars, and of trucks, buses and multipurpose passenger vehicles with a GVWR of 3,856 kg (8,500 lb) or less.

§ 585.34 Definitions.

(a) All terms defined in 49 U.S.C. 30102 are used in their statutory meaning.

(b) Bus, gross vehicle weight rating or GVWR, multipurpose passenger vehicle, passenger car, and truck are used as defined in § 571.3 of this chapter.

(c) Production year means the 12-month period between September 1 of one year and August 31 of the following year, inclusive.

(d) Limited line manufacturer means a manufacturer that sells three or fewer carlines, as that term is defined in 49 CFR 583.4, in the United States during a production year.

§ 585.35 Response to inquiries.

At any time during the production year ending August 31, 2010, each manufacturer shall, upon request from the Office of Vehicle Safety Compliance, provide information identifying the vehicles (by make, model and vehicle identification number) that have been certified as complying with the requirements of Standard No. 208 when using the child restraint systems specified in Appendix A-1 of that standard. The manufacturer's designation of a vehicle as a certified vehicle is irrevocable.

§ 585.36 Reporting Requirements.

(a) *Phase-in reporting requirements.* Within 60 days after the end of the production year ending August 31, 2010, each manufacturer shall submit a report to the National Highway Traffic Safety Administration concerning its

compliance with requirements of Standard No. 208 when using the child restraint systems specified in Appendix A-1 of that standard for its vehicles produced in that year. Each report shall provide the information specified in paragraph (b) of this section and in section 585.2 of this part.

(b) *Phase-in report content—*

(1) *Basis for phase-in production goals.* Each manufacturer shall provide the number of vehicles manufactured in the current production year, or, at the manufacturer's option, in each of the three previous production years. A new manufacturer that is, for the first time, manufacturing passenger cars, trucks, multipurpose passenger vehicles or buses for sale in the United States must report the number of passenger cars, trucks, multipurpose passenger vehicles or buses manufactured during the current production year.

(2) *Production of complying vehicles.* Each manufacturer shall report on the number of vehicles that meet the requirements of Standard No. 208 when using the child restraint systems specified in Appendix A-1 of that standard.

§ 585.37 Records.

Each manufacturer shall maintain records of the Vehicle Identification Number for each vehicle for which information is reported under § 585.36 until December 31, 2013.

Subpart E—Fuel System Integrity Phase-In Reporting Requirements

§ 585.41 Scope.

This subpart establishes requirements for manufacturers of passenger cars, multipurpose passenger vehicles, trucks, and buses with a GVWR of 4,536 kg (10,000 lb) or less to respond to NHTSA inquiries, to submit reports, and to maintain records related to the reports, concerning the number of such vehicles that meet the upgraded requirements of Standard No. 301, *Fuel systems integrity* (49 CFR 571.301).

§ 585.42 Purpose.

The purpose of these requirements is to assist the National Highway Traffic Safety Administration in determining whether a manufacturer has complied

§ 585.43

with the upgraded requirements of Standard No. 301.

§ 585.43 Applicability.

This subpart applies to manufacturers of passenger cars, multipurpose passenger vehicles, trucks and buses with a GVWR of 4,536 or less. However, this subpart does not apply to manufacturers that produce fewer than 5,000 vehicles annually for sale in the United States.

[72 FR 62142, Nov. 2, 2007]

§ 585.44 Response to inquiries.

During the production years ending August 31, 2007, August 31, 2008, and August 31, 2009, each manufacturer shall, upon request from the Office of Vehicle Safety Compliance, provide information identifying the vehicles (by make, model, and vehicle identification number) that have been certified as complying with the requirements of § 6.2(b) of Standard No. 301. The manufacturer's designation of a vehicle as a certified vehicle is irrevocable.

§ 585.45 Reporting requirements.

(a) *General reporting requirements.* Within 60 days after the end of the production years ending August 31, 2007, August 31, 2008 and August 31, 2009, each manufacturer shall submit a report to the National Highway Traffic Safety Administration concerning its compliance with § 6.2(b) of Standard No. 301 for its passenger cars, multipurpose passenger vehicles, trucks, and buses with a GVWR of less than 4,536 kg produced in that year. Each report shall provide the information specified in paragraph (b) of this section and in section 585.2 of this part.

(b) *Report content.* (1) Basis for statement of compliance. Each manufacturer shall provide the number of passenger cars, multipurpose passenger vehicles, trucks, and buses with a GVWR of 4,536 kg or less manufactured for sale in the United States for each of the three previous production years, or, at the manufacturer's option, for the previous production year. A new manufacturer that has not previously manufactured these vehicles for sale in the United States must report the

49 CFR Ch. V (10–1–10 Edition)

number of such vehicles manufactured during the current production year.

(2) Production. Each manufacturer shall report for the production year for which the report is filed the number of passenger cars, multipurpose passenger vehicles, trucks, and buses with a GVWR of 4,536 kg or less that meet § 6.2(b) or § 6.3(b) of Standard No. 301.

§ 585.46 Records.

Each manufacturer shall maintain records of the Vehicle Identification Number for each vehicle for which information is reported under § 585.45(b)(2) until December 31, 2010.

Subpart F—Tires for Motor Vehicles with a GVWR of 10,000 Pounds or Less Phase-In Reporting Requirements

§ 585.51 Scope.

This subpart establishes requirements for manufacturers of new pneumatic tires for motor vehicles with a GVWR of 4,536 kg (10,000 lb) or less to respond to NHTSA inquiries, to submit reports, and to maintain records related to the reports, concerning the number of such tires that meet the requirements of Standard No. 139, *New pneumatic tires for light vehicles* (49 CFR 571.139).

§ 585.52 Purpose.

The purpose of these requirements is to assist the National Highway Traffic Safety Administration in determining whether a manufacturer has complied with the requirements of Standard No. 139.

§ 585.53 Applicability.

This subpart applies to manufacturers of tires for motor vehicles with a GVWR of 4,536 kg or less.

§ 585.54 Response to inquiries.

Each manufacturer shall, upon request from the Office of Vehicle Safety Compliance, provide information identifying the tires (by make, model, brand and tire identification number) that have been certified as complying with the requirements of Standard No. 139. The manufacturer's designation of a tire as a certified tire is irrevocable.

§ 585.55 Reporting requirements.

(a) *General reporting requirements.* Within 60 days after the end of the production years ending August 31, 2006 and August 31, 2007, each manufacturer shall submit a report to the National Highway Traffic Safety Administration concerning its compliance with Standard No. 139 for its tires produced in that year for motor vehicles with a GVWR of 4,536 kg or less. Each report shall provide the information specified in paragraph (b) of this section and in section 585.2 of this part.

(b) *Report content.* (1) Basis for statement of compliance. Each manufacturer shall provide the number of tires for motor vehicles with a GVWR of 4,536 kg or less manufactured for sale in the United States for each of the three previous production years, or, at the manufacturer's option, for the production year for which the report is filed. A new manufacturer that has not previously manufactured these tires for sale in the United States shall report the number of such tires manufactured during the current production year.

(2) Production. Each manufacturer shall report for the production year for which the report is filed the number of new pneumatic tires for motor vehicles with a GVWR of 4,536 kg or less that meet Standard No. 139.

§ 585.56 Records.

Each manufacturer shall maintain records of the tire identification number for each vehicle for which information is reported under § 585.55(b)(2) until December 31, 2008.

Subpart G—Tire Pressure Monitoring System Phase-in Reporting Requirements

SOURCE: 70 FR 18190, Apr. 8, 2005, unless otherwise noted.

§ 585.61 Scope.

This subpart establishes requirements for manufacturers of passenger cars, multipurpose passenger vehicles, trucks, and buses with a gross vehicle weight rating of 4,536 kilograms (10,000 pounds) or less, except those vehicles with dual wheels on an axle, to submit a report, and maintain records related

to the report, concerning the number of such vehicles that meet the requirements of Standard No. 138, *Tire pressure monitoring systems* (49 CFR 571.138).

§ 585.62 Purpose.

The purpose of these reporting requirements is to assist the National Highway Traffic Safety Administration in determining whether a manufacturer has complied with Standard No. 138.

§ 585.63 Applicability.

This subpart applies to manufacturers of passenger cars, multipurpose passenger vehicles, trucks, and buses with a gross vehicle weight rating of 4,536 kilograms (10,000 pounds) or less, except those vehicles with dual wheels on an axle. However, this subpart does not apply to manufacturers whose production consists exclusively of vehicles manufactured in two or more stages, and vehicles that are altered after previously having been certified in accordance with part 567 of the chapter. In addition, this subpart does not apply to manufacturers whose production of motor vehicles for the United States market is less than 5,000 vehicles in a production year.

§ 585.64 Definitions.

Production year means the 12-month period between September 1 of one year and August 31 of the following year, inclusive.

§ 585.65 Response to inquiries.

At any time prior to August 31, 2007, each manufacturer must, upon request from the Office of Vehicle Safety Compliance, provide information identifying the vehicles (by make, model, and vehicle identification number) that have been certified as complying with Standard No. 138. The manufacturer's designation of a vehicle as a certified vehicle is irrevocable. Upon request, the manufacturer also must specify whether it intends to utilize either carry-forward or carry-backward credits, and the vehicles to which those credits relate.

§ 585.66 Reporting requirements.

(a) *General reporting requirements.* Within 60 days after the end of the production years ending August 31, 2006 and August 31, 2007, each manufacturer must submit a report to the National Highway Traffic Safety Administration concerning its compliance with Standard No. 138 (49 CFR 571.138) for its passenger cars, multipurpose passenger vehicles, trucks, and buses with a gross vehicle weight rating of less than 4,536 kilograms (10,000 pounds) produced in that year. Each report must—

- (1) Identify the manufacturer;
- (2) State the full name, title, and address of the official responsible for preparing the report;
- (3) Identify the production year being reported on;
- (4) Contain a statement regarding whether or not the manufacturer complied with the requirements of Standard No. 138 (49 CFR 571.138) for the period covered by the report and the basis for that statement;
- (5) Provide the information specified in paragraph (b) of this section;
- (6) Be written in the English language; and
- (7) Be submitted to: Administrator, National Highway Traffic Safety Administration, 400 Seventh Street, SW., Washington, DC 20590.

(b) *Report content*—(1) *Basis for statement of compliance.* Each manufacturer must provide the number of passenger cars, multipurpose passenger vehicles, trucks, and buses with a gross vehicle weight rating of 4,536 kilograms (10,000 pounds) or less, except those vehicles with dual wheels on an axle, manufactured for sale in the United States for each reporting period as follows:

- (i) *Period from October 5, 2005 to August 31, 2006.* The number shall be either the manufacturer's average annual production of vehicles manufactured on or after September 1, 2002, and before October 5, 2005, or, at the manufacturer's option, it shall be the manufacturer's production on or after October 5, 2005 and before September 1, 2006. A new manufacturer that has not previously manufactured these vehicles for sale in the United States must report the number of such vehicles manufactured during the production period

on or after October 5, 2005 and before September 1, 2006.

- (ii) *Period from September 1, 2006 to August 31, 2007.* The number shall be either the manufacturer's average annual production of vehicles manufactured on or after September 1, 2003, and before September 1, 2006, or, at the manufacturer's option, it shall be the manufacturer's production on or after September 1, 2006 and before September 1, 2007. A new manufacturer that has not previously manufactured these vehicles for sale in the United States must report the number of such vehicles manufactured during the production period on or after September 1, 2006 and before September 1, 2007.

(2) *Production.* Each manufacturer must report for the production period for which the report is filed: the total number of passenger cars, multipurpose passenger vehicles, trucks, and buses with a gross vehicle weight rating of 4,536 kilograms (10,000 pounds) or less that meet Standard No. 138 (49 CFR 571.138).

(3) *Statement regarding compliance.* Each manufacturer must provide a statement regarding whether or not the manufacturer complied with the TPMS requirements as applicable to the period covered by the report, and the basis for that statement. This statement must include an explanation concerning the use of any carry-forward and/or carry-backward credits.

(4) *Vehicles produced by more than one manufacturer.* Each manufacturer whose reporting of information is affected by one or more of the express written contracts permitted by S7.5.2 of Standard No. 138 (49 CFR 571.138) must:

- (i) Report the existence of each contract, including the names of all parties to the contract, and explain how the contract affects the report being submitted.
- (ii) Report the actual number of vehicles covered by each contract.

[70 FR 18190, Apr. 8, 2005, as amended at 70 FR 53101, Sept. 7, 2005]

§ 585.67 Records.

Each manufacturer must maintain records of the Vehicle Identification

Number for each vehicle for which information is reported under § 585.66(b)(2) until December 31, 2009.

§ 585.68 Petition to extend period to file report.

A manufacturer may petition for extension of time to submit a report under this Part. A petition will be granted only if the petitioner shows good cause for the extension and if the extension is consistent with the public interest. The petition must be received not later than 15 days before expiration of the time stated in § 585.66(a). The filing of a petition does not automatically extend the time for filing a report. The petition must be submitted to: Administrator, National Highway Traffic Safety Administration, 400 Seventh Street, SW., Washington, DC 20590.

Subpart H—Side Impact Protection Phase-in Reporting Requirements

SOURCE: 72 FR 51972, Sept. 11, 2007, unless otherwise noted.

§ 585.71 Scope.

This part establishes requirements for manufacturers of passenger cars, and of trucks, buses and multipurpose passenger vehicles with a gross vehicle weight rating (GVWR) of 4,536 kilograms (kg) (10,000 pounds) or less, to submit a report, and maintain records related to the report, concerning the number of such vehicles that meet the moving deformable barrier test requirements of S7 of Standard No. 214, *Side impact protection* (49 CFR 571.214), and the vehicle-to-pole test requirements of S9 of that standard.

§ 585.72 Purpose.

The purpose of these reporting requirements is to assist the National Highway Traffic Safety Administration in determining whether a manufacturer has complied with the requirements of Standard No. 214, *Side Impact Protection* (49 CFR 571.214).

§ 585.73 Applicability.

This part applies to manufacturers of passenger cars, and of trucks, buses

and multipurpose passenger vehicles with a GVWR of 4,536 kg (10,000 lb) or less. However, this part does not apply to vehicles excluded by S2 and S5 of Standard No. 214 (49 CFR 571.214) from the requirements of that standard.

§ 585.74 Definitions.

(a) All terms defined in 49 U.S.C. 30102 are used in their statutory meaning.

(b) *Bus, gross vehicle weight rating or GVWR, multipurpose passenger vehicle, passenger car, and truck* are used as defined in § 571.3 of this chapter.

(c) *Production year* means the 12-month period between September 1 of one year and August 31 of the following year, inclusive.

(d) *Limited line manufacturer* means a manufacturer that sells three or fewer carlines, as that term is defined in 49 CFR 583.4, in the United States during a production year.

§ 585.75 Response to inquiries.

At any time during the production years ending August 31, 2011, August 31, 2012, August 31, 2013, and August 31, 2014, each manufacturer shall, upon request from the Office of Vehicle Safety Compliance, provide information identifying the vehicles (by make, model and vehicle identification number) that have been certified as complying with the moving deformable barrier test with advanced test dummies (S7.2) or the vehicles (by make, model and vehicle identification number) that have been certified as complying with the vehicle-to-pole test requirements (S9.1) of FMVSS No. 214 (49 CFR 571.214). The manufacturer's designation of a vehicle as a certified vehicle that meets S7.2 or S9.1 is irrevocable.

[73 FR 32485, June 9, 2008]

§ 585.76 Reporting requirements.

(a) *Advanced credit phase-in reporting requirements.* (1) Within 60 days after the end of the production years ending August 31, 2008, through August 31, 2014, each manufacturer choosing to certify vehicles manufactured during any of those production years as complying with the upgraded moving deformable barrier (S7.2 of Standard No. 214)(49 CFR 571.214) or vehicle-to-pole

§ 585.77

requirements (S9) of Standard No. 214 shall submit a report to the National Highway Traffic Safety Administration providing the information specified in paragraph (c) of this section and in § 585.2 of this part.

(2) [Reserved]

(b) *Phase-in reporting requirements.* Within 60 days after the end of each of the production years ending August 31, 2011, August 31, 2012, August 31, 2013, and August 31, 2014, each manufacturer shall submit a report to the National Highway Traffic Safety Administration concerning its compliance with the moving deformable barrier requirements of S7 of Standard No. 214 and with the vehicle-to-pole requirements of S9 of that Standard for its vehicles produced in that year. Each report shall provide the information specified in paragraph (c) of this section and in section 585.2 of this part.

(c) *Advanced credit phase-in report content—(1) Production of complying vehicles.* With respect to the reports identified in § 585.76(a), each manufacturer shall report for the production year for which the report is filed the number of vehicles, by make and model year: That are certified as meeting the moving deformable barrier test requirements of S7.2 of Standard No. 214, *Side impact protection* (49 CFR 571.214), and that are certified as meeting the vehicle-to-pole test requirements of S9 of Standard No. 214.

(2) [Reserved]

(d) *Phase-in report content—(1) Basis for phase-in production goals.* Each manufacturer shall provide the number of vehicles manufactured in the current production year, or, at the manufacturer's option, in each of the three previous production years. A new manufacturer that is, for the first time, manufacturing passenger cars for sale in the United States must report the number of passenger cars manufactured during the current production year.

(2) *Production of complying vehicles.* Each manufacturer shall report for the production year being reported on, and each preceding production year, to the extent that vehicles produced during the preceding years are treated under Standard No. 214 as having been produced during the production year being

49 CFR Ch. V (10–1–10 Edition)

reported on, information on the number of vehicles that meet the moving deformable barrier test requirements of S7 of Standard No. 214, *Side Impact Protection* (49 CFR 571.214), and the number of vehicles that meet the vehicle-to-pole test requirements of S9 of that standard.

[72 FR 51972, Sept. 11, 2007, as amended at 73 FR 32485, June 9, 2008]

§ 585.77 Records.

Each manufacturer shall maintain records of the Vehicle Identification Number for each vehicle for which information is reported under § 585.76 until December 31, 2018.

[73 FR 32485, June 9, 2008]

Subpart I—Electronic Stability Control System Phase-In Reporting Requirements

SOURCE: 72 FR 17316, Apr. 6, 2007, unless otherwise noted.

§ 585.81 Scope.

This subpart establishes requirements for manufacturers of passenger cars, multipurpose passenger vehicles, trucks, and buses with a gross vehicle weight rating of 4,536 kilograms (10,000 pounds) or less to submit a report, and maintain records related to the report, concerning the number of such vehicles that meet the requirements of Standard No. 126, *Electronic stability control systems* (49 CFR 571.126).

§ 585.82 Purpose.

The purpose of these reporting requirements is to assist the National Highway Traffic Safety Administration in determining whether a manufacturer has complied with Standard No. 126 (49 CFR 571.126).

§ 585.83 Applicability.

This subpart applies to manufacturers of passenger cars, multipurpose passenger vehicles, trucks, and buses with a gross vehicle weight rating of 4,536 kilograms (10,000 pounds) or less. However, this subpart does not apply to manufacturers whose production

consists exclusively of vehicles manufactured in two or more stages, and vehicles that are altered after previously having been certified in accordance with part 567 of this chapter. In addition, this subpart does not apply to manufacturers whose production of motor vehicles for the United States market is less than 5,000 vehicles in a production year.

§ 585.84 Definitions.

For the purposes of this subpart:

Production year means the 12-month period between September 1 of one year and August 31 of the following year, inclusive.

§ 585.85 Response to inquiries.

At any time prior to August 31, 2011, each manufacturer must, upon request from the Office of Vehicle Safety Compliance, provide information identifying the vehicles (by make, model, and vehicle identification number) that have been certified as complying with Standard No. 126 (49 CFR 571.126). The manufacturer's designation of a vehicle as a certified vehicle is irrevocable. Upon request, the manufacturer also must specify whether it intends to utilize carry-forward credits, and the vehicles to which those credits relate.

§ 585.86 Reporting requirements.

(a) *General reporting requirements.* Within 60 days after the end of the production years ending August 31, 2009, August 31, 2010, and August 31, 2011, each manufacturer must submit a report to the National Highway Traffic Safety Administration concerning its compliance with Standard No. 126 (49 CFR 571.126) for its passenger cars, multipurpose passenger vehicles, trucks, and buses with a gross vehicle weight rating of less than 4,536 kilograms (10,000 pounds) produced in that year. Each report must—

- (1) Identify the manufacturer;
- (2) State the full name, title, and address of the official responsible for preparing the report;
- (3) Identify the production year being reported on;
- (4) Contain a statement regarding whether or not the manufacturer complied with the requirements of Standard No. 126 (49 CFR 571.126) for the pe-

riod covered by the report and the basis for that statement;

(5) Provide the information specified in paragraph (b) of this section;

(6) Be written in the English language; and

(7) Be submitted to: Administrator, National Highway Traffic Safety Administration, 400 Seventh Street, SW., Washington, DC 20590.

(b) *Report content*—(1) *Basis for statement of compliance.* Each manufacturer must provide the number of passenger cars, multipurpose passenger vehicles, trucks, and buses with a gross vehicle weight rating of 4,536 kilograms (10,000 pounds) or less, manufactured for sale in the United States for each of the three previous production years, or, at the manufacturer's option, for the current production year. A new manufacturer that has not previously manufactured these vehicles for sale in the United States must report the number of such vehicles manufactured during the current production year.

(2) *Production.* Each manufacturer must report for the production year for which the report is filed: the number of passenger cars, multipurpose passenger vehicles, trucks, and buses with a gross vehicle weight rating of 4,536 kilograms (10,000 pounds) or less that meet Standard No. 126 (49 CFR 571.126).

(3) *Statement regarding compliance.* Each manufacturer must provide a statement regarding whether or not the manufacturer complied with the ESC requirements as applicable to the period covered by the report, and the basis for that statement. This statement must include an explanation concerning the use of any carry-forward credits.

(4) *Vehicles produced by more than one manufacturer.* Each manufacturer whose reporting of information is affected by one or more of the express written contracts permitted by S8.6.2 of Standard No. 126 (49 CFR 571.126) must:

(i) Report the existence of each contract, including the names of all parties to the contract, and explain how the contract affects the report being submitted.

(ii) Report the actual number of vehicles covered by each contract.

§ 585.87**§ 585.87 Records.**

Each manufacturer must maintain records of the Vehicle Identification Number for each vehicle for which information is reported under § 585.86(b)(2) until December 31, 2013.

§ 585.88 Petition to extend period to file report.

A manufacturer may petition for extension of time to submit a report under this Part. A petition will be granted only if the petitioner shows good cause for the extension and if the extension is consistent with the public interest. The petition must be received not later than 15 days before expiration of the time stated in § 585.86(a). The filing of a petition does not automatically extend the time for filing a report. The petition must be submitted to: Administrator, National Highway Traffic Safety Administration, 400 Seventh Street, SW., Washington, DC 20590.

Subpart J—Head Restraints Phase-in Reporting Requirements

SOURCE: 72 FR 25523, May 4, 2007, unless otherwise noted.

§ 585.91 Scope.

This subpart establishes requirements for manufacturers of passenger cars, multipurpose passenger vehicles, trucks and buses with a GVWR of 4,536 kg or less to submit a report, and maintain records related to the report, concerning the number of vehicles that meet the requirements of Standard No. 202a.

§ 585.92 Purpose.

The purpose of these reporting requirements is to assist the National Highway Traffic Safety Administration in determining whether a manufacturer has complied with Standard No. 202a.

§ 585.93 Applicability.

This subpart applies to manufacturers of passenger cars, multipurpose passenger vehicles, trucks and buses with a GVWR of 4,536 kg or less. However, it does not apply to manufacturers whose production consists exclu-

sively of vehicles that are manufactured in two or more stages or that are altered (within the meaning of 49 CFR 567.7) after having previously been certified in accordance with part 567 of this chapter.

§ 585.94 Definitions.

Production year means the 12-month period between September 1 of one year and August 31 of the following year, inclusive.

§ 585.95 Response to inquiries.

(a) *Production year ending August 31, 2010.* At any time during the production year, each manufacturer must, upon request from the Office of Vehicle Safety Compliance, provide information identifying the vehicles (by make, model and vehicle identification number) that have been certified as complying with § 571.202a without regard to any option to comply with the standard in § 571.202 or with the European regulations referenced in S4.3(a) of § 571.202.

(b) *Production year ending August 31, 2011.* At any time during the production year, each manufacturer must, upon request from the Office of Vehicle Safety Compliance, provide information identifying the vehicles (by make, model and vehicle identification number) that have been certified as complying with the requirements specified in § 571.202a for rear head restraints.

§ 585.96 Reporting requirements.

(a) *Production year ending August 31, 2010—(1) General reporting requirements.* Within 60 days after the end of the production year ending August 31, 2010, each manufacturer must submit a report to the National Highway Traffic Safety Administration concerning its compliance with the head restraint requirements specified in § 571.202a, without regard to any option to comply with the standard in § 571.202 or with the European regulations referenced in S4.3(a) of § 571.202, for its passenger cars, trucks, buses and multipurpose passenger vehicles produced in that year. The report must provide the information specified in paragraph (2) of this section and in § 585.2 of this part.

(2) *Report content—(i) Basis for phase-in production goals.* Each manufacturer

must provide the number of passenger cars and multipurpose passenger vehicles, trucks and buses with a GVWR of 4,536 kg or less manufactured for sale in the United States. The number must be either the manufacturer's average annual production of vehicles manufactured on or after September 1, 2007 and before September 1, 2010, or, at the manufacturer's option, the manufacturer's production on or after September 1, 2009 and before September 1, 2010. A new manufacturer that has not previously manufactured these vehicles for sale in the United States must report the number of such vehicles manufactured during the production period beginning on or after September 1, 2009 and before September 1, 2010.

(ii) *Production.* Each manufacturer must report for the production year ending August 31, 2010: The total number of passenger cars, multipurpose passenger vehicles, trucks, and buses with a gross vehicle weight rating of 4,536 kg or less that meet § 571.202a, without regard to any option to comply with the standard in § 571.202 or with the European regulations referenced in S4.3(a) of § 571.202.

(b) *Production year ending August 31, 2011—(1) General reporting requirements.* Within 60 days after the end of the production year ending August 31, 2011, each manufacturer must submit a report to the National Highway Traffic Safety Administration concerning its compliance with the rear head restraint requirements specified in § 571.202a. The report must provide the information specified in paragraph (2) of this section and in § 585.2 of this part.

(2) *Report content—(i) Basis for phase-in production goals.* Each manufacturer must provide the number of passenger cars and multipurpose passenger vehicles, trucks and buses with a GVWR of 4,536 kg or less manufactured for sale in the United States with rear head restraints. The number must be either the manufacturer's average annual production of vehicles with rear head restraints manufactured on or after September 1, 2008 and before September 1, 2011, or, at the manufacturer's option, the manufacturer's production on or after September 1, 2010 and before September 1, 2011. A new manufacturer

that has not previously manufactured these vehicles for sale in the United States must report the number of such vehicles manufactured during the production period on or after September 1, 2010 and before September 1, 2011.

(ii) *Production.* Each manufacturer must report for the production year ending August 31, 2011: The total number of passenger cars, multipurpose passenger vehicles, trucks, and buses with a gross vehicle weight rating of 4,536 kg or less that meet the rear head restraint requirements of § 571.202a.

§ 585.97 Records.

Each manufacturer must maintain records of the Vehicle Identification Number for each vehicle for which information is reported under § 585.96 until December 31, 2007.

Subpart L—Roof Crush Resistance Phase-in Reporting Requirements

SOURCE: 74 FR 22387, May 12, 2009, unless otherwise noted.

§ 585.111 Scope.

This subpart establishes requirements for manufacturers of passenger cars, multipurpose passenger vehicles, trucks, and buses with a gross vehicle weight rating of 2,722 kilograms (6,000 pounds) or less to submit a report, and maintain records related to the report, concerning the number of such vehicles that meet the requirements of Standard No. 216a; *Roof crush resistance; Upgraded standard* (49 CFR 571.216a).

§ 585.112 Purpose.

The purpose of these reporting requirements is to assist the National Highway Traffic Safety Administration in determining whether a manufacturer has complied with Standard No. 216a (49 CFR 571.216a).

§ 585.113 Applicability.

This subpart applies to manufacturers of passenger cars, multipurpose passenger vehicles, trucks, and buses with a gross vehicle weight rating of 2,722 kilograms (6,000 pounds) or less. However, this subpart does not apply to manufacturers whose production

§ 585.114

consists exclusively of vehicles manufactured in two or more stages, and vehicles that are altered after previously having been certified in accordance with part 567 of this chapter. In addition, this subpart does not apply to manufacturers whose production of motor vehicles for the United States market is less than 5,000 vehicles in a production year.

§ 585.114 Definitions.

For the purposes of this subpart:

Production year means the 12-month period between September 1 of one year and August 31 of the following year, inclusive.

§ 585.115 Response to inquiries.

At any time prior to August 31, 2018, each manufacturer must, upon request from the Office of Vehicle Safety Compliance, provide information identifying the vehicles (by make, model, and vehicle identification number) that have been certified as complying with Standard No. 216a (49 CFR 571.216a). The manufacturer's designation of a vehicle as a certified vehicle is irrevocable. Upon request, the manufacturer also must specify whether it intends to utilize carry-forward credits, and the vehicles to which those credits relate.

§ 585.116 Reporting requirements.

(a) *General reporting requirements.* Within 60 days after the end of the production years ending August 31, 2013, August 31, 2014, and August 31, 2015, each manufacturer must submit a report to the National Highway Traffic Safety Administration concerning its compliance with Standard No. 216a (49 CFR 571.216a) for its passenger cars, multipurpose passenger vehicles, trucks, and buses with a gross vehicle weight rating of less than 2,722 kilograms (6,000 pounds) produced in that year. Each report must —

(1) Identify the manufacturer;

(2) State the full name, title, and address of the official responsible for preparing the report;

(3) Identify the production year being reported on;

(4) Contain a statement regarding whether or not the manufacturer complied with the requirements of Standard No. 216a (49 CFR 571.216a) for the

49 CFR Ch. V (10–1–10 Edition)

period covered by the report and the basis for that statement;

(5) Provide the information specified in paragraph (b) of this section;

(6) Be written in the English language; and

(7) Be submitted to: Administrator, National Highway Traffic Safety Administration, 1200 New Jersey Avenue, SE., Washington, DC 20590.

(b) *Report content*—(1) *Basis for statement of compliance.* Each manufacturer must provide the number of passenger cars, multipurpose passenger vehicles, trucks, and buses with a gross vehicle weight rating of 2,722 kilograms (6,000 pounds) or less, manufactured for sale in the United States for each of the three previous production years, or, at the manufacturer's option, for the current production year. A new manufacturer that has not previously manufactured these vehicles for sale in the United States must report the number of such vehicles manufactured during the current production year.

(2) *Production.* Each manufacturer must report for the production year for which the report is filed: the number of passenger cars, multipurpose passenger vehicles, trucks, and buses with a gross vehicle weight rating of 2,722 kilograms (6,000 pounds) or less that meet Standard No. 216a (49 CFR 571.216a).

(3) *Statement regarding compliance.* Each manufacturer must provide a statement regarding whether or not the manufacturer complied with the requirements of Standard No. 216a (49 CFR 571.216a) as applicable to the period covered by the report, and the basis for that statement. This statement must include an explanation concerning the use of any carry-forward credits.

(4) *Vehicles produced by more than one manufacturer.* Each manufacturer whose reporting of information is affected by one or more of the express written contracts permitted by S8.6.2 of Standard No. 216a (49 CFR 571.216a) must:

(i) Report the existence of each contract, including the names of all parties to the contract, and explain how the contract affects the report being submitted.

(ii) Report the actual number of vehicles covered by each contract.

§ 585.117 Records.

Each manufacturer must maintain records of the Vehicle Identification Number for each vehicle for which information is reported under § 585.116(b)(2) until December 31, 2018.

PART 586 [RESERVED]

PART 587—DEFORMABLE BARRIERS

Subpart A—General

- Sec.
- 587.1 Scope.
- 587.2 Purpose.
- 587.3 Application.

Subpart B—Side Impact Moving Deformable Barrier

- 587.4 Definitions.
- 587.5 Incorporated materials.
- 587.6 General description.
- 587.7–587.10 [Reserved]

Subpart C—Offset Deformable Barrier

- 587.11 [Reserved]
- 587.12 Incorporation by reference.
- 587.13 General description.
- 587.14 Deformable face component dimensions and material specifications.
- 587.15 Verification of aluminum honeycomb crush strength.
- 587.16 Adhesive bonding procedure.
- 587.17 Construction.
- 587.18 Dimensions of fixed rigid barrier.
- 587.19 Mounting.

FIGURES TO SUBPART C

AUTHORITY: 49 U.S.C. 322, 30111, 30115, 30117, and 30166; delegation of authority at 49 CFR 1.50.

SOURCE: 55 FR 45779, Oct. 30, 1990, unless otherwise noted.

EDITORIAL NOTE: Nomenclature changes to part 587 appear at 69 FR 18803, Apr. 9, 2004.

Subpart A—General

§ 587.1 Scope.

This part describes deformable impact barriers that are to be used for testing compliance of motor vehicles with motor vehicle safety standards.

[65 FR 17198, Mar. 31, 2000]

§ 587.2 Purpose.

The design and performance criteria specified in this part are intended to describe measuring tools with suffi-

cient precision to give repetitive and correlative results under similar test conditions and to reflect adequately the protective performance of a motor vehicle or item of motor vehicle equipment with respect to human occupants

§ 587.3 Application.

This part does not in itself impose duties or liabilities on any person. It is a description of tools that are used in compliance tests to measure the performance of occupant protection systems required by the safety standards that refer to these tools. It is designed to be referenced by, and become part of, the test procedures specified in motor vehicle safety standards such as Standard No. 208, *Occupant Crash Protection*, and Standard No. 214, *Side Impact Protection*.

[65 FR 17199, Mar. 31, 2000]

Subpart B—Side Impact Moving Deformable Barrier

§ 587.4 Definitions.

All terms defined in section 102 of the National Traffic and Motor Vehicle Safety Act (15 U.S.C. 1391) are used in their statutory meaning.

§ 587.5 Incorporated materials.

(a) The drawings and specifications referred to in this regulation that are not set forth in full are hereby incorporated in this part by reference. These materials are thereby made part of this regulation. The Director of the Federal Register has approved the materials incorporated by reference. For materials subject to change, only the specific version approved by the Director of the Federal Register and specified in the regulation are incorporated. A notice of any change will be published in the FEDERAL REGISTER. As a convenience to the reader, the materials incorporated by reference are listed in the Finding Aid Table found at the end of this volume of the Code of Federal Regulations.

(b) The drawings and specifications incorporated in this part by reference are available for examination in the general reference section of Docket 79–04, Docket Section, National Highway Traffic Safety Administration, Room

§ 587.6

5109, 400 Seventh Street, SW., Washington, DC 20590. Copies may be obtained from Rowley-Scher Reprographics, Inc., 1111 14th Street, NW., Washington, DC 20005, telephone (202) 628-6667 or (202) 408-8789. The drawings and specifications are also on file in the reference library of the Office of the Federal Register, National Archives and Records Administration, Washington, DC.

§ 587.6 General description.

(a) The moving deformable barrier consists of component parts and component assemblies which are described in drawings and specifications that are set forth in this § 587.6 of this chapter (incorporated by reference; see § 587.5).

(b) The moving deformable barrier specifications are provided in the drawings shown in DSL-1278 through DSL-1287, except DSL-1282, and the drawing shown in DSL-1290 (DSL-1278 through DSL-1287, except for DSL-1282, and DSL-1290 are incorporated by reference; see § 587.5).

(1) The specifications for the final assembly of the moving deformable barrier are provided in the drawings shown in DSL-1278, dated June 2002.

(2) The specifications for the frame assembly of the moving deformable barrier are provided in the drawings shown in DSL-1281, dated August 20, 1980.

(3) The specifications for the face of the moving deformable barrier are provided in the drawings shown in DSL-1285, dated October 1991, and DSL-1286, dated August 20, 1980.

(4) The specifications for the ballast installation and details concerning the ballast plate are provided in drawings shown in DSL-1279 and DSL-1280, both dated August 20, 1980.

(5) The specifications for the hub assembly and details concerning the brake are provided in drawings shown in DSL-1283, dated October 1991.

(6) The specifications for the rear guide assembly are provided in drawings shown in DSL-1284, dated August 20, 1980.

(7) The specifications for the research axle assembly are provided in drawings shown in DSL-1287, dated October 1991.

(8) The specifications for the compliance axle assembly are provided in

49 CFR Ch. V (10-1-10 Edition)

drawings shown in DSL-1290, dated October 1991.

(c) In configuration 2 (with two cameras and camera mounts, a light trap vane, and ballast reduced), the moving deformable barrier (crabbable axle), including the impact surface, supporting structure, and carriage, weighs 3,015 pounds, has a track width of 74 inches, and has a wheelbase of 102 inches.

(d) In configuration 2, the moving deformable barrier has the following center of gravity:

X=44.2 inches rear of front axle
Y=0.3 inches left of longitudinal center line
Z=19.7 inches from ground.

(e) The moving deformable barrier has the following moment of inertia:

Pitch=1669 ft-lb-sec²
Roll=375 ft-lb-sec²
Yaw=1897 ft-lb-sec²

[55 FR 45779, Oct. 30, 1990; 56 FR 47011, Sept. 17, 1991, as amended at 57 FR 7558, Mar. 3, 1992; 68 FR 44472, July 29, 2003]

§§ 587.7-587.10 [Reserved]

Subpart C—Offset Deformable Barrier

SOURCE: 65 FR 17199, Mar. 31, 2000, unless otherwise noted.

§ 587.11 [Reserved]

§ 587.12 Incorporation by reference.

Society of Automotive Engineers (SAE) Recommended Practice J211/1 Rev. MAR 95, Instrumentation for Impact Tests-Part 1—Electronic Instrumentation, is incorporated by reference in § 587.15 in accordance with 5 U.S.C. 552(a) and 1 CFR part 51. A copy may be obtained from SAE at Society of Automotive Engineers, Inc., 400 Commonwealth Drive, Warrendale, PA 15096. A copy of the material may be inspected at NHTSA's Docket Section, 400 Seventh Street, S.W., room 5109, Washington, DC, or at the National Archives and Records Administration (NARA). For information on the availability of this material at NARA, call 202-741-6030, or go to: http://www.archives.gov/federal_register/code_of_federal_regulations/ibr_locations.html.

§ 587.13 General description.

The offset deformable barrier is comprised of two elements: a fixed rigid barrier and a deformable face (Figure 1). The fixed rigid barrier is adequate to not deflect or displace more than 10 mm during the vehicle impact. The deformable face consists of aluminum honeycomb and aluminum covering.

§ 587.14 Deformable face component dimensions and material specifications.

The dimensions of the deformable face are illustrated in Figure 1 of this subpart. The dimensions and materials of the individual components are listed separately below. All dimensions allow a tolerance of ± 2.5 mm (0.1 in) unless otherwise specified.

(a) Main honeycomb block.

(1) *Dimensions.* The main honeycomb block has a height of 650 mm (25.6 in) (in the direction of honeycomb ribbon axis), a width of 1,000 mm (39.4 in), and a depth of 450 mm (17.7 in) (in the direction of honeycomb cell axis).

(2) *Material.* The main honeycomb block is constructed of the following material. The honeycomb is manufactured out of aluminum 3003, with a foil thickness of 0.076 mm (0.003 in) ± 0.004 mm (0.002 in) a cell size of 19.14 mm (0.75 in), a density of 28.6 kg/m³ (1.78 lb/ft³) ± 2 kg/m³ (0.25 lb/ft³), and a crush strength of 0.342 MPa (49.6 psi) + 0% - 10%, measured in accordance with the certification procedure described in § 587.15.

(b) Bumper element honeycomb.

(1) *Dimensions.* The bumper element honeycomb has a height of 330 mm (13 in) (in the direction of honeycomb ribbon axis), a width of 1,000 mm (39.4 in), and a depth of 90 mm (3.5 in) (in the direction of honeycomb cell axis).

(2) *Material.* The bumper element honeycomb is constructed of the following material. The honeycomb is manufactured out of aluminum 3003, with a foil thickness of 0.076 mm (0.003 in) ± 0.004 mm (0.0002 in), a cell size of 6.4 mm (0.25 in) ± 1 mm (0.040 in), a density of 82.6 kg/m³ (5.15 lb/ft³) ± 3 kg/m³ (0.19 lb/ft³), and a crush strength of 1.711 MPa (248 psi) + 0% - 10%, measured in accordance with the certification procedure described in § 587.14.

(c) Backing sheet.

(1) *Dimensions.* The backing sheet has a height of 800 mm (31.5 in), a width of 1,000 mm (39.4 in), and a thickness of 2.0 mm (0.08 in) ± 0.1 mm (0.004 in).

(2) *Material.* The backing sheet is manufactured out of aluminum 5251/5052.

(d) Cladding sheet.

(1) *Dimensions.* The cladding sheet of the main honeycomb block has a total length of 1,700 mm (66.9 in), a width of 1,000 mm (39.4 in), and a thickness of 0.81 mm (0.03 in) ± 0.07 mm (0.003 in). It is shaped as indicated in Figure 1.

(2) *Material.* The cladding sheet of the main honeycomb block is manufactured out of aluminum 5251/5052.

(e) Bumper element honeycomb facing sheet.

(1) *Dimensions.* The bumper facing sheet has a height of 330 mm (13 in), a width of 1,000 mm (39.4 in), and a thickness of 0.81 mm (0.03 in) ± 0.07 mm (0.003 in).

(2) *Material.* The bumper element honeycomb facing sheet is manufactured out of aluminum 5251/5052.

(f) *Adhesive.* The adhesive used throughout is a two-part polyurethane. (such as Ciba-Geigy XB5090/1 resin with XB5304 hardener, or equivalent).

§ 587.15 Verification of aluminum honeycomb crush strength.

The following procedure is used to ascertain the crush strength of the main honeycomb block and the bumper element honeycomb, as specified in §§ 587.14(a)(2) and 587.14(b)(2).

(a) *Sample locations.* To ensure uniformity of crush strength across the whole of the deformable face, 8 samples are taken from 4 locations evenly spaced across the honeycomb material. Seven of these 8 samples must meet the crush strength requirements when tested in accordance with the following sections. The location of the samples depends on the size of the honeycomb material being tested. Four samples, each measuring 300 mm (11.8 in) \times 300 mm (11.8 in) \times 25 mm (1 in) thick are cut from the honeycomb material. (See Figure 2 for how to locate these samples on two different sizes of honeycomb material.) Each of these larger samples is cut into samples of the size specified in § 587.15(b). Verification is based on the testing of two samples

§587.16

from each of the four locations. The other two samples are retained for future verification, if necessary.

(b) *Sample size.* Samples of the following size are used for testing. The length is 150 mm (5.9 in) ±6 mm (0.24 in), the width is 150 mm (5.9 in) ±6 mm (0.24 in), and the thickness is 25 mm (1 in) ±2 mm (0.08 in). The walls of incomplete cells around the edge of the sample are trimmed as follows (See Figure 3). In the width (“W”) direction, the fringes (“f”) are no greater than 1.8 mm (0.07 in); in the length (“L”) direction, the fringes (“e”) are at least half the length of one bonded cell wall (“d”) (in the ribbon direction).

(c) *Area measurement.* The length of the sample is measured in three locations, 12.7 mm (0.5 in) from each end and in the middle, and recorded as L1, L2, and L3 (Figure 3). In the same manner, the width is measured and recorded as W1, W2, and W3 (Figure 3). These measurements are taken on the centerline of the thickness. The crush area is then calculated as:

$$A = \frac{(L1 + L2 + L3)}{3} \times \frac{(W1 + W2 + W3)}{3}$$

(d) *Crush rate and distance.* The sample is crushed at a rate of not less than 5.1 mm/min (0.2 in/min) and not more than 7.6 mm/min (0.29 in/min). The minimum crush distance is 16.5 mm (0.65 in). Force versus deflection data are collected in either analog or digital form for each sample tested. If analog data are collected, a means of converting the data to digital data must be made available. All digital data are collected at a rate consistent with SAE Recommended Practice J211/1 Rev. MAR 95 (see §587.12).

(e) *Crush strength determination.* Ignore all data prior to 6.4 mm (0.25 in) of crush and after 16.5 mm (0.65 in) of crush. Divide the remaining data into three sections or displacement intervals ($n = 1, 2, 3$) (see Figure 4) as follows. Interval one is from 6.4–9.7 mm (0.25–0.38 in) deflection, inclusive. Interval two is from 9.7–13.2 mm (0.38–0.52 in) deflection, exclusive. Interval three is from 13.2–16.5 mm (0.52–0.65 in) deflection, inclusive. Find the average for each section as follows:

49 CFR Ch. V (10–1–10 Edition)

$$F(n) = \frac{[F(n)l + \dots + F(n)m]}{m}; n = 1, 2, 3$$

where m represents the number of data points measured in each of the three intervals. Calculate the crush strength of each section as follows:

$$S(n) = \frac{F(n)}{A}; n = 1, 2, 3$$

(f) *Sample crush strength specification.* For a honeycomb sample to meet crush strength requirements, the following condition must be met. For the 0.342 MPa (49.6 psi) material, the strength must be equal to or greater than 0.308 MPa (45 psi) but less than or equal to 0.342 MPa (49.6 psi) for all three compression intervals. For the 1.711 MPa (248 psi) material the strength must be equal to or greater than 1.540 MPa (223 psi) but less than or equal to 1.711 MPa (248 psi) for all three compression intervals.

(g) *Testing hardware.* (1) The hardware used to verify crush strength is capable of applying a load of 13.3 kN (3,000 lb), over at least a 16.5 mm (0.65 in) stroke. The crush rate is constant and known. To ensure that the load is applied to the entire sample, the top and bottom crush plates are no smaller than 165 mm by 165 mm (6.5 in × 6.5 in). The engaging surfaces of the crush plates have a roughness approximately equivalent to 60 grit sandpaper. The bottom crush plate is marked to ensure that the applied load is centered on the sample.

(2) The crush plate assemblies have an average angular rigidity (about axes normal to the direction of crush) of at least 1017 Nm/deg (750 ft-lb/deg), over the range of 0 to 203 Nm (0 to 150 ft-lb) applied torque.

§587.16 Adhesive bonding procedure.

Immediately before bonding, aluminum sheet surfaces to be bonded are thoroughly cleaned using a suitable solvent, such as 1-1-1 Trichloroethane. This is carried out at least twice and more often if required to eliminate grease or dirt deposits. The cleaned surfaces are abraded using 120 grit abrasive paper. Metallic/silicon carbide abrasive paper is not to be used. The surfaces are thoroughly abraded and

the abrasive paper changed regularly during the process to avoid clogging, which could lead to a polishing effect. Following abrading, the surfaces are thoroughly cleaned again, as above. In total, the surfaces are solvent-cleaned at least four times. All dust and deposits left as a result of the abrading process are removed, as these can adversely affect bonding. The adhesive is applied to one surface only, using a ribbed rubber roller. In cases where honeycomb is to be bonded to aluminum sheet, the adhesive is applied to the aluminum sheet only. A maximum pressure of 0.5 kg/m² (11.9 lb/ft²) is applied evenly over the surface, giving a maximum film thickness of 0.5 mm (0.02 in).

§ 587.17 Construction.

(a) The main honeycomb block is bonded to the backing sheet with adhesive such that the cell axes are perpendicular to the sheet. The cladding sheet is adhesively bonded to the front surface of the main honeycomb block. The top and bottom surfaces of the cladding sheet are not bonded to the main honeycomb block but are positioned close to it. The cladding sheet is adhesively bonded to the backing sheet at the mounting flanges. The bumper element honeycomb is adhesively bonded to the front of the cladding sheet such that the cell axes are perpendicular to the sheet. The bottom of the bumper element honeycomb is flush with the bottom surface of the cladding sheet. The bumper facing sheet is adhesively bonded to the front of the bumper element honeycomb.

(b) The bumper element honeycomb is divided into three equal sections by means of two horizontal slots. These slots are cut through the entire depth of the bumper element and extend the whole width of the bumper. The slots are cut using a saw; their width is the width of the blade used which do not exceed 4.0 mm (0.16 in).

(c) Clearance holes for mounting the deformable face are drilled in the cladding sheet mounting flanges (shown in Figure 5). The holes are 20 mm (0.79 in) in diameter. Five holes are drilled in the top flange at a distance of 40 mm (1.57 in) from the top edge of the flange and five holes in the bottom flange at a distance of 40 mm (1.6 in) from the

bottom edge of the flange. The holes are spaced at 100 mm (3.9 in), 300 mm (11.8 in), 500 mm (19.7 in), 700 mm (27.5 in), 900 mm (35.4 in) horizontally, from either edge of the barrier. All holes are drilled within ± 1 mm (0.04 in) of the nominal distances.

§ 587.18 Dimensions of fixed rigid barrier.

(a) The fixed rigid barrier has a mass of not less than 7×10^4 kg (154,324 lb).

(b) The height of the fixed rigid barrier is at least as high as the highest point on the vehicle at the intersection of the vertical transverse plane tangent to the forwardmost point of both front tires, when the tires are parallel to the longitudinal centerline of the vehicle, and the vertical plane through the longitudinal centerline of the vehicle.

§ 587.19 Mounting.

(a) The deformable face is rigidly attached to the edge of the fixed rigid barrier or to some rigid structure attached thereto. The front of the fixed rigid barrier to which the deformable face is attached is flat (continuous over the height and width of the face and vertical ± 1 degree and perpendicular ± 1 degree to the axis of the run-up track). The edge of the deformable face is aligned with the edge of the fixed rigid barrier appropriate for the side of the vehicle to be tested.

(b) The deformable face is attached to the fixed rigid barrier by means of ten bolts, five in the top mounting flange and five in the bottom, such that the bottom of the bumper element honeycomb is 200 mm (7.8 in) ± 15 mm (0.6 in) from the ground. These bolts are at least 8 mm (0.3 in) in diameter. Steel clamping strips are used for both the top and bottom mounting flanges (Figure 1). These strips are 60 mm (2.4 in) high and 1000 mm (39.4 in) wide and have thickness of at least 3 mm (0.12 in). Five clearance holes of 20 mm (0.8 in) diameter are drilled in both strips to correspond with those in the mounting flange on the deformable face cladding sheet (see § 586.17(c)).

FIGURES TO SUBPART C OF PART 587

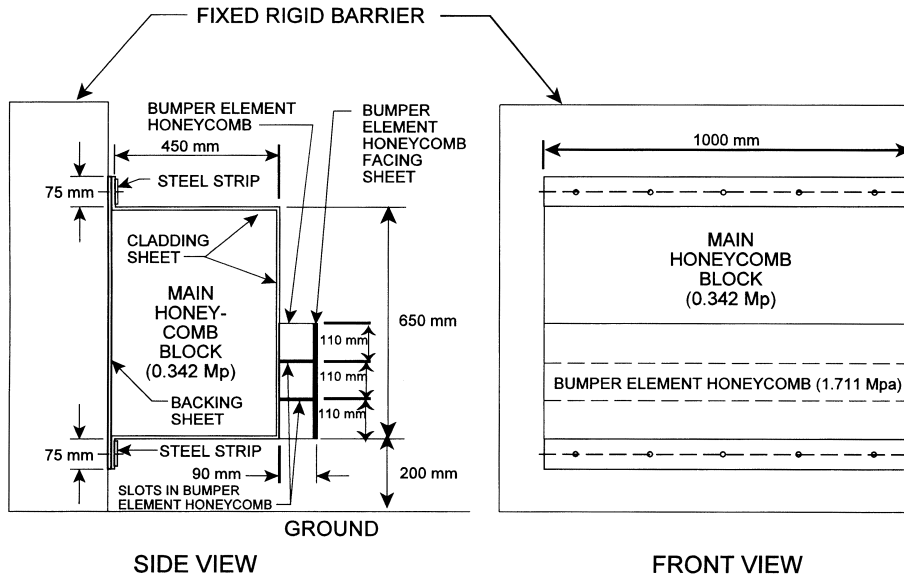
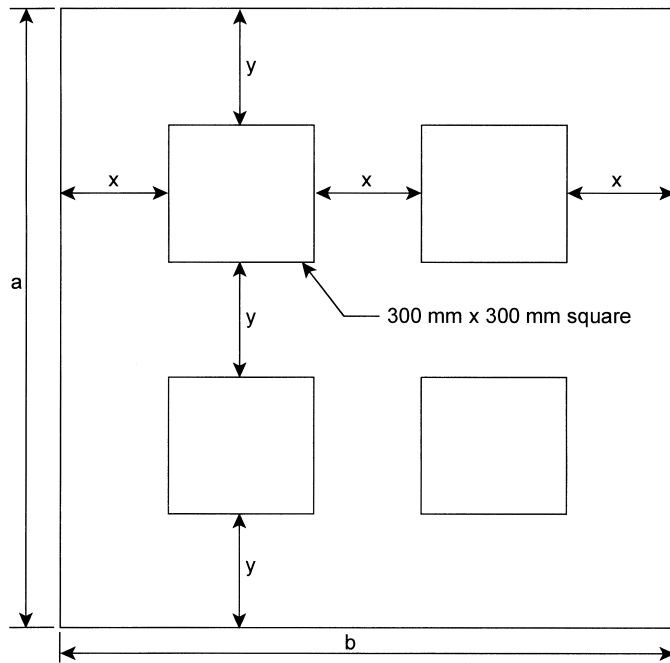
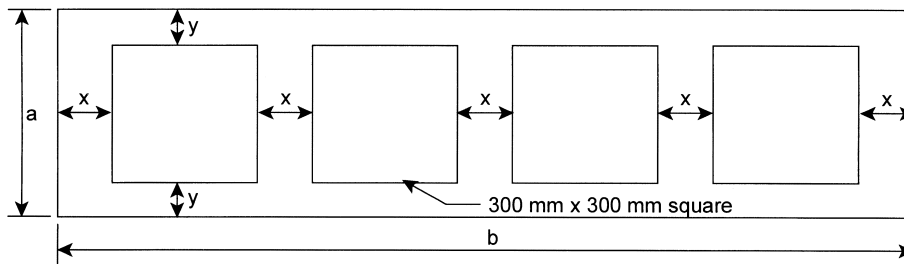


FIGURE 1
OFFSET BARRIER



If $a \geq 900$ mm: $x = 1/3 (b - 600)$ mm and $y = 1/3 (a - 600)$ mm (for $a < b$)



If $a < 900$ mm: $x = 1/5 (b - 1200)$ mm and $y = 1/2 (a - 300)$ mm (for $a \leq b$)

FIGURE 2

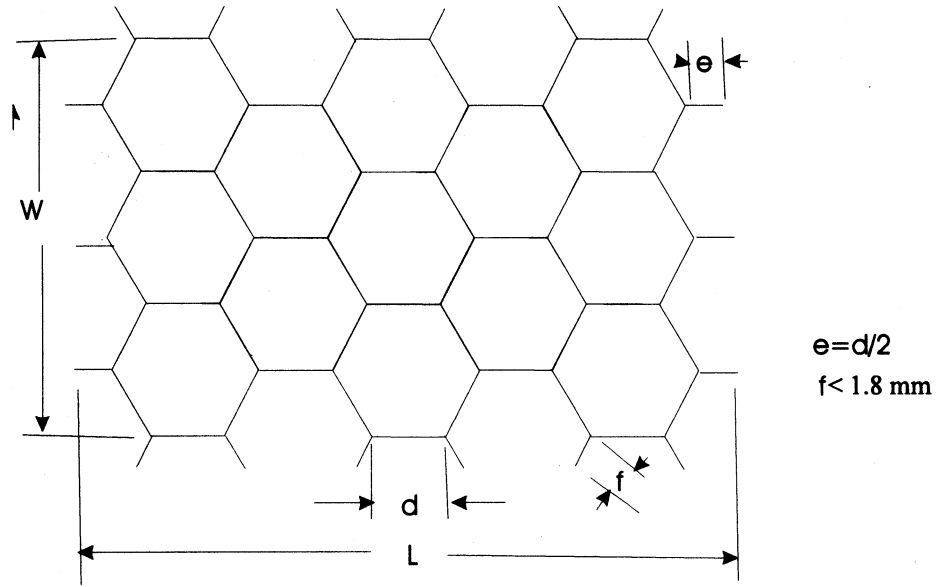


Figure 3
Honeycomb Axes and Measured Dimensions

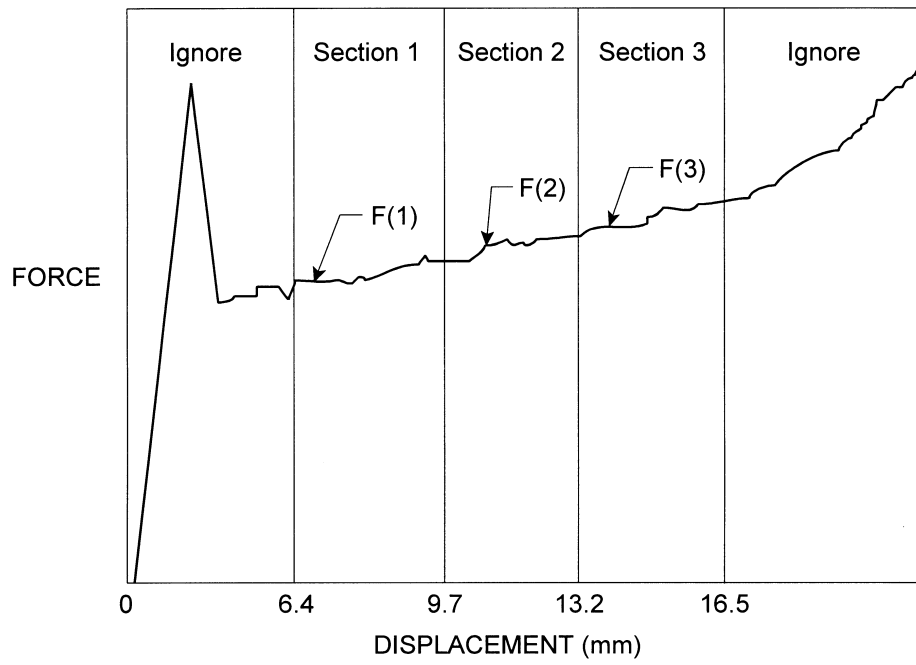


FIGURE 4
CRUSH FORCE AND DISPLACEMENT

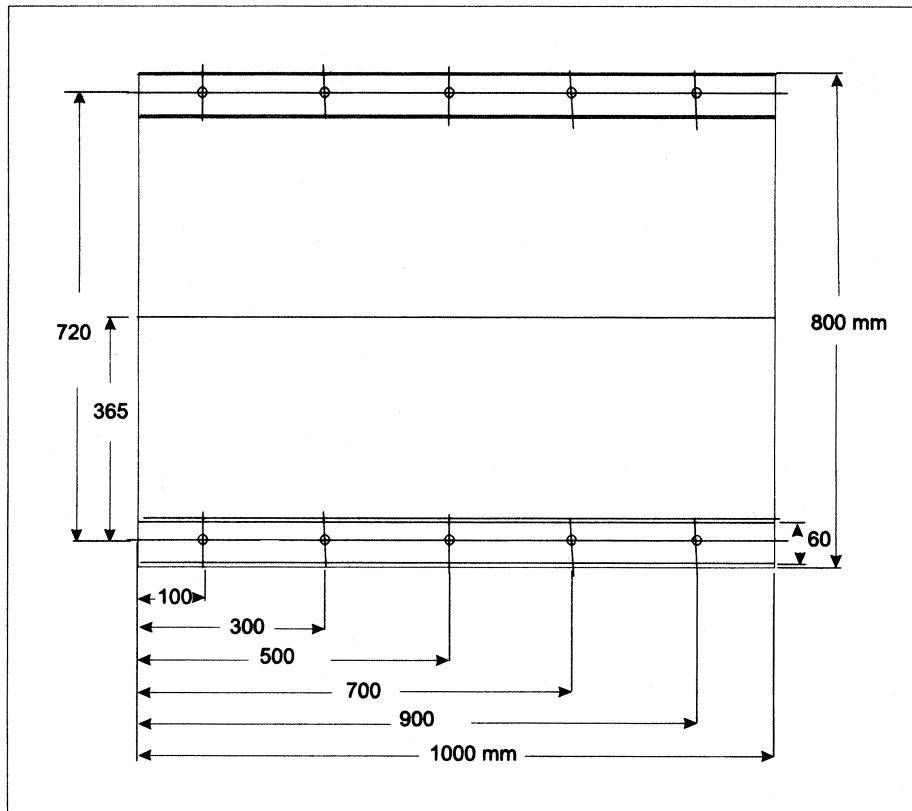


Figure 5
Positions of Holes for Deformable Face Mounting

PART 588—CHILD RESTRAINT SYSTEMS RECORDKEEPING REQUIREMENTS

- Sec.
- 588.1 Scope.
- 588.2 Purpose.
- 588.3 Applicability.
- 588.4 Definitions.
- 588.5 Records.
- 588.6 Record retention.

AUTHORITY: 49 U.S.C. 322, 30111, 30115, 30117, and 30166; delegation of authority at 49 CFR 1.50.

SOURCE: 57 FR 41438, Sept. 10, 1992, unless otherwise noted.

§ 588.1 Scope.

This part establishes requirements for manufacturers of child restraint systems to maintain lists of the names and addresses of child restraint owners.

§ 588.2 Purpose.

The purpose of this part is to aid manufacturers in contacting the owners of child restraints during notification campaigns conducted in accordance with 49 CFR part 577, and to aid the National Highway Traffic Safety Administration in determining whether a manufacturer has met its recall responsibilities.

§ 588.3 Applicability.

This part applies to manufacturers of child restraint systems, except factory-installed built-in restraints.

§ 588.4 Definitions.

(a) *Statutory definitions.* All terms defined in section 102 of the National Traffic and Motor Vehicle Safety Act (15 U.S.C. 1391) are used in their statutory meaning.

(b) *Motor Vehicle Safety Standard definitions.* Unless otherwise indicated, all terms used in this part that are defined in the Motor Vehicle Safety Standards, part 571 of this subchapter (hereinafter "the Standards"), are used as defined in the Standards.

(c) *Definitions used in this part.*

Child restraint system is used as defined in S4 of 49 CFR 571.213, *Child Restraint Systems*.

Factory-installed built-in child restraint system is used as defined in S4 of 49 CFR 571.213.

Owners include purchasers.

Registration form means the form provided with a child restraint system in compliance with the requirements of 49 CFR 571.213, and any communication from an owner of a child restraint to the manufacturer that provides the restraint's model name or number and the owner's name and mailing address.

§ 588.5 Records.

Each manufacturer, or manufacturer's designee, shall record and maintain records of the owners of child restraint systems who have submitted a registration form. The record shall be in a form suitable for inspection such as computer information storage devices or card files, and shall include the names, mailing addresses, and if collected, se-mail addresses of the owners, and the model name or number and date of manufacture (month, year) of the owner's child restraint systems.

[70 FR 53579, Sept. 9, 2005]

§ 588.6 Record retention.

Each manufacturer, or manufacturer's designee, shall maintain the information specified in § 588.5 of this part for a registered restraint system for a period of not less than six years from

the date of manufacture of that restraint system.

PARTS 589–590 [RESERVED]

PART 591—IMPORTATION OF VEHICLES AND EQUIPMENT SUBJECT TO FEDERAL SAFETY, BUMPER AND THEFT PREVENTION STANDARDS

- Sec.
- 591.1 Scope.
- 591.2 Purpose.
- 591.3 Applicability.
- 591.4 Definitions.
- 591.5 Declarations required for importation.
- 591.6 Documents accompanying declarations.
- 591.7 Restrictions on importations.
- 591.8 Conformance bond and conditions.
- 591.9 Petitions for remission or mitigation of forfeiture.
- 591.10 Offer of cash deposits or obligations of the United States in lieu of sureties on bonds.

APPENDIX A TO PART 591—SECTION 591.5(f)
BOND FOR THE ENTRY OF A SINGLE VEHICLE

APPENDIX B TO PART 591—SECTION 591.5(f)
BOND FOR THE ENTRY OF MORE THAN A SINGLE VEHICLE

APPENDIX C TO PART 591—POWER OF ATTORNEY AND AGREEMENT

AUTHORITY: Pub. L. 100-562, 49 U.S.C. 322(a), 30117, 30141-30147; delegation of authority at 49 CFR 1.50.

SOURCE: 54 FR 40078, Sept. 29, 1989, unless otherwise noted.

§ 591.1 Scope.

This part establishes procedures governing the importation of motor vehicles and motor vehicle equipment subject to the Federal motor vehicle safety, bumper, and theft prevention standards.

[55 FR 11378, Mar. 28, 1990]

§ 591.2 Purpose.

The purpose of this part is to ensure that motor vehicles and motor vehicle equipment permanently imported into the United States conform with theft prevention standards issued under part 541 of this chapter and that they conform with, or are brought into conformity with, all applicable Federal motor vehicle safety standards issued under part 571 of this chapter and

§ 591.3

bumper standards issued under part 581 of this chapter. The purpose of this part is also to ensure that nonconforming vehicles and equipment items imported on a temporary basis are ultimately either exported or abandoned to the United States.

[55 FR 11378, Mar. 28, 1990]

§ 591.3 Applicability.

This part applies to any person offering a motor vehicle or item of motor vehicle equipment for importation into the United States.

[55 FR 11378, Mar. 28, 1990]

§ 591.4 Definitions.

All terms used in this part that are defined in 49 U.S.C. 30102, 32101, 32301, 32502, and 33101 are used as defined in those sections except that the term "model year" is used as defined in part 593 of this chapter.

Administrator means the Administrator of NHTSA.

NHTSA means the National Highway Traffic Safety Administration of the Department of Transportation.

Dutiable value means entered value, as determined by the Secretary of the Treasury.

Original manufacturer means the entity responsible for the original manufacture or assembly of a motor vehicle, and does not include any person (other than such entity) who converts the motor vehicle after its manufacture to conformance with the Federal motor vehicle safety standards.

Reconstructed motor vehicle means a motor vehicle whose body is less than 25 years old and which is mounted on a chassis or frame that is not its original chassis or frame and that is less than 25 years old.

Salvage motor vehicle means a motor vehicle, whether or not repaired, which has been:

(1) Wrecked, destroyed, or damaged, to the extent that the total estimated or actual cost of parts and labor to rebuild or reconstruct the motor vehicle to its pre-accident condition and for legal operation on the streets, roads, or highways, exceeds 75 percent of its retail value at the time it was wrecked, destroyed, or damaged; or

49 CFR Ch. V (10–1–10 Edition)

(2) Wrecked, destroyed, or damaged, to which an insurance company acquires ownership pursuant to a damage settlement (other than a damage settlement in connection with a recovered theft vehicle unless such motor vehicle sustained sufficient damage to meet the 75 percent threshold specified in the first sentence); or

(3) Voluntarily designated as such by its owner, without regard to the extent of the motor vehicle's damage and repairs.

[54 FR 40078, Sept. 29, 1989, as amended at 55 FR 3747, Feb. 5, 1990; 55 FR 11378, Mar. 28, 1990; 59 FR 52097, Oct. 14, 1994; 60 FR 57954, Nov. 24, 1995; 69 FR 52092, Aug. 24, 2004]

§ 591.5 Declarations required for importation.

No person shall import a motor vehicle or item of motor vehicle equipment into the United States unless, at the time it is offered for importation, its importer files a declaration, in duplicate, which declares one of the following:

(a)(1) The vehicle was not manufactured primarily for use on the public roads and thus is not a motor vehicle subject to the Federal motor vehicle safety, bumper, and theft prevention standards; or

(2) The equipment item is not a system, part, or component of a motor vehicle and thus is not an item of motor vehicle equipment subject to the Federal motor vehicle safety, bumper, and theft prevention standards.

(b) The vehicle or equipment item conforms with all applicable safety standards (or the vehicle does not conform solely because readily attachable equipment items which will be attached to it before it is offered for sale to the first purchases for purposes other than resale are not attached), and bumper and theft prevention standards, and bears a certification label or tag to that effect permanently affixed by the original manufacturer to the vehicle, or by the manufacturer to the equipment item or its delivery container, in accordance with, as applicable, parts 541, 555, 567, 568, and 581, or 571 (for certain equipment items) of this chapter.

(c) The vehicle or equipment item does not comply with all applicable

Federal motor vehicle safety, bumper, and theft prevention standards, but is intended solely for export, and the vehicle or equipment item, and the outside of the container of the equipment item, if any, bears a label or tag to that effect.

(d) The vehicle does not conform with all applicable Federal motor vehicle safety, bumper, and theft prevention standards, but the importer is eligible to import it because:

(1) (S)he is a nonresident of the United States and the vehicle is registered in a country other than the United States,

(2) (S)he is temporarily importing the vehicle for personal use for a period not to exceed one year, and will not sell it during that time,

(3) (S)he will export it not later than the end of one year after entry, and

(4) The declaration contains the importer's passport number and country of issue.

(e) The vehicle or equipment item requires further manufacturing operations to perform its intended function, other than the addition of readily attachable equipment items such as mirrors, wipers, or tire and rim assemblies, or minor finishing operations such as painting, and any part of such vehicle that is required to be marked by part 541 of this chapter is marked in accordance with that part.

(f) The vehicle does not conform with all applicable Federal motor vehicle safety and bumper standards (but does conform with all applicable Federal theft prevention standards), but the importer is eligible to import it because:

(1) The importer has furnished a bond in an amount equal to 150% of the dutiable value of the vehicle, containing the terms and conditions specified in section 591.8; and

(2)(i) The importer has registered with NHTSA pursuant to part 592 of this chapter, and such registration has not been revoked or suspended, and the Administrator has determined pursuant to part 593 of this chapter that the model and model year of the vehicle to be imported is eligible for importation into the United States; or

(ii) The importer has executed a contract or other agreement with an im-

porter who has registered with NHTSA pursuant to part 592 of this chapter and whose registration has not been suspended or revoked; and the Administrator has determined pursuant to part 593 of this chapter that the model and model year of the vehicle to be imported is eligible for importation into the United States; and

(3) The vehicle is not a salvage motor vehicle or a reconstructed motor vehicle.

(g) (For importations for personal use only) The vehicle was certified by its original manufacturer as complying with all applicable Canadian motor vehicle safety standards and its original manufacturer has informed NHTSA that it complies with all applicable Federal motor vehicle safety, bumper, and theft prevention standards, or that it complies with all such standards except for the labeling requirements of Federal Motor Vehicle Safety Standards Nos. 101 and 110 or 120, and/or the specifications of Federal Motor Vehicle Safety Standard No. 108 relating to daytime running lamps. The vehicle is not a salvage motor vehicle, a repaired salvage motor vehicle, or a reconstructed motor vehicle.

(h) The vehicle does not conform with all applicable Federal motor vehicle safety, bumper, and theft prevention standards, but the importer is eligible to import it because (s)he:

(1)(i) Is a member of the personnel of a foreign government on assignment in the United States, or a member of the Secretariat of a public international organization so designated under the International Organization Immunities Act, and within the class of persons for whom free entry of motor vehicles has been authorized by the Department of State;

(ii) Is importing the motor vehicle on a temporary basis for the personal use of the importer, and will register it through the Office of Foreign Missions of the Department of State;

(iii) Will not sell the vehicle to any person in the United States, other than a person eligible to import a vehicle under this paragraph; and

(iv) Will obtain from the Office of Foreign Missions of the Department of State, before departing the United States at the conclusion of a tour of

§ 591.6

duty, an ownership title to the vehicle good for export only; or

(2)(i) Is a member of the armed forces of a foreign country on assignment in the United States;

(ii) Is importing the vehicle on a temporary basis, and for the personal use of the importer;

(iii) Will not sell the vehicle to any person in the United States, other than to a person eligible to import a vehicle under this subsection; and

(iv) Will export the vehicle upon departing the United States at the conclusion of a tour of duty.

(i)(1) The vehicle is 25 or more years old.

(2) The equipment item was manufactured on a date when no applicable safety or theft prevention standard was in effect.

(j)(1) The vehicle or equipment item does not conform with all applicable Federal motor vehicle safety and bumper standards, but is being imported solely for the purpose of:

(i) Research;

(ii) Investigations;

(iii) Show or display;

(iv) Demonstrations or training; or

(v) Competitive racing events;

(2)(i) The importer has received written permission from NHTSA; or

(ii) The importer is an original manufacturer of motor vehicles (or a wholly owned subsidiary thereof) that are certified to comply with all applicable Federal motor vehicle safety standards; and

(3) The importer will provide the Administrator with documentary proof of export or destruction not later than 30 days following the end of the period for which the vehicle has been admitted into the United States.

(k) The equipment item is subject to the theft prevention standard, and is marked in accordance with the requirements of part 541 of this chapter.

[54 FR 40078, Sept. 29, 1989, as amended at 55 FR 3747, Feb. 5, 1990; 55 FR 11378, Mar. 28, 1990; 55 FR 17439, Apr. 25, 1990; 57 FR 2047, Jan. 17, 1992; 57 FR 44703, Sept. 29, 1992; 59 FR 31560, June 20, 1994; 64 FR 37882, July 14, 1999; 69 FR 52092, Aug. 24, 2004]

49 CFR Ch. V (10–1–10 Edition)

§ 591.6 Documents accompanying declarations.

Declarations of eligibility for importation made pursuant to § 591.5 must be accompanied by the following certification and documents, where applicable.

(a) A declaration made pursuant to § 591.5(a) shall be accompanied by a statement substantiating that the vehicle was not manufactured for use on the public roads, or that the equipment item was not manufactured for use on a motor vehicle or is not an item of motor vehicle equipment.

(b) A declaration made pursuant to § 591.5(e) shall be accompanied by:

(1) (For a motor vehicle) a document meeting the requirements of § 568.4 of part 568 of this chapter.

(2) (For an item of motor vehicle equipment) a written statement issued by the manufacturer of the equipment item which states the applicable Federal motor vehicle safety standard(s) with which the equipment item is not in compliance, and which describes the further manufacturing required for the equipment item to perform its intended function.

(c) A declaration made pursuant to paragraph (f) of § 591.5, and under a bond for the entry of a single vehicle, shall be accompanied by a bond in the form shown in appendix A to this part, in an amount equal to 150% of the dutiable value of the vehicle, or, if under bond for the entry of more than one vehicle, shall be accompanied by a bond in the form shown in appendix B to this part and by Customs Form CF 7501, for the conformance of the vehicle(s) with all applicable Federal motor vehicle safety and bumper standards, or, if conformance is not achieved, for the delivery of such vehicles to the Secretary of Homeland Security for export at no cost to the United States, or for its abandonment.

(d) A declaration made pursuant to § 591.5(f) by an importer who is not a Registered Importer shall be accompanied by a copy of the contract or other agreement that the importer has with a Registered Importer to bring the vehicle into conformance with all applicable Federal motor vehicle safety standards.

(e) A declaration made pursuant to § 591.5(h) shall be accompanied by a copy of the importer's official orders, or, if a qualifying member of the personnel of a foreign government on assignment in the United States, the name of the embassy to which the importer is accredited.

(f) A declaration made pursuant to § 591.5(j) shall be accompanied by the following documentation:

(1) A declaration made pursuant to § 591.5(j)(1)(i), (ii), (iv), or (v) and (j)(2)(i) shall be accompanied by a letter from the Administrator authorizing importation pursuant to § 591.5(j)(1)(i), (ii), (iv), or (v) and (j)(2)(i). Any person seeking to import a motor vehicle or motor vehicle equipment pursuant to these sections shall submit, in advance of such importation, a written request to the Administrator containing a full and complete statement identifying the vehicle or equipment, its make, model, model year or date of manufacture, VIN if a motor vehicle, and the specific purpose(s) of importation. The discussion of purpose(s) shall include a description of the use to be made of the vehicle or equipment. If use on the public roads is an integral part of the purpose for which the vehicle or equipment is imported, the statement shall request permission for use on the public roads, describing the purpose which makes such use necessary, and stating the estimated period of time during which use of the vehicle or equipment on the public roads is necessary. The request shall also state the intended means of final disposition, and disposition date, of the vehicle or equipment after completion of the purposes for which it is imported. The request shall be addressed to Director, Office of Vehicle Safety Compliance (NSA-32), National Highway Traffic Safety Administration, Room 6111, 400 Seventh Street, SW, Washington, DC 20590.

(2) A declaration made pursuant to § 591.5(j)(1)(iii) and (j)(2)(i) shall be accompanied by a letter from the Administrator authorizing importation pursuant to § 591.5(j)(1)(iii) and (j)(2)(i). Any person seeking to import a motor vehicle or motor vehicle equipment pursuant to those sections shall submit, in advance of such importation, a written request to the Administrator

containing a full and complete statement identifying the equipment item or the vehicle and its make, model, model year or date of manufacture, VIN, and mileage at the time the request is made. The importer's written request to the Administrator shall explain why the vehicle or equipment item is of historical or technological interest. The importer shall also provide a statement that, until the vehicle is not less than 25 years old, (s)he shall not sell, or transfer possession of, or title to, the vehicle, and shall not license it for use, or operate it on the public roads, except under such terms and conditions as the Administrator may authorize. If the importer wishes to operate the vehicle on the public roads, the request to the Administrator shall include a description of the purposes for which (s)he wishes to use it on the public roads, a copy of an insurance policy or a contract to acquire an insurance policy, which contains as a condition thereof that the vehicle will not accumulate mileage of more than 2,500 miles in any 12-month period and a statement that the importer shall maintain such policy in effect until the vehicle is not less than 25 years old, a statement that the importer will allow the Administrator to inspect the vehicle at any time after its importation to verify that the accumulated mileage of the vehicle is not more than 2,500 miles in any 12-month period, and a statement that the vehicle will not be used on the public roads unless it is in compliance with the regulations of the Environmental Protection Agency.

(3) A declaration made pursuant to § 591.5(j)(2)(ii) shall be accompanied by the written statement of its importer describing the use to be made of the vehicle or equipment item. If use on the public roads is an integral part of the purpose for which the vehicle or equipment item is imported, the statement shall describe the purpose which makes such use necessary, state the estimated period of time during which use of the vehicle or equipment item on the public roads is necessary, and state the intended means of final disposition (and disposition date) of the vehicle or

§ 591.7

49 CFR Ch. V (10–1–10 Edition)

equipment item after completion of the purpose for which it is imported.

[54 FR 40078, Sept. 29, 1989, as amended at 55 FR 3747, Feb. 5, 1990; 55 FR 6994, Feb. 28, 1990; 55 FR 11379, Mar. 28, 1990; 57 FR 2047, Jan. 17, 1992; 57 FR 29043, June 30, 1992; 58 FR 12908, Mar. 8, 1993; 59 FR 52097, Oct. 14, 1994; 60 FR 57954, Nov. 24, 1995; 64 FR 37883, July 14, 1999; 69 FR 52092, Aug. 24, 2004]

§ 591.7 Restrictions on importations.

(a) A vehicle or equipment item which has entered the United States under a declaration made pursuant to § 591.5(j), and for which a Temporary Importation Bond has been provided to the Secretary of the Treasury, shall not remain in the United States for a period that exceeds 3 years from its date of entry.

(b) If the importer of a vehicle or equipment item under § 591.5(j) does not intend to export or destroy the vehicle or equipment item not later than 3 years after the date of entry, and intends to pay duty to the U.S. Customs Service on such vehicle or equipment item, the importer shall request permission in writing from the Administrator for the vehicle or equipment item to remain in the United States for an additional period of time not to exceed 5 years from the date of entry. Such a request must be received not later than 60 days before the date that is 3 years after the date of entry. Such vehicle or equipment item shall not remain in the United States for a period that exceeds 5 years from the date of entry, unless further written permission has been obtained from the Administrator.

(c) An importer of a vehicle which has entered the United States under a declaration made pursuant to § 591.5(j)(2)(i) shall not sell, or transfer possession of, or title to, the vehicle, and shall not license it for use, or operate it on the public roads, except under such terms and conditions as the Administrator may authorize in writing. An importer of a vehicle which has entered the United States under a declaration made pursuant to § 591.5(j)(2)(ii) shall at all times retain title to it.

(d) Any violation of a term or condition imposed by the Administrator in a letter authorizing importation for on-

road use under § 591.5(j), or a change of status under paragraph (e) of this section, including a failure to allow inspection upon request to verify that the accumulated mileage of the vehicle is not more than 2,500 miles in any 12-month period, shall be considered a violation of 49 U.S.C. 30112(a) for which a civil penalty may be imposed. Such a violation will also act to void the authorization and require the exportation of the vehicle. With respect to importations under § 591.6(f)(2) or a change of status to an importation for show or display as provided under paragraph (e) of this section, if the Administrator has reason to believe that a violation has occurred, the Administrator may tentatively conclude that a term of entry has been violated, but shall make no final conclusion until the importer or owner has been afforded an opportunity to present data, views, and arguments as to why there is no violation or why a penalty should not be imposed.

(e) If the importer of a vehicle under § 591.5(f)(2)(ii) has been notified in writing by the Registered Importer with which it has executed a contract or other agreement that the registration of the Registered Importer has been suspended (for other than the first time) or revoked, pursuant to § 592.7 of this chapter, and that it has not affixed a certification label on the vehicle and/or filed a certification of conformance with the Administrator as required by § 592.6 of this chapter, and that it therefore may not release the vehicle for the importer, the importer shall execute a contract or other agreement with another Registered Importer for the certification of the vehicle and submission of the certification of conformance to the Administrator. The Administrator shall toll the 120-day period for submission of a certification to the Administrator pursuant to § 592.6(d) of this chapter during the period from the date of the Registered Importer's notification to the importer until the date of the contract with the substitute Registered Importer.

[54 FR 40078, Sept. 29, 1989, as amended at 55 FR 6994, Feb. 28, 1990; 57 FR 2047, Jan. 17, 1992; 58 FR 12908, Mar. 8, 1993; 59 FR 31560, June 20, 1994; 64 FR 37883, July 14, 1999; 69 FR 52092, Aug. 24, 2004]

§ 591.8 Conformance bond and conditions.

(a) The bond required under section 591.6(c) for importation of a vehicle not originally manufactured to conform with all applicable standards issued under part 571 and part 581 of this chapter shall cover only one motor vehicle, and shall be in an amount equal to 150% of the dutiable value of the vehicle. However, a registered importer may enter vehicles under a bond of a continuing nature that covers an indefinite number of motor vehicles 150% of whose total dutiable value at any point in time does not exceed \$1,000,000.

(b) The principal on the bond shall be the importer of the vehicle.

(c) The surety on the bond shall possess a certificate of authority to underwrite Federal bonds. (See list of certificated sureties at 54 FR 27800, June 30, 1989)

(d) In consideration of the release from the custody of the Bureau of Customs and Border Protection, or the withdrawal from a Customs bonded warehouse into the commerce of, or for consumption in, the United States, of a motor vehicle not originally manufactured to conform to applicable standards issued under part 571 and part 581 of this chapter, the obligors (principal and surety) shall agree to the following conditions of the bond:

(1) To have such vehicle brought into conformity with all applicable standards issued under part 571 and part 581 of this chapter within the number of days after the date of entry that the Administrator has established for such vehicle (to wit, 120 days);

(2) In the case of a vehicle imported pursuant to section 591.5(f), to file (or if not a Registered Importer, to cause the Registered Importer of the vehicle to file) with the Administrator, a certificate that the vehicle complies with each Federal motor vehicle safety and bumper standard in the year that the vehicle was manufactured and which applies in such year to the vehicle; or

(3) In the case of a Registered Importer, not to release custody of the vehicle to any person for license or registration for use on public roads, streets, or highways, or license or register the vehicle from the date of entry until 30 calendar days after it has cer-

tified compliance of the vehicle to the Administrator, unless the Administrator has notified the principal before 30 calendar days that (s)he has accepted the certification, and that the vehicle and bond may be released, except that no such release shall be permitted, before or after the 30th calendar day, if the principal has received written notice from the Administrator that an inspection of the vehicle will be required or that there is reason to believe that such certification is false or contains a misrepresentation;

(4) In the case of a Registered Importer, to cause the vehicle to be available for inspection, if the principal has received written notice from the Administrator that an inspection is required.

(5) In the case of a Registered Importer, not to release the vehicle until the Administrator is satisfied with the certification and any modification thereof, if the principal has received written notice from the Administrator that there is reason to believe that the certification is false or contains a misrepresentation.

(6) If the principal has received written notice from the Administrator that the vehicle has been found not to comply with all applicable Federal motor vehicle safety and bumper standards, and written demand that the vehicle be abandoned to the United States, or delivered to the Secretary of Homeland Security for export (at no cost to the United States), or to abandon the vehicle to the United States, or to deliver the vehicle, or cause the vehicle to be delivered to, the custody of the Bureau of Customs and Border Protection at the port of entry listed above, or to any other port of entry, and to secure all documents necessary for exportation of the vehicle from the United States at no cost to the United States, or in default of abandonment or redelivery after prior notice by the Administrator to the principal, to pay to the Administrator the amount of the bond.

(e) If the principal defaults on the obligation of paragraph (d)(6) of this section, to abandon the vehicle to the United States or to redeliver the vehicle to the custody of a District Director of Customs and to execute all documents necessary for its exportation,

§ 591.9

the obligors shall pay to the Administrator the amount of the bond given under the provisions of this section.

[55 FR 11379, Mar. 28, 1990, as amended at 59 FR 31560, June 20, 1994; 69 FR 52092, Aug. 24, 2004]

§ 591.9 Petitions for remission or mitigation of forfeiture.

(a) After a bond has been forfeited, a principal and/or a surety may petition for remission of forfeiture. A principal and/or surety may petition for mitigation of forfeiture only if the motor vehicle has been imported pursuant to paragraph 591.5(f) and the condition not met relates to the compliance of a passenger motor vehicle with part 581 of this chapter.

(b) A petition for remission or mitigation shall:

(1) Be addressed to the Administrator, identified as either a petition for remission or for mitigation, submitted in triplicate, and signed by the principal and/or the surety.

(2) State the make, model, model year, and VIN of the vehicle involved, and contain the Customs Entry number under which the vehicle entered the United States.

(3) State the facts and circumstances relied on by the petitioner to justify remission or mitigation.

(4) Be filed within 30 days from the date of the mailing of the notice of forfeiture incurred.

(c) A false statement contained in a petition may subject the petitioner to prosecution under the provisions of 18 U.S.C. 1001.

(d) If the Administrator finds that all conditions of the bond have, in fact, been fulfilled, the forfeiture is remitted.

(e) A decision to mitigate a forfeiture upon condition that a stated amount is paid shall be effective for not more than 60 days from the date of notice to the petitioner of such decision. If payment of the stated amount is not made, or arrangements made for delayed or installment payment, the full claim of forfeiture shall be deemed applicable. The Administrator shall collect the claim, or, if unable to collect the claim

49 CFR Ch. V (10–1–10 Edition)

within 120 days, shall refer the matter to the Department of Justice.

[55 FR 11380, Mar. 28, 1990, as amended at 59 FR 31560, June 20, 1994]

§ 591.10 Offer of cash deposits or obligations of the United States in lieu of sureties on bonds.

(a) In lieu of sureties on any bond required under § 591.6(c), an importer may offer United States money, United States bonds (except for savings bonds), United States certificates of indebtedness, Treasury notes, or Treasury bills in an amount equal to the amount of the bond.

(b) At the time the importer deposits any obligation of the United States, other than United States money, with the Administrator, (s)he shall deliver a duly executed power of attorney and agreement, in the form shown in appendix C to this part, authorizing the Administrator or delegate of the Administrator, in case of any default in the performance of any of the conditions of the bond, to sell the obligation so deposited, and to apply the proceeds of sale, in whole or in part, to the satisfaction of any penalties for violations of 49 U.S.C. 30112 and 49 U.S.C. 32506 arising by reasons of default.

(c) If the importer deposits money of the United States with the Administrator, the Administrator, or delegate of the Administrator, may apply the cash, in whole or in part, to the satisfaction of any penalties for violations of 49 U.S.C. 30112 and 49 U.S.C. 32506 arising by reason of default.

[58 FR 12908, Mar. 8, 1993, as amended at 59 FR 52097, Oct. 14, 1994]

APPENDIX A TO PART 591—SECTION 591.5(f) BOND FOR THE ENTRY OF A SINGLE VEHICLE

Department of Transportation
National Highway Traffic Safety
Administration

BOND TO ENSURE CONFORMANCE WITH FEDERAL MOTOR VEHICLE SAFETY AND BUMPER STANDARDS

(To redeliver vehicle, to produce documents, to perform conditions of release such as to bring vehicle into conformance with all applicable Federal motor vehicle safety and bumper standards)

Know All Men by These Presents That (principal's name, mailing address which includes city, state, ZIP code, and state of incorporation if a corporation), as principal, and (surety's name, mailing address which includes city, state, ZIP code and state of incorporation), as surety, are held and firmly bound unto the UNITED STATES OF AMERICA in the sum of (bond amount in words) dollars (\$ (bond amount in numbers)), which represents 150% of the entered value of the following described motor vehicle, as determined by the Bureau of Customs and Border Protection: (make, model, model year, and VIN) for the payment of which we bind ourselves, our heirs, executors, and assigns (jointly and severally), firmly bound by these presents.

WITNESS our hands and seals this ____ day of ____, 20__.

WHEREAS, motor vehicles may be entered under the provisions of 49 U.S.C. Chapters 301 and 325; and DOT Form HS-7 "Declaration;"

WHEREAS, pursuant to 49 CFR part 591, a regulation promulgated under the provisions of 49 U.S.C. Chapter 301, the above-bounden principal desires to import permanently the motor vehicle described above, which is a motor vehicle that was not originally manufactured to conform to the Federal motor vehicle safety or bumper standards; and

WHEREAS, pursuant to 49 CFR part 592, a regulation promulgated under the provisions of 49 U.S.C. Chapter 301, the above-bounden principal has been granted the status of Registered Importer of motor vehicles not originally manufactured to conform to the Federal motor vehicle safety and bumper standards (or, if not a Registered Importer, has a contract with a Registered Importer covering the vehicle described above); and

WHEREAS, pursuant to 49 CFR part 593, a regulation promulgated under 49 U.S.C. Chapter 301, the Administrator of the National Highway Traffic Safety Administration has decided that the motor vehicle described above is eligible for importation into the United States; and

WHEREAS, the motor vehicle described above has been imported at the port of _____, and entered at said port for consumption on entry No._____, dated_____, 20__;

NOW, THEREFORE, THE CONDITION OF THIS OBLIGATION IS SUCH THAT—

(1) The above-bounden principal (the "principal"), in consideration of the permanent admission into the United States of the motor vehicle described above (the "vehicle"), voluntarily undertakes and agrees to have such vehicle brought into conformity with all applicable Federal motor vehicle safety and bumper standards within a rea-

sonable time after such importation, as specified by the Administrator of the National Highway Traffic Safety Administration (the "Administrator");

(2) The principal shall then file, or if not a Registered Importer, shall then cause the Registered Importer of the vehicle to file, with the Administrator, a certificate that the vehicle complies with each Federal motor vehicle safety standard in the year that the vehicle was manufactured and which applies in such year to the vehicle, and that the vehicle complies with the Federal bumper standard (if applicable);

(3) The principal, if a Registered Importer, shall not release custody of the vehicle to any person for license or registration for use on public roads, streets, or highways, or license or register the vehicle from the date of entry until 30 calendar days after it has certified compliance of the vehicle to the Administrator, unless the Administrator notifies the principal before 30 calendar days that (s)he has accepted such certification and the vehicle and bond may be released, except that no such release shall be permitted, before or after the 30th calendar day, if the principal has received written notice from the Administrator that an inspection of such vehicle will be required, or that there is reason to believe that such certification is false or contains a misrepresentation.

(4) And if the principal has received written notice from the Administrator that an inspection is required, the principal shall cause the vehicle to be available for inspection, and the vehicle and bond shall be promptly released after completion of an inspection showing no failure to comply. However, if the inspection shows a failure to comply, the vehicle and bond shall not be released until such time as the failure to comply ceases to exist;

(5) And if the principal has received written notice from the Administrator that there is reason to believe that the certificate is false or contains a misrepresentation, the vehicle or bond shall not be released until the Administrator is satisfied with the certification and any modification thereof;

(6) And if the principal has received written notice from the Administrator that the vehicle has been found not to comply with all applicable Federal motor vehicle safety and bumper standards, and written demand that the vehicle be abandoned to the United States, or delivered to the Secretary of Homeland Security for export (at no cost to the United States), the principal shall abandon the vehicle to the United States, or shall deliver the vehicle, or cause the vehicle to be delivered to, the custody of the Bureau of Customs and Border Protection at the port of entry listed above, or any other port of entry, and shall execute all documents necessary for exportation of the vehicle from the United States, at no cost to the United

States; or in default of abandonment or redelivery after proper notice by the Administrator to the principal, the principal shall pay to the Administrator the amount of this obligation;

Then this obligation shall be void; otherwise it shall remain in full force and effect. Signed, sealed, and delivered in the presence of—

Name Address
(Principal) (SEAL)

Name Address

Name Address
(Surety) (SEAL)

Name Address

CERTIFICATE AS TO CORPORATE PRINCIPAL

I, _____ certify that I am the _____ of the corporation named as principal in the within bond; that _____, who signed the bond on behalf of the principal, was then _____ of said corporation; that I know his/her signature, and his/her signature thereto is genuine; and that said bond was duly signed, sealed, and attested for and in behalf of said corporation by authority of its governing body.

[Corporate Seal]

To be used when a power of attorney has been filed with NHTSA. May be executed by secretary, assistant secretary, or other officer.

[55 FR 11380, Mar. 28, 1990, as amended at 59 FR 52097, Oct. 14, 1994; 69 FR 52093, Aug. 24, 2004]

APPENDIX B TO PART 591—SECTION 591.5(f) BOND FOR THE ENTRY OF MORE THAN A SINGLE VEHICLE

DEPARTMENT OF TRANSPORTATION

NATIONAL HIGHWAY TRAFFIC SAFETY ADMINISTRATION

BOND TO ENSURE CONFORMANCE WITH FEDERAL MOTOR VEHICLE SAFETY AND BUMPER STANDARDS

(To redeliver vehicles, to produce documents, to perform conditions of release such as to bring vehicles into conformance with all applicable Federal motor vehicle safety and bumper standards)

Know All Men by These Presents That (principal's name, mailing address which in-

cludes city, state, ZIP code, and state of incorporation if a corporation), as principal, and (surety's name, mailing address which includes city, state, ZIP code and state of incorporation) as surety, are held and firmly bound unto the UNITED STATES OF AMERICA in the sum of (bond amount in words) dollars (\$ (bond amount in numbers)), which represents 150% of the entered value of the following described motor vehicle, as determined by the Bureau of Customs and Border Protection (make, model, model year, and VIN of each vehicle) for the payment of which we bind ourselves, our heirs, executors, and assigns (jointly and severally), firmly bound by these presents.

WITNESS our hands and seals this ____ day of _____, 20 ____.

WHEREAS, motor vehicles may be entered under the provisions of 49 U.S.C. Chapters 301 and 325; and DOT Form HS-7 "Declaration,"

WHEREAS, pursuant to 49 CFR part 591, a regulation promulgated under the provisions of 49 U.S.C. Chapter 301, the above-bounden principal desires to import permanently the motor vehicles described above, which are motor vehicles that were not originally manufactured to conform to the Federal motor vehicle safety, or bumper, or theft prevention standards; and

WHEREAS, pursuant to 49 CFR part 592, a regulation promulgated under the provisions of 49 U.S.C. Chapter 301, the above-bounden principal has been granted the status of Registered Importer of motor vehicles not originally manufactured to conform to the Federal motor vehicle safety, bumper, and theft prevention standards; and

WHEREAS, pursuant to 49 CFR part 593, a regulation promulgated under 49 U.S.C. Chapter 301, the Administrator of the National Highway Traffic Safety Administration has decided that each motor vehicle described above is eligible for importation into the United States; and

WHEREAS, the motor vehicles described above have been imported at the port of _____, and entered at said port for consumption on entry No. _____, dated _____, 20 ____;

NOW, THEREFORE, THE CONDITION OF THIS OBLIGATION IS SUCH THAT—

(1) The above-bounden principal ("the principal"), in consideration of the permanent admission into the United States of the motor vehicles described above, voluntarily undertakes and agrees to have such vehicles brought into conformity with all applicable Federal motor vehicle safety and bumper standards within a reasonable time after such importation, as specified by the Administrator of the National Highway Traffic Safety Administration (the "Administrator");

(2) For each vehicle described above ("such vehicle"), the principal shall then file, with the Administrator, a certificate that such vehicle complies with each Federal motor vehicle safety standard in the year that such vehicle was manufactured and which applies in such year to such vehicle, and that such vehicle complies with the Federal bumper standard (if applicable);

(3) The principal shall not release custody of any vehicle to any person, or license or register the vehicle, from the date of entry until 30 calendar days after it has certified compliance of such vehicle to the Administrator, unless the Administrator notifies the principal before 30 days that (s)he has accepted such certification and such vehicle and all liability under this bond for such vehicle may be released, except that no such release shall be permitted, before or after the 30th calendar day, if the principal has received written notice from the Administrator that an inspection of such vehicle will be required, or that there is reason to believe that such certification is false or contains a misrepresentation.

(4) And if the principal has received written notice from the Administrator that an inspection of such vehicle is required, the principal shall cause such vehicle to be available for inspection, and such vehicle and all liability under this bond for such vehicle shall be promptly released after completion of an inspection showing no failure to comply. However, if the inspection shows a failure to comply, such vehicle and all liability under this bond for such vehicle shall not be released until such time as the failure to comply ceases to exist;

(5) And if the principal has received written notice from the Administrator that there is reason to believe that such certificate is false or contains a misrepresentation, such vehicle and all liability under this bond for such vehicle shall not be released until the Administrator is satisfied with such certification and any modification thereof;

(6) And if the principal has received written notice from the Administrator that such vehicle has been found not to comply with all applicable Federal motor vehicle safety and bumper standards, and written demand that such vehicle be abandoned to the United States, or delivered to the Secretary of Homeland Security for export (at no cost to the United States), the principal shall abandon such vehicle to the United States, or shall deliver such vehicle, or cause such vehicle to be delivered to, the custody of the Bureau of Customs and Border Protection at the port of entry listed above, or any other port of entry, and shall execute all documents necessary for exportation of such vehicle from the United States, at no cost to the United States; or in default of abandonment or redelivery after proper notice by the Administrator to the principal, the principal

shall pay to the Administrator an amount equal to 150% of the entered value of such vehicle as determined by the Bureau of Customs and Border Protection;

Then this obligation shall be void; otherwise it shall remain in full force and effect. [At this point the terms agreed upon between the principal and surety for termination of the obligation may be entered]

Signed, sealed and delivered in the presence of

PRINCIPAL: (name and address)

(Signature) (SEAL)

(Printed name and title)

SURETY: (name and address)

(Signature)

(Printed name and title)

[60 FR 57954, Nov. 24, 1995, as amended at 69 FR 52093, Aug. 24, 2004]

APPENDIX C TO PART 591—POWER OF ATTORNEY AND AGREEMENT

_____ does constitute and appoint the Administrator of the National Highway Traffic Safety Administration, United States Department of Transportation, or delegate, as attorney for the undersigned, for and in the name of the undersigned to collect or to sell, assign, and transfer the securities described below as follows:

- Title
Matures
Int. Rate
Denom.
Serial #
Coupon/registered

The securities having been deposited by it as security for the performance of the agreements undertaken in a bond with the United States, executed on the date of _____, the terms and conditions of which are incorporated by reference into this power of attorney and agreement and made a part hereof. The undersigned agrees that in case of any default in the performance of any of the agreements the attorney shall have full power to collect the securities or any part thereof, or to sell, assign, and transfer the securities or any part thereof, or to sell, assign, and transfer the securities of any part thereof at public or private sale, without notice, free from any equity of redemption and without appraisalment or valuation, notice

and right to redeem being waived and to apply the proceeds of the sale or collection in whole or in part to the satisfaction of any obligation arising by reason of default. The undersigned further agrees that the authority granted by this agreement is irrevocable. The undersigned ratifies and confirms whatever the attorney shall do by virtue of this agreement.

Witnessed and signed this _____ day of _____, _____.

Before me, the undersigned, a notary public within and for the County of _____ in the State of _____, personally appeared _____ and acknowledged the execution of the foregoing power of attorney.

Witness my hand and notarial seal this _____ day of _____, 199__.

[Notarial seal]

Notary Public _____

[58 FR 12909, Mar. 8, 1993]

PART 592—REGISTERED IMPORTERS OF VEHICLES NOT ORIGINALLY MANUFACTURED TO CONFORM TO THE FEDERAL MOTOR VEHICLE SAFETY STANDARDS

Sec.

592.1 Scope.

592.2 Purpose.

592.3 Applicability.

592.4 Definitions.

592.5 Requirements for registration and its maintenance.

592.6 Duties of a registered importer.

592.7 Suspension, revocation, and reinstatement of suspended registration.

592.8 Inspection; release of vehicle and bond.

592.9 Forfeiture of bond.

AUTHORITY: Pub. L. 100-562, 49 U.S.C. 322(a), 30117, 30141-30147; delegation of authority at 49 CFR 1.50.

SOURCE: 54 FR 40090, Sept. 29, 1989, unless otherwise noted.

§ 592.1 Scope.

This part establishes procedures under 49 U.S.C. 30141(c) for the registration of importers of motor vehicles that were not originally manufactured to comply with all applicable Federal motor vehicle safety standards. This part also establishes the duties of Registered Importers.

[59 FR 52098, Oct. 14, 1994]

§ 592.2 Purpose.

The purpose of this part is to provide content and format requirements for persons who wish to register with the Administrator as importers of motor vehicles not originally manufactured to conform to all applicable Federal motor vehicle safety standards, to provide procedures for the registration of importers and for the suspension, revocation and reinstatement of registration, and to set forth the duties required of Registered Importers.

§ 592.3 Applicability.

This part applies to any person who wishes to register with the Administrator as an importer of nonconforming vehicles, and to any person who is registered as an importer.

§ 592.4 Definitions.

All terms in this part that are defined in 49 U.S.C. 30102 and 30125 are used as defined therein.

Administrator means the Administrator, National Highway Traffic Safety Administration.

Independent insurance company means an entity that is registered with any State and authorized by that State to conduct an insurance business including the issuance or underwriting of a service insurance policy, none of whose affiliates, shareholders, officers, directors, or employees, or any person in affinity with such, is employed by, or has a financial interest in, or otherwise controls or participates in the business of, a Registered Importer to which it issues or underwrites a service insurance policy.

NHTSA means the National Highway Traffic Safety Administration.

Principal, with respect to a Registered Importer, means any officer of a corporation, a general partner of a partnership, or the sole proprietor of a sole proprietorship. The term includes a director of an incorporated Registered Importer, and any person whose ownership interest in a Registered Importer is 10% or more.

Registered Importer means any person that the Administrator has registered as an importer pursuant to section 592.5(b).

Safety recall means a notification and remedy campaign conducted pursuant

to 49 U.S.C. 30118-30120 to address a noncompliance with a Federal motor vehicle safety standard or a defect that relates to motor vehicle safety.

Service insurance policy means any policy issued or underwritten by an independent insurance company which covers a specific motor vehicle and guarantees that any noncompliance with a Federal motor vehicle safety standard or defect related to motor vehicle safety determined to exist in that vehicle will be remedied without charge to the owner of the vehicle.

[54 FR 40090, Sept. 29, 1989, as amended at 59 FR 52098, Oct. 14, 1994; 69 FR 52094, Aug. 24, 2004]

§ 592.5 Requirements for registration and its maintenance.

(a) Any person wishing to register as an importer of motor vehicles not originally manufactured to conform to all applicable Federal motor vehicle safety standards must file an application which:

(1) Is headed with the words "Application for Registration as Importer", and submitted in three copies to: Administrator, National Highway Traffic Safety Administration, Room 6115, 400 7th Street SW., Washington, DC 20590, Attn: NEF-32 Importer Registration.

(2) Is written in the English language.

(3) Sets forth the full name, street address, and title of the person preparing the application, and the full name, street address, e-mail address (if any), and telephone and facsimile machine (if any) numbers in the United States of the person for whom application is made (the "applicant").

(4) Specifies the form of the applicant's organization (*i.e.*, sole proprietorship, partnership, or corporation) and the State under which it is organized, and:

(i) If the applicant is an individual, the application must include the full name, street address, and date of birth of the individual.

(ii) If the applicant is a partnership, the application must include the full name, street address, and date of birth of each partner; if one or more of the partners is a limited partnership, the application must include the names and street addresses of the general

partners and limited partners; if one or more of the partners is a corporation, the application must include the information specified by either paragraph (a)(4)(iii) or (iv) of this section, as applicable;

(iii) If the applicant is a non-public corporation, the application must include the full name, street address, and date of birth of each officer, director, manager, and person who is authorized to sign documents on behalf of the corporation. The application must also include the name of any person who owns or controls 10 percent or more of the corporation. The applicant must also provide a statement issued by the Office of the Secretary of State, or other responsible official of the State in which the applicant is incorporated, certifying that the applicant is a corporation in good standing;

(iv) If the applicant is a public corporation, the applicant must include a copy of its latest 10-K filing with the Securities and Exchange Commission, and provide the name and address of any person who is authorized to sign documents on behalf of the corporation;

(v) Contains a statement that the applicant has never had a registration revoked pursuant to § 592.7, nor is it, nor was it, directly or indirectly, owned or controlled by, or under common ownership or control with, a Registered Importer that has had a registration revoked pursuant to § 592.7; and

(vi) Identifies any shareholder, officer, director, employee, or any person in affinity with such, who has been previously affiliated with another Registered Importer in any capacity. If any such persons are identified, the applicant shall state the name of each such Registered Importer and the affiliation of any identified person.

(5) Includes the following:

(i) The street address and telephone number in the United States of each of its facilities for conformance, storage, and repair that the applicant will use to fulfill its duties as a Registered Importer and where the applicant will maintain the records it is required by this part to keep;

(ii) The street address that the applicant designates as its mailing address (in addition, an applicant may list a

§ 592.5

49 CFR Ch. V (10–1–10 Edition)

post office box, provided that it is in the same city as the street address designated as its mailing address);

(iii) A copy of the applicant's business license or other similar document issued by an appropriate State or local authority, authorizing it to do business as an importer, or modifier, or seller of motor vehicles, as applicable to the applicant and with respect to each facility that the applicant has identified pursuant to paragraph (a)(5)(i) of this section, or a statement by the applicant that it has made a bona fide inquiry and is not required by such State or local authority to have such a license or document;

(iv) The name of each principal of the applicant whom the applicant authorizes to submit conformity certifications to NHTSA and the street address of the repair, storage, or conformance facility where each such principal will be located; and

(v) If an applicant is a corporation not organized under the laws of a State of the United States, or is a sole proprietorship or partnership located outside the United States, the application must be accompanied by the applicant's designation of an agent for service of process in the form specified by Section 551.45 of this chapter.

(6) Contains a statement that the applicant has never had a registration revoked pursuant to § 592.7, nor is it or was it, directly or indirectly, owned or controlled by, or under common ownership or control with, a person who has had a registration revoked pursuant to § 592.7.

(7) Contains a certified check payable to the Treasurer of the United States, for the amount of the initial annual fee established pursuant to part 594 of this chapter.

(8) Contains a copy of a contract to acquire, effective upon its registration as an importer, a prepaid mandatory service insurance policy underwritten by an independent insurance company, or a copy of such policy, in an amount that equals \$2,000 for each motor vehicle for which the applicant will furnish a certificate of conformity to the Administrator, for the purpose of ensuring that the applicant will be able financially to remedy any noncompliance or safety related defect deter-

mined to exist in any such motor vehicle in accordance with part 573 and part 577 of this chapter. If the application is accompanied by a copy of a contract to acquire such a policy, the applicant shall provide NHTSA with a copy of the policy within 10 days after it has been issued to the applicant.

(9) Sets forth in full complete descriptive information, views, and arguments sufficient to establish that the applicant:

(i) Is technically able to modify any nonconforming motor vehicle to conform to all applicable Federal motor vehicle safety and bumper standards, including but not limited to the professional qualifications of the applicant and its employees at the time of the application (such as whether any such persons have been certified as mechanics), and a description of their experience in conforming and repairing vehicles;

(ii) Owns or leases one or more facilities sufficient in nature and size to repair, conform, and store the vehicles for which it provides certification of conformance to NHTSA and which it imports and may hold pending release of conformance bonds, including a copy of a deed or lease evidencing ownership or tenancy for each such facility, still or video photographs of each such facility, the street address and telephone number of each such facility;

(iii) Is financially and technically able to provide notification of and to remedy a noncompliance with a Federal motor vehicle safety standard or a defect related to motor vehicle safety determined to exist in the vehicles that it imports and/or for which it provides certification of conformity to NHTSA through repair, repurchase or replacement of such vehicles; and

(iv) Is able to acquire and maintain information regarding the vehicles that it imported and the names and addresses of owners of the vehicles that it imported and/or for which it provided certifications of conformity to NHTSA in order to notify such owners when a noncompliance or a defect related to motor vehicle safety has been determined to exist in such vehicles.

(10) Segregates and specifies any part of the information and data submitted under this part that the applicant

wishes to have withheld from public disclosure in accordance with part 512 of this chapter.

(11) Contains the statement: "I certify that I have read and understood the duties of a Registered Importer, as set forth in 49 CFR 592.6, and that [name of applicant] will fully comply with each such duty. I further certify that all the information provided in this application is true and correct. I further certify that I understand that, in the event the registration for which it is applying is suspended or revoked, or lapses, [name of applicant] will remain obligated to notify owners and to remedy noncompliances or safety related defects, as required by 49 CFR 592.6(j), for each vehicle for which it has furnished a certificate of conformity to the Administrator."

(12) Has the applicant's signature acknowledged by a notary public.

(b) If the application is incomplete, the Administrator notifies the applicant in writing of the information that is needed for the application to be complete and advises that no further action will be taken on the application until the applicant has furnished all the information needed.

(c) If the Administrator deems it necessary for a determination upon the application, NHTSA conducts an inspection of the applicant. Subsequent to the inspection, NHTSA calculates the costs attributable to such inspection, and notifies the applicant in writing that such costs comprise a component of the initial annual fee and must be paid before a determination is made upon its application.

(d) When the application is complete (and, if applicable, when the applicant has paid a sum representing the inspection component of the initial annual fee), the Administrator reviews the application and decides whether the applicant has complied with the requirements prescribed in paragraph (a) of this section. The Administrator shall base this decision on the application and upon any inspection NHTSA may have conducted of the applicant's conformance, storage, and recordkeeping facilities and any assessment of the applicant's personnel. If the Administrator decides that the applicant complies with the requirements, (s)he in-

forms the applicant in writing and issues it a Registered Importer Number.

(e)(1) The Administrator shall deny registration to any applicant who (s)he decides does not comply with the requirements of paragraph (a) of this section and to an applicant whose previous registration has been revoked. The Administrator also may deny registration to an applicant that is or was owned or controlled by, or under common ownership or control with, or in affinity with, a Registered Importer whose registration has been revoked. In determining whether to deny an application, the Administrator may consider whether the applicant is comprised in whole or in part of relatives, employees, major shareholders, partners, or relatives of former partners or major shareholders, of a Registered Importer whose registration was revoked.

(2) If the Administrator denies an application, (s)he informs the applicant in writing of the reasons for denial and that the applicant is entitled to a refund of that component of the initial annual fee representing the remaining costs of administration of the registration program, but not those components of the initial annual fee representing the costs of processing the application, and, if applicable, the costs of conducting an inspection of the applicant's facilities.

(3) Within 30 days from the date of the denial, the applicant may submit a petition for reconsideration. The applicant may submit information and/or documentation supporting its request. If the Administrator grants registration as a result of the request, (s)he notifies the applicant in writing and issues it a Registered Importer Number. If the Administrator denies registration, (s)he notifies the applicant in writing and refunds that component of the initial annual fee representing the remaining costs of administration of the registration program, but does not refund those components of the initial annual fee representing the costs of processing the application, and, if applicable, the costs of conducting an inspection.

(f) In order to maintain its registration, a Registered Importer must file an annual statement. The Registered

§ 592.6

49 CFR Ch. V (10–1–10 Edition)

Importer must affirm in its annual statement that all information provided in its application or pursuant to § 592.6(q), or as may have been changed in any notification that it has provided to the Administrator in compliance with § 592.6(l), remains correct, and that it continues to comply with the requirements for being a Registered Importer. The Registered Importer must include with its annual statement a current copy of its service insurance policy. Such statement must be titled “Yearly Statement of Registered Importer,” and must be filed not later than September 30 of each year. A Registered Importer must also pay any annual fee, and any other fee that is established under part 594 of this chapter. An annual fee must be paid not later than September 30 of any calendar year for the fiscal year that begins on October 1 of that calendar year. The Registered Importer must pay any other fee not later than 15 days after the date of the written notice from the Administrator.

(g) A registration granted under this part is not transferable.

(h) An applicant whose application is pending on September 30, 2004, and which has not provided the information required by paragraph (a) of this section, as amended, must provide all the information required by that subsection before the Administrator will give further consideration to the application.

[54 FR 40090, Sept. 29, 1989, as amended at 54 FR 47088, Nov. 9, 1989; 55 FR 37330, Sept. 11, 1990; 69 FR 52094, Aug. 24, 2004; 70 FR 57801, Oct. 4, 2005]

§ 592.6 Duties of a registered importer.

Each Registered Importer must:

(a) With respect to each motor vehicle that it imports into the United States, assure that the Administrator has decided that the vehicle is eligible for importation pursuant to part 593 of this chapter, prior to such importation. The Registered Importer must also bring such vehicle into conformity with all applicable Federal motor vehicle safety standards prescribed under part 571 of this chapter and the bumper standard prescribed under part 581 of this chapter, if applicable, and furnish certification to the Administrator pur-

suant to paragraph (e) of this section, within 120 calendar days after such entry. For each motor vehicle, the Registered Importer must furnish to the Secretary of Homeland Security at the time of importation a bond in an amount equal to 150 percent of the dutiable value of the vehicle, as determined by the Secretary of Homeland Security, to ensure that such vehicle either will be brought into conformity with all applicable Federal motor vehicle safety and bumper standards or will be exported (at no cost to the United States) by the importer or the Secretary of Homeland Security or abandoned to the United States. However, if the Registered Importer has procured a continuous entry bond, it must furnish the Administrator with such bond, and must furnish the Secretary of Homeland Security (acting on behalf of the Administrator) with a photocopy of such bond and Customs Form CF 7501 at the time of importation of each motor vehicle.

(b) Establish, maintain, and retain, for 10 years from the date of entry, at the facility in the United States it has identified in its application pursuant to § 592.5 (a)(5)(i), for each motor vehicle for which it furnishes a certificate of conformity, the following records, including correspondence and other documents, in hard copy format:

(1) The declaration required by § 591.5 of this chapter.

(2) All vehicle or equipment purchase or sales orders or agreements, conformance agreements between the Registered Importer and persons who import motor vehicles for personal use, and correspondence between the Registered Importer and the owner or purchaser of the vehicle.

(3) The make, model, model year, odometer reading, and VIN of each vehicle that it imports and the last known name and address of the owner or purchaser of the vehicle.

(4) Records, including photographs and other documents, sufficient to identify the vehicle and to substantiate that it has been brought into conformity with all Federal motor vehicle safety and bumper standards that apply to the vehicle, that the certification label has been affixed, and that either the vehicle is not subject to any

safety recalls or that all noncompliances and safety defects covered by such recalls were remedied before the submission to the Administrator under paragraph (d) of this section. All photographs submitted shall be unaltered.

(5) A copy of the certification submitted to the Administrator pursuant to paragraph (d) of this section.

(6) The number that the issuer has assigned to the service insurance policy that will accompany the vehicle and the full corporate or other business name of the issuer of the policy, and substantiation that the Registered Importer has notified the issuer of the policy that the policy has been provided with the vehicle.

(c) Take possession of the vehicle and perform all modifications necessary to conform the vehicle to all Federal motor vehicle safety and bumper standards that apply to the vehicle at a facility that it has identified to the Administrator pursuant to § 592.5(a)(5)(i), and permanently affix to the vehicle at that facility, upon completion of conformance modifications and remedy of all noncompliances and defects that are the subject of any pending safety recalls, a label that identifies the Registered Importer and states that the Registered Importer certifies that the vehicle complies with all Federal motor vehicle safety and bumper standards that apply to the vehicle, and contains all additional information required by § 567.4 of this chapter.

(d) For each motor vehicle, certify to the Administrator:

(1) Within 120 days of the importation that it has brought the motor vehicle into conformity with all applicable Federal motor vehicle safety and bumper standards in effect at the time the vehicle was manufactured by the fabricating manufacturer. Such certification shall state verbatim either that "I know that the vehicle that I am certifying conforms with all applicable Federal motor vehicle safety and bumper standards because I personally witnessed each modification performed on the vehicle to effect compliance," or that "I know that the vehicle I am certifying conforms with all applicable Federal motor vehicle safety and bumper standards because the person

who performed the necessary modifications to the vehicle is an employee of [RI name] and has provided full documentation of the work that I have reviewed, and I am satisfied that the vehicle as modified complies." The Registered Importer shall also certify, as appropriate, that either:

(i) The vehicle is not required to comply with the parts marking requirements of the theft prevention standard (part 541 of this chapter); or

(ii) The vehicle complies with those parts marking requirements as manufactured, or as modified prior to importation.

(2) If the Registered Importer certifies that the vehicle was originally manufactured to comply with a standard that does not apply to the vehicle or that it has modified the vehicle to conform to such standard, or if the certification is incomplete, the Administrator may refuse to accept the certification. The Administrator shall refuse to accept a certification for a vehicle that has not been determined to be eligible for importation under part 593 of this chapter. If the Administrator does not accept a submission, (s)he shall return it to the Registered Importer. The costs associated with such a return will be charged to the Registered Importer. If the Administrator returns the submission as described above and the vehicle is eligible for importation, the 120-day period specified in paragraph (d)(1) of this section continues to run, but the 30-day period specified in paragraph (f) of this section does not begin to run until the Administrator has accepted the submission. If the vehicle is not eligible for importation, the importer must export it from, or abandon it to, the United States. If the Registered Importer certifies that it has modified the vehicle to bring it into compliance with a standard and has, in fact, not performed all required modifications, the Administrator will regard such certification as "knowingly false" within the meaning of 49 U.S.C. 30115 and 49 U.S.C. 30141(c)(4)(B).

(3) The certification must be signed and submitted by a principal of the Registered Importer designated in its registration application pursuant to § 592.5(a)(5)(iv), with an original hand-

§592.6

49 CFR Ch. V (10–1–10 Edition)

written signature and not with a signature that is stamped or mechanically applied.

(4) The certification to the Administrator must specify the location of the facility where the vehicle was conformed, and the location where the Administrator may inspect the motor vehicle.

(5) The certification to the Administrator must state and contain substantiation either that the vehicle is not subject to any safety recalls as of the time of such certification, or, alternatively, that all noncompliances and defects that are the subject of those safety recalls have been remedied.

(6) When a Registered Importer certifies a make, model, and model year of a motor vehicle for the first time, its certification must include:

(i) The make, model, year and date of manufacture, odometer reading, VIN that complies with §565.4(b), (c), and (g) of this chapter, and Customs Entry Number,

(ii) A statement that it has brought the vehicle into conformity with all Federal motor vehicle safety and bumper standards that apply to the vehicle, and a description, with respect to each standard for which modifications were needed, of the modifications performed,

(iii) A copy of the bond given at the time of entry to ensure conformance with the safety and bumper standards,

(iv) The vehicle's vehicle eligibility number, as stated in appendix A to part 593 of this chapter,

(v) A copy of the HS-7 Declaration form executed at the time of its importation if a Customs broker did not make an electronic entry for the vehicle with the Bureau of Customs and Border Protection,

(vi) Unaltered front, side, and rear photographs of the vehicle,

(vii) Unaltered photographs of the original manufacturer's certification label and the certification label of the Registered Importer affixed to the vehicle (and, if the vehicle is a motorcycle, a photograph or photocopy of the Registered Importer certification label before it has been affixed),

(viii) Unaltered photographs and documentation sufficient to demonstrate conformity with all applicable Federal

motor vehicle safety and bumper standards to which the vehicle was not originally manufactured to conform,

(ix) The policy number of the service insurance policy furnished with the vehicle pursuant to paragraph (g) of this section, and the full corporate or other business name of the insurer that issued the policy, and

(x) A statement that the submission is the Registered Importer's initial certification submission for the make, model, and model year of the vehicle covered by the certification.

(7) Except as specified in this paragraph, a Registered Importer's second and subsequent certification submissions for a given make, model, and model year vehicle must contain the information required by paragraph (d)(6) of this section. If the Registered Importer conformed such a vehicle in the same manner as it stated in its initial certification submission, it may say so in a subsequent submission and it need not provide the description required by paragraph (d)(6)(ii) of this section.

(e) With respect to each motor vehicle that it imports, not take any of the following actions until the bond referred to in paragraph (a) of this section has been released, unless 30 days have elapsed from the date the Administrator receives the Registered Importer's certification of compliance of the motor vehicle in accordance with paragraph (d) of this section (the 30-day period will be extended if the Administrator has made written demand to inspect the motor vehicle):

(1) Operate the motor vehicle on the public streets, roads, and highways for any purpose other than:

(i) Transportation to and from a franchised dealership of the vehicle's original manufacturer for remedying a non-compliance or safety-related defect; or

(ii) Mileage accumulation to stabilize the vehicle's catalyst and emissions control systems in preparation for pre-certification testing to obtain an Environmental Protection Agency (EPA) certificate of conformity, but only insofar as the vehicle has been imported by an Independent Commercial Importer (ICI) who holds a current certificate of conformity with the EPA, the ICI has imported the vehicle under an

EPA Declaration form 3520-1 on which Code J is checked, and the EPA has granted the ICI written permission to operate the vehicle on public roads for that purpose.

(2) Sell the motor vehicle or offer it for sale;

(3) Store the motor vehicle on the premises of a motor vehicle dealer;

(4) Title the motor vehicle in a name other than its own, or license or register it for use on public streets, roads, or highways; or

(5) Release custody of the motor vehicle to a person for sale, or for license or registration for use on public streets, roads, and highways, or for titling in a name other than that of the Registered Importer who imported the vehicle.

(f) Furnish with each motor vehicle for which it furnishes certification or information to the Administrator in accordance with paragraph (d) of this section, not later than the time it sells the vehicle, or releases custody of a vehicle to an owner who has imported it for personal use, a service insurance policy written or underwritten by an independent insurance company, in the amount of \$2,000. The Registered Importer shall provide the insurance company with a monthly list of the VINs of vehicles covered by the policies of the insurance company, and shall retain a copy of each such list in its files.

(g) Comply with the requirements of part 580 of this chapter, *Odometer Disclosure Requirements*, when the Registered Importer is a transferor of a vehicle as defined by § 580.3 of this chapter.

(h) With respect to any motor vehicle it has imported and for which it has furnished a performance bond, deliver such vehicle to the Secretary of Homeland Security for export, or abandon it to the United States, upon demand by the Administrator, if such vehicle has not been brought into conformity with all applicable Federal motor vehicle safety and bumper standards within 120 days from entry.

(i)(1) With respect to any motor vehicle that it has imported or for which it has furnished a certificate of conformity or information to the Administrator as provided in paragraph (d) of this section, provide notification in ac-

cordance with part 577 of this chapter and a remedy without charge to the vehicle owner, after any notification under part 573 of this chapter that a vehicle to which such motor vehicle is substantially similar contains a defect related to motor vehicle safety or fails to conform with an applicable Federal motor vehicle safety standard. However, this obligation does not exist if the manufacturer of the vehicle or the Registered Importer of such vehicle demonstrates to the Administrator that the defect or noncompliance is not present in such vehicle, or that the defect or noncompliance was remedied before the submission of the certificate or the information to the Administrator, or that the original manufacturer of the vehicle will provide such notification and remedy.

(2) If a Registered Importer becomes aware (from whatever source) that the manufacturer of a vehicle it has imported will not provide a remedy without charge for a defect or noncompliance that has been determined to exist in that vehicle, within 30 days thereafter, the Registered Importer must inform NHTSA and submit a copy of the notification letter that it intends to send to owners of the vehicle(s) in question.

(3) Any notification to vehicle owners sent by a Registered Importer must contain the information specified in § 577.5 of this chapter, and must include the statement that if the Registered Importer's repair facility is more than 50 miles from the owner's mailing address, remedial repairs may be performed at no charge at a specific facility designated by the Registered Importer that is within 50 miles of the owner's mailing address, or, if no such facility is designated, that repairs may be performed anywhere, with the cost of parts and labor to be reimbursed by the Registered Importer.

(4) Defect and noncompliance notifications by a Registered Importer must conform to the requirements of §§ 577.7 and 577.8 of this chapter, and are subject to §§ 577.9 and 577.10 of this chapter.

(5) Except as provided in this paragraph, instead of the six quarterly reports required by § 573.7(a) of this chapter, the Registered Importer must submit to the Administrator two reports

§592.6

49 CFR Ch. V (10–1–10 Edition)

containing the information specified in §573.7(b)(1) through (4) of this chapter. The reports shall cover the periods ending nine and 18 months after the commencement of the owner notification campaign, and must be submitted within 30 days of the end of each period. However, the reporting requirements established by this paragraph shall not apply to any safety recall that a vehicle manufacturer conducts that includes vehicles for which the Registered Importer has submitted the information required by paragraph (d) of this section.

(6) The requirement that the remedy be provided without charge does not apply if the motor vehicle was bought by its first purchaser from the Registered Importer (or, if imported for personal use, conformed pursuant to a contract with the Registered Importer) more than 10 calendar years before the date the Registered Importer or the original manufacturer notifies the Administrator of the noncompliance or safety-related defect pursuant to part 573 of this chapter.

(j) In order that the Administrator may determine whether the Registered Importer is meeting its statutory responsibilities, allow representatives of NHTSA during operating hours, upon demand, and upon presentation of credentials, to copy documents, or to inspect, monitor, or photograph any of the following:

(1) Any facility identified by the Registered Importer where any vehicle for which a Registered Importer has the responsibility of providing a certificate of conformity to the Administrator is being modified, repaired, tested, or stored, and any facility where any record or other document relating to the modification, repair, testing, or storage of these vehicles is kept;

(2) Any part or aspect of activities relating to the modification, repair, testing, or storage of vehicles by the Registered Importer; and

(3) Any motor vehicle for which the Registered Importer has provided a certification of conformity to the Administrator before the Administrator releases the conformance bond.

(k) Provide an annual statement and pay an annual fee as required by §592.5(f).

(1) Except as noted in this paragraph, notify the Administrator in writing of any change that occurs in the information which was submitted in its registration application, not later than the 30th calendar day after such change. If a Registered Importer intends to use a facility that was not identified in its registration application, not later than 30 days before it begins to use such facility, it must notify the Administrator of its intent to use such facility and provide a description of the intended use, a copy of the lease or deed evidencing the Registered Importer's ownership or tenancy of the facility, and a copy of the license or similar document issued by an appropriate state or municipal authority stating that the Registered Importer is licensed to do business at that facility as an importer and/or modifier and/or seller of motor vehicles (or a statement that it has made a *bona fide* inquiry and is not required by state or local law to have such a license or permission), and a sufficient number of unaltered photographs of that facility to fully depict the Registered Importer's intended use. If a Registered Importer intends to change its street address or telephone number or discontinue use of a facility that was identified in its registration application, it shall notify the Administrator not less than 10 days before such change or discontinuance of such use, and identify the facility, if any, that will be used instead.

(m) Assure that at least one full-time employee of the Registered Importer is present at at least one of the Registered Importer's facilities in the United States during normal business hours.

(n) Not co-utilize the same employee, or any repair or conformance facility, with any other Registered Importer. If a Registered Importer co-utilizes the same storage facility with another Registered Importer or another entity, the storage area of each Registered Importer must be clearly delineated, and the vehicles being stored by each Registered Importer may not be mingled with vehicles for which that Registered Importer is not responsible.

(o) Make timely, complete, and accurate responses to any requests by the

Administrator for information, whether by general or special order or otherwise, to enable the Administrator to decide whether the Registered Importer has complied or is complying with 49 U.S.C. Chapters 301 and 325, and the regulations issued thereunder.

(p) Pay all fees either by certified check, cashier's check, money order, credit card, or Electronic Funds Transfer System made payable to the Treasurer of the United States, in accordance with the invoice of fees incurred by the Registered Importer in the previous month that is provided by the Administrator. All such fees are due and payable not later than 15 days from the date of the invoice.

(q) Not later than November 1, 2004, file with the Administrator all information required by § 592.5(a), as amended. If a Registered Importer has previously provided any item of information to the Administrator in its registration application, annual statement, or notification of change, it may incorporate that item by reference in the filing required under this subsection, provided that it clearly indicates the date, page, and entry of the previously-provided document.

[69 FR 52095, Aug. 24, 2004, as amended at 70 FR 57801, Oct. 4, 2005]

§ 592.7 Suspension, revocation, and reinstatement of suspended registrations.

This section specifies the acts and omissions that may result in suspensions and revocations of registrations issued to Registered Importers by NHTSA, the process for such suspensions and revocations, and the provisions applicable to the reinstatement of suspended registrations.

(a) *Automatic suspension of a registration.* 49 U.S.C. 30141(c)(4)(B) explicitly authorizes NHTSA to automatically suspend a registration when a Registered Importer does not, in a timely manner, pay a fee required by part 594 of this chapter or knowingly files a false or misleading certification under 49 U.S.C. 30146. NHTSA also may automatically suspend a registration under other circumstances, as specified in paragraphs (3), (4) and (5) of this section.

(1) If the Administrator has not received the annual fee from a Registered Importer by the close of business on October 10 of a year, or, if October 10 falls on a weekend or holiday, by the next business day thereafter, or has not received any other fee owed by a Registered Importer within 15 calendar days from the date of the Administrator's invoice, the Registered Importer's registration will be automatically suspended at the beginning of the next business day. The Administrator will promptly notify the Registered Importer in writing of the suspension. Such suspension shall remain in effect until reinstated pursuant to paragraph (c)(1) of this section.

(2) If the Administrator decides that a Registered Importer has knowingly filed a false or misleading certification, (s)he shall promptly notify the Registered Importer in writing that its registration is automatically suspended. The notification shall inform the Registered Importer of the facts and conduct upon which the decision is based, and the period of suspension (which begins as of the date indicated in the Administrator's written notification). The notification shall afford the Registered Importer an opportunity to seek reconsideration of the decision by presenting data, views, and arguments in writing and/or in person, within 30 days. Not later than 30 days after the submission of data, views, and arguments, the Administrator, after considering all the information available, shall notify the Registered Importer in writing of his or her decision on reconsideration. Any suspension issued under this paragraph shall remain in effect until reinstated pursuant to paragraph (c)(2) of this section.

(3) If mail is undeliverable to the Registered Importer at the official street address it has provided to the Administrator, or if the telephone has been disconnected at the telephone number specified by the Registered Importer, the Administrator may automatically suspend the Registered Importer's registration. Such suspension shall remain in effect until the registration is reinstated pursuant to paragraph (c)(3) of this section.

(4) If a Registered Importer, not later than November 1, 2004, does not file

with the Administrator all information required by § 592.5(a), as required by § 592.6(q), the Administrator may automatically suspend the registration. The Administrator shall promptly notify the Registered Importer in writing of the suspension. Such a suspension shall remain in effect until the registration is reinstated pursuant to paragraph (c)(4) of this section.

(5) If a Registered Importer releases one or more motor vehicles on the basis of a forged or falsified bond release letter, and the Administrator has not in fact issued such a letter, the Administrator may automatically suspend the registration. The Administrator shall promptly notify the Registered Importer in writing of the suspension.

(6) The Administrator, in his or her sole discretion, may provide notice of a proposed automatic suspension or revocation for reasons specified in paragraphs (a)(1) through (a)(5) of this section.

(7) The notification shall afford the Registered Importer an opportunity to seek reconsideration of the decision by presenting data, views, and arguments in writing and/or in person, within 30 days of such notification, before a decision, as provided in paragraph (b)(2) of this section. Not later than 30 days after the submission of data, views, and arguments, the Administrator, after considering all the information available, shall notify the Registered Importer in writing of his or her decision on reconsideration. Any automatic suspension issued under this paragraph shall remain in effect until reinstated pursuant to paragraph (c)(2) of this section.

(b) *Non-automatic suspension or revocation of a registration.* (1) 49 U.S.C. 30141(c)(4)(A) authorizes NHTSA to revoke or suspend a registration if a Registered Importer does not comply with a requirement of 49 U.S.C. 30141–30147, or any of 49 U.S.C. 30112, 30115, 30117–30122, 30125(c), 30127, or 30166, or any regulations issued under these sections. These regulations include, but are not limited to, parts 567, 568, 573, 577, 591, 593, and 594 of this chapter.

(2) When the Administrator has reason to believe that a Registered Importer has violated one or more of the

statutes or regulations cited in paragraph (b)(1) of this section and that suspension or revocation would be an appropriate sanction under the circumstances, (s)he shall notify the Registered Importer in writing of the facts giving rise to the allegation of a violation and the proposed length of a suspension, if applicable, or revocation. The notice shall afford the Registered Importer an opportunity to present data, views, and arguments, in writing and/or in person, within 30 days of the date of the notice, as to whether the violation occurred, why the registration ought not to be suspended or revoked, or whether the suspension should be shorter than proposed. If the Administrator decides, on the basis of the available information, that the Registered Importer has violated a statute or regulation, the Administrator may suspend or revoke the registration. The Administrator shall notify the Registered Importer in writing of the decision, including the reasons for it. A suspension or revocation is effective as of the date of the Administrator's written notification unless another date is specified therein. The Administrator shall state the period of any suspension in the notice to the Registered Importer. There shall be no opportunity to seek reconsideration of a decision issued under this paragraph.

(c) *Reinstatement of suspended registrations.* (1) When a registration has been suspended under paragraph (a)(1) of this section, the Administrator will reinstate the registration when all fees owing are paid by wire transfer or certified check from a bank in the United States, together with a sum representing 10 percent of the amount of the fees that were not timely paid.

(2) When a registration has been suspended under paragraph (a)(2) or (a)(5) of this section, the registration will be reinstated after the expiration of the period of suspension specified by the Administrator, or such earlier date as the Administrator may subsequently decide is appropriate.

(3) When a registration has been suspended under paragraph (a)(3) of this section, the registration will be reinstated when the Administrator decides that the Registered Importer has provided a street address to which mail to

it is deliverable and a telephone number in its name that is in service.

(4) When a registration has been suspended under paragraph (a)(4) of this section, the registration will be reinstated when the Administrator decides that the Registered Importer has provided all relevant documentation and information required by § 592.6(q).

(5) When a registration has been suspended under paragraph (b) of this section, the registration will be reinstated after the expiration of the period of suspension specified by the Administrator, or such earlier date as the Administrator may subsequently decide is appropriate.

(6) When a suspended registration has been reinstated, NHTSA shall notify the Bureau of Customs and Border Protection promptly.

(7) If a Registered Importer imports a motor vehicle on or after the date that its registration is suspended and before the date that the suspension ends, the Administrator may extend the suspension period by one day for each day that the Registered Importer has imported a motor vehicle during the time that its registration has been suspended.

(d) *Effect of suspension or revocation.*

(1) If a Registered Importer's registration is suspended or revoked, as of the date of suspension or revocation the entity will not be considered a Registered Importer, will not have the rights and authorities appertaining thereto, and must cease importing, and will not be allowed to import, vehicles for resale. The Registered Importer will not be refunded any annual or other fees it has paid for the fiscal year in which its registration is revoked. The Administrator shall notify the Bureau of Customs and Border Protection of any suspension or revocation of a registration not later than the first business day after such action is taken.

(2) With respect to any vehicle for which it has not affixed a certification label and submitted a certificate of conformity to the Administrator under § 592.6(d) at the time it is notified that its registration has been suspended or revoked, the Registered Importer must affix a certification label and submit a certificate of conformity within 120 days from the date of entry.

(3) When a registration has been revoked or suspended, the Registered Importer must export within 30 days of the effective date of the suspension or revocation all vehicles that it imported to which it has not affixed a certification label and furnished a certificate of conformity to the Administrator pursuant to § 592.6(d).

(4) With respect to any vehicle imported pursuant to § 591.5(f)(2)(ii) of this chapter that the Registered Importer has agreed to bring into compliance with all applicable standards and for which it has not certified and furnished a certificate of conformity to the Administrator, the Registered Importer must immediately notify the owner of the vehicle in writing that its registration has been suspended or revoked.

(e) *Continuing obligations.* A Registered Importer whose registration is suspended or revoked remains obligated under § 592.6(i) to notify owners and to remedy noncompliances or safety related defects for each vehicle for which it has furnished a certificate of conformity to the Administrator.

[69 FR 52098, Aug. 24, 2004]

§ 592.8 Inspection; release of vehicle and bond.

(a) With respect to any motor vehicle for which it must provide a certificate of conformity to the Administrator as required by § 592.6(d), a Registered Importer shall not obtain title, licensing, or registration of the motor vehicle for use on the public roads, or release custody of it for such titling, licensing, or registration, except in accordance with the provisions of this section.

(b) When conformance modifications to a motor vehicle have been completed, a Registered Importer shall submit the certification required by § 592.6(d) to the Administrator. In certifying a vehicle that the Administrator has determined to be substantially similar to one that has been certified by its original manufacturer for sale in the United States, the Registered Importer may rely on any certification by the original manufacturer with respect to identical safety features if it also certifies that any modification that it undertook did not affect the compliance of such safety features. Each submission shall be mailed by certified

§ 592.9

mail, return receipt requested, or by private carriers such as Federal Express, to: Administrator, National Highway Traffic Safety Administration, Room 6115, 400 7th Street SW., Washington, DC, 20590, Attn: NEF-32, or be submitted electronically by FAX (202-366-1024), or in person. Each submission shall identify the location where the vehicle will be stored and is available for inspection, pending NHTSA action upon the submission.

(c) Before the end of the 30th calendar day after receiving a complete certification under § 592.6(d), the Administrator may notify the Registered Importer in writing that an inspection of the vehicle is required to verify the certification. Written notice includes a proposed inspection date, which is as soon as practicable. If inspection of the vehicle indicates that the vehicle has been properly certified, at the conclusion of the inspection the Registered Importer is provided an instrument of release. If inspection of the vehicle shows that the vehicle has not been properly certified, the Registered Importer shall either make the modifications necessary to substantiate its certification, and provide a new certification for the standard(s) in the manner provided for in paragraph (b) of this section, or deliver the vehicle to the Secretary of the Treasury for export, or abandon it to the United States. Before the end of the 30th calendar day after receipt of new certification, the Administrator may require a further inspection in accordance with the provisions of this subsection.

(d) The Administrator may by written notice request the Registered Importer to verify its certification of a motor vehicle before the end of the 30th calendar day after the date the Administrator receives a complete certification under § 592.6(d). If the basis for such request is that the certification is false or contains a misrepresentation, the Registered Importer shall be afforded an opportunity to present written data, views, and arguments as to why the certification is not false or misleading or does not contain a misrepresentation. The Administrator may require an inspection pursuant to paragraph (c) of this section. The motor vehicle and performance

49 CFR Ch. V (10-1-10 Edition)

bond involved shall not be released unless the Administrator is satisfied with the certification.

(e) If the Registered Importer has received no written notice from the Administrator by the end of the 30th calendar day after it has furnished a complete certification under section 592.6(d) of this chapter, the Registered Importer may release the vehicle from custody, sell or offer it for sale, or have it titled, licensed, or registered for use on the public roads.

(f) If the Administrator accepts a certification without requiring an inspection, (s)he notifies the Registered Importer in writing, and provides a copy to the importer of record. Such notification shall be provided not later than the 25th calendar day after the Administrator has received such certification.

(g) Release of the performance bond shall constitute acceptance of certification or completion of inspection of the vehicle concerned, but shall not preclude a subsequent decision by the Administrator pursuant to 49 U.S.C. 30118 that the vehicle fails to conform to any applicable Federal motor vehicle safety standard.

[54 FR 40090, Sept. 29, 1989, as amended at 55 FR 37330, Sept. 11, 1990; 59 FR 52098, Oct. 14, 1994; 69 FR 52100, Aug. 24, 2004]

§ 592.9 Forfeiture of bond.

A Registered Importer is required by § 591.6 of this chapter to furnish a bond with respect to each motor vehicle that it imports. The conditions of the bond are set forth in § 591.8 of this chapter. Failure to fulfill any one of these conditions may result in forfeiture of the bond. A bond may be forfeited if the Registered Importer:

(a) Fails to bring the motor vehicle covered by the bond into compliance with all applicable standards issued under part 571 and part 581 of this chapter within 120 days from the date of entry;

(b) Fails to file with the Administrator a certificate that the motor vehicle complies with each Federal motor vehicle safety, bumper, and theft prevention standard in effect at the time the vehicle was manufactured and which applies to the vehicle;

(c) Fails to cause a motor vehicle to be available for inspection if it has received written notice from the Administrator that an inspection is required;

(d) Releases the motor vehicle before the Administrator accepts the certification and any modification thereof, if it has received written notice from the Administrator that there is reason to believe that the certification is false or contains a misrepresentation;

(e) Before the bond is released, releases custody of the motor vehicle to any person for license or registration for use on public roads, streets, and highways, or licenses or registers the vehicle, including titling the vehicle in the name of another person, unless 30 calendar days have elapsed after the Registered Importer has filed a complete certification under § 592.6(d), and the Registered Importer has not received written notice pursuant to paragraph (a)(3) or (a)(4) of this section. For purposes of this part, a vehicle is deemed to be released from custody if it is not located at a duly identified facility of the Registered Importer and the Registered Importer has not notified the Administrator in writing of the vehicle's location or, if written notice has been provided, if the Administrator is unable to inspect the vehicle, or if the Registered Importer has transferred title to any other person regardless of the vehicle's location; or

(f) Fails to deliver the vehicle, or cause it to be delivered, to the custody of the Bureau of Customs and Border Protection at any port of entry, for export or abandonment to the United States, and to execute all documents necessary to accomplish such purposes, if the Administrator has furnished it written notice that the vehicle has been found not to comply with all applicable Federal motor vehicle safety standards along with a demand that the vehicle be delivered for export or abandoned to the United States.

[69 FR 52100, Aug. 24, 2004]

PART 593—DETERMINATIONS THAT A VEHICLE NOT ORIGINALLY MANUFACTURED TO CONFORM TO THE FEDERAL MOTOR VEHICLE SAFETY STANDARDS IS ELIGIBLE FOR IMPORTATION

- Sec.
- 593.1 Scope.
- 593.2 Purpose.
- 593.3 Applicability.
- 593.4 Definitions.
- 593.5 Petitions for eligibility determinations.
- 593.6 Basis for petition.
- 593.7 Processing of petitions.
- 593.8 Determinations on the agency's initiative.
- 593.9 Effect of affirmative determinations; lists.
- 593.10 Availability for public inspection.

APPENDIX A TO PART 593—LIST OF VEHICLES DETERMINED TO BE ELIGIBLE FOR IMPORTATION

AUTHORITY: 49 U.S.C. 322 and 30141(b); delegation of authority at 49 CFR 1.50.

SOURCE: 54 FR 40099, Sept. 29, 1989, unless otherwise noted.

§ 593.1 Scope.

This part establishes procedures under section 108(c) of the National Traffic and Motor Vehicle Safety Act, as amended (15 U.S.C. 1397(c)), for making determinations whether a vehicle that was not originally manufactured to conform with all applicable Federal motor vehicle safety standards, and is not otherwise eligible for importation under part 591 of this chapter, may be imported into the United States because it can be modified to meet the Federal standards.

§ 593.2 Purpose.

The purpose of this part is to provide content and format requirements for any Registered Importer and manufacturer who wishes to petition the Administrator for a determination that a vehicle not originally manufactured to conform to all applicable Federal motor vehicle safety standards is eligible to be imported into the United States because it can be modified to meet the standards. The purpose of this part is also to specify procedures under which the Administrator makes eligibility determinations pursuant to

§ 593.3

those petitions as well as eligibility determinations on the agency's initiative.

§ 593.3 Applicability.

This part applies to a motor vehicle that was not originally manufactured and certified by its original manufacturer to conform with all applicable Federal motor vehicle safety standards and that is offered for importation into the United States.

§ 593.4 Definitions.

All terms in this part that are defined in section 102 of the National Traffic and Motor Vehicle Safety Act (15 U.S.C. 1391) are used as defined therein.

Administrator means the Administrator of the National Highway Traffic Safety Administration.

Model year means the year used by a manufacturer to designate a discrete vehicle model irrespective of the calendar year in which the vehicle was actually produced, or the model year as designated by the vehicle's country of origin, or, if neither the manufacturer nor the country of origin has made such a designation, the calendar year that begins on September 1 and ends on August 31 of the next calendar year.

NHTSA means the National Highway Traffic Safety Administration.

Registered Importer means any person who has been granted registered importer status by the Administrator pursuant to paragraph 592.5(b) of this chapter, and whose registration has not been revoked.

§ 593.5 Petitions for eligibility determinations.

(a) A manufacturer or Registered Importer may petition the Administrator for a determination that a vehicle that does not comply with all applicable Federal motor vehicle safety standards is eligible for importation, either

(1) On the basis that the vehicle:

(i) Is substantially similar to a vehicle which was originally manufactured for importation into and sale in the United States and which bore a certification affixed by its manufacturer pursuant to part 567 of this chapter, and

49 CFR Ch. V (10-1-10 Edition)

(ii) Is capable of being readily modified to conform to all applicable Federal motor vehicle safety standards; or

(2) On the basis that the vehicle has safety features that comply with or are capable of being modified to comply with all applicable Federal motor vehicle safety standards.

(b) Each petition filed under this part must—

(1) Be written in the English language;

(2) Be headed with the words "Petition for Import Eligibility Determination" and submitted in three copies to: Administrator, National Highway Traffic Safety Administration, Room 6115, 400 7th Street SW., Washington, DC 20590, Attn: NEF-32 Import Eligibility Determinations;

(3) State the full name and address of the petitioner.

(4) If the petitioner is a Registered Importer, include the Registered Importer Number assigned by NHTSA pursuant to part 592 of this chapter.

(5) Set forth the basis for the petition and the information required by § 593.6 (a) or (b), as appropriate;

(6) Specify any part of the information and data submitted which petitioner requests be withheld from public disclosure in accordance with part 512 of this chapter; and

(7) Submit a certified check payable to the Treasurer of the United States, for the amount of the vehicle eligibility petition fee established pursuant to part 594 of this chapter.

(c) The knowing and willful submission of false, fictitious or fraudulent information may subject the petitioner to the criminal penalties of 18 U.S.C. 1001.

[54 FR 40099, Sept. 29, 1989, as amended at 55 FR 37330, Sept. 11, 1990]

§ 593.6 Basis for petition.

(a) If the basis for the petition is that the vehicle is substantially similar to a vehicle which was originally manufactured for importation into and sale in the United States, and which was certified by its manufacturer pursuant to part 567 of this chapter, and that it is capable of being readily modified to conform to all applicable Federal

motor vehicle safety standards, the petitioner shall provide the following information:

(1) Identification of the original manufacturer, model, and model year of the vehicle for which a determination is sought.

(2) Identification of the original manufacturer, model, and model year of the vehicle which the petitioner believes to be substantially similar to that for which a determination is sought.

(3) Substantiation that the manufacturer of the vehicle identified by the petitioner under paragraph (a)(2) of this section originally manufactured it for importation into and sale in the United States, and affixed a label to it certifying that it complied with all applicable Federal motor vehicle safety standards.

(4) Data, views and arguments demonstrating that the vehicle identified by the petitioner under paragraph (a)(1) of this section is substantially similar to the vehicle identified by the petitioner under paragraph (a)(2) of this section.

(5) With respect to each Federal motor vehicle safety standard that applied to the vehicle identified by the petitioner under paragraph (a)(2) of this section, data, views, and arguments demonstrating that the vehicle identified by the petitioner under paragraph (a)(1) of this section either was originally manufactured to conform to such standard, or is capable of being readily modified to conform to such standard.

(b) If the basis of the petition is that the vehicle's safety features comply with or are capable of being modified to comply with all applicable Federal motor vehicle safety standards, the petitioner shall provide the following information:

(1) Identification of the model and model year of the vehicle for which a determination is sought.

(2) With respect to each Federal motor vehicle safety standard that would have applied to such vehicle had it been originally manufactured for importation into and sale in the United States, data, views, and arguments demonstrating that the vehicle has safety features that comply with or are capable of being modified to conform

with such standard. The latter demonstration shall include a showing that after such modifications, the features will conform with such standard.

§ 593.7 Processing of petitions.

(a) NHTSA will review each petition for sufficiency under §§ 593.5 and 593.6. If the petition does not contain all the information required by this part, NHTSA notifies the petitioner, pointing out the areas of insufficiency, and stating that the petition will not receive further consideration until the required information is provided. If the additional information is not provided within the time specified by NHTSA in its notification, NHTSA may dismiss the petition as incomplete, and so notify the petitioner. When the petition is complete, its processing continues.

(b) NHTSA publishes in the FEDERAL REGISTER, affording opportunity for comment, a notice of each petition containing the information required by this part.

(c) No public hearing, argument, or other formal proceeding is held on a petition filed under this part.

(d) If the Administrator is unable to determine that the vehicle in a petition submitted under § 593.6(a) is one that is substantially similar, or (if it is substantially similar) is capable of being readily modified to meet the standards, (s)he notifies the petitioner, and offers the petitioner the opportunity to supplement the petition by providing the information required for a petition submitted under paragraph 593.6(b).

(e) If the Administrator determines that the petition does not clearly demonstrate that the vehicle model is eligible for importation, (s)he denies it and notifies the petitioner in writing. (S)he also publishes in the FEDERAL REGISTER a notice of denial and the reasons for it. A notice of denial also states that the Administrator will not consider a new petition covering the model that is the subject of the denial until at least 3 months from the date of the notice of denial. There is no administrative reconsideration available for petition denials.

(f) If the Administrator determines that the petition clearly demonstrates that the vehicle model is eligible for

§ 593.8

importation, (s)he grants it and notifies the petitioner. (S)he also publishes in the FEDERAL REGISTER a notice of grant and the reasons for it.

[54 FR 40099, Sept. 29, 1989, as amended at 55 FR 37330, Sept. 11, 1990]

§ 593.8 Determinations on the agency's initiative.

(a) The Administrator may make a determination of eligibility on his or her own initiative. The agency publishes in the FEDERAL REGISTER, affording opportunity for comment, a notice containing the information available to the agency (other than confidential information) relevant to the basis upon which eligibility may be determined.

(b) No public hearing, argument, or other formal proceeding is held upon a notice published under this section.

(c) The Administrator publishes a second notice in the FEDERAL REGISTER in which (s)he announces his or her determination whether the vehicle is eligible or ineligible for importation, and states the reasons for the determination. A notice of ineligibility also announces that no further determination for the same model of motor vehicle will be made for at least 3 months following the date of publication of the notice. There is no administrative reconsideration available for a decision of ineligibility.

§ 593.9 Effect of affirmative determinations; lists.

(a) A notice of grant is sufficient authority for the importation by persons other than the petitioner of any vehicle of the same model specified in the grant.

(b) The Administrator publishes annually in the FEDERAL REGISTER a list of determinations made under Sec. 593.7, and Sec. 593.8.

§ 593.10 Availability for public inspection.

(a) Except as specified in paragraph (b) of this section, information relevant to a determination under this part, including a petition and supporting data, and the grant or denial of the petition or the making of a determination on the Administrator's initiative, is available for public inspection in the Docket Section, Room 5109,

49 CFR Ch. V (10-1-10 Edition)

National Highway Traffic Safety Administration, 400 Seventh St., SW., Washington, DC 20590. Copies of available information may be obtained, as provided in part 7 of this chapter.

(b) Except for release of confidential information authorized under part 512 of this chapter, information made available for inspection under paragraph (a) of this section does not include information for which confidentiality has been requested and granted in accordance with part 512 of this chapter, and 5 U.S.C. 552(b). To the extent that a petition contains material relating to the methodology by which the petitioner intends to achieve conformance with a specific standard, the petitioner may request confidential treatment of such material on the grounds that it contains a trade secret or confidential information in accordance with part 512 of this chapter.

APPENDIX A TO PART 593—LIST OF VEHICLES DETERMINED TO BE ELIGIBLE FOR IMPORTATION

(a) Each vehicle on the following list is preceded by a vehicle eligibility number. The importer of a vehicle admissible under any eligibility decision must enter that number on the HS-7 Declaration Form accompanying entry to indicate that the vehicle is eligible for importation.

(1) "VSA" eligibility numbers are assigned to all vehicles that are decided to be eligible for importation on the initiative of the Administrator under § 593.8.

(2) "VSP" eligibility numbers are assigned to vehicles that are decided to be eligible under § 593.7(f), based on a petition from a manufacturer or registered importer submitted under § 593.5(a)(1), which establishes that a substantially similar U.S.-certified vehicle exists.

(3) "VCP" eligibility numbers are assigned to vehicles that are decided to be eligible under § 593.7(f), based on a petition from a manufacturer or registered importer submitted under § 593.5(a)(2), which establishes that the vehicle has safety features that comply with, or are capable of being altered to comply with, all applicable FMVSS.

(b) Vehicles for which eligibility decisions have been made are listed alphabetically, first by make and then by model.

(c) All hyphens used in the Model Year column mean "through" (for example, "1988-1990" means "1988 through 1990").

(d) The initials "MC" used in the Make column mean "Motorcycle."

(e) The initials "SWB" used in the Model Type column mean "Short Wheel Base."

(f) The initials "LWB" used in the Model Type column mean "Long Wheel Base."

(g) For vehicles with a European country of origin, the term "Model Year" ordinarily means calendar year in which the vehicle was produced.

(h) All vehicles are left-hand-drive (LHD) vehicles unless noted as RHD. The initials "RHD" used in the Model Type column mean "Right-Hand-Drive."

VEHICLES CERTIFIED BY THEIR ORIGINAL MANUFACTURER AS COMPLYING WITH ALL APPLICABLE CANADIAN MOTOR VEHICLE SAFETY STANDARDS

VSA-80	<ul style="list-style-type: none"> (a) All passenger cars less than 25 years old that were manufactured before September 1, 1989; (b) All passenger cars manufactured on or after September 1, 1989, and before September 1, 1996, that, as originally manufactured, are equipped with an automatic restraint system that complies with Federal Motor Vehicle Safety Standard (FMVSS) No. 208; (c) All passenger cars manufactured on or after September 1, 1996, and before September 1, 2002, that, as originally manufactured, are equipped with an automatic restraint system that complies with FMVSS No. 208, and that comply with FMVSS No. 214; (d) All passenger cars manufactured on or after September 1, 2002, and before September 1, 2007, that, as originally manufactured, are equipped with an automatic restraint system that complies with FMVSS No. 208, and that comply with FMVSS Nos. 201, 214, 225, and 401; (e) All passenger cars manufactured on or after September 1, 2007, and before September 1, 2008, that, as originally manufactured, comply with FMVSS Nos. 110, 118, 138, 201, 208, 213, 214, 225, and 401; (f) All passenger cars manufactured on or after September 1, 2008 and before September 1, 2011 that, as originally manufactured, comply with FMVSS Nos. 110, 118, 138, 201, 202a, 206, 208, 213, 214, 225, and 401; (g) All passenger cars manufactured on or after September 1, 2011 and before September 1, 2012 that, as originally manufactured, comply with FMVSS Nos. 110, 118, 126, 138, 201, 202a, 206, 208, 213, 214, 225, and 401.
VSA-81	<ul style="list-style-type: none"> (a) All multipurpose passenger vehicles, trucks, and buses with a GVWR of 4,536 kg (10,000 lb) or less that are less than 25 years old and that were manufactured before September 1, 1991; (b) All multipurpose passenger vehicles, trucks, and buses with a GVWR of 4,536 kg (10,000 lb) or less that were manufactured on and after September 1, 1991, and before September 1, 1993 and that, as originally manufactured, comply with FMVSS Nos. 202 and 208;
VSA-81	<ul style="list-style-type: none"> (c) All multipurpose passenger vehicles, trucks, and buses with a GVWR of 4,536 kg (10,000 lb) or less that were manufactured on or after September 1, 1993, and before September 1, 1998, and that, as originally manufactured, comply with FMVSS Nos. 202, 208, and 216; (d) All multipurpose passenger vehicles, trucks, and buses with a GVWR of 4,536 kg (10,000 lb) or less that were manufactured on or after September 1, 1998, and before September 1, 2002, and that, as originally manufactured, comply with FMVSS Nos. 202, 208, 214, and 216; (e) All multipurpose passenger vehicles, trucks, and buses with a GVWR of 4,536 kg (10,000 lb) or less that were manufactured on or after September 1, 2002, and before September 1, 2007, and that, as originally manufactured, comply with FMVSS Nos. 201, 202, 208, 214, and 216, and, insofar as it is applicable, with FMVSS No. 225; (f) All multipurpose passenger vehicles, trucks, and buses with a GVWR of 4,536 kg (10,000 lb) or less manufactured on or after September 1, 2007 and before September 1, 2008, that, as originally manufactured, comply with FMVSS Nos. 110, 118, 201, 202, 208, 213, 214, and 216, and insofar as they are applicable, with FMVSS Nos. 138 and 225;

VEHICLES CERTIFIED BY THEIR ORIGINAL MANUFACTURER AS COMPLYING WITH ALL APPLICABLE CANADIAN MOTOR VEHICLE SAFETY STANDARDS—Continued

	(g) All multipurpose passenger vehicles, trucks, and buses with a GVWR of 4,536 kg (10,000 lb) or less manufactured on or after September 1, 2008 and before September 1, 2011, that, as originally manufactured, comply with FMVSS Nos. 110, 118, 201, 202a, 206, 208, 213, 214, and 216, and insofar as they are applicable, with FMVSS Nos. 138 and 225;
	(h) All multipurpose passenger vehicles, trucks, and buses with a GVWR of 4,536 kg (10,000 lb) or less manufactured on or after September 1, 2011 and before September 1, 2012, that, as originally manufactured, comply with FMVSS Nos. 110, 118, 126, 201, 202a, 206, 208, 213, 214, and 216, and insofar as they are applicable, with FMVSS Nos. 138 and 225.
VSA–82	All multipurpose passenger vehicles, trucks, and buses with a GVWR greater than 4,536 kg (10,000 lb) that are less than 25 years old.
VSA–83	All trailers and motorcycles less than 25 years old.

VEHICLES MANUFACTURED FOR OTHER THAN THE CANADIAN MARKET

Make	Model type(s)	Body	Model year(s)	VSP	VSA	VCP
Acura	Legend		1988	51		
Acura	Legend		1988	51		
Acura	Legend		1989	77		
Acura	Legend		1990–1992	305		
AL–Spaw	EMA Mobile Stage Trailer		2009			42
Alfa Romeo	164		1989	196		
Alfa Romeo	164		1991	76		
Alfa Romeo	164		1994	156		
Alfa Romeo	Spider		1987	70		
Alfa Romeo	Spyder		1992	503		
Alpina	B12 5.0	Sedan	1988–1994			41
Aston Martin	Vanquish		2002–2004	430		
Audi	80		1988–1989	223		
Audi	100		1989	93		
Audi	100		1993	244		
Audi	100		1990–1992	317		
Audi	A4		1996–2000	352		
Audi	A4, RS4, S4	8D	2000–2001	400		
Audi	A6		1998–1999	332		
Audi	A8		2000	424		
Audi	A8		1997–2000	337		
Audi	A8 Avant Quattro		1996	238		
Audi	RS6 & RS6 Avant		2003	443		
Audi	S6		1996	428		
Audi	S8		2000	424		
Audi	TT		2000–2001	364		
Bentley	Arnage (manufactured 1/1/01–12/31/01)		2001	473		
Bentley	Azure (LHD & RHD)		1998	485		
Bimota (MC)	DB4		2000	397		
Bimota (MC)	SB8		1999–2000	397		
Bimota (MC)	SB6		1994–1999	523		
BMW	316		1986	25		
BMW	3 Series		1998	462		
BMW	3 Series		1999	379		
BMW	3 Series		2000	356		
BMW	3 Series		2001	379		
BMW	3 Series		1995–1997	248		
BMW	3 Series		2003–2004	487		
BMW	318i, 318iA		1986		23	
BMW	318i, 318iA		1987–1989		23	
BMW	320i		1990–1991	283		
BMW	325, 325i, 325iA, 325E		1986		30	
BMW	325e, 325eA		1986–1987		24	
BMW	325i		1991	96		
BMW	325i		1992–1996	197		
BMW	325i, 325iA		1987–1989		30	
BMW	325iS, 325iSA		1987–1989		31	
BMW	325iX		1990	205		
BMW	325iX, 325iXA		1988–1989		33	
BMW	5 Series		2000	345		

VEHICLES MANUFACTURED FOR OTHER THAN THE CANADIAN MARKET—Continued

Make	Model type(s)	Body	Model year(s)	VSP	VSA	VCP
BMW	5 Series		1990-1995	194		
BMW	5 Series		1995-1997	249		
BMW	5 Series		1998-1999	314		
BMW	5 Series		2000-2002	414		
BMW	5 Series		2003-2004	450		
BMW	518i		1986	4		
BMW	520iA		1989	9		
BMW	524tdA		1986		26	
BMW	525i		1989	5		
BMW	528e, 528eA		1986-1988		21	
BMW	535i, 535iA		1986-1989		25	
BMW	635CSi, 635CSiA		1986-1989		27	
BMW	7 Series		1992	232		
BMW	7 Series		1990-1991	299		
BMW	7 Series		1993-1994	299		
BMW	7 Series		1995-1999	313		
BMW	7 Series		1999-2001	366		
BMW	728i		1986	14		
BMW	730iA		1988	6		
BMW	735i, 735iA		1986-1989		28	
BMW	745i		1986		73	
BMW	8 Series		1991-1995	361		
BMW	850 Series		1997	396		
BMW	850i		1990	10		
BMW	All other passenger car models except those in the M1 and Z1 series..		1986-1989		78	
BMW	L7		1986-1987		29	
BMW	M3		1988-1989		35	
BMW	M3 (manufactured prior to 9/1/06)		2006	520		
BMW	M5		1988		34	
BMW	M6		1987-1988		32	
BMW	X5 (manufactured 1/1/03-12/31/04)		2003-2004	459		
BMW	Z3		1996-1998	260		
BMW	Z3 (European market)		1999	483		
BMW	Z8		2002	406		
BMW	Z8		2000-2001	350		
BMW (MC)	C1		2000-2003			40
BMW (MC)	K1		1990-1993	228		
BMW (MC)	K100		1986-1992	285		
BMW (MC)	K1100, K1200		1993-1998	303		
BMW (MC)	K75		1996			36
BMW (MC)	K75S		1987-1995	229		
BMW (MC)	R1100		1994-1997	231		
BMW (MC)	R1100		1998-2001	368		
BMW (MC)	R1100RS		1994	177		
BMW (MC)	R1150GS		2000	453		
BMW (MC)	R1200C		1998-2001	359		
BMW (MC)	R80, R100		1986-1995	295		
Buell (MC)	All Models		1995-2002	399		
Cadillac	DeVille		1994-1999	300		
Cadillac	DeVille (manufactured 8/1/99-12/31/00)		2000	448		
Cadillac	Seville		1991	375		
Cagiva (MC)	Gran Canyon 900		1999	444		
Carrocerias	Cimarron trailer		2006-2007			37
Chevrolet	400SS		1995	150		
Chevrolet	Astro Van		1997	298		
Chevrolet	Blazer		1986	405		
Chevrolet	Blazer (plant code of "K" or "2" in the 11th position of the VIN).		1997	349		
Chevrolet	Blazer (plant code of "K" or "2" in the 11th position of the VIN).		2001	461		
Chevrolet	Camaro		1999	435		
Chevrolet	Cavalier		1997	369		
Chevrolet	Corvette		1992	365		
Chevrolet	Corvette	Coupe	1999	419		
Chevrolet	Suburban		1989-1991	242		
Chevrolet	Tahoe		2000	504		
Chevrolet	Tahoe		2001	501		
Chevrolet	Trailblazer (manufactured prior to 9/1/07) originally sold in the Kuwait market.		2007	514		
Chrysler	Daytona		1992	344		

VEHICLES MANUFACTURED FOR OTHER THAN THE CANADIAN MARKET—Continued

Make	Model type(s)	Body	Model year(s)	VSP	VSA	VCP
Chrysler	Grand Voyager		1998	373		
Chrysler	LHS (Mexican market)		1996	276		
Chrysler	Shadow (Middle Eastern market)		1989	216		
Chrysler	Town and Country		1993	273		
Citroen	XM		1990–1992			1
Dodge	Ram		1994–1995	135		
Ducati (MC)	748		1999–2003	421		
Ducati (MC)	851		1988	498		
Ducati (MC)	888		1993	500		
Ducati (MC)	900		2001	452		
Ducati (MC)	916		1999–2003	421		
Ducati (MC)	600SS		1992–1996	241		
Ducati (MC)	748 Biposto		1996–1997	220		
Ducati (MC)	900SS		1991–1996	201		
Ducati (MC)	996 Biposto		1999–2001	475		
Ducati (MC)	996R		2001–2002	398		
Ducati (MC)	MH900E		2001–2002	524		
Ducati (MC)	Monster 600		2001	407		
Ducati (MC)	ST4S		1999–2005	474		
Eagle	Vision		1994	323		
Ferrari	360		2001	376		
Ferrari	456		1995	256		
Ferrari	550		2001	377		
Ferrari	575		2002–2003	415		
Ferrari	575		2004–2005	507		
Ferrari	208, 208 Turbo	all models	1986–1988		76	
Ferrari	328	all models	1988–1989		37	
Ferrari	328 GTS		1986–1987		37	
Ferrari	348 TB		1992	86		
Ferrari	348 TS		1992	161		
Ferrari	360 (manufactured after 9/31/02)		2002	433		
Ferrari	360 (manufactured before 9/1/02)		2002	402		
Ferrari	360 Modena		1999–2000	327		
Ferrari	360 Series		2004	446		
Ferrari	360	Spider & Coupe	2003	410		
Ferrari	456 GT & GTA		1999	445		
Ferrari	456 GT & GTA		1997–1998	408		
Ferrari	512 TR		1993	173		
Ferrari	550 Marinello		1997–1999	292		
Ferrari	599 (manufactured prior to 9/1/06)		2006	518		
Ferrari	Enzo		2003–2004	436		
Ferrari	F355		1995	259		
Ferrari	F355		1999	391		
Ferrari	F355		1996–1998	355		
Ferrari	F430 (manufactured prior to 9/1/06)		2005–2006	479		
Ferrari	F50		1995	226		
Ferrari	Mondial (all models)		1986–1989		74	
Ferrari	Testarossa		1989		39	
Ferrari	Testarossa		1987–1988		39	
Ford	Bronco (manufactured in Venezuela)		1995–1996	265		
Ford	Escort (Nicaraguan market)		1996	322		
Ford	Escort RS Cosworth		1994–1995			9
Ford	Explorer (manufactured in Venezuela)		1991–1998	268		
Ford	F150		2000	425		
Ford	Mustang		1993	367		
Ford	Mustang		1997	471		
Ford	Windstar		1995–1998	250		
Freightliner	FLD12064ST		1991–1996	179		
Freightliner	FTLD112064SD		1991–1996	178		
GMC	Suburban		1992–1994	134		
Harley Davidson (MC)	FX, FL, XL Series		1998	253		
Harley Davidson (MC)	FX, FL, XL Series		1999	281		
Harley Davidson (MC)	FX, FL, XL Series		2000	321		
Harley Davidson (MC)	FX, FL, XL Series		2001	362		
Harley Davidson (MC)	FX, FL, XL Series		2002	372		
Harley Davidson (MC)	FX, FL, XL Series		2003	393		

VEHICLES MANUFACTURED FOR OTHER THAN THE CANADIAN MARKET—Continued

Make	Model type(s)	Body	Model year(s)	VSP	VSA	VCP
Harley Davidson (MC).	FX, FL, XL Series	2004	422	
Harley Davidson (MC).	FX, FL, XL Series	2005	472	
Harley Davidson (MC).	FX, FL, XL Series	2006	491	
Harley Davidson (MC).	FX, FL, XL Series	1986–1997	202	
Harley Davidson (MC).	FX, FL, XL & VR Series	2007	506	
Harley Davidson (MC).	FXSTC Soft Tail Custom	2007	499	
Harley Davidson (MC).	FX, FL, XL & VR Series	2008	517	
Harley Davidson (MC).	FX, FL, XL & VR Series	2009	522	
Harley Davidson (MC).	VRSCA	2002	374	
Harley Davidson (MC).	VRSCA	2003	394	
Harley Davidson (MC).	VRSCA	2004	422	
Hatty	45 ft double axle trailer	1999–2000	38
Heku	750 KG boat trailer	2005	33
Hobby	Exclusive 650 KMFE Trailer	2002–2003	29
Honda	Accord	1991	280	
Honda	Accord	1992–1999	319	
Honda	Accord (RHD)	Sedan & Wagon	1994–1997	451	
Honda	Civic DX	Hatchback	1989	128	
Honda	CRV	2002	447	
Honda	CR-V	2005	489	
Honda	Prelude	1989	191	
Honda	Prelude	1994–1997	309	
Honda (MC)	CB 750 (CB750F2T)	1996	440	
Honda (MC)	CB1000F	1988	106	
Honda (MC)	CBR250	1989–1994	22
Honda (MC)	CMX250C	1986–1987	348	
Honda (MC)	CP450SC	1986	174	
Honda (MC)	RVF 400	1994–2000	358	
Honda (MC)	VF750	1994–1998	290	
Honda (MC)	VFR 400	1994–2000	358	
Honda (MC)	VFR 400, RVF 400	1989–1993	24
Honda (MC)	VFR750	1990	34	
Honda (MC)	VFR750	1991–1997	315	
Honda (MC)	VFR800	1998–1999	315	
Honda (MC)	VT600	1991–1998	294	
Hyundai	Elantra	1992–1995	269	
Hyundai	XG350	2004	494	
Jaguar	Sovereign	1993	78	
Jaguar	S-Type	2000–2002	411	
Jaguar	XJ6	1987	47	
Jaguar	XJ6	1986	41	
Jaguar	XJ6 Sovereign	1988	215	
Jaguar	XJS	1991	175	
Jaguar	XJS	1992	129	
Jaguar	XJS	1986–1987	40	
Jaguar	XJS	1994–1996	195	
Jaguar	XJS, XJ6	1988–1990	336	
Jaguar	XK-8	1998	330	
Jeep	Cherokee	1993	254	
Jeep	Cherokee (European market)	1991	211	
Jeep	Cherokee (LHD & RHD)	1994	493	
Jeep	Cherokee (LHD & RHD)	1995	180	
Jeep	Cherokee (LHD & RHD)	1996	493	
Jeep	Cherokee (LHD & RHD)	1997–1998	516	
Jeep	Cherokee (LHD & RHD)	1997–2001	515	
Jeep	Cherokee (Venezuelan market)	1992	164	
Jeep	Grand Cherokee	1994	404	
Jeep	Grand Cherokee	1997	431	
Jeep	Grand Cherokee	2001	382	
Jeep	Grand Cherokee (LHD—Japanese market)	1997	389	

VEHICLES MANUFACTURED FOR OTHER THAN THE CANADIAN MARKET—Continued

Make	Model type(s)	Body	Model year(s)	VSP	VSA	VCP
Jeep	Liberty		2002	466		
Jeep	Liberty		2005	505		
Jeep	Liberty (Mexican market)		2004	457		
Jeep	Wrangler		1993	217		
Jeep	Wrangler		1995	255		
Jeep	Wrangler		1998	341		
Kawasaki (MC)	EL250		1992–1994	233		
Kawasaki (MC)	VN1500–P1/P2 series		2003	492		
Kawasaki (MC)	ZX1000–B1		1988	182		
Kawasaki (MC)	ZX400		1987–1997	222		
Kawasaki (MC)	ZX6, ZX7, ZX9, ZX10, ZX11		1987–1999	312		
Kawasaki (MC)	ZX600		1986–1998	288		
Kawasaki (MC)	ZZR1100		1993–1998	247		
Ken-Mex	T800		1990–1996	187		
Kenworth	T800		1992	115		
Komet	Standard, Classic & Eurolite trailer		2000–2005	477		
KTM (MC)	Duke II		1995–2000	363		
Lamborghini	Diablo (except 1997 Coupe)		1996–1997	416		
Lamborghini	Diablo	Coupe	1997			26
Lamborghini	Gallardo (manufactured 1/1/04–12/31/04)		2004	458		
Lamborghini	Gallardo (manufactured 1/1/06–8/31/06)		2006	508		
Lamborghini	Murcielago	Roadster	2005	476		
Land Rover	Defender 110		1993	212		
Land Rover	Defender 90	VIN & Body Limited	1994–1995	512		
Land Rover	Defender 90 (manufactured before 9/1/97) and VIN "SALDV224*VA" or "SALDV324*VA"		1997	432		
Land Rover	Discovery		1994–1998	338		
Land Rover	Discovery (II)		2000	437		
Land Rover	Range Rover		2004	509		
Lexus	GS300		1998	460		
Lexus	GS300		1993–1996	293		
Lexus	RX300		1998–1999	307		
Lexus	SC300		1991–1996	225		
Lexus	SC400		1991–1996	225		
Lincoln	Mark VII		1992	144		
Magni (MC)	Australia, Sfida		1996–1999	264		
Mazda	MPV		2000	413		
Mazda	MX–5 Miata		1990–1993	184		
Mazda	RX–7		1986	199		
Mazda	RX–7		1987–1995	279		
Mazda	Xedos 9		1995–2000	351		
Mercedes Benz	190 D	201.126	1986–1989		54	
Mercedes Benz	190 D (2.2)	201.122	1986–1989		54	
Mercedes Benz	190 E	201.029	1986		54	
Mercedes Benz	190 E	201.028	1990	22		
Mercedes Benz	190 E	201.036	1990	104		
Mercedes Benz	190 E	201.024	1991	45		
Mercedes Benz	190 E	201.028	1992	71		
Mercedes Benz	190 E	201.018	1992	126		
Mercedes Benz	190 E		1993	454		
Mercedes Benz	190 E	201.028	1986–1989		54	
Mercedes Benz	190 E (2.3)	201.024	1986–1989		54	
Mercedes Benz	190 E (2.6)	201.029	1987–1989		54	
Mercedes Benz	190 E (2.6) 16	201.034	1986–1989		54	
Mercedes Benz	200 D	124.120	1986	17		
Mercedes Benz	200 E	124.021	1989	11		
Mercedes Benz	200 E	124.012	1991	109		
Mercedes Benz	200 E	124.019	1993	75		
Mercedes Benz	200 TE	124.081	1989	3		
Mercedes Benz	220 E		1993	168		
Mercedes Benz	220 TE	Station Wagon	1993–1996	167		
Mercedes Benz	230 CE	124.043	1991	84		
Mercedes Benz	230 CE	123.043	1992	203		
Mercedes Benz	230 E	124.023	1988	1		
Mercedes Benz	230 E	124.023	1989	20		
Mercedes Benz	230 E	124.023	1990	19		
Mercedes Benz	230 E	124.023	1991	74		
Mercedes Benz	230 E	124.023	1993	127		
Mercedes Benz	230 E	124.023	1986–1987		55	
Mercedes Benz	230 TE	124.083	1989	2		

VEHICLES MANUFACTURED FOR OTHER THAN THE CANADIAN MARKET—Continued

Make	Model type(s)	Body	Model year(s)	VSP	VSA	VCP
Mercedes Benz	250 D		1992	172		
Mercedes Benz	250 E		1990-1993	245		
Mercedes Benz	260 E	124.026	1986		55	
Mercedes Benz	260 E	124.026	1992	105		
Mercedes Benz	260 E	124.026	1987-1989		55	
Mercedes Benz	260 SE	126.020	1986	18		
Mercedes Benz	260 SE	126.020	1989	28		
Mercedes Benz	280 E		1993	166		
Mercedes Benz	280 SE	116.024	1986-1988		51	
Mercedes Benz	300 CE	124.051	1990	64		
Mercedes Benz	300 CE	124.051	1991	83		
Mercedes Benz	300 CE	124.050	1992	117		
Mercedes Benz	300 CE	124.061	1993	94		
Mercedes Benz	300 CE	124.050	1988-1989		55	
Mercedes Benz	300 D	124.130	1986		55	
Mercedes Benz	300 D Turbo	124.193	1986		55	
Mercedes Benz	300 D Turbo	124.193	1987-1989		55	
Mercedes Benz	300 DT	124.133	1986-1989		55	
Mercedes Benz	300 E	124.031	1992	114		
Mercedes Benz	300 E	124.030	1986-1989		55	
Mercedes Benz	300 E 4-Matic		1990-1993	192		
Mercedes Benz	300 SD	126.120	1986-1989		53	
Mercedes Benz	300 SE	126.024	1990	68		
Mercedes Benz	300 SE	126.024	1986-1987		53	
Mercedes Benz	300 SE	126.024	1988-1989		53	
Mercedes Benz	300 SEL	126.025	1986		53	
Mercedes Benz	300 SEL	126.025	1987		53	
Mercedes Benz	300 SEL	126.025	1990	21		
Mercedes Benz	300 SEL	126.025	1988-1989		53	
Mercedes Benz	300 SL	107.041	1989	7		
Mercedes Benz	300 SL	129.006	1992	54		
Mercedes Benz	300 SL	107.041	1986-1988		44	
Mercedes Benz	300 TE	124.090	1990	40		
Mercedes Benz	300 TE		1992	193		
Mercedes Benz	300 TE	124.090	1986-1989		55	
Mercedes Benz	320 CE		1993	310		
Mercedes Benz	320 SL		1992-1993	142		
Mercedes Benz	380 SE	126.043	1986-1989		53	
Mercedes Benz	380 SE	126.032	1986-1989		53	
Mercedes Benz	380 SEL	126.033	1986-1989		53	
Mercedes Benz	380 SL	107.045	1986-1989		44	
Mercedes Benz	380 SLC	107.025	1986-1989		44	
Mercedes Benz	400 SE		1992-1994	296		
Mercedes Benz	420 E		1993	169		
Mercedes Benz	420 SE	126.034	1986		53	
Mercedes Benz	420 SE	126.034	1987-1989		53	
Mercedes Benz	420 SE		1990-1991	230		
Mercedes Benz	420 SEC		1990	209		
Mercedes Benz	420 SEL	126.035	1990	48		
Mercedes Benz	420 SEL	126.035	1986-1989		53	
Mercedes Benz	420 SL	107.047	1986		44	
Mercedes Benz	450 SEL	116.033	1986-1988		51	
Mercedes Benz	450 SEL (6.9)	116.036	1986-1988		51	
Mercedes Benz	450 SL	107.044	1986-1989		44	
Mercedes Benz	450 SLC	107.024	1986-1989		44	
Mercedes Benz	500 E	124.036	1991	56		
Mercedes Benz	500 SE	126.036	1988	35		
Mercedes Benz	500 SE		1990	154		
Mercedes Benz	500 SE	140.050	1991	26		
Mercedes Benz	500 SE	126.036	1986		53	
Mercedes Benz	500 SEC	126.044	1990	66		
Mercedes Benz	500 SEC	126.044	1986-1989		53	
Mercedes Benz	500 SEL		1990	153		
Mercedes Benz	500 SEL	126.037	1991	63		
Mercedes Benz	500 SEL	126.037	1986-1989		53	
Mercedes Benz	500 SL	129.066	1989	23		
Mercedes Benz	500 SL	126.066	1991	33		
Mercedes Benz	500 SL	129.006	1992	60		
Mercedes Benz	500 SL	107.046	1986-1989		44	
Mercedes Benz	560 SEC	126.045	1990	141		
Mercedes Benz	560 SEC		1991	333		
Mercedes Benz	560 SEC	126.045	1986-1989		53	

VEHICLES MANUFACTURED FOR OTHER THAN THE CANADIAN MARKET—Continued

Make	Model type(s)	Body	Model year(s)	VSP	VSA	VCP
Mercedes Benz	560 SEL	126.039	1990	89		
Mercedes Benz	560 SEL	140	1991	469		
Mercedes Benz	560 SEL	126.039	1986–1989		53	
Mercedes Benz	560 SL	107.048	1986–1989		44	
Mercedes Benz	600 SEC	Coupe	1993	185		
Mercedes Benz	600 SEL	140.057	1993–1998	271		
Mercedes Benz	600 SL	129.076	1992	121		
Mercedes Benz	All other passenger car models except Model ID 114 and 115 with sales designations "long," "station wagon," or "ambulance".		1986–1989		77	
Mercedes Benz	C 320	203	2001–2002	441		
Mercedes Benz	C Class		1994–1999	331		
Mercedes Benz	C Class	203	2000–2001	456		
Mercedes Benz	C Class	221	2003–2006	521		
Mercedes Benz	CL 500		1998	277		
Mercedes Benz	CL 500		1999–2001	370		
Mercedes Benz	CL 600		1999–2001	370		
Mercedes Benz	CLK 320		1998	357		
Mercedes Benz	CLK Class		1999–2001	380		
Mercedes Benz	CLK–Class	209	2002–2005	478		
Mercedes Benz	E 200		1994	207		
Mercedes Benz	E 200		1995–1998	278		
Mercedes Benz	E 220		1994–1996	168		
Mercedes Benz	E 250		1994–1995	245		
Mercedes Benz	E 280		1994–1996	166		
Mercedes Benz	E 320		1994–1998	240		
Mercedes Benz	E 320	211	2002–2003	418		
Mercedes Benz	E 320	Station Wagon	1994–1999	318		
Mercedes Benz	E 420		1994–1996	169		
Mercedes Benz	E 500		1994	163		
Mercedes Benz	E 500		1995–1997	304		
Mercedes Benz	E Class	W210	1996–2002	401		
Mercedes Benz	E Class	211	2003–2004	429		
Mercedes Benz	E Series		1991–1995	354		
Mercedes Benz	G-Wagon	463	1996			11
Mercedes Benz	G-Wagon	463	1997			15
Mercedes Benz	G-Wagon	463	1998			16
Mercedes Benz	G-Wagon	463	1999–2000			18
Mercedes Benz	G-Wagon 300	463.228	1993			3
Mercedes Benz	G-Wagon 300	463.228	1994			5
Mercedes Benz	G-Wagon 300	463.228	1990–1992			5
Mercedes Benz	G-Wagon 320 LWB	463	1995			6
Mercedes Benz	G-Wagon 5 DR LWB	463	2001			21
Mercedes Benz	G-Wagon 5 DR LWB	463	2002	392		
Mercedes Benz	G-Wagon 5 DR LWB		2006–2007	527		
Mercedes Benz	G-Wagon LWB V–8	463	1992–1996			13
Mercedes Benz	G-Wagon SWB	463	2005			31
Mercedes Benz	G-Wagon SWB	463	1990–1996			14
Mercedes Benz	G-Wagon SWB Cabriolet & 3DR	463	2004			28
Mercedes Benz	G-Wagon SWB Cabriolet & 3DR	463	2001–2003			25
Mercedes Benz	G-Wagon SWB Cabriolet & 3DR (manufactured before 9/1/06).	463	2006			35
Mercedes Benz	Maybach		2004	486		
Mercedes Benz	S 280	140.028	1994	85		
Mercedes Benz	S 320		1994–1998	236		
Mercedes Benz	S 420		1994–1997	267		
Mercedes Benz	S 500		1994–1997	235		
Mercedes Benz	S 500		2000–2001	371		
Mercedes Benz	S 600		1995–1999	297		
Mercedes Benz	S 600		2000–2001	371		
Mercedes Benz	S 600	Coupe	1994	185		
Mercedes Benz	S 600L		1994	214		
Mercedes Benz	S Class		1993	395		
Mercedes Benz	S Class	140	1991–1994	423		
Mercedes Benz	S Class		1995–1998	342		
Mercedes Benz	S Class		1998–1999	325		
Mercedes Benz	S Class	W220	1999–2002	387		
Mercedes Benz	S Class	220	2002–2004	442		
Mercedes Benz	S Class (manufactured before 9/1/06)		2005–2006	525		
Mercedes Benz	SE Class		1992–1994	343		
Mercedes Benz	SEL Class	140	1992–1994	343		

VEHICLES MANUFACTURED FOR OTHER THAN THE CANADIAN MARKET—Continued

Make	Model type(s)	Body	Model year(s)	VSP	VSA	VCP
Mercedes Benz	SL Class		1993-1996	329		
Mercedes Benz	SL Class	W129	1997-2000	386		
Mercedes Benz	SL Class	R230	2001-2002			19
Mercedes Benz	SL-Class (European market)	230	2003-2005	470		
Mercedes Benz	SLK		1997-1998	257		
Mercedes Benz	SLK		2000-2001	381		
Mercedes Benz	SLK Class (manufactured between 8/31/04 and 8/31/06).	171	2005-2006	511		
Mercedes Benz (truck).	Sprinter		2001-2005	468		
Mini	Cooper (European market)	Convertible	2005	482		
Mitsubishi	Galant Super Salon		1989	13		
Mitsubishi	Galant VX		1988	8		
Moto Guzzi (MC)	California		2000-2001	495		
Moto Guzzi (MC)	California EV		2002	403		
Moto Guzzi (MC)	Daytona		1993	118		
Moto Guzzi (MC)	Daytona RS		1996-1999	264		
MV Agusta (MC)	F4		2000	420		
Nissan	240SX		1988	162		
Nissan	GTS & GTR(RHD) a.k.a. "Skyline" manufactured 1/96-6/98.	R33	1996-1998			32
Nissan	Maxima		1989	138		
Nissan	Pathfinder		2002	412		
Nissan	Pathfinder		1987-1995	316		
Nissan	Stanza		1987	139		
Peugeot	405		1989	65		
Plymouth	Voyager		1996	353		
Pontiac	Firebird Trans Am		1995	481		
Pontiac (MPV)	Trans Sport		1993	189		
Porsche	911 Series		1991	526		
Porsche	911		1997-2000	346		
Porsche	928		1991-1996	266		
Porsche	928		1993-1998	272		
Porsche	911 Carrera	996	2002-2004	439		
Porsche	911 (996) GT3		2004	438		
Porsche	911 C4		1990	29		
Porsche	911 Cabriolet		1986-1989		56	
Porsche	911 Carrera		1993	165		
Porsche	911 Carrera		1994	103		
Porsche	911 Carrera		1986-1989		56	
Porsche	911 Carrera		1995-1996	165		
Porsche	911 Carrera 2 & Carrera 4		1992	52		
Porsche	911 Carrera Cabriolet (manufactured prior to 9/1/06).		2005-2006	513		
Porsche	911	Coupe	1986-1989		56	
Porsche	911 Targa		1986-1989		56	
Porsche	911 Turbo		1992	125		
Porsche	911 Turbo		2001	347		
Porsche	911 Turbo		1986-1989		56	
Porsche	924	Coupe	1986-1989		59	
Porsche	924 S		1987-1989		59	
Porsche	924 Turbo	Coupe	1986-1989		59	
Porsche	928	Coupe	1986-1989		60	
Porsche	928 GT		1986-1989		60	
Porsche	928 S	Coupe	1986-1989		60	
Porsche	928 S4		1990	210		
Porsche	928 S4		1986-1989		60	
Porsche	944	Coupe	1986-1989		61	
Porsche	944 S	Cabriolet	1990	97		
Porsche	944 S	Coupe	1987-1989		61	
Porsche	944 S2 (2-door Hatchback)		1990	152		
Porsche	944 Turbo	Coupe	1986-1989		61	
Porsche	946 Turbo		1994	116		
Porsche	All other passenger car models except Model 959.		1986-1989		79	
Porsche	Boxster		1997-2001	390		
Porsche	Boxster (manufactured before 9/1/02)		2002	390		
Porsche	Carrera GT		2004-2005	463		
Porsche	Cayenne		2003-2004	464		
Porsche	Cayenne (manufactured prior to 9/1/06)		2006	519		
Porsche	GT2		2001			20
Porsche	GT2		2002	388		

VEHICLES MANUFACTURED FOR OTHER THAN THE CANADIAN MARKET—Continued

Make	Model type(s)	Body	Model year(s)	VSP	VSA	VCP
Rolls Royce	Bentley		1987-1989	340		
Rolls Royce	Bentley Brooklands		1993	186		
Rolls Royce	Bentley Continental R		1990-1993	258		
Rolls Royce	Bentley Turbo		1986	53		
Rolls Royce	Bentley Turbo R		1995	243		
Rolls Royce	Bentley Turbo R		1992-1993	291		
Rolls Royce	Phantom		2004	455		
Saab	9.3		2003	426		
Saab	9000		1988	59		
Saab	9000		1994	334		
Saab	900 S		1987-1989	270		
Saab	900 SE		1995	213		
Saab	900 SE		1990-1994	219		
Saab	900 SE		1996-1997	219		
Smart Car	Fortwo (incl. trim levels passion, pulse, & pure).	Coupe & Cabriolet	2005			30
Smart Car	Fortwo (incl. trim levels passion, pulse, & pure).	Coupe & Cabriolet	2002-2004			27
Smart Car	Fortwo (incl. trim levels passion, pulse, & pure) manufactured before 9/1/06.	Coupe & Cabriolet	2006			34
Smart Car	Fortwo (incl. trim levels passion, pulse, & pure) manufactured before 9/1/06.	Coupe & Cabriolet	2007			39
Subaru	Forester		2006-2007	510		
Suzuki (MC)	GSF 750		1996-1998	287		
Suzuki (MC)	GSX1300R a.k.a. "Hayabusa"		1999-2006	484		
Suzuki (MC)	GSX-R 1100		1986-1997	227		
Suzuki (MC)	GSX-R 750		1986-1998	275		
Suzuki (MC)	GSX-R 750		1999-2003	417		
Toyota	4-Runner		1998	449		
Toyota	Avalon		1995-1998	308		
Toyota	Camry		1989	39		
Toyota	Camry		1987-1988		63	
Toyota	Celica		1987-1988		64	
Toyota	Corolla		1987-1988		65	
Toyota	Land Cruiser		1989	101		
Toyota	Land Cruiser		1986-1988	252		
Toyota	Land Cruiser		1990-1996	218		
Toyota	MR2		1990-1991	324		
Toyota	Previa		1991-1992	326		
Toyota	Previa		1993-1997	302		
Toyota	RAV4		1996	328		
Toyota	RAV4		2005	480		
Toyota	Van		1987-1988	200		
Triumph (MC)	Thunderbird		1995-1999	311		
Vespa (MC)	ET2, ET4		2001-2002	378		
Vespa (MC)	LX and PX		2004-2005	496		
Volkswagen	Eurovan		1993-1994	306		
Volkswagen	Golf		1987	159		
Volkswagen	Golf		1988	80		
Volkswagen	Golf		2005	502		
Volkswagen	Golf III		1993	92		
Volkswagen	Golf Rallye		1988	73		
Volkswagen	Golf Rallye		1989	467		
Volkswagen	GTI (Canadian market)		1991	149		
Volkswagen	Jetta		1994-1996	274		
Volkswagen	Passat	Wagon & Sedan	2004	488		
Volkswagen	Passat 4-door	Sedan	1992	148		
Volkswagen	Scirocco		1986	42		
Volkswagen	Transporter		1990	251		
Volkswagen	Transporter		1986-1987	490		
Volkswagen	Transporter		1988-1989	284		
Volvo	740 GL		1992	137		
Volvo	740	Sedan	1988	87		
Volvo	850 Turbo		1995-1998	286		
Volvo	940 GL		1992	137		
Volvo	940 GL		1993	95		
Volvo	945 GL	Wagon	1994	132		
Volvo	960	Sedan & Wagon	1994	176		
Volvo	C70		2000	434		
Volvo	S70		1998-2000	335		
Yamaha (MC)	Drag Star 1100		1999-2007	497		
Yamaha (MC)	FJ1200 (4 CR)		1991	113		

VEHICLES MANUFACTURED FOR OTHER THAN THE CANADIAN MARKET—Continued

Make	Model type(s)	Body	Model year(s)	VSP	VSA	VCP
Yamaha (MC)	FJR1300	2002	23
Yamaha (MC)	R1	2000	360
Yamaha (MC)	Virago	1990–1998	301

[75 FR 57398, Sept. 21, 2010]

**PART 594—SCHEDULE OF FEES
AUTHORIZED BY 49 U.S.C. 30141**

Sec.

- 594.1 Scope.
- 594.2 Purpose.
- 594.3 Applicability.
- 594.4 Definitions.
- 594.5 Establishment and payment of fees.
- 594.6 Annual fee for administration of the registration program.
- 594.7 Fee for filing petitions for a determination whether a vehicle is eligible for importation.
- 594.8 Fee for importing a vehicle pursuant to a determination by the Administrator.
- 594.9 Fee for reimbursement of bond processing costs and costs for processing offers of cash deposits or obligations of the United States in lieu of sureties on bonds.
- 594.10 Fee for review and processing of conformity certificate.

AUTHORITY: 49 U.S.C. 30141, 31 U.S.C. 9701; delegation of authority at 49 CFR 1.50.

SOURCE: 54 FR 40107, Sept. 29, 1989, unless otherwise noted.

§ 594.1 Scope.

This part establishes the fees authorized by 49 U.S.C. 30141.

[61 FR 51045, Sept. 30, 1996]

§ 594.2 Purpose.

The purposes of this part is to ensure that NHTSA is reimbursed for costs incurred in administering the importer registration program, in making determinations whether a nonconforming vehicle is eligible for importation into the United States, and in processing the bond furnished to the Secretary of the Treasury given to ensure that an imported vehicle not originally manufactured to conform to all applicable Federal motor vehicle safety standards is brought into compliance with the safety standards, or will be exported, or abandoned to the United States.

§ 594.3 Applicability.

This part applies to any person who applies to NHTSA to be granted the status of Registered Importer under part 592 of this chapter, to any person who has been granted such status, to any manufacturer not a Registered Importer who petitions the Administrator for a determination pursuant to part 593 of this chapter, and to any person who imports a motor vehicle into the United States pursuant to such determination.

[55 FR 40667, Oct. 4, 1990]

§ 594.4 Definitions.

All terms used in this part that are defined in 49 U.S.C. 30102 are used as defined in that section.

Administrator means the Administrator of the National Highway Traffic Safety Administration.

NHTSA means the National Highway Traffic Safety Administration.

Registered Importer means any person who has been granted the status of registered importer under part 592 of this chapter, and whose registration has not been revoked.

[54 FR 40107, Sept. 29, 1989, as amended at 61 FR 51045, Sept. 30, 1996]

§ 594.5 Establishment and payment of fees.

(a) The fees established by this part continue in effect until adjusted by the Administrator. The Administrator reviews the amount or rate of fees established under this part and, if appropriate, adjusts them by rule at least every 2 years.

(b) The fees applicable in any fiscal year are established before the beginning of such year. Each fee is calculated in accordance with this part, and is published in the FEDERAL REGISTER not later than September 30 of each year.

(c) An applicant for status as Registered Importer shall submit an initial

§ 594.6

49 CFR Ch. V (10–1–10 Edition)

annual fee with the application. A Registered Importer shall pay an annual fee not later than October 31 of each year. The fee is that specified in § 594.6(i).

(d) A person who petitions the Administrator for a determination that a vehicle is eligible for importation shall file with the petition the fee specified in § 594.7(e).

(e) No application or petition will be accepted for filing or processed before payment of the full amount specified. Except as provided in § 594.6(d), a fee shall be paid irrespective of NHTSA's disposition of the application, or of a withdrawal of an application.

(f) The Administrator will furnish each Registered Importer with a monthly invoice of the fees owed by the Registered Importer for reimbursement for bond processing costs and for the review and processing of conformity certificates and information regarding importation of motor vehicles as provided in Section 592.4 of this chapter. A person who for personal use imports a vehicle covered by a determination of the Administrator must pay the fee specified in either § 594.8(b) or (c), as appropriate, to the Registered Importer, and the invoice will also include these fees. The Registered Importer must pay the fees within 15 days of the date of the invoice.

(g) Fee payments must be by certified check, cashier's check, money order, credit card, or Electronic Funds Transfer System, made payable to the Treasurer of the United States.

[54 FR 40107, Sept. 29, 1989, as amended at 55 FR 40667, Oct. 4, 1990; 62 FR 50882, Sept. 29, 1997; 69 FR 52100, Aug. 24, 2004]

§ 594.6 Annual fee for administration of the registration program.

(a) Each person filing an application to be granted the status of a Registered Importer pursuant to part 592 of this chapter on or after October 1, 2010, must pay an annual fee of \$795, as calculated below, based upon the direct and indirect costs attributable to:

(1) Processing and acting upon such application;

(2) Any inspection deemed required for a determination upon such application;

(3) The estimated remaining activities of administering the registration program in the fiscal year in which such application is intended to become effective.

(b) That portion of the initial annual fee attributable to the processing of the application for applications filed on and after October 1, 2010, is \$320. The sum of \$320, representing this portion, shall not be refundable if the application is denied or withdrawn.

(c) If, in order to make a determination upon an application, NHTSA must make an inspection of the applicant's facilities, NHTSA notifies the applicant in writing after the conclusion of any such inspection, that a supplement to the initial annual fee in a stated amount is due upon receipt of such notice to recover the direct and indirect costs associated with such inspection and notification, and that no determination will be made upon the application until such sum is received. Such sum is not refundable if the application is denied or withdrawn.

(d) That portion of the initial annual fee attributable to the remaining activities of administering the registration program on and after October 1, 2010, is set forth in paragraph (i) of this section. This portion shall be refundable if the application is denied, or withdrawn before final action upon it.

(e) Each Registered Importer who wishes to maintain the status of Registered Importer shall pay a regular annual fee based upon the direct and indirect costs of administering the registration program, including the suspension and reinstatement, and revocation of such registration.

(f) The elements of administering the registration program that are included in the regular annual fee are:

(1) Calculating, revising, and publishing the fees to apply in the next fiscal year, including such coordination as may be required with the U.S. Customs Service.

(2) Processing and reviewing the annual statement attesting to the fact that no material change has occurred in the Registered Importer's status since filing its original application.

(3) Processing the annual fee.

(4) Processing and reviewing any amendments to an annual statement received in the course of a fiscal year.

(5) Verifying through inspection or otherwise that a Registered Importer is complying with the requirements of Sec. 592.6(b)(3) of this chapter for recordkeeping.

(6) Verifying through inspection or otherwise that a Registered Importer is able technically and financially to carry out its responsibilities pursuant to 49 U.S.C. 30118 *et seq.*

(7) Invoking procedures for suspension of registration and its reinstatement, and for revocation of registration pursuant to Sec. 592.7 of this chapter.

(g) The direct costs included in establishing the annual fee for maintaining registered importer status are the estimated costs of professional and clerical staff time, computer and computer operator time, and postage, per Registered Importer. The direct costs included in establishing the annual fee for a specific Registered Importer are costs of transportation and *per diem* attributable to inspections conducted with respect to that Registered Importer in administering the registration program, which have not been included in a previous annual fee.

(h) The indirect costs included in establishing the annual fee for maintaining Registered Importer status are a pro rata allocation of the average salary and benefits of persons employed in processing annual statements, or changes thereto, in recommending continuation of Registered Importer status, and a pro rata allocation of the costs attributable to maintaining the office space, and the computer or word processor. This cost is \$20.67 per man-hour for the period beginning October 1, 2010.

(i) Based upon the elements and indirect costs of paragraphs (f), (g), and (h) of this section, the component of the initial annual fee attributable to administration of the registration program, covering the period beginning October 1, 2010, is \$475. When added to the costs of registration of \$320, as set forth in paragraph (b) of this section, the costs per applicant to be recovered through the annual fee are \$795. The annual renewal registration fee for the

period beginning October 1, 2010, is \$670.

[54 FR 40107, Sept. 29, 1989; 55 FR 78, Jan. 2, 1990, as amended at 55 FR 40667, Oct. 4, 1990; 56 FR 49429, Sept. 30, 1991; 58 FR 51023, Sept. 30, 1993; 61 FR 51045, Sept. 30, 1996; 63 FR 45185, Aug. 25, 1998; 65 FR 56500, Sept. 19, 2000; 67 FR 60599, Sept. 26, 2002; 67 FR 62897, Oct. 9, 2002; 69 FR 57873, Sept. 28, 2004; 71 FR 43989, Aug. 3, 2006; 73 FR 54986, Sept. 24, 2008; 75 FR 48612, Aug. 11, 2010]

§ 594.7 Fee for filing petitions for a determination whether a vehicle is eligible for importation.

(a) Each manufacturer or registered importer who petitions NHTSA for a determination that—

(1) A nonconforming vehicle is substantially similar to a vehicle originally manufactured for importation into and sale in the United States and of the same model year as the model for which petition is made, and is capable of being readily modified to conform to all applicable Federal motor vehicle safety standards, or

(2) A nonconforming vehicle has safety features that comply with or are capable of being modified to comply with all applicable Federal motor vehicle safety standards,

shall pay a fee based upon the direct and indirect costs of processing and acting upon such petition.

(b) The direct costs attributable to processing a petition filed pursuant to paragraph (a) of this section include the average cost per professional staff-hour, computer and computer operator time, and postage. The direct costs also include those attributable to any inspection of a vehicle requested by a petitioner in substantiation of its petition.

(c) The indirect costs attributable to processing and acting upon a petition filed pursuant to paragraph (a) of this section include a pro rata allocation of the average salary and benefits of persons employed in processing the petitions and recommending decisions on them, and a pro rata allocation of the costs attributable to maintaining the office space, and the computer or word processor.

(d) The direct costs attributable to acting upon a petition filed pursuant to paragraph (a) of this section, also include the cost of publishing a notice in

§594.8

the FEDERAL REGISTER seeking public comment, the cost of publishing a second notice with the agency's determination, and a pro rata share of the cost of publishing an annual list of nonconforming vehicles determined to be eligible for importation.

(e) For petitions filed on and after October 1, 2010, the fee payable for seeking a determination under paragraph (a)(1) of this section is \$175. The fee payable for a petition seeking a determination under paragraph (a)(2) of this section is \$800. If the petitioner requests an inspection of a vehicle, the sum of \$827 shall be added to such fee. No portion of this fee is refundable if the petition is withdrawn or denied.

(f) In adopting a fee for the next fiscal year, the Administrator employs data based upon the cost of determinations and the amount of fees received for the 12-month period ending June 30 of the fiscal year preceding that fiscal year.

[54 FR 40107, Sept. 29, 1989, as amended at 55 FR 40667, Oct. 4, 1990; 56 FR 49429, Sept. 30, 1991; 58 FR 51023, Sept. 30, 1993; 61 FR 51045, Sept. 30, 1996; 65 FR 56500, Sept. 19, 2000; 67 FR 60599, Sept. 26, 2002; 69 FR 57873, Sept. 28, 2004; 71 FR 43990, Aug. 3, 2006; 73 FR 54986, Sept. 24, 2008; 75 FR 48613, Aug. 11, 2010]

§594.8 Fee for importing a vehicle pursuant to a determination by the Administrator.

(a) A fee as specified in paragraphs (b) and (c) of this section shall be paid by each importer of a vehicle covered by a determination made under part 593 of this chapter to cover the direct and indirect costs incurred by NHTSA in making such determinations.

(b) If a determination has been made pursuant to a petition, the fee for each vehicle is \$158. The direct and indirect costs that determine the fee are those set forth in §594.7(b), (c), and (d).

(c) If a determination has been made on or after October 1, 2010, pursuant to the Administrator's initiative, the fee for each vehicle is \$125. The direct and indirect costs that determine the fee are those set forth in §§594.7(b), (c), and (d), and references to "petition" shall be understood as relating to NHTSA's documents that serve as a basis for ini-

49 CFR Ch. V (10–1–10 Edition)

tiating determinations on its own initiative.

[55 FR 40667, Oct. 4, 1990, as amended at 58 FR 51023, Sept. 30, 1993; 61 FR 51045, Sept. 30, 1996; 63 FR 45186, Aug. 25, 1998; 65 FR 56500, Sept. 19, 2000; 67 FR 60599, Sept. 26, 2002; 69 FR 57874, Sept. 28, 2004; 71 FR 43990, Aug. 3, 2006; 73 FR 54986, Sept. 24, 2008; 75 FR 48613, Aug. 11, 2010]

§594.9 Fee for reimbursement of bond processing costs and costs for processing offers of cash deposits or obligations of the United States in lieu of sureties on bonds.

(a) Each Registered Importer must pay a fee based upon the direct and indirect costs of processing each bond furnished to the Secretary of Homeland Security on behalf of the Administrator with respect to each vehicle for which it furnishes a certificate of conformity pursuant to §592.6(d) of this chapter.

(b) The direct and indirect costs attributable to processing a bond are provided to NHTSA by the U.S. Customs Service.

(c) The bond processing fee for each vehicle imported on and after October 1, 2010, for which a certificate of conformity is furnished, is \$9.93.

(d) Each importer must pay a fee based upon the direct and indirect costs the agency incurs for receipt, processing, handling, and disbursement of cash deposits or obligations of the United States in lieu of sureties on bonds that the importer submits as authorized by §591.10 of this chapter in lieu of a conformance bond required under §591.6(c) of this chapter.

(e) The fee for each vehicle imported on and after October 1, 2010, for which cash deposits or obligations of the United States are furnished in lieu of a conformance bond, is \$514.

[54 FR 40107, Sept. 29, 1989, as amended at 56 FR 49429, Sept. 30, 1991; 58 FR 51023, Sept. 30, 1993; 61 FR 51045, Sept. 30, 1996; 63 FR 45186, Aug. 25, 1998; 65 FR 56500, Sept. 19, 2000; 67 FR 60599, Sept. 26, 2002; 69 FR 52100, Aug. 24, 2004; 69 FR 57874, Sept. 28, 2004; 71 FR 43990, Aug. 3, 2006; 73 FR 39896, July 11, 2008; 75 FR 48613, Aug. 11, 2010]

§594.10 Fee for review and processing of conformity certificate.

(a) Each registered importer shall pay a fee based on the agency's direct

and indirect costs for the review and processing of each certificate of conformity furnished to the Administrator pursuant to § 591.7(e) of this chapter.

(b) The direct costs attributable to the review and processing of a certificate of conformity include the estimated cost of contract and professional staff time, computer usage, and record assembly, marking, shipment and storage costs.

(c) The indirect costs attributable to the review and processing of a certificate of conformity include a pro rata allocation of the average benefits of persons employed in reviewing and processing the certificates, and a pro rata allocation of the costs attributable to the rental and maintenance of office space and equipment, the use of office supplies, and other overhead items.

(d) The review and processing fee for each certificate of conformity submitted on and after October 1, 2010 is \$17. However, if the vehicle covered by the certificate has been entered electronically with the U.S. Department of Homeland Security through the Automated Broker Interface and the registered importer submitting the certificate has an e-mail address, the fee for the certificate is \$6, provided that the fee is paid by a credit card issued to the registered importer. If NHTSA finds that the information in the entry or the certificate is incorrect, requiring further processing, the processing fee shall be \$57.

[62 FR 50882, Sept. 29, 1997, as amended at 63 FR 45186, Aug. 25, 1998; 65 FR 56500, Sept. 19, 2000; 67 FR 60599, Sept. 26, 2002; 69 FR 57874, Sept. 28, 2004; 71 FR 43990, Aug. 3, 2006; 73 FR 54986, Sept. 24, 2008; 75 FR 48613, Aug. 11, 2010]

PART 595—MAKE INOPERATIVE EXEMPTIONS

Subpart A—General

- Sec.
- 595.1 Scope.
- 595.2 Purpose.
- 595.3 Applicability.
- 595.4 Definitions.

Subpart B—Retrofit On-Off Switches for Air Bags

- 595.5 Requirements.

Subpart C—Vehicle Modifications To Accommodate People With Disabilities

- 595.6 Modifier identification.
- 595.7 Requirements for vehicle modifications to accommodate people with disabilities.

APPENDIX A TO PART 595—INFORMATION BROCHURE.

APPENDIX B TO PART 595—REQUEST FORM.

APPENDIX C TO PART 595—INSTALLATION OF AIR BAG ON-OFF SWITCHES.

AUTHORITY: 49 U.S.C. 322, 30111, 30115, 30117, 30122 and 30166; delegation of authority at 49 CFR 1.50.

SOURCE: 62 FR 62442, Nov. 21, 1997, unless otherwise noted.

Subpart A—General

§ 595.1 Scope.

This part establishes conditions under which the compliance of motor vehicles and motor vehicle equipment with the Federal motor vehicle safety standards may be made inoperative.

[66 FR 12655, Feb. 27, 2001]

§ 595.2 Purpose.

The purpose of this part is to provide an exemption from the “make inoperative” provision of 49 U.S.C. 30122 that permits motor vehicle dealers and motor vehicle repair businesses to install retrofit air bag on-off switches and to otherwise modify motor vehicles to enable people with disabilities to operate or ride as a passenger in a motor vehicle.

[66 FR 12655, Feb. 27, 2001]

§ 595.3 Applicability.

This part applies to dealers and motor vehicle repair businesses.

§ 595.4 Definitions.

The term *dealer*, defined in 49 U.S.C. 30102(a), is used in accordance with its statutory meaning.

The term *motor vehicle repair business* is defined in 49 U.S.C. 30122(a) as “a person holding itself out to the public to repair for compensation a motor vehicle or motor vehicle equipment.” This term includes businesses that receive compensation for servicing vehicles without malfunctioning or broken parts or systems by adding or removing features or components to or from

those vehicles or otherwise customizing those vehicles.

Subpart B—Retrofit On-Off Switches for Air Bags

§595.5 Requirements.

(a) Beginning January 19, 1998, a dealer or motor vehicle repair business may modify a motor vehicle manufactured before September 1, 2012 by installing an on-off switch that allows an occupant of the vehicle to turn off an air bag in that vehicle, subject to the conditions in paragraphs (b)(1) through (5) of this section.

(b)(1) The dealer or motor vehicle repair business receives from the owner or lessee of the motor vehicle a letter from the National Highway Traffic Safety Administration that authorizes the installation of an on-off switch in that vehicle for that air bag and includes a form to be filled in by the dealer or motor vehicle repair business with information identifying itself and describing the installation it makes.

(2) The dealer or motor vehicle repair business installs the on-off switch in accordance with the instructions of the manufacturer of the switch.

(3) The on-off switch meets all of the conditions specified in paragraphs (b)(3)(i) and (ii) of this section.

(i) The on-off switch is operable solely by a key or a key-like object. The on-off switch shall be separate from the ignition switch for the vehicle, so that the driver must take some action other than inserting the ignition key or turning the ignition key in the ignition switch to turn off the air bag. Once turned off, the air bag shall remain off until it is turned back on by means of the device. If a single on-off switch is installed for both air bags, the on-off switch shall allow each air bag to be turned off without turning off the other air bag. The readiness indicator required by S4.5.2 of §571.208 of this chapter shall continue to monitor the readiness of the air bags even when one or both air bags has been turned off. The readiness indicator light shall not be illuminated solely because an air bag has been deactivated by means of an on-off switch.

(ii) A telltale light in the interior of the vehicle shall be illuminated when-

ever the driver or passenger air bag is turned off by means of the on-off switch. The telltale for a driver air bag shall be clearly visible to an occupant of the driver's seating position. The telltale for a passenger air bag shall be clearly visible to occupants of all front seating positions. The telltale for an air bag:

(A) Shall be yellow;

(B) Shall have the identifying words "DRIVER AIR BAG OFF", "PASSENGER AIR BAG OFF", or "PASS AIR BAG OFF", as appropriate, on the telltale or within 25 millimeters of the telltale;

(C) Shall remain illuminated for the entire time that the air bag is "off;"

(D) Shall not be illuminated at any time when the air bag is "on;" and,

(E) Shall not be combined with the readiness indicator required by S4.5.2 of §571.208 of this chapter.

(4) The dealer or motor vehicle repair business provides the owner or lessee with an insert for the vehicle owner's manual that—

(i) Describes the operation of the on-off switch,

(ii) Lists the risk groups on the request form set forth in appendix B of this Part,

(iii) States that an on-off switch should only be used to turn off an air bag for a member of one of those risk groups, and

(iv) States the safety consequences for using the on-off switch to turn off an air bag for persons who are not members of any of those risk groups. The description of those consequences includes information, specific to the make, model and model year of the owner's or lessee's vehicle, about any seat belt energy managing features, e.g., load limiters, that will affect seat belt performance when the air bag is turned off.

(5) In the form included in the agency authorization letter specified in paragraph (b)(1) of this section, the dealer or motor vehicle repair business fills in information describing itself and the on-off switch installation(s) it makes in the motor vehicle. The dealer or motor vehicle repair business then sends the form to the address below within 7 working days after the completion of the described installations:

Nat'l Highway Traffic Safety Admin., DOT

§ 595.7

National Highway Traffic Safety Administration, Attention: Air Bag Switch Request Forms, 400 Seventh Street, S.W., Washington, D.C. 20590-1000.

[62 FR 62442, Nov. 21, 1997; 62 FR 67754, Dec. 30, 1997, as amended at 65 FR 30770, May 12, 2000; 69 FR 31034, June 2, 2004]

Subpart C—Vehicle Modifications To Accommodate People With Disabilities

SOURCE: 66 FR 12655, Feb. 27, 2001, unless otherwise noted.

§ 595.6 Modifier identification.

(a) Any motor vehicle repair business that modifies a motor vehicle to enable a person with a disability to operate, or ride as a passenger in, the motor vehicle and intends to avail itself of the exemption provided in 49 CFR 595.7 shall furnish the information specified in paragraphs (a)(1) through (3) of this section to: Administrator, National Highway Traffic Safety Administration, 1200 New Jersey Avenue, SE., Washington, DC 20590.

(1) Full individual, partnership, or corporate name of the motor vehicle repair business.

(2) Residence address of the motor vehicle repair business and State of incorporation if applicable.

(3) A statement that the motor vehicle repair business modifies a motor vehicle to enable a person with a disability to operate, or ride as a passenger in, the motor vehicle and intends to avail itself of the exemption provided in 49 CFR 595.7.

(b) Each motor business repair business required to submit information under paragraph (a) of this section shall submit the information not later than August 27, 2001. After that date, each motor business repair business that modifies a motor vehicle to enable a person with a disability to operate, or ride as a passenger in, the motor vehicle and intends to avail itself of the exemption provided in 49 CFR 595.7 shall submit the information required under paragraph (a) not later than 30 days after it first modifies a motor vehicle to enable a person with a disability to operate, or ride as a pas-

senger in, the motor vehicle. Each motor vehicle repair business who has submitted required information shall keep its entry current, accurate and complete by submitting revised information not later than 30 days after the relevant changes in the business occur.

[66 FR 12655, Feb. 27, 2001, as amended at 75 FR 47489, Aug. 6, 2010]

§ 595.7 Requirements for vehicle modifications to accommodate people with disabilities.

(a) Any motor vehicle repair business that modifies a motor vehicle to enable a person with a disability to operate, or ride as a passenger in, the motor vehicle is exempted from the “make in-operative” prohibition of 49 U.S.C. 30122 to the extent that those modifications affect the motor vehicle’s compliance with the Federal motor vehicle safety standards or portions thereof specified in paragraph (c) of this section. Modifications that would take a vehicle out of compliance with any other Federal motor vehicle safety standards, or portions thereof, are not covered by this exemption.

(b) Any motor vehicle repair business that modifies a motor vehicle to enable a person with a disability to operate, or ride as a passenger in, the motor vehicle in such a manner as to make in-operative any part of a device or element of design installed on or in the motor vehicle in compliance with a Federal motor vehicle safety standard or portion thereof specified in paragraph (c) of this section must affix to the motor vehicle a permanent label of the type and in the manner described in paragraph (d) of this section and must provide and retain a document of the type and in the manner described in paragraph (e) of this section.

(c)(1) 49 CFR 571.101, except for S5.2.1, S5.3.1, S5.3.4, S5.4.1, and S5.4.3 of that section.

(2) S5.1.1.5 of 49 CFR 571.108, in the case of a motor vehicle that is modified to be driven without a steering wheel or for which it is not feasible to retain the turn signal canceling device installed by the vehicle manufacturer.

(3) S5.1.2 and S5.1.3 of 49 CFR 571.114, in any case in which the original key locking system must be modified.

§595.7

49 CFR Ch. V (10–1–10 Edition)

(4) S4(a) of 49 CFR 571.118, in any case in which the medical condition of the person for whom the vehicle is modified necessitates the installation of a remote ignition switch to start the vehicle.

(5) S5.1 and S5.2.1 of 49 CFR 571.123, in any case in which the modification necessitates the relocation of original equipment manufacturer's controls.

(6) S5.3.1 of 49 CFR 571.135, in any case in which the modification necessitates the removal of the original equipment manufacturer foot pedal.

(7) 49 CFR 571.201 with respect to:

(i) Targets located on the right side rail, the right B-pillar and the first right side "other" pillar adjacent to the stowed platform of a lift or ramp that stows vertically, inside the vehicle.

(ii) Targets located on the left side rail, the left B-pillar and the first left side "other" pillar adjacent to the stowed platform of a lift or ramp that stows vertically, inside the vehicle.

(iii) Targets located on the rear header and the rearmost pillars adjacent to the stowed platform of a lift or ramp that stows vertically, inside the vehicle.

(iv) Targets located on any hand grip or vertical stanchion bar.

(v) All of S6 of 571.201 in any case in which the disability necessitates raising the roof or door, or lowering the floor of the vehicle.

(8) 49 CFR 571.202, in any case in which:

(i) A motor vehicle is modified to be operated by a driver seated in a wheelchair and no other seat is supplied with the vehicle for the driver;

(ii) A motor vehicle is modified to transport a right front passenger seated in a wheelchair and no other right front passenger seat is supplied with the vehicle; or

(9) S4.3(b)(1) and (2) of 49 CFR 571.202, in any case in which the driver's head restraint must be modified to accommodate a driver with a disability.

(10) S5.1 of 49 CFR 571.203, in any case in which the modification necessitates a structural change to, or removal of, the original equipment manufacturer steering shaft.

(11) S5.2 of 49 CFR 571.203, in any case in which an item of adaptive equip-

ment must be mounted on the steering wheel.

(12) 49 CFR 571.204, in any case in which the modification necessitates a structural change to, or removal of, the original equipment manufacturer steering shaft.

(13) S4.1 of 49 CFR 571.207, in any case in which a vehicle is modified to be driven by a person seated in a wheelchair and no other driver's seat is supplied with the vehicle, provided that a wheelchair securement device is installed at the driver's position.

(14) S4.1.5.1(a)(1), S4.1.5.1(a)(3), S4.2.6.2, S5, S7.1, S7.2, S7.4, S14, S15, S16, S17, S18, S19, S20, S21, S22, S23, S24, S25, S26 and S27 of 49 CFR 571.208 for the designated seating position modified, provided Type 2 or Type 2A seat belts meeting the requirements of 49 CFR 571.209 and 571.210 are installed at that position.

(15) S5 of 49 CFR 571.214 for the designated seating position modified, in any cases in which the restraint system and/or seat at that position must be changed to accommodate a person with a disability.

(16) 49 CFR 571.225 in any case in which an existing child restraint anchorage system, or built-in child restraint system relied upon for compliance with 571.225 must be removed to accommodate a person with a disability, provided the vehicle contains at least one tether anchorage which complies with 49 CFR 571.225 S6, S7 and S8 in one of the rear passenger designated seating positions. If no rear designated seating position exists after the vehicle modification, a tether anchorage complying with the requirements described above must be located at a front passenger seat. Any tether anchorage attached to a seat that is relocated shall continue to comply with the requirements of 49 CFR 571.225 S6, S7 and S8.

(d) The label required by paragraph (b) of this section shall:

(1) Be permanently affixed to the vehicle,

(2) Be located adjacent to the original certification label or the alterer's certification label, if applicable,

(3) Give the modifier's name and physical address,

Nat'l Highway Traffic Safety Admin., DOT

§ 595.7

(4) Contain the statement “This vehicle has been modified in accordance with 49 CFR 595.6 and may no longer comply with all Federal Motor Vehicle Safety Standards in effect at the time of its original manufacture.”

(e) The document required by paragraph (b) of this section shall:

(1) Be provided, in original or photocopied form, to the owner of the vehicle at the time the vehicle is delivered to the owner,

(2) Be kept, in original or photocopied form, at the same address provided on the label described in paragraph (c) of this section for a period not less than five years after the vehicle, as modified, is delivered to the individual for whom the modifications were performed,

(3) Be clearly identifiable as to the vehicle that has been modified,

(4) Contain a list of the Federal motor vehicle safety standards or portions thereof specified in paragraph (c) of this section with which the vehicle may no longer be in compliance.

(5) Indicate any reduction in the load carrying capacity of the vehicle of more than 100 kg (220 lb) after the modifications are completed. In providing this information, the modifier must state whether the weight of a user's wheelchair is included in the available load capacity.

[66 FR 12655, Feb. 27, 2001, as amended at 69 FR 21069, Apr. 20, 2004; 70 FR 51678, Aug. 31, 2005; 75 FR 47489, Aug. 6, 2010]

APPENDIX A TO PART 595--INFORMATION BROCHURE



U. S. DEPARTMENT OF TRANSPORTATION
NATIONAL HIGHWAY TRAFFIC SAFETY ADMINISTRATION

**AIR BAGS AND ON-OFF SWITCHES
INFORMATION FOR AN INFORMED DECISION**

**Keeping the Benefits for the Many
and
Reducing the Risks for the Few**

INTRODUCTION

Air bags are proven, effective safety devices. From their introduction in the late 1980's through November 1, 1997, air bags saved about 2,620 people. The number of people saved increases each year as air bags become more common on America's roads.

However, the number of lives saved is not the whole story. Air bags are particularly effective in preventing life-threatening and debilitating head and chest injuries. A study of real-world crashes conducted by the National Highway Traffic Safety Administration (NHTSA) found that the combination of seat belts and air bags is 75 percent effective in preventing serious head injuries and 66 percent effective in preventing serious chest injuries. That means 75 of every 100 people who would have suffered a serious head injury in a crash, and 66 out of 100 people who would have suffered chest injuries, were spared that fate because they wore seat belts and had air bags.

For some people, these life saving and injury-preventing benefits come at the cost of a less severe injury caused by the air bag itself. Most air bag injuries are minor cuts, bruises, or abrasions and are far less serious than the skull fractures and brain injuries that air bags prevent. However, 87 people have been killed by air bags as of November 1, 1997. These deaths are tragic, but rare events -- there have been about 1,800,000 air bag deployments as of that same date.

The one fact that is common to all who died is NOT their height, weight, sex, or age. Rather, it is the fact that they were too close to the air bag when it started to deploy. For some, this occurred because they were sitting too close to the air bag. More often this occurred because they were not restrained by seat belts or child safety seats and were thrown forward during pre-crash braking.

The vast majority of people can avoid being too close and can minimize the risk of serious air bag injury by making simple changes in behavior. Shorter drivers can adjust their seating position. Front seat adult passengers can sit a safe distance from their air bag. Infants and children 12 and under should sit in the back seat. And everyone can buckle up. The limited number of people who may not be able to make these changes may benefit from having the opportunity to turn off their air bags when necessary.

APPENDIX A TO PART 595—INFORMATION BROCHURE

Beginning January 19, 1998, consumers can choose to have an on-off switch installed for the air bags in their vehicle if they are, or a user of their vehicle is, in a risk group listed below. The following information provides the facts you need about air bags so you can make the appropriate decision for you and anyone else who is in a risk group.

What is an on-off switch?

An on-off switch allows an air bag to be turned on and off. The on-off switch can be installed for the driver, passenger, or both. To limit misuse, a key must be used to operate the on-off switch. When the air bag is turned off, a light comes on. There is a message on or near the light saying "DRIVER AIR BAG OFF" or "PASSENGER AIR BAG OFF." The air bag will remain off until the key is used to turn it back on.

What steps can you take to reduce air bag risk without buying an on-off switch?

- **Always place an infant in a rear-facing infant seat in the back seat.**
- **Always transport children 1 to 12 years old in the back seat and use appropriate child restraints.**
- **Always buckle your seat belt.**
- **Keep 10 inches between the center of the air bag cover and your breastbone.**

The vast majority of people don't need an on-off switch. Almost everyone over age 12 is much safer with air bags than without them. This includes short people, tall people, older people, pregnant women -- in fact, all people, male or female, who buckle their seat belts and who can sit far enough back from their air bag. Ideally, you should sit with at least 10 inches between the center of your breastbone and the cover of your air bag. The nearer you can come to achieving the 10-inch distance, the lower your risk of being injured by the air bag and the higher your chance of being saved by the air bag. If you can get back almost 10 inches, the air bag will still help you in a crash.

Who should consider installing an on-off switch?

- People who must transport infants riding in rear-facing infant seats in the front passenger seat.
- People who must transport children ages 1 to 12 in the front passenger seat.
- Drivers who cannot change their customary driving position and keep 10 inches between the center of the steering wheel and the center of their breastbone.
- People whose doctors say that, due to their medical condition, the air bag poses a special risk that outweighs the risk of hitting their head, neck or chest in a crash if the air bag is turned off.

If you cannot certify that you are, or any user of your vehicle is, in one of these groups, you are not eligible for an on-off switch. Turning off your air bag will not benefit you or the other users of your vehicle. Instead, it will increase the risk that you and the other users will suffer a head, neck or chest injury by violently striking the steering wheel or dashboard in a moderate to severe

crash.

WHY SOME PEOPLE ARE AT RISK

How do air bag deaths occur?

Air bags are designed to save lives and prevent injuries by cushioning occupants as they move forward in a front-end crash. By providing a cushion, an air bag keeps the occupant's head, neck, and chest from hitting the steering wheel or dashboard. To perform well, an air bag must deploy quickly. The force is greatest in the first 2-3 inches after the air bag bursts through its cover and begins to inflate. Those 2-3 inches are the "risk zone." The force decreases as the air bag inflates farther.

Occupants who are very close to or on top of the air bag when it begins to inflate can be hit with enough force to suffer serious injury or death. However, occupants who are properly restrained and sit 10 inches away from the air bag cover will contact the air bag only after it has completely or almost completely inflated. The air bag then will cushion and protect them from hitting the hard surfaces in the vehicle.

Do both children and adults face risk?

Yes, both children and adults face the risk of air bag injury or death if they are positioned too close to the air bag or fail to use proper restraints. As of November 1, 1997, NHTSA has confirmed that 49 young children have died, all on the passenger side. 38 adults have died -- 35 drivers and 3 passengers.

What were the specific circumstances of the children's deaths?

Almost all of the 49 children who died were improperly restrained or positioned. 12 were infants under age 1 who were riding in rear-facing infant seats in front of the passenger air bag. When placed in the front seat, a rear-facing infant seat places an infant's head within a very few inches of the passenger air bag. In this position, an infant is almost certain to be injured if the air bag deploys. Rear-facing infant seats must ALWAYS be placed in the back seat.

The other 37 children ranged in age from 1 to 9 years; most were 7 or under. 29 of them were totally unrestrained. This includes 4 children who were sitting on the laps of other occupants. The remaining 8 children included some who were riding with their shoulder belts behind them and some who were wearing lap and shoulder belts but who also should have been in booster seats because of their small size and weight. Booster seat use could have improved shoulder belt fit and performance. These various factors allowed the 37 children to get too close to the air bag when it began to inflate.

What were the specific circumstances of the adults' deaths?

Most of the adults who were killed by air bags were not properly restrained. 18 of the 35 drivers, and 2 of the 3 passengers, were totally unbelted. 2 of the drivers who were belted had medical conditions which caused them to slump over the steering wheel immediately before the crash. A few of the drivers did not use their seat belts correctly and the others are believed to have been sitting too close to the steering wheel.

SEE FOR YOURSELF

Visit the NHTSA Web site at <http://www.nhtsa.dot.gov> and click on the icon "AIR BAGS - Information about air bags." A video shows crash tests of properly belted dummies whose air bags are turned off. A properly belted short female dummy without an air bag is shown slamming her head hard enough to bend the steering wheel and suffer fatal injuries. For more information, call the NHTSA Hotline at 1-800-424-9393.

REDUCING THE RISK**What is the safest way to ride in front of an air bag?**

First, move the seat back and buckle up -- every time, every trip. The lap belt needs to fit over your hips, not your abdomen, and the shoulder belt should lie on your chest and over your shoulder. Remove any slack from the belt. In a crash, seat belts stretch and slow down your movement toward the steering wheel or dashboard. Moving back and properly using seat belts give the air bag a chance to inflate before you move forward in a crash far enough to contact the air bag.

How do I best protect children?

Never place a rear-facing infant seat in the front seat if the air bag is turned on. Always secure a rear-facing seat in the back seat. Children age 12 and under should ride in the back seat. While almost all of the children killed by an air bag were 7 years old or younger, a few older children have been killed. Accordingly, age 12 is recommended to provide a margin of safety.

There are instances when children must sit in the front because the vehicle has no rear seat, there are too many children for all to ride in back, or a child has a medical condition that requires monitoring. If children must sit in the front seat, they should use the seat belts and/or child restraint appropriate for their weight or size (see the table at the end of this brochure) and sit against the back of the vehicle seat. The vehicle seat should be moved as far back from the air bag as practical. Make sure the child's shoulder belt stays on. If adult seat belts do not fit properly, use a booster seat. Also, children must never ride on the laps of others.

What should teenagers and adults do to be safest on the passenger side?

Always wear seat belts. This reduces the distance that they can move forward during a crash. Move the seat toward the rear. The distance between a passenger's chest and the dashboard where the air bag is stored is usually more than 10 inches, even with the passenger seat all the way forward. But more distance is safer.

How do I stay safe when I'm driving?

Since the risk zone for driver air bags is the first 2-3 inches of inflation, placing yourself 10 inches from your driver air bag provides you with a clear margin of safety. This distance is measured from the center of the steering wheel to your breastbone. If you now sit less than 10 inches away, you can change your driving position in several ways:

- Move your seat to the rear as far as you can while still reaching the pedals comfortably.

- Slightly recline the back of the seat. Although vehicle designs vary, many drivers can achieve the 10-inch distance, even with the driver seat all the way forward, simply by reclining the back of the seat somewhat. If reclining the back of your seat makes it hard to see the road, raise yourself by using a firm, non-slippery cushion, or raise the seat if your vehicle has that feature.
- If your steering wheel is adjustable, tilt it downward. This points the air bag toward your chest instead of your head and neck.

[In its published version, the brochure will be 10 inches tall and will indicate that it should be placed between your breastbone and the center of the air bag cover to check your distance.]

Will following these safety tips guarantee that I will be safe in a crash?

There is no guarantee of safety in a crash, with or without an air bag. However, most of the people killed by air bags would not have been seriously injured if they had followed these safety tips.

Are air bags the reason the back seat is the safest place for children?

No. The back seat has always been safer, even before there were air bags. NHTSA conducted a study of children who died in crashes in the front and back seats of vehicles, very few of which had passenger air bags. The study concluded that placing children in the back reduces the risk of death in a crash by 27 percent, whether or not a child is restrained.

THE ON-OFF SWITCH DECISION

Vehicle owners and lessees can obtain an on-off switch for one or both of their air bags only if they can certify that they are, or a user of their vehicle is, in one of the four risk groups listed below:

Two risk groups have a high enough risk that they would definitely be better off with an on-off switch:

- **Infants in rear-facing infant seats.** A rear-facing infant seat must never be placed in the front seat unless the air bag is turned off.
- **Drivers or passengers with unusual medical conditions.** These are people who have been advised by a physician that an air bag poses a special risk to them because of their condition. However, they should not turn off their air bag unless their physician also has advised them that this risk is greater than what may happen if they do turn off their air bag. Without an air bag, even belted occupants could hit their head, neck or chest in a crash.

A national conference of physicians considered all medical conditions commonly cited as possible justifications for turning off air bags. The physicians did not recommend turning off air bags for persons with pacemakers, supplemental oxygen, eyeglasses, median sternotomy, angina, chronic obstructive pulmonary disease, emphysema, asthma, breast reconstruction, mastectomy, scoliosis (if the person can be positioned properly), previous back or neck surgery, previous facial reconstructive surgery or facial injury, hyperacusis, tinnitus, advanced age,

osteogenesis imperfecta, osteoporosis & arthritis (if the person can sit at a safe distance from the air bag), previous ophthalmologic surgery, Down syndrome and atlantoaxial instability (if the person can reliably sit properly aligned), or pregnancy. The physicians recommended turning off an air bag if a safe sitting distance or position cannot be maintained by a driver because of scoliosis or achondroplasia or by a passenger because of scoliosis or Down syndrome and atlantoaxial instability. The physicians also noted that a passenger air bag might have to be turned off if an infant or child has a medical condition and must ride in front so that he or she can be monitored. To obtain a copy of the recommendations, call the NHTSA Hotline or see the NHTSA Web site.

Two other risk groups may be better off with an air bag on-off switch:

- **Children ages 1 to 12.** Children in this age group can be transported safely in the front seat if they are properly belted, they do not lean forward, and their seat is moved all the way back. The vast majority of all fatally injured children in this age range were completely unrestrained. But children sometimes sit or lean far forward and may slip out of their shoulder belts, putting themselves at risk. The simple act of leaning far forward to change the radio station can momentarily place even a belted child in danger. If a vehicle owner must transport a child in the front seat, the owner is eligible for an on-off switch for the passenger air bag. Since air bag performance differs from vehicle model to vehicle model, the vehicle owner may wish to consult the vehicle manufacturer for additional advice.

CAUTION: If you allow children to ride in the front seat while unrestrained or improperly restrained, and especially if you sit with a child on your lap, **you are putting them at serious risk, with or without an air bag**. Turning off the air bag is not the safe answer. It would eliminate air bag risk but not the likelihood that in a crash an unrestrained child would fly through the air and strike the dashboard or windshield, or be crushed by your body.

- **Drivers who cannot get back 10 inches.** Very few drivers are unable to sit so that their breastbone is 10 inches away from their air bag. If, despite your best efforts, you cannot maintain a distance of 10 inches, you may wish to **consult your dealer or vehicle manufacturer for advice or modifications to help you move back**.

Since the risk zone is the first 2-3 inches from the air bag cover, sitting back 10 inches provides a clear margin of safety. While getting back at least 10 inches is desirable, if you can get back almost 10 inches, the air bag is unlikely to seriously injure you in a crash and you probably don't need an on-off switch. If you cannot get back almost 10 inches from the air bag cover, you may wish to consider an on-off switch. Since air bag performance differs among vehicle models, you may wish to consult your vehicle manufacturer for additional advice.

What if you are, or a user of your vehicle is, not in one of the listed risk groups?

You are not at risk and do not need an on-off switch. This includes short people, tall people, older people, pregnant women -- in fact, all people, male or female over age 12, who buckle their seat belts and who can sit with 10 inches from the center of their breastbone to where the air bag is stored. You will have the full benefit of your air bag and will minimize the risk of violently striking the steering wheel and dashboard in a moderate to severe crash.

How do I get an on-off switch?

If you are eligible, you must fill out a NHTSA request form. Forms are available at state motor vehicle offices and may be available at automobile dealers and repair shops. You may also get one by calling the NHTSA Hotline or visiting the NHTSA Web site. On the form, you must indicate which air bags you want equipped with an on-off switch, certify that you have read this information brochure, certify that you are, or a user of your vehicle is, a member of a risk group listed above, and identify the group. Then send this form to NHTSA. Upon approval of your request, the agency will send you a letter authorizing an automobile dealer or repair shop to install an on-off switch in your vehicle.

Should a pregnant woman get an on-off switch?

No, not unless she is a member of a risk group. Pregnant women should follow the same advice as other adults: buckle up and stay back from the air bag. The lap belt should be positioned low on the abdomen, below the fetus, with the shoulder belt worn normally. Pull any slack out of the belt. Just as for everyone else, the greatest danger to a pregnant woman comes from slamming her head, neck or chest on the steering wheel in a crash. When crashes occur, the fetus can be injured by striking the lower rim of the steering wheel or from crash forces concentrated in the area where a seat belt crosses the mother's abdomen. By helping to restrain the upper chest, the seat belt will keep a pregnant woman as far as possible from the steering wheel. The air bag will spread out the crash forces that would otherwise be concentrated by the seat belt.

ON-OFF SWITCH PRECAUTIONS**If I turn off my air bag for someone at risk, what precautions should I take for others?**

Since the air bag will not automatically turn itself back on after you turn it off with an on-off switch, you must remember to turn it on when someone who is not at risk is sitting in that seat. Every on-off switch has a light to remind you when the air bag is turned off.

If I turn off my air bag, will my seat belts provide enough protection?

Air bags increase the protection you can get from seat belts alone. If the air bag is turned off, you lose this extra protection.

In some newer vehicles, turning off your air bag may have additional consequences. These vehicles have seat belts that were specially designed to work together with air bags. If the crash forces become too great, these new seat belts "give" or yield to avoid concentrating too much force on your chest. The air bag prevents you from moving too far forward after the seat belts

give. Without the air bag to cushion this forward movement, the chance of the occupant hitting the vehicle interior is increased.

Ask your vehicle manufacturer whether your seat belts were specially designed to work with an air bag. If they were, your dealer or repair shop will provide you information about the effects that turning off your air bag will have on the performance of the belts. Ask your dealer or repair shop to show you this information before you decide whether to have an on-off switch installed.

HOW AIR BAGS WORK

Air bags are designed to keep your head, neck, and chest from slamming into the dash, steering wheel or windshield in a front-end crash. They are not designed to inflate in rear-end or rollover crashes or in most side crashes. Generally, air bags are designed to deploy in crashes that are equivalent to a vehicle crashing into a solid wall at 8-14 mph. Air bags most often deploy when a vehicle collides with another vehicle or with a solid object like a tree.

Air bags inflate when a sensor detects a front-end crash. The sensor sends an electric signal to start a chemical reaction that inflates the air bag with harmless nitrogen gas. All this happens faster than the blink of an eye. Air bags have vents, so they deflate immediately after cushioning you. They cannot smother you and they don't restrict your movement. The "smoke" you may have seen in a vehicle after an air bag demonstration is the nontoxic starch or talc that is used to lubricate the air bag.

Are all air bags the same?

No. Air bags differ in design and performance. There are differences in the crash speeds that trigger air bag deployment, the speed and force of deployment, the size and shape of air bags, and the manner in which they unfold and inflate. That is why you should contact your vehicle manufacturer if you want specific information about the air bags in your particular car or truck.

FUTURE AIR BAGS

Do I need an on-off switch if I buy a vehicle with depowered air bags?

Many manufacturers are installing depowered air bags beginning with their model year 1998 vehicles. They are called "depowered" because they deploy with less force than current air bags. They will reduce the risk of air bag-related injuries. However, even with depowered air bags, rear-facing child seats still should never be placed in the front seat and children are still safest in the back seat. Contact your vehicle manufacturer for further information.

Will on-off switches be necessary in the future?


Manufacturers are actively developing so-called "smart" or "advanced" air bags that may be able to tailor deployment based on crash severity, occupant size and position, or seat belt use. These bags should eliminate the risks produced by current air bag designs. It is likely that vehicle manufacturers will introduce some form of advanced air bags over the next few years.

WHAT RESTRAINT IS RIGHT FOR YOUR CHILD?

Weight or size of your child	Proper type of restraint (Put your child in back seat, if possible)
Children less than 20 pounds,* or less than 1 year	Rear-facing infant seat <i>(secured to the vehicle by the seat belts)</i>
Children from about 20 to 40 pounds* and at least 1 year	Forward-facing child seat <i>(secured to the vehicle by the seat belts)</i>
Children more than 40 pounds*	Booster seat, plus <u>both</u> portions of a lap/shoulder belt <i>(except only the lap portion is used with some booster seats equipped with front shield)</i>
Children who meet both criteria below: (1) Their sitting height is high enough so that they can, without the aid of a booster seat: wear the shoulder belt comfortably across their shoulder, and secure the lap belt across their pelvis, <u>and</u> (2) Their legs are long enough to bend over the front of the seat when their backs are against the <u>vehicle seat back</u>	<u>Both</u> portions of a lap/shoulder belt

* To determine whether a particular restraint is appropriate for your child, see restraint manufacturer's recommendations concerning the weight of children who may safely use the restraint.

APPENDIX B TO PART 595--REQUEST FORM

	U. S. DEPARTMENT OF TRANSPORTATION	OMB No. 2127-0588
	NATIONAL HIGHWAY TRAFFIC SAFETY ADMINISTRATION	Expiration Date: 11/30/00
REQUEST FOR AIR BAG ON-OFF SWITCH		

Vehicle Owner or Lessee Instructions:
 Read the National Highway Traffic Safety Administration (NHTSA) information brochure, "Air Bags & On-Off Switches, Information for an Informed Decision." If you want authorization for an on-off switch for your driver air bag, passenger air bag, or both, fill out Parts A, B, E and F completely, fill out Parts C and D as appropriate, and send this form to:
 National Highway Traffic Safety Administration
 Attention: Air Bag Switch Request Forms
 400 Seventh Street, S. W.
 Washington, D.C. 20590-1000

- Please print.
- Please note: Incomplete forms will be returned to the owner or lessee.
- If you need a copy of the brochure or have any questions about how to fill out this form, call the NHTSA Hotline at 1-800-424-9393.

Part A. Name and address			

(First)		(Middle In.)	(Last)
Residence: Street address	City	State	Zip Code

Part B. I own or lease the following vehicle: (Owners of multiple vehicles should consult the additional instructions at the end of this form.)																						
Make	Model																					
Model year	Vehicle Identification Number (located on driver's side of dashboard near windshield and on certification label on driver's door frame)																					
	<table border="1" style="width: 100%; height: 15px;"> <tr> <td></td><td></td><td></td><td></td><td></td><td></td><td></td><td></td><td></td><td></td><td></td><td></td><td></td><td></td><td></td><td></td><td></td><td></td><td></td><td></td><td></td> </tr> </table>																					

APPENDIX B TO PART 595—REQUEST FORM

<p>Part C. Switch for Driver Air Bag. I request authorization for the installation of an on-off switch for the driver air bag in my vehicle. I certify that I or another driver of my vehicle meets the criteria for the risk group checked below. (At least one box must be checked.)</p>	
<input type="checkbox"/>	<p>Medical condition. The driver has a medical condition which, according to his or her physician:</p> <ul style="list-style-type: none"> • causes the driver air bag to pose a special risk for the driver; and • makes the potential harm from the driver air bag in a crash greater than the potential harm from turning off the air bag and allowing the driver, even if belted, to hit the steering wheel or windshield in a crash.
<input type="checkbox"/>	<p>Distance from driver air bag. Despite taking all reasonable steps to move back from the driver air bag, the driver is not able to maintain a 10-inch distance from the center of his or her breastbone to the center of the driver air bag cover.</p>
<p>Part D. Switch for Passenger Air Bag. I request authorization for the installation of an on-off switch for the passenger air bag in my vehicle. I certify that I or another passenger of my vehicle meets the criteria for the risk group checked below. (At least one box must be checked.)</p>	
<input type="checkbox"/>	<p>Infant. An infant (less than 1 year old) must ride in the front seat because:</p> <ul style="list-style-type: none"> • my vehicle has no rear seat; • my vehicle has a rear seat too small to accommodate a rear-facing infant seat; or • the infant has a medical condition which, according to the infant's physician, makes it necessary for the infant to ride in the front seat so that the driver can constantly monitor the child's condition.
<input type="checkbox"/>	<p>Child age 1 to 12. A child age 1 to 12 must ride in the front seat because:</p> <ul style="list-style-type: none"> • my vehicle has no rear seat; • although children ages 1 to 12 ride in the rear seat(s) whenever possible, children ages 1 to 12 sometimes must ride in the front because no space is available in the rear seat(s) of my vehicle; or • the child has a medical condition which, according to the child's physician, makes it necessary for the child to ride in the front seat so that the driver can constantly monitor the child's condition.
<input type="checkbox"/>	<p>Medical condition. A passenger has a medical condition which, according to his or her physician:</p> <ul style="list-style-type: none"> • causes the passenger air bag to pose a special risk for the passenger; and • makes the potential harm from the passenger air bag in a crash greater than the potential harm from turning off the air bag and allowing the passenger, even if belted, to hit the dashboard or windshield in a crash.

Part E. I make this request based on following certification and understandings:	
(Check each box below after reading carefully.)	
<input type="checkbox"/>	Information brochure. I certify that I have read the NHTSA information brochure, "Air Bags & On-Off Switches, Information for an Informed Decision." I understand that air bags should be turned off only for people at risk and turned back on for people not at risk.
<input type="checkbox"/>	Loss of air bag protection. I understand that turning off an air bag may have serious safety consequences. When an air bag is off, even belted occupants may hit their head, neck or chest on the steering wheel, dashboard or windshield in a moderate to serious crash. That possibility may be increased in some newer vehicles with seat belts that are specially designed to work with the air bag. Those belts, which are designed to reduce the concentration of crash forces on any single part of the body, typically allow the occupant to move farther forward in a crash than older belts. Without the air bag to cushion this forward movement, the chance of the occupant hitting the vehicle interior is increased.
<input type="checkbox"/>	Waiver. I understand that motor vehicle dealers and repair businesses may require me to sign a waiver of liability before they install an on-off switch.

Part F. Certification.	
I certify to the U. S. Department of Transportation that the information, certifications and understandings given or indicated by me on this form are truthful, correct and complete to the best of my knowledge and belief. I recognize that the statements I have made on this form concern a matter within the jurisdiction of a department of the United States and that making a false, fictitious or fraudulent statement may render me subject to criminal prosecution under Title 18, United States Code, Section 1001.	
Date	Signature of owner/lessee

Additional instructions and information for vehicle owners and lessees: An owner or lessee of multiple vehicles (e.g., a fleet owner) who wants an on-off switch for the same air bag (e.g., just the passenger air bag) in more than one vehicle and for the same reason does not need to submit a separate form for each vehicle. Instead, the owner or lessee may list the make, model, model year, and vehicle identification number for each of those vehicles and attach the list to a copy of this form. Each page of the list must be signed and dated by the owner or lessee. A list may also be attached to a single copy of this form if the owner or lessee wishes to request authorization for on-off switches for both air bags in multiple vehicles.

Please note that an agency may not conduct or sponsor, and a person is not required to respond to, a collection of information unless it displays a currently valid OMB control number. That number appears above.

APPENDIX C TO PART 595—INSTALLATION OF AIR BAG ON-OFF SWITCHES

INSTALLATION OF AIR BAG ON-OFF SWITCHES	OMB No. 2127-0588 Expiration Date: 11/30/00
--	--

(The form and instructions below will be included in agency letters sent to vehicle owners or lessees authorizing the installation of air bag on-off switches. Each letter will identify the owner or lessee and the vehicle for which installation is authorized.)

The vehicle dealer or repair business identified below made the following installations of on-off switch(es) for the air bags in the motor vehicle identified above:		
Name of motor vehicle dealer or repair business		
Street address		
City	State	Zip Code
On-off switch(es) were installed for the air bag(s) checked on this form:	driver air bag <input type="checkbox"/>	passenger air bag <input type="checkbox"/>
Date of installation	Signature of authorized representative of dealer or repair business	

Instructions for vehicle dealers and repair businesses: Within 7 days of your installation of an on-off switch in the vehicle identified above, you must complete this form and mail it to: National Highway Traffic Safety Administration, Attention: Air Bag Switch Installation Forms, 400 Seventh St., S. W., Washington, D.C. 20590-1000.

Note: An agency may not conduct or sponsor, and a person is not required to respond to, a collection of information unless it displays a currently valid OMB control number. That number appears above.

PARTS 596-598 [RESERVED]

PART 599—REQUIREMENTS AND PROCEDURES FOR CONSUMER ASSISTANCE TO RECYCLE AND SAVE ACT PROGRAM

Subpart A—General

- Sec.
- 599.100 Purpose.
- 599.101 Scope.
- 599.102 Definitions.

Subpart B—Participating Dealers, Salvage Auctions and Disposal Facilities

- 599.200 Registration of participating dealers.
- 599.201 Identification of salvage auctions and disposal facilities.

Subpart C—Qualifying Transactions and Reimbursement

- 599.300 Requirements for qualifying transactions.
- 599.301 Limitations and restrictions on qualifying transactions.
- 599.302 Dealer application for reimbursement—submission, contents.
- 599.303 Agency disposition of dealer application for reimbursement.
- 599.304 Payment to dealer.

Subpart D—Disposal of Trade-in Vehicle

- 599.400 Transfer or consignment by dealer of trade-in vehicle.
- 599.401 Requirements and limitations for disposal facilities that receive trade-in vehicles under the CARS program.
- 599.402 Requirements and limitations for salvage auctions that are consigned trade-in vehicles under the CARS program.
- 599.403 Requirements and limitations for dealers.

Subpart E—Enforcement

- 599.500 Definitions.
- 599.501 Generally.
- 599.502 Record retention.
- 599.503 Access to records.
- 599.504 Suspension, revocation, and reinstatement of registration and participation eligibility.
- 599.505 Reports and investigations.
- 599.506 Notice of violation.
- 599.507 Disclosure of evidence.
- 599.508 Statements of matters in dispute and submission of supporting information.
- 599.509 Hearing officer.
- 599.510 Initiation of action before the hearing officer.
- 599.511 Counsel.
- 599.512 Hearing location and costs.
- 599.513 Hearing procedures.
- 599.514 Assessment of civil penalties.
- 599.515 Appeals of civil penalties in excess of \$100,000.00.
- 599.516 Collection of assessed or compromised civil penalties.
- 599.517 Other sanctions.

Subpart F—Requirements and Procedures for Exceptions

- 599.600 Exceptions—Applicability and requirements.
- 599.601 Procedures for requesting exception.
- 599.603 Disposition of requests for exception.
- APPENDIX A TO PART 599—SUMMARY OF SALE/LEASE AND CERTIFICATIONS
- APPENDIX B TO PART 599—ENGINE DISABLEMENT PROCEDURES FOR THE CARS PROGRAM
- APPENDIX C TO PART 599—ELECTRONIC TRANSACTION SCREEN
- APPENDIX D TO PART 599—CARS PURCHASER SURVEY
- APPENDIX E TO PART 599—DISPOSAL FACILITY CERTIFICATION FORM
- APPENDIX F TO PART 599—SALVAGE AUCTION CERTIFICATION FORM

AUTHORITY: 49 U.S.C. 32901, Notes; delegation of authority at 49 CFR 1.50.

SOURCE: 74 FR 37897, July 29, 2009, unless otherwise noted.

Subpart A—General

§ 599.100 Purpose.

This part establishes requirements and procedures implementing the program authorized under the Consumer Assistance to Recycle and Save Act of 2009.

§ 599.101 Scope.

The requirements of this part apply to new vehicle purchase or lease transactions, in combination with trade-in vehicle transactions that occur on or after July 1, 2009 up to and including November 1, 2009, and to the disposal of trade-in vehicles under the CARS Act.

§ 599.102 Definitions.

As used in this part—

Agency or NHTSA means the National Highway Traffic Safety Administration.

CARS Act means the Consumer Assistance to Recycle and Save Act of 2009, Public Law 111-32, 123 Stat. 1859 (June 24, 2009).

CARS Program means the program authorized under the Consumer Assistance to Recycle and Save Act of 2009, which NHTSA refers to as the Car Allowance Rebate System.

Category 1 truck means a non-passenger automobile, as defined in section 49 U.S.C. 32901(a)(17) and 49 CFR 523.3, except that such term does not include a category 2 truck.

Category 2 truck means a large van with a wheelbase of 124 inches or more, or a large pickup with a wheelbase of 115 inches or more.

Category 3 truck means a work truck, as defined in 49 U.S.C. 32901(a)(19).

Clear title means title to a vehicle that is free from all liens and encumbrances.

Combined Fuel Economy means—

(1) With respect to an eligible new vehicle, the number, expressed in miles per gallon, centered below the words “Combined Fuel Economy” on the label required to be affixed or caused to be affixed on a new automobile pursuant to subpart D of 40 CFR part 600.

(2) With respect to an eligible trade-in vehicle of model year 1985 or later, the number posted under the words “Estimated New EPA MPG” or “New EPA MPG” and above the word “Combined,” except that for a bi-fuel, dual fuel, or flexible fueled vehicle, that number must also be below the word “Gasoline,” on the fueleconomy.gov Web site of the Environmental Protection Agency for the make, model, and year of such vehicle.

§ 599.200

Credit means an electronic payment to a dealer for a qualifying transaction under the program.

Dealer means a person licensed by a State who engages in the sale of a new automobile to a person who in good faith purchases such automobile for purposes other than resale.

Disposal facility means a facility listed on <http://www.cars.gov/disposal> as eligible to receive a trade-in vehicle for crushing or shredding under the CARS program, except in the case of a U.S. territory.

End-of-Life Vehicle Solutions or ELVS means an entity established under the National Vehicle Mercury Switch Recovery Program for the collection, recycling and disposal of elemental mercury from automotive switches.

Engine block means the part of the engine containing the cylinders and typically incorporating water cooling jackets and also including the crank shaft, connecting rods, pistons, bearings, cam(s), and cylinder head(s). In a rotary engine, the block includes the rotor housing and rotor.

GVWR means gross vehicle weight rating.

Lease means a lease of a new vehicle for a period of not less than 5 years, excluding any lease with a balloon payment due prior to the elapsing of 5 years.

Manufacturer's Suggested Retail Price or MSRP means the base Manufacturer's Suggested Retail Price, excluding any dealer accessories, optional equipment, taxes and destination charges.

National Motor Vehicle Title Information System or NMVTIS means the online system established under the oversight of the Department of Justice that enables consumers and others to access vehicle history information, including salvage history, total loss information, and title branding and odometer information, and to which insurance companies and salvage yards must report vehicle status information. (<http://www.nmvtis.gov>.)

New Vehicle means an automobile or work truck, the equitable or legal title of which has not been transferred to any person other than the purchaser.

Non-titling Jurisdiction means a State that does not issue a title for certain typically older vehicles.

49 CFR Ch. V (10–1–10 Edition)

Passenger automobile means a passenger automobile, as defined in section 49 U.S.C. 32901(a)(18) and 49 CFR 523.4.

Person means an individual, corporation, company, association, firm, partnership, society, or joint stock company.

Purchaser means a person purchasing or leasing a new vehicle under the CARS Program.

Salvage auction means an entity that receives a CARS trade-in vehicle from a dealer and is authorized to sell it only to a disposal facility on the Disposal Facility List and that will make all the necessary certifications for salvage auctions under the CARS program.

State means any one of the 50 United States, the District of Columbia, Puerto Rico, the Virgin Islands, Guam, American Samoa, or the Commonwealth of the Northern Mariana Islands.

Subpart B—Participating Dealers, Salvage Auctions and Disposal Facilities

§ 599.200 Registration of participating dealers.

(a) *In general.* A dealer may apply for a credit under the CARS Program only if it meets the Required Dealer Qualifications for Registration under this subpart, is registered in accordance with this subpart, and is currently registered at the time it submits an application for reimbursement.

(b) *Required dealer qualifications for registration.* A dealer seeking to register must have:

(1) A currently operating new automobile dealership and business address within a State in the United States;

(2) A currently active business license under the law of the State where the new automobile dealership is located to operate that dealership;

(3) A currently active franchise agreement to sell new automobiles with an original equipment manufacturer of automobiles;

(4) A bank account in a U.S. bank in a State and a bank account routing number for electronic transfer of funds;

(5) The ability to submit application materials and perform transactions electronically using the Internet; and

(6) Not been convicted of a crime involving motor vehicles or any fraud or financial crime under State or Federal law.

(c) *Registration procedures.*

(1) Using comprehensive lists of franchised dealers provided by original equipment manufacturers, as updated by these manufacturers, the agency will mail a letter to each listed dealer describing a secure electronic process and providing an authorization code by which the dealer, following the process in paragraph (c)(2) of this section, can effect registration.

(2) A dealer contacted in accordance with paragraph (c)(1) of this section may register electronically as a participating dealer under the CARS Program by using the authorization code and following the instructions provided in the letter mailed under paragraph (c)(1) of this section, and submitting the following information electronically or validating the information, where it exists already on an electronic form:

(i) Dealer's Federal Tax Identification Number (TIN) and OEM assigned dealer franchise number;

(ii) Legal business name, doing business as name (if applicable), dealership physical and mailing address, telephone number, and fax number;

(iii) Name and title of dealer representative authorized to submit transactions under this program, and phone number and e-mail address of representative; and

(iv) Name of U.S. bank used by dealership, bank account number, and bank account routing number.

(3) A dealer must register separately, following the process under paragraph (c)(2) of this section, for each make of vehicle it sells, using the authorization code associated with that vehicle make.

(d) *Disposition of registration application.* The agency will review the registration application for compliance with this part, including completeness, and notify the dealer as follows:

(1) For an approved registration:

(i) By e-mail notification to the authorized dealer representative, with a

user identification and password that will allow the submission of transactions; and

(ii) By listing the "doing business as" name, physical address, and general telephone number of the dealer on the agency Web site at <http://www.cars.gov>.

(2) For a disapproved registration, by withholding the dealer identification information from the agency's Web site and providing e-mail notification to the authorized dealer representative of the reasons for rejecting the application.

(e) *Revocation of Dealer Registration.*

(1) *Termination or Discontinuance of Franchise.*

(i) A dealer whose franchise agreement with an original equipment manufacturer (OEM) has expired without renewal, has been terminated, or otherwise is no longer in effect shall be automatically removed as a matter of course, subject to paragraph (e)(1)(iii), from the agency's list of registered dealers and may no longer receive a credit for new transactions under the CARS Program submitted for repayment on or after the date that the franchise expired or no longer is in effect.

(ii) Paragraph (e)(1)(i) of this section does not preclude a dealer registered under other franchise agreements from receiving a credit for transactions under those agreements that have not expired or been discontinued.

(iii) A dealer whose name is removed from the agency's list of registered dealers under paragraph (e)(1)(i) shall be reinstated to the list of registered dealers upon a showing to NHTSA of proper and adequate license to sell new vehicles to ultimate purchasers.

(2) *Other suspension or revocations actions.* The agency may also suspend or revoke the registration of a dealer as provided in § 599.504.

(f) *Notification of changes.* A registered dealer shall immediately notify the agency of any change to the information submitted under this section and any change to the status of its State license or franchise.

(g) *Pre-registration transactions.* An otherwise qualifying transaction that occurs during the time period prescribed under § 599.301(a) is not a non-complying transaction solely because a dealer is not registered at the time of

§ 599.201

the transaction, except that the dealer must be eligible to register and must register under § 599.200 in order to be entitled to reimbursement for a credit extended under the CARS program.

§ 599.201 Identification of salvage auctions and disposal facilities.

(a) *Participating entities.* Subject to the conditions and requirements of paragraph (b), participation in the transfer and disposal of a trade-in vehicle under the CARS program is limited to the following entities:

(1) A salvage auction that will transfer trade-in vehicles received under this program only to a disposal facility identified in paragraph (a)(2) or (a)(3) of this section.

(2) A disposal facility listed on the Web site at <http://www.cars.gov/disposal>; or

(3) A facility that disposes of vehicles in Puerto Rico, the Virgin Islands, Guam, American Samoa, or the Commonwealth of the Northern Mariana Islands.

(b) *Conditions of Participation.* A participating entity identified in paragraph (a) of this section must:

(1) Comply with all the provisions and restrictions and make all the required certifications contained in subpart D of this part.

(2) In the case of a disposal facility identified in paragraph (a)(2) of this section, be currently listed on the Web site at <http://www.cars.gov/disposal>, as of the date of its participation in the disposal of the trade-in vehicle.

(c) *Removal of authority to participate.*

(1) A disposal facility that qualifies as such by active membership in ELVS and that fails to maintain active ELVS membership may be automatically removed as a matter of course from the agency's list of disposal facilities maintained at <http://www.cars.gov/disposal> authorized to participate in the CARS program.

(2) The agency may also suspend or remove a salvage auction's or disposal facility's authority to participate in the CARS program in accordance with the procedures of § 599.504.

[74 FR 37897, July 29, 2009, as amended at 74 FR 38976, Aug. 5, 2009]

49 CFR Ch. V (10–1–10 Edition)

Subpart C—Qualifying Transactions and Reimbursement

§ 599.300 Requirements for qualifying transactions.

(a) *In general.* To qualify for a credit under the CARS Program, a dealer must sell or lease a new vehicle that meets eligibility requirements to a purchaser, obtain a trade-in vehicle that meets eligibility requirements from the purchaser, satisfy combined fuel economy requirements for both the new and trade-in vehicles, store the trade-in vehicle at the dealership or property owned by or under the control of the dealership until the engine is disabled, disable the engine of the trade-in vehicle at the dealership or property owned by or under the control of the dealership, satisfy the limitations and restrictions of the program, arrange for disposal of the trade-in vehicle at a qualifying disposal facility or through a qualifying salvage auction, and register and submit a complete application for reimbursement to NHTSA, demonstrating that it meets all the requirements of this part.

(b) *Threshold eligibility requirements that apply to all trade-in vehicles.* The trade-in vehicle must be:

(1) In drivable condition, as demonstrated by actual operation of the motor vehicle on public roads by the dealer and by certification by the dealer and by the purchaser, as provided in Appendix A to this part, certifications section, that the vehicle was in drivable condition on the date of the qualifying transaction;

(2) Continuously insured consistent with the applicable State law for a period of not less than 1 year immediately prior to the trade-in, as demonstrated by:

(i) One or more current insurance cards specifying the make, model, model year, and vehicle identification number (VIN) of the insured vehicle and displaying a continuous one-year period of insurance coverage; or a copy of an insurance policy document (*e.g.*, a declarations page or pages) showing a continuous one-year period of insurance coverage for the vehicle; or a signed letter, on insurance company letterhead, specifying the same vehicle identification information (*i.e.*, make,

model, model year, and VIN) of the insured vehicle and identifying the period of continuous coverage, which must be for at least one year prior to the date of the trade-in; and

(ii) By certification by the purchaser, as provided in Appendix A to this part, certifications section, that the vehicle was so insured;

(3) Continuously registered in a State to the purchaser for a period of not less than one year immediately prior to the trade-in, as demonstrated by:

(i) A current State registration document or series of registration documents in the name of the purchaser evidencing registration for a period of not less than one year immediately prior to the trade-in; or a current State registration document showing registration in the name of the purchaser and a title that confers title on the purchaser not less than one year immediately prior to the trade-in; or a current State registration document showing registration in the name of the purchaser and a document from a commercially available vehicle history provider evidencing registration for a period of not less than one year immediately prior to the trade-in; and

(ii) By certification by the purchaser, as provided in Appendix A to this part, certifications section, that the vehicle was so registered;

(4) Manufactured less than 25 years before the date of the trade-in, as demonstrated by model year information on the title or, where that information is inconclusive, by direct observation by the dealer of the month and year of the vehicle's manufacture, which appears on the safety standard certification label of the vehicle, provided that on the 25th year, the 25-year requirement is satisfied if the manufacture date falls anytime within the month 25 years before the date of trade-in, and by certification by the dealer, as provided in Appendix A to this part, certifications section, that the manufacture date is less than 25 years before the date of trade-in.

(c) *Threshold eligibility requirements that apply to all new vehicles.* The new vehicle must:

(1) Be either purchased or leased for a lease period of not less than 5 years;

(2) Have a manufacturer's suggested retail price of \$45,000 or less.

(d) *Trade-in Vehicle—Disclosure of Scrap Value, Engine Disablement, and Title Marking.* As part of a qualifying transaction under this part, the dealer shall:

(1) During the transaction, disclose to the person purchasing or leasing an eligible new vehicle and trading in an eligible trade-in vehicle, the best estimate of the scrap value of the trade-in vehicle, inform that person that the dealer is authorized to retain \$50 of this amount as payment for its administrative costs of participation in the program, and certify, as provided in Appendix A to this part, certifications section, that it has made such disclosure;

(2) Except as provided in paragraph (e) of this section, store the trade-in vehicle at the dealership or property owned by or under the control of the dealership until its engine is disabled following the procedures set forth in Appendix B to this part, disable the engine of the trade-in vehicle at the dealership or property owned by or under the control of the dealership following the procedures set forth in Appendix B to this part, and certify, as provided in Appendix A to this part, dealer certifications section, that either the engine of the trade-in vehicle has been disabled at the dealership or property owned by or under the control of the dealership, or that the trade-in vehicle will be stored at the dealership or property owned by or under the control of the dealership until the engine is disabled and the engine of the trade-in vehicle will be disabled by the dealer at the dealership or property owned by or under the control of the dealership not more than seven calendar days after the dealer's receipt of payment for the transaction; and

(3) Prior to submitting an application for reimbursement under § 599.302, legibly mark the front and back of the trade-in vehicle's title in prominent letters that do not obscure the owner's name, VIN, or other writing as follows: "Junk Automobile, CARS.gov."

(e) *Dealer transfers prior to July 24, 2009.*

(1) Subject to the provisions of paragraph (e)(2) of this section, if the dealer

§ 599.300

49 CFR Ch. V (10–1–10 Edition)

transferred the vehicle prior to July 24, 2009, the dealer may either:

(i) Locate the vehicle, disable its engine following the procedures set forth in Appendix B to this part, and provide the certification in Appendix A to this part, certifications section, that it has disabled the engine; or

(ii) Obtain a sworn affidavit from a disposal facility that it has crushed or shredded the vehicle, including the engine block, and provide supporting documents sufficient to establish that fact.

(2) The dealer and disposal facility must comply with all other requirements of this part, including the requirement that the trade-in vehicle be crushed or shredded, except that the affidavit and supporting documents provided for under paragraph (e)(1)(ii) of this section may substitute for the disposal facility certification form.

(f) *Qualifying transactions (\$3,500 Credit)*. Subject to the requirements of paragraphs (b), (c), and (d), and, if applicable, paragraph (e) of this section and the additional requirements of §§ 599.301, 599.302, and 599.303 of this subpart, each of the following transactions qualifies for a credit of \$3,500 under this program:

(1) The new vehicle is a passenger automobile with a combined fuel economy of at least 22 mpg, the eligible trade-in vehicle has a combined fuel economy of 18 mpg or less and is a passenger automobile, category 1 truck, or category 2 truck, and the combined fuel economy of the new vehicle is at least 4 mpg, but less than 10 mpg higher than the combined fuel economy of the eligible trade-in vehicle.

(2) The new vehicle is a category 1 truck with a combined fuel economy of at least 18 mpg, the eligible trade-in vehicle has a combined fuel economy of 18 mpg or less and is a passenger automobile, category 1 truck, or category 2 truck, and the combined fuel economy of the new vehicle is at least 2 mpg, but less than 5 mpg higher than the combined fuel economy of the eligible trade-in vehicle.

(3) The new vehicle is a category 2 truck with a combined fuel economy of at least 15 mpg, the eligible trade-in vehicle has a combined fuel economy of 18 mpg or less and is a category 2

truck, and the combined fuel economy of the new vehicle is 1 mpg higher than the combined fuel economy of the eligible trade-in vehicle.

(4) The new vehicle is a category 2 truck with a combined fuel economy of at least 15 mpg and the eligible trade-in vehicle is a category 3 truck of model year 2001 or earlier.

(5) The new vehicle is a category 3 truck, the eligible trade-in vehicle is a category 3 truck of model year 2001 or earlier, and the new fuel efficient vehicle has a GVWR less than or equal to the GVWR of the eligible trade-in vehicle.

(g) *Qualifying transactions (\$4,500 Credit)*. Subject to the requirements of paragraphs (b), (c), and (d), and, if applicable, paragraph (e) of this section and the additional requirements of §§ 599.301, 599.302, and 599.303 of this subpart, each of the following transactions qualifies for a credit of \$4,500 under this program:

(1) The new vehicle is a passenger automobile with a combined fuel economy of at least 22 mpg, the eligible trade-in vehicle has a combined fuel economy of 18 mpg or less and is a passenger automobile, category 1 truck, or category 2 truck, and the combined fuel economy of the new vehicle is at least 10 mpg higher than the combined fuel economy of the eligible trade-in vehicle.

(2) The new vehicle is a category 1 truck with a combined fuel economy of at least 18 mpg, the eligible trade-in vehicle has a combined fuel economy of 18 mpg or less and is a passenger automobile, category 1 truck, or category 2 truck, and the combined fuel economy of the new vehicle is at least 5 mpg higher than the combined fuel economy of the eligible trade-in vehicle.

(3) The new vehicle is a category 2 truck with a combined fuel economy of at least 15 mpg, the eligible trade-in vehicle has a combined fuel economy of 18 mpg or less and is a category 2 truck, and the combined fuel economy of the new vehicle is at least 2 mpg higher than the combined fuel economy of the eligible trade-in vehicle.

(h) *No other qualifying transactions*. Transactions described under paragraphs (f) and (g) of this section are the

only transactions that qualify for payment of a credit to a dealer under the CARS Program.

[74 FR 37897, July 29, 2009, as amended at 74 FR 38976, Aug. 5, 2009]

§ 599.301 Limitations and restrictions on qualifying transactions.

(a) *Date of transaction.* A qualifying transaction may not occur on a date before July 1, 2009 or after November 1, 2009, and is subject to available agency funds for the CARS Program.

(b) *One credit per transaction.* Only one credit may be applied towards the purchase or lease price of each new vehicle.

(c) *One credit per person.* A person that participates in a transaction for which a credit is issued under the CARS Program, whether as a single owner or a joint-registered owner of either an eligible trade-in vehicle, a new vehicle, or both, may not participate or be named in another transaction for which a credit is issued under the CARS program, either as a registered owner of the trade-in vehicle or as a purchaser of the new vehicle.

(d) *Transfer of title.*

(1) Except as provided in paragraph (d)(2) of this section, a dealer may not apply for or receive reimbursement for a credit extended to a purchaser under a CARS program transaction unless it has been conveyed clear title and physically possesses the title to the trade-in vehicle.

(2) In the case of a trade-in vehicle registered in a State that is a non-titling jurisdiction and that, in accordance with State law, has no title, the requirement in paragraph (d)(1) of this section that clear title be conveyed is satisfied if the purchaser shows proof of registration in the purchaser's name and provides a bill of sale conferring ownership of the trade-in vehicle to the dealer.

§ 599.302 Dealer application for reimbursement—submission, contents.

(a) *In general.* A dealer's application for reimbursement must demonstrate that the requirements and limitations governing qualifying transactions in § 599.300 and § 599.301 of this subpart have been met, and must comply with

the submission and contents requirements of this section.

(b) *Electronic submission.* The application for reimbursement must be submitted by using the login and password provided under § 599.200(d)(1) and following the procedures provided in the letter mailed under § 599.200(c)(1) of this part.

(c) *Application contents.* An application shall consist of an electronic transaction form (portion reproduced in Appendix C to this part) requiring input of information into relevant fields, electronic copies of supporting documents, and applicable certifications, as provided in Appendix A to this part, certifications section. As its application for each transaction, the dealer shall:

(1) Input the following information into relevant fields on the transaction form:

(i) *Purchaser information.*

(A) *Name.* The first name, middle initial and last name of each purchaser, if an individual, or the full legal name of the company, association or other organization that is the purchaser.

(B) *Residence address (or, for an organization, business address).* The full address of each purchaser.

(C) *Driver's license or State identification number.* The State driver's license or State identification number of each purchaser or, for an organization, its tax identification number.

(ii) *Trade-in vehicle information.*

(A) *Make.* The make of the vehicle.

(B) *Model.* The model of the vehicle.

(C) *Model year.* The model year of the vehicle.

(D) *Vehicle identification number (VIN).* The 17 digit VIN of the vehicle.

(E) *CARS Act vehicle category.* The category of vehicle as defined under the CARS Act. (Enter, as applicable, passenger automobile, category 1 truck, category 2 truck or category 3 truck.)

(F) *State of title.*

(G) *State of registration.*

(H) *Start date of registration.*

(I) *Start date of insurance.*

(J) *End date of registration.*

(K) *Odometer reading.* The odometer reading of the vehicle at the time of the trade-in.

§ 599.303

49 CFR Ch. V (10–1–10 Edition)

(L) *EPA combined fuel economy.* The listed EPA combined fuel economy of the vehicle.

(M) *Vehicle description.* The exact “vehicle description” for the vehicle found on <http://www.fueleconomy.gov>.

(iii) *New vehicle information.*

(A) *Make.* The make of the vehicle.

(B) *Model.* The model of the vehicle.

(C) *Model year.* The model year of the vehicle.

(D) *Vehicle identification number (VIN).* The 17 digit VIN of the vehicle.

(E) *EPA combined fuel economy.* The listed EPA combined fuel economy of the vehicle.

(F) *CARS Act vehicle category.* The category of vehicle as defined under the CARS Act. (Enter, as applicable, passenger automobile, category 1 truck, category 2 truck or category 3 truck.)

(G) *Base manufacturer’s suggested retail price (MSRP).* The price of the new vehicle affixed to the Monroney label prior to the addition of any options, features, taxes or destination charges.

(H) *Vehicle description.* The exact “vehicle description” for the vehicle found on <http://www.fueleconomy.gov>.

(iv) *Trade-in vehicle disposition information.*

(A) *Identification of entity.* The name, address and telephone number of the disposal facility or salvage auction to which the vehicle will be or has been transferred or consigned.

(B) *Disposal facility number.* The unique identifier assigned to the disposal facility identified on the CARS Web site, and to which the vehicle is being transferred or consigned.

(v) *Transaction information.*

(A) *Date of sale or lease.* The date on which the vehicle transaction with the purchaser occurred.

(B) *Transaction request amount.* The amount of the credit for which the dealer is applying.

(2) Attach the following supporting documentation in electronic format (pdf, tif, jpeg) in the following order:

(i) *Proof of title.* A copy of the front and back of the title of the trade-in vehicle, showing assignment to the dealer free and clear of any lien or encumbrance on the vehicle’s title, with the “Junk Automobile, CARS.gov” marking on both sides.

(ii) *Proof of insurance.* A copy of insurance policy cards or documents for the trade-in vehicle to confirm that the trade-in vehicle insurance was continuous for a period of not less than one year prior to trade in.

(iii) *Proof of registration.* A copy of the registration card or documents for the trade-in vehicle identifying the owner, the vehicle, and dates of registration to confirm that the vehicle was registered to the purchaser for a period of not less than one year prior to trade in.

(iv) *Purchaser identification.*

(v) *Summary of sale/lease and certifications form* (Appendix A to this part, summary section).

(vi) *Manufacturer certificate of origin or manufacturer statement of origin of the new vehicle.*

(vii) *CARS purchaser survey.*

(viii) *Fueleconomy.gov side-by-side comparison of the trade-in vehicle and the new vehicle.*

(ix) *Certification from salvage auction or disposal facility.*

(x) *Copy of vehicle sales or lease contract.*

(3) Make the certifications provided in Appendix A to this part, certifications section.

§ 599.303 Agency disposition of dealer application for reimbursement.

(a) *Application review.* Upon receipt of an application for reimbursement, the agency shall review the application to determine whether it is complete and satisfies all the requirements of this subpart.

(b) *Complying application.* An application that is determined to meet all the requirements of this subpart shall be approved for payment, in accordance with the provisions of § 599.304.

(c) *Non-complying application.* An application that is incomplete or that otherwise fails to meet all the requirements of this subpart shall be rejected, and the submitter shall be informed electronically of the reason for rejection. NHTSA shall have no obligation to correct a non-conforming submission.

(d) *Electronic rejection.* An application is automatically rejected, with system notification to the tendering dealer, if

the transaction falls outside of the permissible time period, exceeds the permissible MSRP, identifies a purchaser that has participated in a previous transaction, or identifies the vehicle identification number of a new or trade-in vehicle that was involved in a previous transaction.

(e) *Correction and resubmission.* A dealer may correct and resubmit a rejected application for reimbursement, without penalty.

§ 599.304 Payment to dealer.

Upon completion of review of an application for reimbursement from a registered dealer that satisfies all the requirements of this part, the agency shall reimburse the dealer, by electronic transfer to the account identified under the process in § 599.200(c) of this part.

Subpart D—Disposal of Trade-in Vehicle

§ 599.400 Transfer or consignment by dealer of trade-in vehicle.

(a) *In general.*

(1) A trade-in vehicle accepted as part of an eligible transaction may be provided for disposal by a dealer either to a disposal facility or to a salvage auction, as described in and subject to the conditions of § 599.201 of this part.

(2) Dealers, disposal facilities, and salvage auctions involved in the disposal of the trade-in vehicle must each comply with the applicable provisions of this subpart.

(b) *Transfer by dealer or salvage auction to a disposal facility.* If the trade-in vehicle is transferred by the dealer or salvage auction to a disposal facility, the disposal facility must, as a condition of the transfer:

(1) Make the certifications contained in the Disposal Facility Certification Form in Appendix E to this part, signed by an official with authority to bind the disposal facility;

(2) At the time of the transfer, deliver the signed Disposal Facility Certification Form to the dealer or salvage auction that transferred the trade-in vehicle; and

(3) Comply with the requirements and limitations of § 599.401.

(c) *Consignment by dealer to a salvage auction.* If the trade-in vehicle is consigned by the dealer to a salvage auction, the salvage auction must, as a condition of the consignment:

(1) Make the certifications contained in the Salvage Auction Certification Form in Appendix F to this part, signed by an official with authority to bind the salvage auction;

(2) At the time of the consignment, deliver the signed Salvage Auction Certification Form to the dealer that authorized the salvage auction to sell the trade-in vehicle.

(1) Make the certifications contained in the Salvage Auction Certification Form to the dealer that authorized the salvage auction to sell the trade-in vehicle; and

(3) Comply with the requirements and limitations of § 599.402.

EDITORIAL NOTE: At 74 FR 37902, July 29, 2009, § 599.400 was added, however, there was a codification error in the original document resulting in two paragraphs (c)(1).

§ 599.401 Requirements and limitations for disposal facilities that receive trade-in vehicles under the CARS program.

(a) The disposal facility must:

(1) Not more than 7 days after receiving the vehicle, report the vehicle to NMVTIS as a scrap vehicle.

(2) Remove and dispose of all refrigerants, antifreeze, lead products, mercury switches, and such other toxic or hazardous vehicle components prior to crushing or shredding in accordance with applicable Federal and State requirements;

(3) Crush or shred the trade-in vehicle onsite, including the engine block and the drive train (unless with respect to the drive train, the transmission, drive shaft, and rear end are sold separately), using its own machinery or a mobile crusher, within 270 days after receipt of the vehicle from the dealer or salvage auction;

(4) Not more than 7 days after the vehicle is crushed or shredded, report the vehicle to NMVTIS as crushed or shredded.

(b) The disposal facility may not sell or transfer the engine block of the vehicle or, except as allowed under paragraph (c)(2) of this section, the drive

§ 599.402

train before they are crushed or shredded or otherwise allow the vehicle to leave the disposal facility before it is crushed or shredded.

(c) The disposal facility may:

(1) Sell any part of the vehicle other than the engine block or drive train;

(2) Notwithstanding paragraph (c)(1) of this section, sell the drive train provided the transmission, drive shaft, and rear end are sold as separate parts;

(3) Retain the proceeds from parts sold under this paragraph.

(d) A completed Disposal Facility Certification Form (Appendix E to this part) for an individual transaction, which includes a certification by the disposal facility that the trade-in vehicle will be crushed or shredded within 180 days of receipt by the disposal facility, is deemed to be amended to include an extension of time such that the trade-in vehicle will be crushed or shredded within 270 days of receipt by the disposal facility.

[74 FR 37897, July 29, 2009, as amended at 75 FR 5251, Feb. 2, 2010]

§ 599.402 Requirements and limitations for salvage auctions that are consigned trade-in vehicles under the CARS program.

(a) The salvage auction must:

(1) Within 3 days after the date the dealer consigns the vehicle or prior to auctioning the vehicle, whichever is earlier, report the status of the vehicle to NMVTIS;

(2) Limit participation in the auction to disposal facilities that, when the auction is held:

(i) Appear on the list identified in § 599.201(a)(2) or are described in § 599.201(a)(3); and

(ii) Agree to make the certifications in the Salvage Auction Certification Form (Appendix F to this part).

(3) As a condition of transferring title to the disposal facility, obtain from that facility the signed Disposal Facility Certification Form (Appendix E to this part), insert on the top of the form the appropriate CARS invoice number received from the dealer, if known, and provide the form to NHTSA at *disposal@cars.gov*, and include that invoice number in the e-mail subject line.

(b) [Reserved]

49 CFR Ch. V (10–1–10 Edition)

§ 599.403 Requirements and limitations for dealers.

A dealer receiving a Disposal Facility Certification Form or Salvage Auction Certification Form under § 599.400(b)(2) or (c)(2) shall insert on the top of the form the appropriate CARS invoice number, if known, and within 7 days of receipt, submit such certification form to NHTSA at *disposal@cars.gov*.

Subpart E—Enforcement

§ 599.500 Definitions.

As used in this subpart—

Administrator means the Administrator of the National Highway Traffic Safety Administration, or his or her designee.

Chief Counsel means the NHTSA Chief Counsel, or his or her designee.

Hearing Officer means a NHTSA employee who has been delegated the authority to assess civil penalties.

NHTSA Enforcement means the NHTSA Associate Administrator for Enforcement, or his or her designee.

Notice of violation means a notification of violation and preliminary assessment of penalty issued by the Chief Counsel to a party.

Party means the person alleged to have committed a violation of the CARS Act, regulations thereunder, or other applicable law, and includes an individual, a public or private corporation, and a partnership or other association.

Violation means any non-conformance with the CARS Act or the regulations in this part except § 599.200(e)(1)(i) and § 599.201(c)(1), the submission of incomplete or inaccurate information to NHTSA or an entity identified under this part, or the failure to maintain records, to permit access to records or to update information that has been submitted to NHTSA under this part, but does not include a clerical error. In the context of dealer registration and disposal facility or salvage auction participation eligibility, *violation* also includes any conviction of a crime involving motor vehicles or any fraud or financial crime under State or Federal law.

§ 599.501 Generally.

The provisions of 5 U.S.C. 554, 556 and 557 do not apply to any proceedings conducted pursuant to this subpart.

§ 599.502 Record retention.

(a) Manufacturers, dealers, salvage auctions, and disposal facilities shall keep records of all transactions under the CARS Act and regulations thereunder for a period of five calendar years from the date on which they were generated or acquired by the manufacturer, salvage auction, dealer, or disposal facility, and shall promptly make those records available to NHTSA Enforcement or DOT's Office of the Inspector General upon request.

(b) Records to be retained under this subpart include all documentary materials and other information-storing media that contain information concerning transactions under the CARS Program, including any material generated or communicated by computer, electronic mail, or other electronic means. Such records include, but are not limited to, lists, compilations, certifications, dealer application information, salvage auction or disposal facility information, owner eligibility information, vehicle eligibility information (including vehicle fuel economy), dealer applications for reimbursement under the program, vehicle identification number data, vehicle ownership information, vehicle title, registration and insurance information, sales agreements, bills of sale, lease agreements, manufacturer's certificate or statement of origin, other rebate and/or incentive programs used in conjunction with transactions under the program, bank account and routing number information, electronic funds transfer and payment information, reports made to the National Motor Vehicle Title Information System (NMVTIS), reports regarding vehicle scrappage values and payment, reports in connection with the transfer of vehicles to salvage auctions and disposal facilities; reports from disposal facilities in connection with the crushing or shredding of vehicles under the program, and any other documents that are related to transactions.

(c) Duplicate copies need not be retained. Information may be reproduced

or transferred from one storage medium to another (*e.g.*, from electronic format to CD-ROM) as long as no information is lost in the reproduction or transfer, and when so reproduced or transferred the original form may be treated as a duplicate.

§ 599.503 Access to records.

The Administrator shall have the right to enter onto the premises of manufacturers, dealers, salvage auctions and disposal facilities during normal business hours in order to: access, inspect and audit records and other sources of information maintained by any of these entities under this Program; to inspect vehicles traded in or sold under this program, including taking all actions necessary to determine whether trade-in vehicles have operative engines; and/or to interview persons who may have relevant knowledge.

§ 599.504 Suspension, revocation, and reinstatement of registration and participation eligibility.

(a) *Suspension or revocation of dealer registration, or salvage auction or disposal facility participation eligibility.*

(1) When the NHTSA Chief Counsel determines that a violation has likely occurred, the Administrator may notify the dealer, salvage auction or disposal facility in writing of the facts giving rise to the allegation of a violation and the proposed length of a suspension, if applicable, or revocation of registration, in the case of a dealer, or participation eligibility in the case of a salvage auction or disposal facility.

(2) The notice shall afford the dealer, salvage auction or disposal facility an opportunity to present data, views, and arguments, in writing and/or in person, within 30 days of the date of the notice, as to whether the violation occurred, why its registration or participation eligibility ought not to be suspended or revoked, or whether the suspension should be shorter than proposed. The Administrator may, for good cause, reduce the time allowed for response.

(3) If the Administrator decides, on the basis of the available information, that the dealer, salvage auction or disposal facility has committed a violation, the Administrator may suspend

§ 599.505

49 CFR Ch. V (10–1–10 Edition)

or revoke the dealer registration or the participation eligibility of the salvage auction or disposal facility.

(4) The Administrator shall notify the dealer, salvage auction or disposal facility in writing of the decision, including the reasons for it. The decision shall reflect the gravity of the offense.

(5) A suspension or revocation is effective as of the date of the Administrator's written notification, unless another date is specified therein.

(6) The Administrator shall state the period of any suspension in the notice to the dealer, salvage auction or disposal facility.

(7) There shall be no opportunity to seek reconsideration of the Administrator's decision issued under this paragraph (a).

(b) *Reinstatement of suspended registration or participation eligibility.*

(1) When a registration or participation eligibility has been suspended under this subpart, the registration or participation eligibility will be reinstated after the expiration of the period of suspension specified by the Administrator, or such earlier date as the Administrator may subsequently decide is appropriate.

(2) Reinstatement is automatically effective as of the date previously set forth in the Administrator's written notification of suspension, unless another date is specified by the Administrator in writing.

(c) *Effect of suspension or revocation of registration or participation eligibility.*

(1) If a dealer's registration or a salvage auction or disposal facility's participation eligibility is suspended or revoked, as of the date of suspension or revocation, the dealer, salvage auction or disposal facility will not be considered registered or eligible to participate in the CARS Program, and must cease participating in the program.

(2) A dealer whose registration has been suspended will not be entitled to any rights or reimbursement of funds for new transactions submitted as of the effective date of the suspension or revocation.

(3) NHTSA may take such action as appropriate, including publication, to provide notice that a dealer's registration, or salvage auction's or disposal

facility's participation eligibility has been suspended or revoked.

§ 599.505 Reports and investigations.

(a) Any person may report an apparent violation of the CARS Act or regulations issued thereunder to NHTSA.

(b) NHTSA may independently monitor for violations of the CARS Act or regulations issued thereunder.

(c) When a report of an apparent violation has been received by NHTSA, or when an apparent violation has been detected by any person working for NHTSA, the matter may be investigated or evaluated by NHTSA Enforcement. If NHTSA Enforcement believes that a violation may have occurred, NHTSA Enforcement may prepare a report and send the report to the NHTSA Chief Counsel.

(d) The NHTSA Chief Counsel will review the reports prepared by NHTSA Enforcement to determine if there is sufficient information to establish a likely violation.

(1) The matter may be returned to NHTSA Enforcement for further investigation, if warranted.

(2) The Chief Counsel may close a matter. A matter may be closed if, for example, the investigation has established that a violation did not occur, the alleged violator is unknown, there is insufficient information to support the existence of a violation and little likelihood of discovering additional relevant facts, or the magnitude of the matter is, under the circumstances, including availability of resources, insufficient to be pursued further.

(3) If the Chief Counsel determines that a violation has likely occurred, the Chief Counsel may:

(i) Issue a Notice of Violation to the party, and/or

(ii) In the case of a dealer recommend that the Administrator suspend or revoke registration in the program or in the case of a salvage auction or disposal facility, recommend that the Administrator suspend or revoke participation eligibility in the program.

(4) In the case of either paragraphs (d)(3)(i) or (ii) of this section, the NHTSA Chief Counsel will prepare a case file with recommended actions. A record of any prior violations by the

same person or entity, shall be forwarded with the case file.

§ 599.506 Notice of Violation.

(a) The agency has the authority to assess a civil penalty for any violation of the CARS Act or this part. The penalty may not be more than \$15,000 for each violation.

(b) The Chief Counsel may issue a Notice of Violation to a party. Notice of Violation will contain the following information:

(1) The name and address of the party;

(2) The alleged violation and the applicable law or regulations violated;

(3) The amount of the maximum penalty that may be assessed for each violation;

(4) The amount of proposed penalty;

(5) A statement that payment of the proposed penalty within 30 days will settle the case without admission of liability;

(6) The place to which, and the manner in which, payment is to be made;

(7) A statement that the party may decline the Notice of Violation and that if the Notice of Violation is declined, the party has the right to a hearing prior to a final assessment of a penalty by a Hearing Officer.

(8) A statement that failure to either pay the proposed penalty on the Notice of Violation or to decline the Notice of Violation and request a hearing within 30 days of the date shown on the Notice of Violation will result in a finding of violation by default and that NHTSA will proceed with the civil penalty in the amount proposed on the Notice of Violation without processing the violation under the hearing procedures set forth in this subpart.

(c) The Notice of Violation may be delivered to the party by:

(1) Hand-delivery to the party or an employee of the party;

(2) Mailing to the party (certified mail is not required);

(3) Use of an overnight or express courier service; or

(4) Facsimile transmission or electronic mail (with or without attachments) to the party or an employee of the party.

(d) If a party submits a written request for a hearing as provided in the

Notice of Violation within 30 days of the date shown on the Notice of Violation, the case file will be sent to the Hearing Officer for processing under the hearing procedures set forth in this subpart.

(e) If a party pays the proposed penalty on the Notice of Violation or an amount agreed on in compromise within 30 days of the date shown on the Notice of Violation, a finding of "resolved with payment" will be entered into the case file. Such payment shall not be an admission of liability.

(f) If the party agrees to pay the proposed penalty, but has not made payment within 30 days of the date shown on the Notice of Violation, NHTSA will enter a finding of violation by default in the matter and NHTSA will proceed with the civil penalty in the amount proposed on the Notice of Violation without processing the violation under the hearing procedures set forth in this subpart.

(g) If within 30 days of the date shown on the Notice of Violation a party fails to pay the proposed penalty on the Notice of Violation; and fails to request a hearing, then NHTSA will enter a finding of violation by default in the case file, and will assess the civil penalty in the amount set forth on the Notice of Violation without processing the violation under the hearing procedures set forth in this subpart.

(h) NHTSA's order assessing the civil penalty following a party's default is final agency action.

§ 599.507 Disclosure of evidence.

The alleged violator may, upon request, receive a free copy of all the written evidence in the case file, except material that would disclose or could lead to the disclosure of the identity of a confidential source. Following a timely request for a hearing, other evidence or material, if any, of whatever source or nature, may be examined at the Hearing Officer's offices or such other places and locations that the Hearing Officer may, in writing, direct, if there are adequate safeguards to prevent loss or tampering.

§ 599.508

§ 599.508 Statements of matters in dispute and submission of supporting information.

(a) Within 30 days of the date shown on the Notice of Violation, the party, or counsel for the party, shall submit to NHTSA at the person or office listed in the Notice of Violation two complete copies via hand delivery, use of an overnight or express courier service, facsimile or electronic mail of:

(1) A detailed statement of factual and legal issues in dispute; and,

(2) All statements and documents supporting the party's case.

(b) One copy of the party's submission set forth above shall be labeled "For Hearing Officer."

(c) Failure to specify any non-jurisdictional issue in the party's submission will preclude its consideration.

§ 599.509 Hearing Officer.

(a) If a party timely requests a hearing after receiving a Notice of Violation, the Hearing Officer shall hear the case.

(b) The Hearing Officer is solely responsible for the case referred to him or her. The Hearing Officer has no other responsibility, direct or supervisory, for the investigation of cases referred for the assessment of civil penalties.

(c) The Hearing Officer decides each case on the basis of the information before him or her, and must have no prior connection with the case.

§ 599.510 Initiation of action before the Hearing Officer.

(a) After the Hearing Officer receives a case file from the Chief Counsel, the Hearing Officer notifies the party in writing of:

(1) The date, time and location of the hearing and whether the hearing will be conducted telephonically or at the DOT Headquarters building in Washington, D.C.;

(2) The right to be represented at all stages of the proceeding by counsel as set forth in § 599.511; and,

(3) The right to a free copy of all written evidence in the case file as set forth in § 599.507.

(b) On the request of a party, or at the Hearing Officer's direction, multiple proceedings may be consolidated

49 CFR Ch. V (10-1-10 Edition)

if at any time it appears that such consolidation is necessary or desirable.

§ 599.511 Counsel.

A party has the right to be represented at all stages of the proceeding by counsel. A party electing to be represented by counsel must notify the Hearing Officer of this election in writing, after which point the Hearing Officer will direct all further communications to that counsel. A party represented by counsel bears all of its own attorneys' fees and costs.

§ 599.512 Hearing location and costs.

(a) Unless the party requests a hearing at which the party appears before the Hearing Officer in Washington, DC, the hearing shall be held telephonically. The hearing is held at the headquarters of the U.S. Department of Transportation in Washington, DC.

(b) The Hearing Officer may transfer a case to another Hearing Officer at a party's request or at the Hearing Officer's direction.

(c) A party is responsible for all fees and costs (including attorneys' fees and costs, and costs that may be associated with travel or accommodations) associated with attending a hearing.

§ 599.513 Hearing procedures.

(a) There is no right to discovery in any proceedings conducted pursuant to this subpart.

(b) The material in the case file pertinent to the issues to be determined by the Hearing Officer is presented by the Chief Counsel or his or her designee.

(c) The Chief Counsel may supplement the case file with information prior to the hearing. A copy of such information will be provided to the party no later than 3 days before the hearing.

(d) At the close of the Chief Counsel's presentation of evidence, the party has the right to examine, respond to and rebut material in the case file and other information presented by the Chief Counsel.

(e) In receiving evidence, the Hearing Officer is not bound by strict rules of evidence. In evaluating the evidence presented, the Hearing Officer must

give due consideration to the reliability and relevance of each item of evidence.

(f) A party may present the testimony of any witness either through a written statement or a personal appearance. If a party wishes to present testimony through a personal appearance, the party is responsible for obtaining that personal appearance, including any costs associated with such appearance. The Hearing Officer may, at his or her discretion, accept a stipulation in lieu of testimony.

(g) At the close of the party's presentation of evidence, the Hearing Officer may allow the introduction of rebuttal evidence that may be presented by the Chief Counsel. The Hearing Officer may allow the party to respond to any such evidence submitted.

(h) The Hearing Officer may take notice of matters which are subject to a high degree of indisputability and are commonly known in the community or are ascertainable from readily available sources of known accuracy. Prior to taking notice of a matter, the Hearing Officer shall give the party an opportunity to show why notice should not be taken. In any case in which notice is taken, the Hearing Officer places a written statement of the matters as to which notice was taken in the record, with the basis for such notice, including a statement that the party consented to notice being taken or a summary of the party's objections.

(i) After the evidence in the case has been presented, the Chief Counsel and the party may present argument on the issues in the case. The party may also request an opportunity to submit a written statement for consideration by the Hearing Officer and for further review. If granted, the Hearing Officer shall allow a reasonable time for submission of the statement and shall specify the date by which it must be received. If the statement is not received within the time prescribed, or within the limits of any extension of time granted by the Hearing Officer, the Hearing Officer prepares the decision in the case.

(j) A verbatim transcript of the hearing will not normally be prepared. A party may, solely at its own expense, cause a verbatim transcript to be

made. If a verbatim transcript is made, the party shall submit two copies to the Hearing Officer not later than 15 days of the hearing. The Hearing Officer shall include such transcript in the record.

§ 599.514 Assessment of civil penalties.

(a) Not later than 30 days following the close of the hearing, the Hearing Officer shall issue a written decision on the Notice of Violation, based on the hearing record. The decision shall set forth the basis for the Hearing Officer's assessment of a civil penalty, or decision not to assess a civil penalty. In determining the amount of the civil penalty, the severity of the violation and the intent and history of the party committing the violation shall be taken into account. The assessment of a civil penalty by the Hearing Officer shall be set forth in an accompanying final order.

(b) If the Hearing Officer assesses civil penalties in excess of \$100,000.00, the Hearing Officer's decision contains a statement advising the party of the right to an administrative appeal to the Administrator. The party is advised that failure to submit an appeal within the prescribed time will bar its consideration and that failure to appeal on the basis of a particular issue will constitute a waiver of that issue in its appeal before the Administrator.

(c) The filing of a timely and complete appeal to the Administrator of a Hearing Officer's order assessing a civil penalty shall suspend the operation of the Hearing Officer's penalty.

(d) There shall be no administrative appeals of civil penalties of \$100,000.00 or less.

§ 599.515 Appeals of civil penalties in excess of \$100,000.00.

(a) A party may appeal the Hearing Officer's order assessing civil penalties over \$100,000.00 to the Administrator within 21 days of the date of the issuance of the Hearing Officer's order.

(b) The Administrator will affirm the decision of the Hearing Officer unless the Administrator finds that the Hearing Officer's decision was unsupported by the record as a whole.

(c) If the Administrator finds that the decision of the Hearing Officer was

§ 599.516

unsupported, in whole or in part, then the Administrator may:

- (1) Assess or modify a civil penalty;
 - (2) Rescind the Notice of Violation;
- or
- (3) Remand the case back to the Hearing Officer for new or additional proceedings.

(d) In the absence of a remand, the decision of the Administrator in an appeal is a final agency action.

§ 599.516 Collection of assessed or compromised civil penalties.

(a) Payment of a civil penalty, whether assessed or compromised, shall be made by check, postal money order, or electronic transfer of funds, as provided in instructions by the agency. A payment of civil penalties shall not be considered a request for a hearing.

(b) The party must remit payment of any assessed civil penalty to NHTSA within 30 days after receipt of the Hearing Officer's order assessing civil penalties or, in the case of an appeal to the Administrator, within 30 days after receipt of the Administrator's decision on the appeal. Failure to make timely payment may result in the institution of appropriate action under the Federal Claims Collection Act, as amended, the regulations issued thereunder, and other applicable law.

(c) The party must remit payment of any compromised civil penalty to NHTSA on the date and under such terms and conditions as agreed to by the party and NHTSA. Failure to pay a compromised civil penalty to NHTSA on the date and under such terms and conditions as agreed to by the party and NHTSA may either result in the institution of appropriate action under the Federal Claims Collection Act, as amended, the regulations issued thereunder, and other applicable law, or NHTSA entering a finding of violation by default and assessing a civil penalty in the amount proposed in the Notice of Violation without processing the violation under the hearing procedures set forth in this part.

§ 599.517 Other sanctions.

The procedures and penalties described in this subpart are not the only procedures and penalties that may apply to someone who violates the

49 CFR Ch. V (10–1–10 Edition)

CARS Act or submits a false certification required by this rule. Anyone who submits false information on these forms or otherwise violates the CARS Act or this part may not only be subject to the procedures and penalties described in this subpart, but also civil and criminal penalties. Such civil and criminal penalties may include penalties three times any amount falsely claimed to be due from the United States pursuant to the False Claims Act (31 U.S.C. 3729), or imprisonment of up to 5 years and fines of up to \$250,000 (18 U.S.C. 1001). In addition, NHTSA may request that the Attorney General seek appropriate injunctive relief to address violations of the CARS Act or this part.

Subpart F—Requirements and Procedures for Exceptions

SOURCE: 74 FR 49340, Sept. 28, 2009, unless otherwise noted.

§ 599.600 Exceptions—applicability and requirements.

(a) *Applicability.* (1) *Eligible Requesters.* To qualify for an exception under this subpart, a requester must be a dealer registered in accordance with the requirements of § 599.200.

(2) *Filing deadline.* A request for an exception must be postmarked no later than October 13, 2009.

(3) *Availability of funds.* An exception shall be approved under this subpart only if Federal funds are available for payment.

(4) *Exclusion.* No exception may be approved for an application for reimbursement that was successfully submitted to the CARS system.

(b) *Threshold requirements.* Subject to the requirements of § 599.600(a), a registered dealer may submit a request for exception and seek reimbursement of a CARS credit under this subpart if the dealer:

(1) Prior to August 24, 2009, 8 pm EDT, completed a qualifying deal meeting the requirements of § 599.300 and § 599.301;

(2) Took ownership and possession of a trade-in vehicle and transferred ownership and possession of a new vehicle to the purchaser; and

(3) Prior to August 25, 2009, 8 pm EDT, attempted to submit an application for reimbursement meeting the requirements of § 599.302, but was prevented from submitting the application for any of the reasons identified in § 599.600(c).

(c) *Exception cases.* A dealer is eligible for an exception if:

(1) *Password rejection.* The dealer's account password was locked out and not reset by NHTSA;

(2) *Transaction rejection.* The application was rejected at submission because the dealer entered a State identification number, a trade-in vehicle VIN, or a new vehicle VIN that was already entered into the CARS program system, but that State identification number, trade-in vehicle VIN, or new vehicle VIN was never used for a CARS deal; or

(3) *Other hardship.* The dealer experienced any other hardship attributable to NHTSA action or inaction that the Administrator determines in his or her discretion should be redressed, consistent with the purposes of the CARS Act.

§ 599.601 Procedures for requesting exception.

(a) *Submission.* A request for exception must be made in writing and mailed by United States mail to the NHTSA Administrator, 1200 New Jersey Ave SE., Washington, DC 20590.

(b) *Contents.* The request must include paper copies of the following materials:

(1) *Explanation of hardship.* A written explanation of a hardship identified in § 599.600(c) that prevented the dealer from submitting its transaction, and the steps the dealer took to contact the agency and timely resolve the issue;

(2) *Proof of hardship.* Documents evidencing that the dealer was unable to complete and submit an application for reimbursement prior to the deadline because of hardship caused by NHTSA. Documents may include copies of correspondence with the agency;

(3) *Documentation of qualifying transaction.* Paper copies of all supporting attachments required by § 599.302(c)(2) which reveal that a qualifying CARS transaction, including the transfer of ownership and possession of the trade-in vehicle to the dealer and the delivery of ownership and possession of the new vehicle to the purchaser, was made prior to August 24, 2009, 8 p.m. EDT; and

(4) *Certifications.* Paper copies of all certifications provided in Appendix A to this part, signed by both the dealer and the purchaser.

(5) *Evidence of prior notice to NHTSA.* Evidence, if any, that the dealer attempted to contact NHTSA prior to August 25, 2009, 8 p.m. EDT, to request assistance with a problem described in § 599.600(c).

§ 599.603 Disposition of requests for exception.

(a) *In general.* Upon receipt of the request for exception, the agency will review the request to determine whether the exception should be granted and approved for payment.

(b) *Deciding official.* The NHTSA Administrator or his or her designee shall serve as the Deciding Official for all determinations under this subpart.

(c) *Incomplete requests.* A request for exception that fails to include all of the documents required under this subpart may be rejected without further review.

(d) *Denied requests.* If the Deciding Official denies the request, the requester will be informed in writing of the reasons for the denial of the request.

(e) *Granted requests.* If the Deciding Official grants the request, the requester will be notified by electronic mail, at the e-mail address identified in § 599.200(c)(2)(iii), and the requester's application for reimbursement will be processed for payment by the agency as a qualifying transaction in accordance with § 599.304.

(f) *No appeals.* There are no appeals from the Deciding Official's decision.

APPENDIX A TO PART 599—SUMMARY OF SALE/LEASE AND CERTIFICATIONS

OMB No. 2127-0660
Expiration Date: 01/31/2010



Summary of Sale/Lease & Certifications Form



SUMMARY OF SALE OR LEASE

Date of Sale or Lease	
Purchaser Name(s)	
Purchaser Address	
Purchase or Lease (please specify)	
Make	
Model	
Model Year	
New Vehicle VIN	
Trade-In Vehicle VIN	
New Vehicle Base MSRP	
CARS Credit Applied (\$3,500 or \$4,500)	
Dealer's Best Estimate of Trade-In Vehicle Scrappage Value	
Dealer Rebate(s) or Discount(s) (please specify; if none, enter "none.")	
Manufacturer Rebate(s) or Discount(s) (please specify; if none, enter "none.")	
Other available Federal, State, or local incentive(s) or State- issued voucher(s) (please specify; if none, enter "none.")	
Other Rebate(s) or Discount(s) (please specify; if none, enter "none.")	

WARNING

This is a legal document that contains certifications under penalty of law. There are significant civil and criminal penalties for submitting false information. Please read each certification and ensure that the information that you are certifying by signing this document is, to the best of your knowledge and belief, true, accurate, and complete.

DEALER CERTIFICATIONS

The person signing this document as "Dealer" certifies under penalty of law that:

Registration in the CARS Program

- The dealer has been approved as a registered dealer under the CARS program.
- The dealer has a currently active business license under State law to operate a new automobile dealership.
- The dealer has a currently active franchise agreement with an original equipment manufacturer to sell new automobiles.

Summary of Sale or Lease

- The summary of sale or lease set forth above is true and correct.

Purchaser and Trade-In Vehicle Eligibility for the CARS Program

- I have verified the identity of the person signing this document under "Purchaser" (hereinafter simply "Purchaser").
- I have verified that the trade-in vehicle is in drivable condition, and I or an employee under my direction or supervision has operated the trade-in vehicle to confirm that the trade-in vehicle is in drivable condition.
- I have verified that the trade-in vehicle has been continuously insured for a period of not less than one (1) year prior to the date of this transaction (not applicable to trade-in vehicles registered in New Hampshire or Wisconsin).
- I have verified that the Purchaser has been the registered owner of the trade-in vehicle continuously for a period of not less than one (1) year prior to the date of this transaction.
- I have observed the trade-in vehicle's date of manufacture (both month and year) as it appears on the trade-in vehicle's safety standard certification label, and have verified that the trade-in vehicle was manufactured less than 25 years before the date of the trade-in.
- I have verified that the trade-in vehicle's fuel economy is eligible for the CARS program.

New Vehicle Eligibility for the CARS Program

- The new vehicle is being purchased or, in the case of a lease, leased for a period of not less than five (5) years.
- I have verified that the CARS program credit amount requested (i.e., either \$3,500.00 or \$4,500.00, as applicable) corresponds to the difference between the trade-in vehicle's fuel economy and the new vehicle's fuel economy under the requirements of the CARS program.
- The new vehicle has a base manufacturer's suggested retail price (MSRP) as shown on the Monroney label affixed to the new vehicle of \$45,000 or less (exclusive of any accessories, optional equipment, taxes or destination charges).

Transaction Conforms to the Requirements of the CARS Program

- I have reduced the price of the new vehicle that is being purchased or leased by the CARS Program credit amount requested (i.e., either \$3,500.00 or \$4,500.00, as applicable).

- I have disclosed to the Purchaser the best estimate of the scrappage value of the trade-in vehicle.
- I have retained no more than \$50.00 of the scrappage value as payment for any of the dealer's administrative costs in connection with this CARS transaction.
- I have not charged the Purchaser any additional fees for participating in the CARS program in this transaction.
- I have applied the credit under the CARS program in addition to any other rebate or discount advertised by the dealer or offered by the manufacturer for the new vehicle, and have not used the CARS program credit to offset any such other rebate or discount.
- I have not reduced the value of the CARS program credit amount requested (i.e., either \$3,500.00 or \$4,500.00, as applicable) by any other available Federal, State, or local incentive or a State-issued voucher for the purchase or lease of a new fuel efficient automobile.

Disposal of the Trade-in Vehicle

- The trade-in vehicle has not been, and will not be, sold, leased, exchanged or otherwise disposed of for use as an automobile in the United States or in any other country.
- As a condition of the government's payment of the credit to me, (a) I have disabled the engine following the procedures of the CARS Program; or (b) I will store the trade-in vehicle at the dealership or property owned by or under the control of the dealership until the engine is disabled by me, and will disable the engine following the procedures of the CARS Program not more than seven calendar days after receiving payment by the government for the transaction and prior to transferring possession of the trade-in vehicle; or, (c) if this transaction occurred prior to July 24, 2009 and the trade-in vehicle is no longer in my possession, then I have either located the vehicle, disabled the engine following the procedures of the CARS Program and hereby certify that I have done so, or I am submitting to NHTSA under Miscellaneous Documents a sworn affidavit from a disposal facility that the engine block has been crushed or shredded.
- I have transferred or will transfer the trade-in vehicle, including the engine block, to either: (a) a CARS program participating disposal facility that will crush or shred the trade-in vehicle; or, (b) to a participating salvage auction that will transfer the vehicle to such a disposal facility.
- I have provided the disposal facility and/or salvage auction information and written notice that it is responsible for the removal and appropriate disposition of refrigerants, antifreeze, lead products, mercury switches, and such other toxic or hazardous vehicle components prior to the crushing or shredding of an eligible trade-in vehicle, in accordance with all applicable Federal and State requirements.

PURCHASER CERTIFICATIONS

All persons signing this document as "Purchaser" certifies under penalty of law that:

Summary of Sale or Lease

- The summary of sale or lease set forth above is true and correct.

Purchaser and Trade-In Vehicle Eligibility for the CARS Program

- The information I have provided to the dealer verifying my identity is true and correct.
- I have not previously participated in the CARS program.
- The trade-in vehicle is in drivable condition, and an employee of the dealer has operated the trade-in vehicle to confirm that the trade-in vehicle is in drivable condition.

- The trade-in vehicle has been continuously insured for a period of not less than one (1) year prior to the date of this transaction (not applicable to trade-in vehicles registered in New Hampshire or Wisconsin).
- I have been the registered owner of the trade-in vehicle continuously for a period of not less than one (1) year prior to the date of this transaction.
- The trade-in vehicle was manufactured less than 25 years before the date of this transaction.
- The trade-in vehicle's fuel economy is eligible for the CARS program.
- The trade-in vehicle has not been a part of any previous CARS program transaction.

I certify under penalty of law that:

- *I have authority to execute this document,*
- *I have read each of the foregoing certifications,*
- *I understand that payment of the CARS program credit amount is conditioned on compliance with these certifications,*
- *This document, and all attachments, were either prepared by me or prepared under my direction or supervision,*
- *The information set forth in this document, and all attachments, is, to the best of my knowledge and belief, true, accurate, and complete,*
- *I am aware that there are significant penalties for submitting false information, including the possibility of civil penalties under the CARS program, suspension or revocation of continued participation in the CARS program, as well as fines and/or imprisonment.*

DATE: _____, 2009

DEALER

(signature)

(print name)

(title)

(contact phone and e-mail)

DATE: _____, 2009

PURCHASER

(signature)

(print name)

Pt. 599, App. A

49 CFR Ch. V (10-1-10 Edition)

DATE: _____, 2009

PURCHASER (ADDITIONAL) (if any)

(signature)

(print name)

Privacy Act Statement

This notice is provided pursuant to the Privacy Act of 1974, 5 USC § 552a: This information is solicited under the authority of Public Law 111-32, 123 Stat. 1859. Furnishing the information is voluntary, but failure to provide all or part of the information may result in disapproval of your request for a credit on this purchase or lease transaction under the Cars Program. The principal purposes for collecting the information are to determine if purchase or lease transactions are eligible for credits under the CARS Program, to ensure proper disposal of trade-in vehicles, to prevent, identify and penalize fraud in connection with the Program, and to update an existing government database of Vehicle Identification Numbers. If you complete the optional survey, the survey information will be used to report to Congress on the Program. Other routine uses are published in the Federal Register at 65 F.R. 19476 (April 11, 2000), available at: www.dot.gov/privacy.

Paperwork Reduction Act Burden Statement

A federal agency may not conduct or sponsor, and a person is not required to respond to, nor shall a person be subject to a penalty for failure to comply with a collection of information subject to the requirements of the Paperwork Reduction Act unless that collection of information displays a current valid OMB Control Number. The OMB Control Number for this information collection is 2127-0660. Public reporting for this collection of information is estimated to be approximately 17 minutes per response for dealers, 11 minutes for buyers, including the time for reviewing instructions, completing and reviewing the collection of information. All responses to this collection of information are mandatory. Send comments regarding this burden estimate or any other aspect of this collection of information, including suggestions for reducing this burden to: Information Collection Clearance Officer, National Highway Traffic Safety Administration, 1200 New Jersey Ave, S.E., Washington, DC, 20590.

NHTSA Form 1072

[74 FR 38976, Aug. 5, 2009]

APPENDIX B TO PART 599—ENGINE DISABLEMENT PROCEDURES FOR THE CARS PROGRAM

Engine Disablement Procedures for the CARS Program
THIS PROCEDURE IS NOT TO BE USED BY THE VEHICLE OWNER

Perform the following procedure to disable the vehicle engine.

Since the vehicle will not be drivable after this procedure is performed, consider where the procedure will be performed and how the vehicle will be moved after the procedure is complete.

1. Obtain solution of 40% sodium silicate/60% water. (The Sodium Silicate ($\text{SiO}_2/\text{Na}_2\text{O}$) used in the solution must have a weight ratio of 3.0 or greater.)
2. Drain engine oil for environmentally appropriate disposal.
3. Install the oil drain plug.
4. Pour enough solution in the engine through the oil fill for the oil pump to circulate the solution throughout the engine. Start by adding 2 quarts of the solution, which should be sufficient in most cases.
CAUTION: Wear goggles and gloves. Appropriate protective clothing should be worn to prevent silicate solution from coming into contact with the skin.
5. Replace the oil fill cap.
6. Start the engine.
7. Run engine at approximately 2000 rpm (for safety reasons do not operate at high rpm) until the engine stops. (Typically the engine will operate for 3 to 7 minutes. As the solution starts to affect engine operation, the operator will have to apply more throttle to keep the engine at 2000 rpm.)
8. Allow the engine to cool for at least 1 hour.
9. With the battery at full charge or with auxiliary power to provide the power of a fully charged battery, attempt to start the engine.
10. If the engine will not operate at idle, the procedure is complete.
11. If the engine will operate at idle, repeat steps 6 through 10 until the engine will no longer idle.
12. Attach a label to the engine that legibly states the following:

This engine is from a vehicle that is part of the Car Allowance Rebate System (CARS). It has significant internal damage caused by operating the engine with a sodium silicate solution (liquid glass) instead of oil.

APPENDIX C TO PART 599—ELECTRONIC TRANSACTION SCREEN

CARS ISupplier Portal Home Logout Preferences

Home Finance

Create Invoices View Invoices

Details Legal Information Review and Submit

Create Invoice: Details

* Indicates required field
✓ TIP % sign is the wildcard character to search on in any List of Values

Cancel Step 1 of 3 Next

Dealership Information	Invoice
<p>* Name <input type="text"/></p> <p>* Remit To <input type="text"/> <input type="text"/></p> <p>Address <input type="text"/></p> <p>* Remit To Bank Account <input type="text"/></p>	<p>* Invoice Number <input type="text"/></p> <p>✓ TIP Do not enter any special characters eg. \$ & @</p> <p>* Invoice Date <input type="text" value="21-Jul-2009"/> <input type="text"/></p> <p><small>(example: 21-Jul-2009)</small></p> <p>* Currency <input type="text" value="USD"/></p> <p>Invoice Description <input type="text"/></p> <p>* Sale Date <input type="text"/></p> <p>* Disposal Status <input type="text"/></p> <p>* Disposal Facility ID <input type="text"/></p> <p>* Disposal Facility Contact Info <input type="text"/></p> <p>* Purchaser Full Name <input type="text"/></p> <p>* Purchaser Full Address <input type="text"/></p> <p>* Purchaser State ID Number <input type="text"/></p> <p>Co-Owner Purchaser State ID Number <input type="text"/></p> <p>* Sales Type <input type="text"/></p> <p style="text-align: right;">Attachment <input type="text" value="None"/> <input type="button" value="Add"/></p>
* Amount	
<p>✓ TIP Do not enter any special characters. (eg. & % \$) for VIN</p> <p>* Trade-In VIN <input type="text"/></p> <p>* Trade-In Vehicle Category <input type="text"/></p> <p>* Trade-In Vehicle Description <input type="text"/></p> <p>* Trade-In Title State <input type="text"/></p> <p>* Trade-In Registration State <input type="text"/></p> <p>* Trade-In Registration Start Date <input type="text"/></p> <p>* Trade-In Registration Expiration Date <input type="text"/></p> <p>Trade-In Insurance Start Date <input type="text"/></p> <p>Trade-In Flagged Date <input type="text"/></p> <p>* Trade-In Odometer Reading <input type="text"/></p> <p>* New Vehicle VIN <input type="text"/></p> <p>* New Vehicle Category <input type="text"/></p> <p>* New Vehicle Description <input type="text"/></p> <p>* New Vehicle Base MSRP <input type="text"/></p>	

Cancel Step 1 of 3 Next

Privacy Statement
Home Finance Home Logout Preferences

Copyright (c) 2006, Oracle. All rights reserved.

APPENDIX D TO PART 599—CARS PURCHASER SURVEY



**Survey of Consumer Response to
(Commonly known as 'Cash for Clunkers')**



OMB 2127-0659 Exp. 1/31/2009

Please answer the following 3 questions regarding your trade-in transaction. Your answers are for program evaluation purposes only and will not influence your eligibility in any way. Please put an X in the box by the appropriate answer.

Question #1: If you were not offered the CARS program trade-in incentive, would you still have traded in your current vehicle to purchase a new or used vehicle this month?

a) Yes

b) No

If no, when were you planning to trade-in, sell or dispose of your vehicle?

- | | | |
|---|----------------------------------|---|
| <input type="checkbox"/> Within the next year | <input type="checkbox"/> 4 years | <input type="checkbox"/> 8 years |
| <input type="checkbox"/> In about 1 year | <input type="checkbox"/> 5 years | <input type="checkbox"/> 9 years |
| <input type="checkbox"/> 2 years | <input type="checkbox"/> 6 years | <input type="checkbox"/> 10 years |
| <input type="checkbox"/> 3 years | <input type="checkbox"/> 7 years | <input type="checkbox"/> More than 10 years |

Question #2: If you were not offered the CARS program trade-in incentive, when you disposed of this vehicle, would you have purchased another vehicle?

a) No

b) Yes, a new vehicle (Please select one type below)

c) Yes, a used vehicle (Please select one type below)

- a) **a subcompact car** (for example a Honda Fit, or a Toyota Yaris, etc.)
- b) **a compact car** (ex. Ford Focus, Nissan Sentra, Toyota Corolla, Honda Civic, etc.)
- c) **a mid-sized car** (ex. Chevrolet Malibu, Nissan Altima, Toyota Camry, etc.)
- d) **a large car** (ex. Chrysler 300, Ford Crown Victoria, etc.)
- e) **a small SUV** (ex. Honda CR-V, Ford Escape, etc.)
- f) **a mid-sized SUV** (ex. Ford Explorer, Honda Pilot, etc.)
- g) **a large SUV** (ex. Chevrolet Suburban, Ford Expedition, etc.)
- h) **a small pickup** (ex. Ford Ranger, etc.)
- i) **a mid-sized pickup** (ex. Dodge Dakota, Toyota Tacoma, etc.)
- j) **a large pickup** (ex. Chevrolet Silverado, Ford F-150, etc.)
- k) **a full sized passenger van** (ex. Ford E-Series, Chevrolet Express, etc.)
- l) **a full sized cargo van** (ex. Chevrolet Express, Dodge Sprinter, etc.)
- m) **a mini-van** (ex. Toyota Sienna, Dodge Caravan, etc.)
- n) **other type** (specify) _____

Question #3: What is your best estimate of the number of miles you drove the traded-in vehicle during the past 12 months?

- | | | |
|--|--|--|
| <input type="checkbox"/> 0 – 2,499 | <input type="checkbox"/> 7,500 – 9,999 | <input type="checkbox"/> 15,000 – 17,499 |
| <input type="checkbox"/> 2,500 – 4,999 | <input type="checkbox"/> 10,000 – 12,499 | <input type="checkbox"/> 17,500 – 19,999 |
| <input type="checkbox"/> 5,000 – 7,499 | <input type="checkbox"/> 12,500 – 14,999 | <input type="checkbox"/> 20,000 or more |

*Thank you for participating in the CARS Initiative Consumer Response Survey!
Please contact the CARS Hotline at (866)-CAR-7891 or TTY at (800)-424-9153 if you wish to provide any comments.*

APPENDIX E TO PART 599—DISPOSAL FACILITY CERTIFICATION FORM

Appendix E to Part 599 – Disposal Facility Certification Form

OMB No. 2127-0658
Expiration Date: 01/31/2010



Disposal Facility Certification Form



Disposal Facility Information			
CARS Invoice No. (if available)			
NHTSA Disposal Facility Identification No. (if assigned)			
Legal Business Name			
Doing Business As (DBA)/Common Name (if different from Legal Business Name)			
Address (including Street, City, State, ZIP Code)			
Trade-In Vehicle Information			
Make	Model	Model Year	
Trade-In Vehicle VIN		Odometer Mileage	
Dealer or Salvage Auction Transferring Trade-In Vehicle Information			
Legal Business Name			
Doing Business As (DBA)/Common Name (if different from Legal Business Name)			
Address (including Street, City, State, ZIP Code)			
Check one:	Contact Name and Title	Contact Phone and Email	
<input type="checkbox"/> Dealer			
<input type="checkbox"/> Salvage Auction			
Address (including Street, City, State, ZIP Code)	Date this Facility Received the Trade-In Vehicle from Dealer or Salvage Auction		

WARNING

This is a legal document that contains certifications under penalty of law. There are significant civil and criminal penalties for submitting false information. Please read each certification and ensure that the information that you are certifying by

signing this document is, to the best of your knowledge and belief, true, accurate, and complete.

The person signing this document certifies under penalty of law that:

- This facility appears on the CARS program Disposal Facility List.
- This facility participates in the End of Life Vehicle Solutions (ELVS) program. (Excluding facilities located in Maine or a U.S. territory).
- This facility is capable of crushing or shredding the trade-in vehicle, either with its own equipment or by use of a mobile crusher.
- This facility meets all applicable Federal and State laws.
- This facility has a currently active State license to operate as a disposal facility in the State where it is located.
- This facility received the trade-in vehicle bearing the above listed Vehicle Identification Number (VIN) on the date listed above from the dealer or salvage auction listed above.
- I, or an employee of this facility under my direction or supervision, will report to the National Motor Vehicle Title Information System (NMVTIS) the status of the trade-in vehicle as a scrap vehicle not more than seven (7) days after the above-listed date of receipt.
- The trade-in vehicle has not been, and will not be, sold, leased, exchanged or otherwise disposed of for use as an automobile in the United States or in any other country.
- This facility will not transfer the trade-in vehicle to another disposal facility prior to its crushing or shredding.
- This facility will not sell or transfer the trade-in vehicle's engine block and drive train (unless with respect to the drive train, the transmission, drive shaft, or rear end are sold as separate parts) at any time prior to its crushing or shredding.
- I, or an employee of this facility under my direction or supervision, will dispose of refrigerants, antifreeze, lead products, mercury switches, and such other toxic or hazardous vehicle components prior to the crushing or shredding of the trade-in vehicle, in accordance with all applicable Federal and State requirements.
- If this facility participates in ELVS, I, or an employee of this facility under my direction or supervision, will return all mercury switches in accordance with the procedures of the National Vehicle Mercury Switch Recovery Program (NVMSRP).
- I, or an employee of this facility under my direction or supervision, will crush or shred (or cause to be crushed or shredded on our premises), the trade-in vehicle within one-hundred eighty (180) days after the above-listed date of receipt.
- I, or an employee of this facility under my direction or supervision, will report to NMVTIS that this facility crushed or shredded the trade-in vehicle not more than seven (7) days after the date of crushing or shredding. (**Note:** The CARS program does not require that this facility, or any other entity which may subsequently receive the crushed trade-in vehicle, subsequently submit to NHTSA a CARS program Disposal Facility Certification Form, nor does it require that this facility, or any other entity which may subsequently receive the crushed trade-in vehicle, report to NMVTIS that the crushed trade-in vehicle has been shredded).

I certify under penalty of law that:

- ***I have authority to execute this document,***
- ***I have read each of the foregoing certifications,***
- ***This document, and any attachments, were either prepared by me or prepared under my direction or supervision,***
- ***The information set forth in this document, and any attachments, is, to the best of my knowledge and belief, true, accurate, and complete,***

- *I am aware that there are significant penalties for submitting false information, including the possibility of civil penalties under the CARS program, suspension or revocation of continued participation in the CARS program, as well as fines and/or imprisonment.*

DATE: _____, 2009

DISPOSAL FACILITY

(signature)

(print name)

(title)

(contact phone and e-mail)

Privacy Act Statement

This notice is provided pursuant to the Privacy Act of 1974, 5 USC § 552a: This information is solicited under the authority of Public Law 111-32, 123 Stat. 1859. Furnishing the information is voluntary, but failure to provide all or part of the information may result in disapproval of a request for a credit on this purchase or lease transaction under the Cars Program. The principal purposes for collecting the information are to ensure proper disposal of trade-in vehicles, to prevent, identify and penalize fraud in connection with the Program, and to update an existing government database of Vehicle Identification Numbers. Other routine uses are published in the Federal Register at 65 F.R. 19476 (April 11, 2000), available at: www.dot.gov/privacy.

Paperwork Reduction Act Burden Statement

A federal agency may not conduct or sponsor, and a person is not required to respond to, nor shall a person be subject to a penalty for failure to comply with a collection of information subject to the requirements of the Paperwork Reduction Act unless that collection of information displays a current valid OMB Control Number. The OMB Control Number for this information collection is 2127-0658. Public reporting for this collection of information is estimated to be approximately 5 minutes per response, including the time for reviewing instructions, completing and reviewing the collection of information. All responses to this collection of information are mandatory. Send comments regarding this burden estimate or any other aspect of this collection of information, including suggestions for reducing this burden to: Information Collection Clearance Officer, National Highway Traffic Safety Administration, 1200 New Jersey Ave, S.E., Washington, DC, 20590.

NHTSA Form 1073

[74 FR 38976, Aug. 5, 2009]

APPENDIX F TO PART 599—SALVAGE AUCTION CERTIFICATION FORM



Salvage Auction Certification Form

OMB 2127-0658

Exp. 1/31/2009



Salvage Auction Information	
CARS Invoice No. (if available)	
Legal Business Name	
Doing Business As (DBA)/Common Name (if different from Legal Business Name)	
Address (including Street, City, State, ZIP Code)	
Trade-In Vehicle Information	
Make	Model Year
Model	
Trade-In Vehicle VIN	Odometer Mileage
Dealer Transferring Trade-In Vehicle Information	
Legal Business Name	
Doing Business As (DBA)/Common Name (if different from Legal Business Name)	
Address (including Street, City, State, ZIP Code)	
Contact Name and Title	Contact Phone and Email
Address (including Street, City, State, ZIP Code)	Date this Salvage Auction Received the Trade-In Vehicle from Dealer

WARNING

This is a legal document that contains certifications under penalty of law. There are significant civil and criminal penalties for submitting false information. Please read each certification and ensure that the information that you are certifying by signing this document is, to the best of your knowledge and belief, true, accurate, and complete.

APPENDIX F TO PART 599—SALVAGE AUCTION CERTIFICATION FORM

The person signing this document certifies under penalty of law that:

- This facility meets all applicable Federal and State laws.
- This facility has a currently active State license to conduct business as a salvage auction in the State where it is located.
- This facility received the trade-in vehicle bearing the above listed Vehicle Identification Number (VIN) on the date listed above from the dealer listed above.
- I, or an employee of this facility under my direction or supervision, will report to the National Motor Vehicle Title Information System (NMVTIS) the status of the trade-in vehicle within three (3) days after the date the dealer consigns the trade-in vehicle, or prior to auction (whichever is earlier).
- This facility will limit any auction sale of the trade-in vehicle solely to disposal facilities that appear on the CARS program Disposal Facility List.
- The trade-in vehicle has not been, and will not be, sold, leased, exchanged or otherwise disposed of for use as an automobile in the United States or in any other country.
- This facility will not remove any parts from the trade-in vehicle.
- This facility will not transfer the trade-in vehicle at any time prior to its sale at auction, and then only to a disposal facility that appears on the CARS program Disposal Facility List.

I certify under penalty of law that:

- ***I have authority to execute this document,***
- ***I have read each of the foregoing certifications,***
- ***This document, and any attachments, were either prepared by me or prepared under my direction or supervision,***
- ***The information set forth in this document, and any attachments, is, to the best of my knowledge and belief, true, accurate, and complete,***
- ***I am aware that there are significant penalties for submitting false information, including the possibility of civil penalties under the CARS program, suspension or revocation of continued participation in the CARS program, as well as fines and/or imprisonment.***

DATE: _____, 2009

SALVAGE AUCTION

(signature)

(print name)

(title)

(contact phone and e-mail)

Privacy Act Statement

This notice is provided pursuant to the Privacy Act of 1974, 5 USC § 552a: This information is solicited under the authority of Public Law 111-32, 123 Stat. 1859. Furnishing the information is voluntary, but failure to provide all or part of the information may result in disapproval of a request for a credit on this purchase or lease transaction under the Cars Program. The principal purposes for collecting the information are to ensure proper disposal of trade-in vehicles, to prevent, identify and penalize fraud in connection with the Program, and to update an existing government database of Vehicle Identification Numbers. Other routine uses are published in the Federal Register at 65 F.R. 19476 (April 11, 2000), available at: www.dot.gov/privacy.

Paperwork Reduction Act Burden Statement

A federal agency may not conduct or sponsor, and a person is not required to respond to, nor shall a person be subject to a penalty for failure to comply with a collection of information subject to the requirements of the Paperwork Reduction Act unless that collection of information displays a current valid OMB Control Number. The OMB Control Number for this information collection is 2127-0658. Public reporting for this collection of information is estimated to be approximately XX minutes per response, including the time for reviewing instructions, completing and reviewing the collection of information. All responses to this collection of information are mandatory. Send comments regarding this burden estimate or any other aspect of this collection of information, including suggestions for reducing this burden to: Information Collection Clearance Officer, National Highway Traffic Safety Administration, 1200 New Jersey Ave, S.E., Washington, DC, 20590.