



This is a digital copy of a book that was preserved for generations on library shelves before it was carefully scanned by Google as part of a project to make the world's books discoverable online.

It has survived long enough for the copyright to expire and the book to enter the public domain. A public domain book is one that was never subject to copyright or whose legal copyright term has expired. Whether a book is in the public domain may vary country to country. Public domain books are our gateways to the past, representing a wealth of history, culture and knowledge that's often difficult to discover.

Marks, notations and other marginalia present in the original volume will appear in this file - a reminder of this book's long journey from the publisher to a library and finally to you.

### **Usage guidelines**

Google is proud to partner with libraries to digitize public domain materials and make them widely accessible. Public domain books belong to the public and we are merely their custodians. Nevertheless, this work is expensive, so in order to keep providing this resource, we have taken steps to prevent abuse by commercial parties, including placing technical restrictions on automated querying.

We also ask that you:

- + *Make non-commercial use of the files* We designed Google Book Search for use by individuals, and we request that you use these files for personal, non-commercial purposes.
- + *Refrain from automated querying* Do not send automated queries of any sort to Google's system: If you are conducting research on machine translation, optical character recognition or other areas where access to a large amount of text is helpful, please contact us. We encourage the use of public domain materials for these purposes and may be able to help.
- + *Maintain attribution* The Google "watermark" you see on each file is essential for informing people about this project and helping them find additional materials through Google Book Search. Please do not remove it.
- + *Keep it legal* Whatever your use, remember that you are responsible for ensuring that what you are doing is legal. Do not assume that just because we believe a book is in the public domain for users in the United States, that the work is also in the public domain for users in other countries. Whether a book is still in copyright varies from country to country, and we can't offer guidance on whether any specific use of any specific book is allowed. Please do not assume that a book's appearance in Google Book Search means it can be used in any manner anywhere in the world. Copyright infringement liability can be quite severe.

### **About Google Book Search**

Google's mission is to organize the world's information and to make it universally accessible and useful. Google Book Search helps readers discover the world's books while helping authors and publishers reach new audiences. You can search through the full text of this book on the web at <http://books.google.com/>

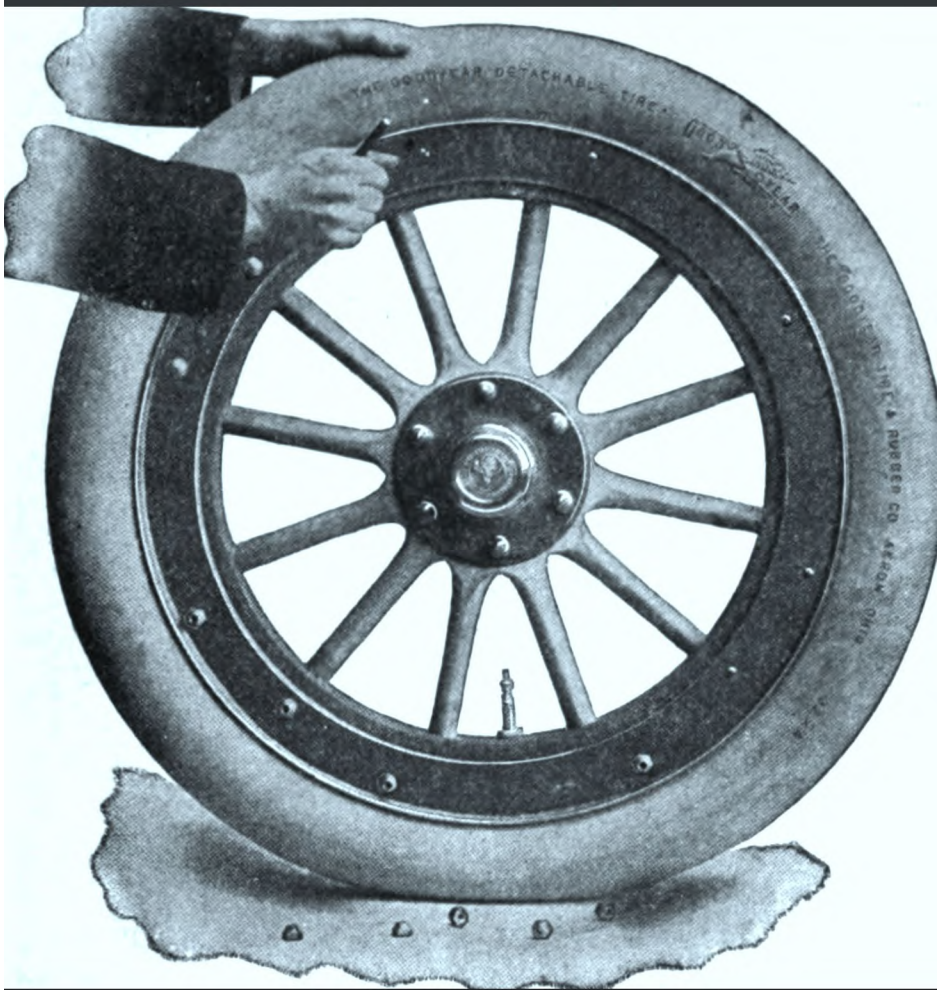

*Diseases of a gasolene  
automobile and how to cure ...*

Andrew Lee Dyke, G. P. Dorris

A

755,357

# DISEASES GASOLINE AVTOMOBILE and HOW TO CVRE THEM



D. ALDINE

PROPERTY OF  
*University of  
Michigan*  
TRANSFORMATION LIBRARY  
*Libraries*

1817

ARTES SCIENTIA VERITAS





# Diseases of a Gasolene Automobile

—AND—

## How to Cure Them.

A Practical Book for the GASOLENE AUTOMOBILE  
OWNER, OPERATOR, REPAIRMAN, INTEND-  
ING PURCHASER and THOSE WISH-  
ING TO LEARN THE FIRST  
PRINCIPILES OF AN  
AUTOMOBILE.

Also for LAUNCH OWNERS and all GASOLENE ENGINE  
OWNERS who have or wish to Equip their  
Engines with the JUMP SPARK SYSTEM,  
including PLANS and DIAGRAMS  
of all ELECTRICAL  
CONNECTIONS.

TRANSPORTATION LIBRARY

BY

A. L. DYKE AND G. P. DORRIS.

**Transportation  
Library**

76  
208  
.D38

**Copyrighted 1903**

**By**

**A. L. DYKE, St. Louis, Mo.**

**Published by**

**A. L. DYKE AUTOMOBILE SUPPLY CO.**

**2108 Olive St., ST. LOUIS, U. S. A.**



DeLiquet  
2-23-32  
Transport.

## Preface.

---

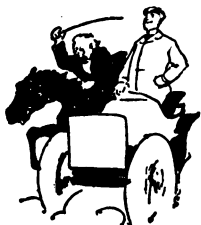

**E**VEN in the annals of applied electricity where phenomenal growth has been a leading characteristic, perhaps nothing has equalled the rapidity with which the automobile has come into actual use.

In the popular mind a great deal of mystery surrounds their workings. The simple book herewith submitted is an attempt to describe the first principles.

No attempt has been made to treat the subject in a theoretical manner, the authors' intention being to adhere strictly, in as brief a manner as possible, to the practical questions concerning the Gasolene Automobile.

I have reason to believe that this book will save many an owner, not only much time and money but will also save him much mental worry and make him and his automobile closer friends.

If it does this, it will have attained its purpose.

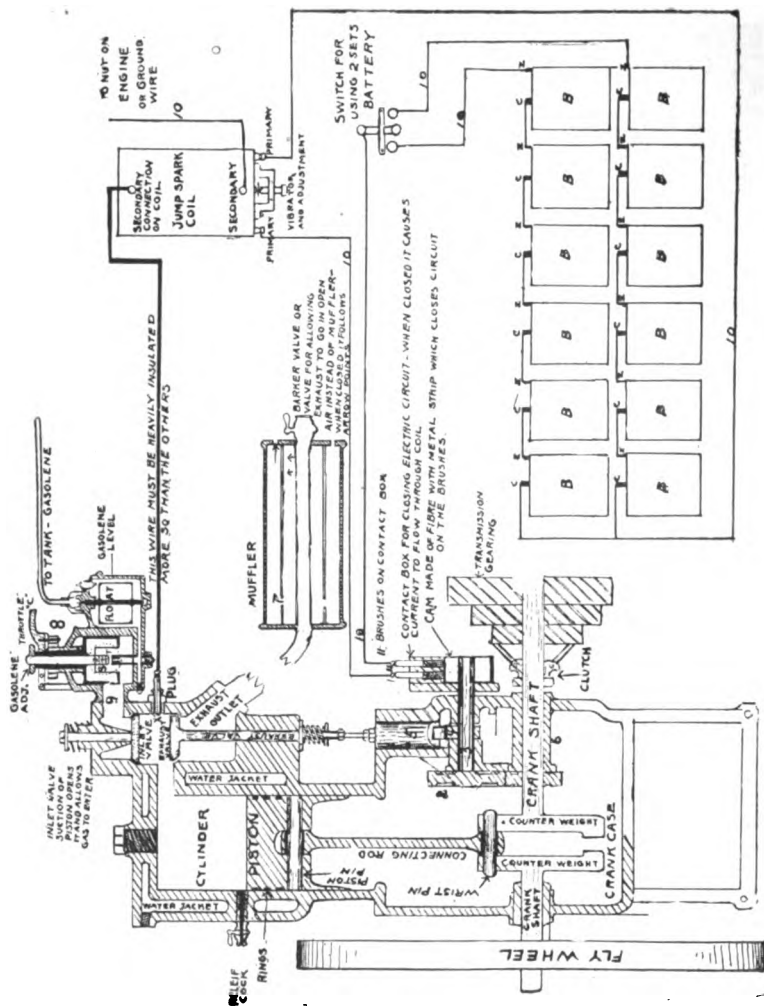

**No. 2.** Large Gear twice the size of Gear below it, object is to cause cam on igniter to run one-half of the speed of engine shaft.

- 3.** Is Shaft of large gear.
- 4.** Is Cam which lifts plunger.
- 5.** Plunger which lifts Exhaust Valve.
- 6.** Gasolene Connection on Carburettor.
- 9.** Gas Inlet.
- 10.** No. 12 Rubber Covered Flexible Stranded Wire.
- 11.** Binding posts on Contact Box.
- B.** Batteries.

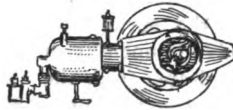

Horizontal Type.

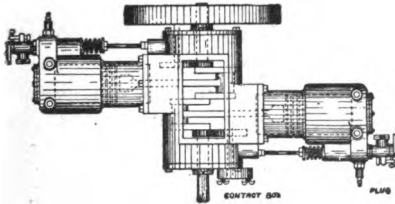

Opposed Type.

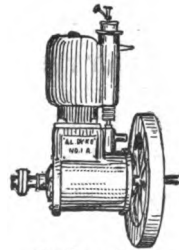

Vertical Type.

**A GASOLENE ENGINE** may be defined as a motor or prime mover which derives its power from the combustion, within its cylinders, of a mixture of gas and air in the proper proportions to form an explosion.

**THE COMBUSTION** or burning of this charge of gas and air is occasionally under close or heavy compression, a result of the inward movement of the piston after the charge is admitted and all valves are closed. The result of igniting this mixture under heavy compression is what is commonly called an explosion, which is nothing more than a quick burning or rapid combustion of the mixture.

**THIS EXPLOSION** causes suddenly a high degree of heat within the cylinder, behind the piston, which heat results in great expansion force, creating an initial pressure against the piston of something 200 pounds to the square inch. This drives the piston rapidly and forcibly on its outward movements, which is connected to the fly wheel by means of pittman and crank shaft, imparts to them their revolving motion and consequent power.

**CONSTRUCTION.**—A successful gasolene motor consists of a cylinder, a piston, crank, connecting rod, fly wheel, (1) small gear on shaft of engine; (2) a gear just twice the size; (3) is shaft of large gear which operates the igniter cam; (11) is the brushes which closes the circuit on the igniter; (4) is the

## DISEASES OF A GASOLENE AUTOMOBILE

cam which lifts the plunger; (5) which in turn lifts the exhaust valve. The inlet valve is opened and closed by suction of piston the sprung brings the inlet valve back to position again; (9) is opening of inlet valve through which the charge of gas is drawn from the carburetter; (8) gasolene connection of carburetter is shown; S is air opening on carburetter through which air is drawn and mixed with gasolene at nozzle point T.

**THE BATTERIES** which supply the electric current is shown at the bottom of illustration B on page 4.

**THE INDUCTION COIL** which transforms the low voltage current into a high tension or high voltage thereby enabling the current to jump across space or resistance is shown as Jump spark coil. The gasolene and the air is drawn in through the inlet valve by the piston being drawn down, it is then compressed when the piston again comes to the top; just before the piston reaches the top (about  $\frac{1}{4}$  inch) the electric current is closed at the igniter cam; just as soon as this current is closed the vibrator on coil is set in motion and a spark leaps across the spark plug point X. This spark ignites the gas and down goes the piston with terrific force; this burnt gas is then released by exhaust valve being opened and the burnt gases go off into the muffler. The muffler deadens the noise.

This motion is again repeated by force of the first explosion.

**TO INCREASE THE SPEED** the lever C on carburetter is opened, which admits more gas and the explosion being more terrific the piston will go down faster.

**TO GET A FURTHER INCREASE OF SPEED** after the lever C is wide open the igniter or brushes are set forward so that it will ignite the charge earlier.

**THE OBJECT** in first cranking the engine is to draw in the gas and compress it.

After first getting the engine started the speed is increased as above stated.

The engine shown in illustration with its gearing for reducing the speed of igniter shaft is called a *four cycle engine* because the igniter shaft is arranged so that the explosion occurs at the second revolution of the fly wheel.

AND HOW TO CURE THEM.

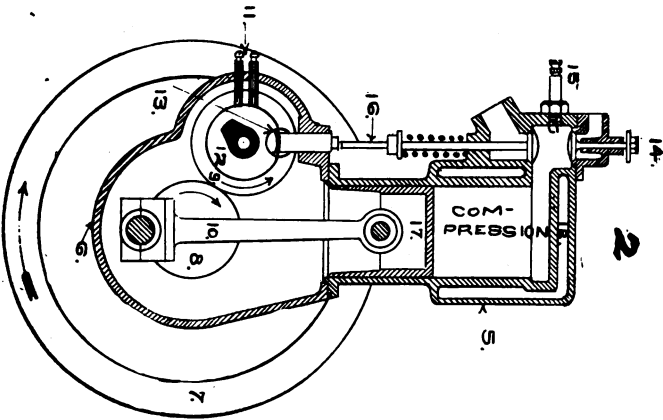
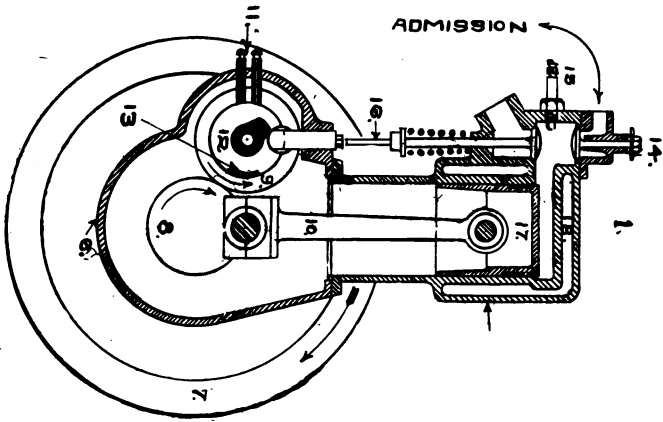

# DISEASES OF A GASOLENE AUTOMOBILE

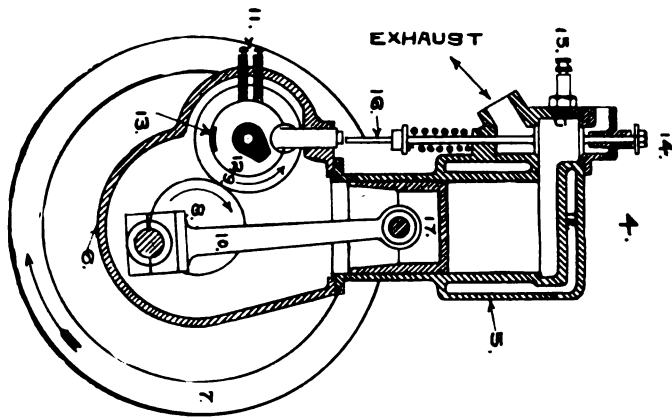
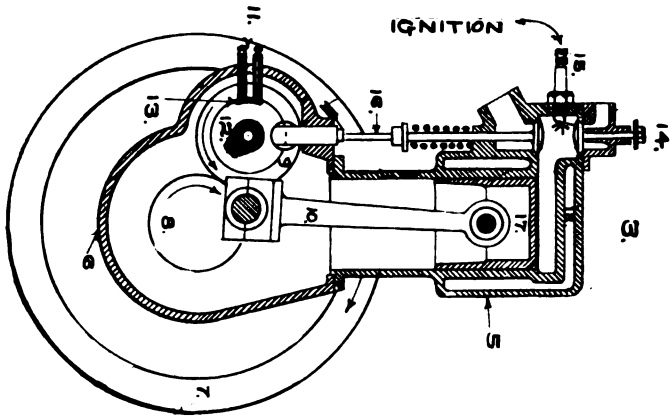

## AND HOW TO CURE THEM.

### Four Cycle and Two Cycle.

Are used synonymously, meaning that an engine completes a cycle in four (4) acts, or that it requires four (4) movements of the piston to complete a cycle as follows:

#### Explanation.

No 1, relative position of engine parts at the beginning of the admission stroke.

No 2, relative position of engine parts at the beginning of compression stroke.

No. 3, relative position of engine parts at the time of ignition.

No. 4, relative position of engine parts at the beginning of the exhaust stroke.

Each operation of the engine extends through the period as 1 to 2 (admission), 2 to 3 (compression), 3 to 4 (ignition), 4 to 1 (exhaust) see cut on page 7.

- |                           |                             |
|---------------------------|-----------------------------|
| 5, Cylinder.              | 12, Exhaust Valve Cams.     |
| 6, Crank Case.            | 13, Commutator Segment.     |
| 7, Fly-wheel.             | 14, Admission Valve.        |
| 8, Valve Gear Pinion.     | 15, Ignition or Spark Plug. |
| 9, Half Speed Valve Gear. | 16, Exhaust Valve.          |
| 10, Connecting Rod.       | 17, Piston.                 |
| 11, Switch Box Brushes.   | 18, Water Jacket Space.     |

No. 1. The cut on opposite page, clearly shows the general detail of an up-to-date gasoline engine, with the admission valve and sparking device; the exhaust valve and half speed valve gears, these outlined in cut. The half speed gears being necessary owing to the necessity of operating the exhaust valve only once for each two revolutions of the crank. The cut also shows the water jacket which is necessary to keep the temperature down to a point so that the heat does not accumulate sufficiently to ignite the gas prematurely causing back firing. The position of crank represents the point at which the exhaust ceases and the admission commences. This cut also shows the cam at the instant exhaust valve is allowed to close; thus the exhaust valve closes simultaneously with the completion of the exhaust stroke and commencement of admission stroke which continues to the position indicated in cut No. 2.

## DISEASES OF A GASOLENE AUTOMOBILE

Cut No. 1, also shows the correct position to set exhaust valve which is usually accomplished by placing engine crank and piston on the inner dead center as shown, then matching the teeth in the valve gears so that the exhaust valve has just closed. The exhaust valve should open a little more than a half revolution earlier than indicated in cut No. 1.

No. 2. Cut No. 2, shows the position of crank and piston at the completion of the admission stroke and the beginning of the compression stroke which is completed in the position as shown in cut No. 3.

No. 3. Cut No. 3 shows the relative positions of the crank, exhaust cam and commutator segment which is mounted in a fibre or insulating material and shows the point of ignition. The electric circuit being completed by this commutator segment completing the circuit by budging the two switch box brushes causing the plug to spark. The resulting explosion drives the piston and crank to position indicated in No. 4.

No. 4. Indicates the relative position of the piston and crank at the instant the exhaust valve begins to open which is a little early of the outer center. The exhaust valve remains open from position No. 4 to position No. 1 when the engine repeats.

- 1st. **ON THE OUTWARD MOVEMENT** of the piston a charge of gas is drawn into the cylinder.
- 2nd. **ON THE INWARD MOVEMENT**, the valves being closed, the charge is compressed in the rear end of cylinder.
- 3rd. **EXPLOSION AND EXPANSION** of the charge under the compression pressure causes the next outward movement.
- 4th **THE SECOND INWARD MOVEMENT** with the exhaust valve open, exhausts the burnt gas. Therefore **two revolutions** of the fly wheel are necessary to complete **one cycle**, consisting of an **inhalation, compression, expansion and exhaust**.

**A CYCLE.**—The four strokes, two outward and two inward—are called a “cycle” and, as may be readily understood, there is thus only one power impulse for every two revolutions of the fly wheel. This power stroke also continues while the crank is traveling through half a revolution, or through an arc of 180 degrees. It is also evident that the cam shaft, for operating



## AND HOW TO CURE THEM.

the valve system of the cylinder, revolves but once for every two revolutions of the crank shaft, with which it is geared. Thus is secured the opening of the charging or "inhaust" valve and of the exhaust at precisely the proper parts in the cycle.

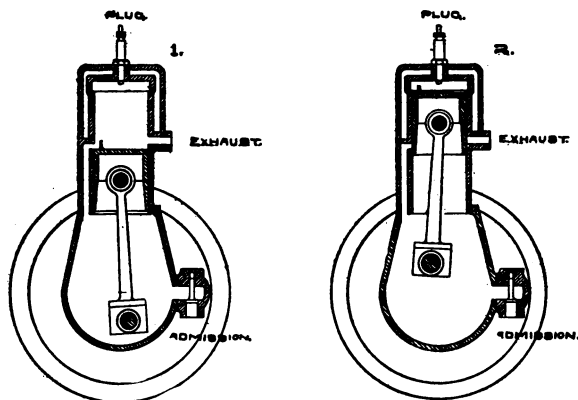

**A TWO-CYCLE ENGINE** accomplishes the four acts, admission, compression, ignition, exhaust, during **one** revolution of the fly wheel; each inward stroke accomplishes the result of supply and cylinder compression, and each outward stroke, the result of ignition, exhaust and recharging.

The two-cycle engine is the simplest gas engine built. It has a number of advantages, viz.: An impulse for each revolution, but a single induction check valve, the piston acts as an exhaust and transfer valve, no valve gears being necessary.

Cut No. 1 shows the piston and crank at the time when the gas from the crank case is transferred to the firing end of the cylinder. In the up-stroke which terminates in position No. 2 the engine performs two functions, compressing the charge in the firing end of the cylinder, at the same time drawing in a fresh charge through the admission valve. The position, No. 2, indicates the relative firing position when the engine runs to the right, or in the same direction as the hands of a clock.

On the down-stroke of position No. 2, terminating in position No. 1, the engine also performs two functions, the explosive charge driving the piston and crank from the upper side of piston, at the same time compressing the next charge on the under side of the piston. As the piston passes the exhaust port and allows the escape of burnt gases, while a further travel of

## DISEASES OF A GASOLENE AUTOMOBILE

the piston opens the admission port, thereby allowing the compressed charge in crank case to transfer or equalize in the firing end of the cylinder. The engine then repeats. As there are two strokes which may be called compression and explosion in each revolution, the engine is naturally called a two-cycle engine. While this engine has many good points, a four-cycle engine outranks it when **all** points are considered, and has proven its superiority by every-day practical service.

**TWO-CYCLE FOR AUTOMOBILE USE.** While it may seem that the two-cycle would be capable of a higher degree of power, as well as a greater speed, it is nevertheless true that its practical performance is different. It is a very satisfactory type for low speed purposes, and in such conditions will develop, as some claim, a power fully 50 or 60 per cent greater than with a four-cycle engine of the same dimensions. This statement is questioned by other authorities; but, as may be readily understood, an engine giving a power impulse stroke in every revolution should, theoretically, have twice the available power capacity of one having a power stroke in every two revolutions only.

This would undoubtedly give about the practical percentage of superiority named above. At high speeds, such as are contemplated in the construction of motor vehicles, **the objection to the two-cycle motor** is that all the functions of inhaust, compression, ignition and exhaust being performed in a single stroke of the piston, **Sufficient time is not allowed for the expulsion of the burned gases,** with the result that the cylinder "chokes itself up," as the saying is, and its contents fall below the explodable point, stopping the engine. It is thus estimated that while a four-cycle engine of a given horse power will run at as high a speed as 1,200 or 1,500 revolutions per minute, a two-cycle engine of the same power can make no more than 300 or 350 revolutions. The same defect in operation prevents the two-cycle motor from attaining the power efficiency otherwise seemingly involved in its constructional theory. It is on these accounts that the two-cycle type of motor has thus far proved unavailable for automobile purposes, where the four-cycle engine has proven eminently effective.

## AND HOW TO CURE THEM.

### Ignition.

**IGNITION BY JUMP SPARK.**—The word ignition covers the entire apparatus for igniting the gas at the proper time.

**THE IGNITION APPARATUS** consists of an Induction or Rhumkoff Coil. This coil as stated previously transforms a low tension into a high tension or high voltage thereby enabling the induced current to jump across spaces at terminals T T.

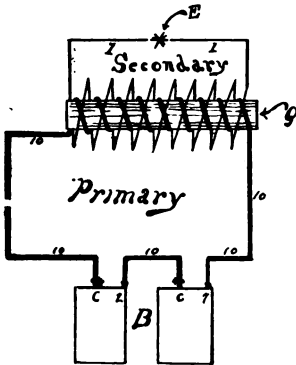

Fig. 21.

In fig. 21 we have a diagrammatical representation of a Rhumkoff Coil in which Q, is supposed to be a bundle of soft iron wires, technically known as the core, is wound a continuous insulated copper wire, 10, of about 14 gauge. The two ends of this wire are carried around to the contact box. Around the outside of the primary coil, 10, is wound another coil of wire, 1, which is of much smaller size, usually about 36 gauge: this secondary coil must be very carefully insulated from the primary coil over which it

is wound. Between the free ends of the secondary coil the spark takes place when the apparatus is in use.

The primary coil, 10, is only a few yards in length, whereas the secondary coil of wire, 1, is usually three-quarters to a mile in length.

The working of this coil depends upon the breaking of the primary circuit, 10, and although the secondary circuit, 1, has no connection with the primary circuit, there will be a spark between the ends of the secondary wire at, E, provided the ends are sufficiently near say  $\frac{1}{8}$  of an inch space.

A spark will be made at every break of the primary circuit by the contact device A S F. Fig. 22. There will be no spark at E, when the primary circuit is completed. The spark occurs at E, only when the primary circuit is interrupted. The contact device

## DISEASES OF A GASOLENE AUTOMOBILE

A S F some times known as the "trembler" or "contact device

or box" may be operated by the motor as shown in figure 22, in which, C, is the coil. 1, is the secondary circuit, 10, is the primary circuit including a battery of cells, b, and the vibrator. The vibrator consists of a cam, A, the finger, F, which is supported by a spring on the stud, S, in such a manner as to make contact with the regulating screw, R, when the finger, F, is forced against the screw by the cam, H. It will be observed in the

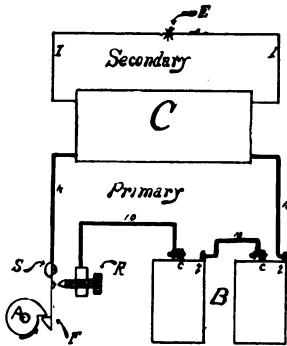

Fig. 22.

drawing that one end of the primary wire, 10, is connected to the stud, S, while the other end is connected to the regulating screw, R. Therefore, when the cam, A, presses the finger, F, against the regulating screw R, the circuit will be complete, permitting a flow of electricity from the battery, B, through the coil, C, and wire, 10, stud, S, finger, F, regulating screw R, and by the remainder of wire, 10, back to the battery, B. As the cam is rotated in the direction shown by the arrow it will come into the position shown. The finger F will then drop into the hollow of the cam, A, by its own elasticity thus breaking the circuit between itself and the regulating screw, R, when a spark will occur at E.

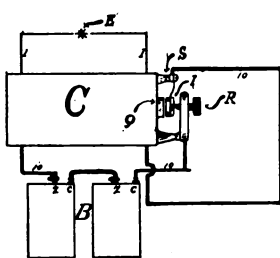

Fig. 23.

IN FIG. 23 we show how the make and break device is operated automatically. By referring to fig. 21 we observe that when the electricity flows from battery B, through primary circuit 10, and around bundle of iron wires Q, that these iron wires will be temporarily magnetized. This bundle of wires that forms the core is very soft, and will lose its magnetism almost instantly.

IN FIG. 23 is the coil with a primary circuit, 10, in which is in-

## AND HOW TO CURE THEM.

cluded battery, B, regulating screw, R, stud, S, which supports (through medium of sensitive spring) the soft iron disc, 1. This disc is supported directly in front of, and about one-eighth inch from the soft iron core, Q, of the coil, C. The regulating screw, R, is set so as to make contact with the soft metal armature, 1, when no current is flowing through the primary coil, 10. When the current does begin to flow through the circuit, 10, the regulating screw, R, and soft iron armature, I, to the stud, S, thence through the primary coil of the transformer, C, back to the battery, the core, Q, of the coil, C, will be magnetized. This magnetism attracts 1, but is instantly released as the circuit is broken with R. Just as soon as it touches R the magnetism again attracts 1, but is again released, and will be again rapidly repeated. The regulating screw, R, is for the purpose of obtaining a more or less rapid make and break, according to the tension of the spring. When this spring, 1, is vibrated rapidly a spark occurs at E. This spark of course is supposed to occur within the combustion chamber of the motor, and in order that this may be accomplished without leakage a **jump spark plug** is employed.

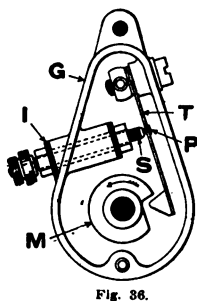

Fig. 36.

92.—Fig. 36 shows a form of mechanism to be used in conjunction with an induction coil with secondary winding and a **jump spark plug**. In this device the make and break of the primary occurs outside of the combustion chamber, but the spark jumps between two points of a spark plug screwed into the combustion chamber. This plug is nothing more nor less than insulating material carrying two platinum wires, one of which is grounded on the engine, the whole being screwed into the combustion chamber. The ends of the wires inserted in the chamber are turned toward each other and separated about 1-32 of an inch. On that end of the plug which remains outside of the combustion chamber there is a suitable thumb screw for attaching one of the wires from the battery, the other wire being grounded on the engine. The action of the device to be described causes a spark to jump between the points inserted in the combustion chamber. The case, G, is usually attached to the gear box.

## DISEASES OF A CASOLENE AUTOMOBILE

Attached to the case is what is known as the trembler, T, consisting of a piece of flat spring steel, with a nose at its lower end. Near its center is a platinum contact point, P. From the opposite side of the case comes an insulated bushing carrying the screw, S, which is so set that it is not quite in contact with the trembler, T. As the cam, M, revolves in the direction of the arrow, it comes in contact with the nose of the trembler, T, and pushes the platinum point, P, still further away from the screw, S. Shortly before the cam arrives at the position shown in the drawing it releases the nose of the trembler, allowing it to fall, producing a vibrating effect, opening and closing the circuit repeatedly between the point, P, and screw, S, and thereby supposedly causing a stream of sparks across the points of the plug inside the combustion chamber. In practice, however, and when the engine is running at high speed, a single spark only occurs.

The device just described in Fig. 36 is the one most generally used. This device frequently causes "misfiring" and is a great source of annoyance by the adjusting screw working loose and contact fails at P.

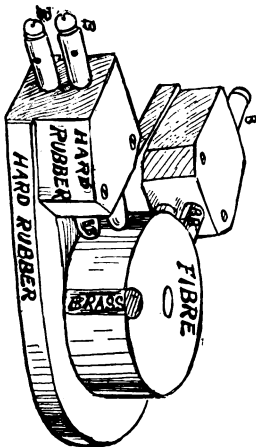

Dyke Contact Box Open— $\frac{1}{2}$  Size.  
For Double Twin  
Type Engine.

Another objection is that the cam is not insulated and it is necessary to ground or connect the secondary and primary in order to use it. It frequently occurs that a spark jumps from the engine to the igniter and contact fails.

The most reliable contact device yet devised is the one shown in illustration Fig. 37. In this device the primary and secondary circuits are both insulated from each other and there is no adjusting screw to work loose. This Brush device is rapidly replacing the "trembler" type.

## AND HOW TO CURE THEM.

**RETARDED AND ADVANCED IGNITION.**—The advancing of the point or period of ignition in a gasolene motor, although not economical, is still desirable in automobile motor use,

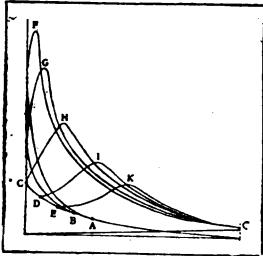

as it affords a means of obtaining a wide range of motor speed in addition to the speed changing devices usually employed. The five diagrams shown in the illustration were taken by the new Manograph or recording device, the invention of M. Hospitalier, from a gasolene motor with a normal speed of 1,200 revolutions per minute.

The letters A, B, C, D, E show the points of ignition and the letters F, G, H, I, K the points of maximum explosive force for each of the five diagrams.

In the first diagram the point of ignition A is about one-third of the stroke of the piston ahead of the dead center; in the second diagram the point of ignition B is about one-fourth of the stroke of the piston ahead of the dead center; in the third diagram, the point of ignition C is at the dead center; in the fourth diagram, the point of ignition D is about one-sixteenth of the stroke of the piston past the dead center, while in the fifth diagram, the point of ignition E is about one-seventh of the stroke of the piston past the dead center. It may be readily seen from the diagrams that the points of complete combustion and the highest explosive force corresponding to their respective points of ignition vary from a point slightly past the dead center to the middle of the outward stroke of the piston.

The letters AF, BG, CH, DI and EK, correspond to the point of ignition and the point of highest explosive force of each of the five diagrams respectively. The first two of the five diagrams, which show the point of ignition ahead of the dead center, demonstrate that the power of the motor is greatly increased by advancing the point of ignition, or in other words, igniting the charge before the piston has reached the end of its compression stroke.





## AND HOW TO CURE THEM.

**CAUSES.**—1. Ignition adjusted too high.

Remedy—Tighten down slightly and clean platinum points. Be sure these points are always bright.

2. Mixture too weak; *i. e.*, not enough gasolene.

Remedy—Open gasolene valve another half point or so.

3. Needle valve in mixer may have become clogged with some dirt or other impurity in gasolene.

Remedy—Open valve wide and blow hard into gasolene tank where gasolene is put in. This will force gasolene out and usually carry the sediment with it.

4. Mixture too rich, flooding motor.

Remedy—Shut gasolene valve a half point at a time till you get satisfactory results.

5. Not finding it as 1, 2, 3 or 4, look for a partial short circuit. The end of a strand or two of the connecting wires may be reaching out, touching some metal portion of the frame or motor.

Remedy—Examine all terminals and gather in all these stray wires, wrap each terminal neatly with a piece of electrician's tape.

6. Points on end of spark plug too far apart. Not liable to happen unless through careless handling. Spark points too far apart are apt to injure coil.

Remedy—Press the curved wire till end is  $\frac{1}{32}$  inch from center point.

7. Badly insulated or short circuited spark plug.

Remedy—Take plug apart and clean carefully and thoroughly, burning off the lubricating oil if necessary, brighten points, adjust right distance, 1-32 inch apart. If it then sparks where it should not the plug is no doubt badly insulated and should be repaired or sent for replacement.

8. Battery cells run down, either from use or by carelessly allowing to become short-circuited. This happens by leaving switch-plug in machine and switch turned on. Sometimes the binders on cells come in contact with the metal of the battery box; this will ruin them.

Remedy—Replace the old cells with new ones, which should test 1 4-10 volts, 15 amperes each.

It is well to notice occasionally the exhaust valve lifter foot, to see that when lever is low it does not hold the valve slightly open.

## DISEASES OF A GASOLENE AUTOMOBILE

**SMOKY EXHAUST.** Causes—1. Too much lubricating oil will give off a white smoke (animal or vegetable oil will also smoke).  
2. Too much gasolene, resulting in imperfect combustion, will give off a black smoke.

Remedy—Look first to your lubricator and cut it down if you are flooding motor; if it does not then stop in a short time cut down your gasolene slightly.

In either case it will be well to look to the spark plug and clean it from smut, sure to show when you have had a smoky exhaust.

Clean screen and mixing valve after a dusty ride. Dust will

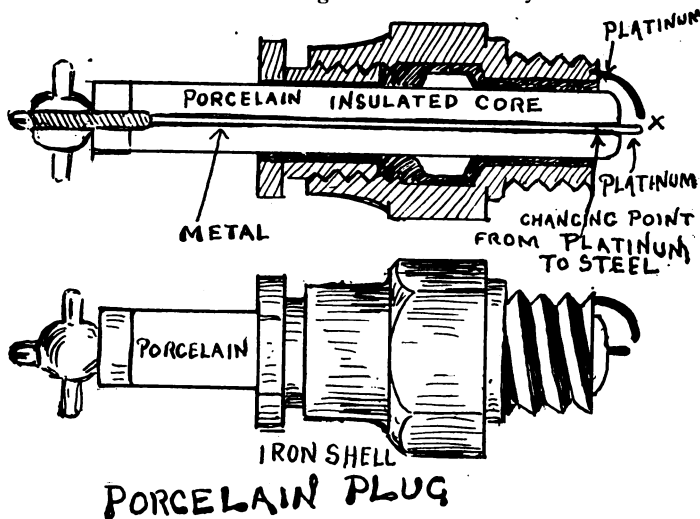

Figure 24.

prevent the necessary amount of air, and you will get a poor mixture and unsatisfactory results.

You cannot run your motor unless you have gasolene in the tank. This fact is sometimes overlooked and the motor blamed for it.

You cannot run your motor if there is any water in the gasolene tank, whether you have gasolene in with it or not. Water is heavy, sinks to the bottom and forces itself out ahead of the gasolene.

## AND HOW TO CURE THEM.

You cannot run the motor unless the gasoline is flowing from the tank to the carburetter in just the right quantity.

You cannot run your motor if the plug is in your pocket.

You cannot run your motor until the switch is turned on. There must always be a good electric connection between battery, spark coil and spark plug.

Spark plug points and contact points in sparker must be kept free from smut, oil or other impurities. Examine these

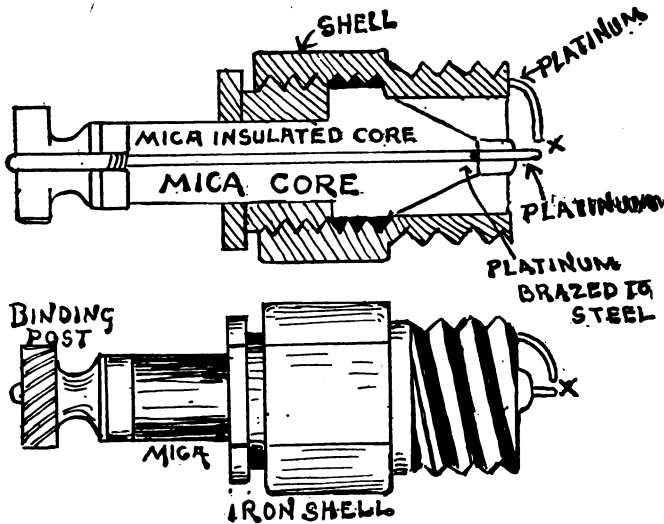

## MICA PLUG

points occasionally and brighten with a piece of fine sand paper, which you should always carry in tool box.

**SPARK PLUGS.**—Referring to spark plugs, in figure 24, we show a sectional view, metal shell threaded, so as to screw closely into the combustion chamber of the motor, and having a flange, turned true with the thread on the shell. Through the porcelain plug passes a wire headed at one end, and threaded at the other end to fit some suitable nut. P is platinum point—one wire from the secondary coil is connected to the nut on porcelain, the other wire from the secondary work-

## DISEASES OF A GASOLENE AUTOMOBILE

ing on coil is connected to a nut on the engine; when the shell B is screwed into the combustion chamber on the engine this wire connected with the nut is also connected to the shell through the metal in the engine acting as one wire. When the circuit is closed on contact box a spark jumps at E as it is the nearest path for it to jump. This ignites the gas in the engine. The porcelain on the plug insulates one wire from the other.

Probably the most of the trouble with engines missing explosion is due to fouled spark plugs. This is generally caused by using a poor grade of cylinder oil which, when subjected to a blaze in the cylinder, turns to carbon; this carbon deposits on the insulated porcelain and accrues to the shells, and instead of the spark jumping from the platinum point to the point in the porcelain and making a spark, it follows the easiest path, which is the carbon, and does not make a spark at all. When this occurs the engine will, of course, "miss fire." The first thing to do when an engine misses fire is to **test your spark plug.** To test the plug see illustration figure 40. **First**, throw off switch;

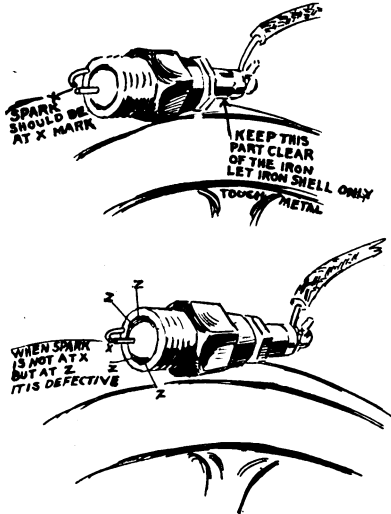

Fig. 40.

elsewhere; probably in the battery, loose connection, or vibrator on coil too tight.

**To clean plug** use a solution of **hydrochloric acid**, washing the point of the plug with a tooth brush, occasionally dipping it into the acid. After washing the plug in this manner rinse it in water.

AND HOW TO CURE THEM.

**THE STANDARD PLUG** used in America is the  $\frac{1}{2}$  inch regular pipe size. Fig. 41 being an exact reproduction of the size.

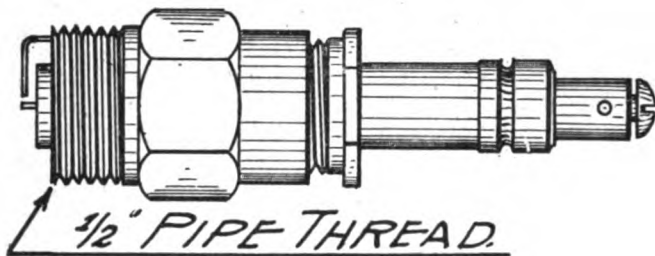

Fig. 41.

**THE METRIC THREAD PLUG** is the standard used in Europe and the illustration shows a full figure view.

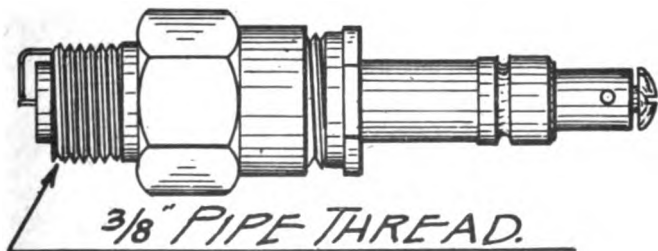
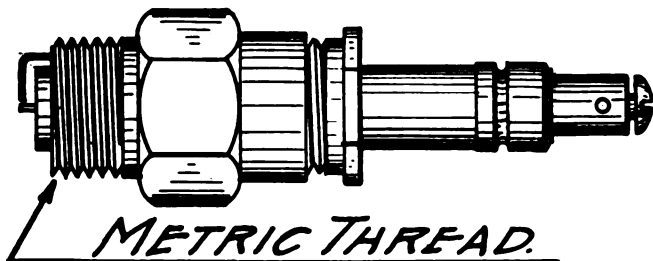

Fig. 43.

**FIGURE 43** shows a full size view of a  $\frac{3}{8}$  pipe size plug used a great deal in motocyale, owing to its small size thread.

## DISEASES OF A GASOLENE AUTOMOBILE

**DISTANCE TO SET POINTS** on spark plugs is about 1-32 of an inch apart. While your coil may be capable of giving a long spark in the open air the length of this spark will be decreased considerably when in the cylinder under compression.

**WHEN YOU HEAR A HISSING NOISE** near the cylinder it is probably due to a leaky spark plug and the best thing to do is to put in a new one.

It is a good idea to carry several plugs with you and the illustration shows a case made especially for spark

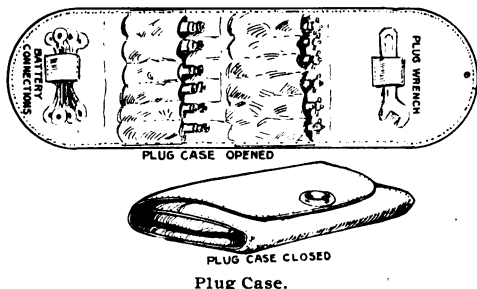

plug. If the hissing is not in the plug it is then either in the packing around cylinder head or inlet valve or

sometimes the **relief cock** works loose.

Sometimes the compression will escape at the base of the sparking plug; soapy water brushed on will locate the trouble. Very often it is simply due to the plug not being screwed home, and a proper application of the spanner will put the matter right. When a new plug is fitted, the washer is apt to shrink from the heat, and it should be screwed up after a few hours' use.

**CEMENT** for plugs can be made of oxyphosphate cements used by dentists. The one called "Hammond's Oxide Cement," is perhaps most easily handled.

With regard to mixing, I would advise to mix a small quantity first, as a test, say two to three drops of the liquid, from a match stick on a glass slab, working in the powder slowly with the blade of a penknife. Do not leave cement too creamy.

When familiar with the mixing, upon which good results depend, it would perhaps be best to fill the plug by making several mixtures, one batch being too difficult to work. Pack in by using the blunt end of a wire nail or the end of a stick slightly moistened to prevent adhesion of cement to these instruments. Have wire and sides of plug dry. By putting in each quantity of cement dry and allowing it to set well, I am sure that the centre wire will be perfectly insulated and the cement impossible to blow through. The heat of the explosions tends to make this cement more dense and adhere more to the sides of the plug.

## AND HOW TO CURE THEM.

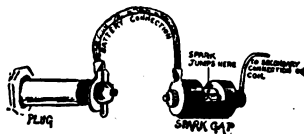
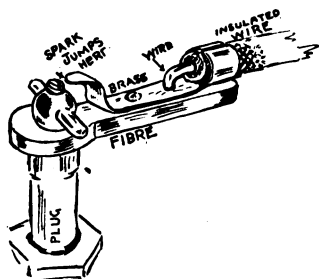

**SPARK GAPS, INTENSIFIERS, ETC.**—The spark gap is a new device for which it is claimed will cause the spark to jump at the end of the points on spark plugs, no matter how sooty they are. The writer thinks the claims are rather exaggerated. I do believe, however, that with a "Spark Gap" and the "Concentrator" such results can be obtained.

The following are clippings regarding the spark gap, which consist of several theories advanced by readers of different trade papers. The writer will not attempt to offer any further explanations, as the entire method is an experiment.

**A SPARK GAP THEORY.**—Eldridge, N. Y.—Editor MOTOR AGE—I read the article "An opinion on spark gaps" by W. H. P. in the Readers' Clearing House of June 11., and was much interested in it, but I must differ with the writer, because I am certain that there is something in the secondary gap that cannot be readily explained.

I too, am an electrician, have a good knowledge of both high and low tension currents, and have also experimented considerably with high tension, high frequency currents, and am quite confident that certain characteristics that develop in high frequency experiments with disruptive discharges may be properly assumed to explain the mystery of the extra gap.

By simply applying Ohm's law of electric currents, which is well known, the theory advanced by W. H. P. is shown to be incorrect. He says: "The intensity of the voltage of the current is reduced to such an extent by the extra gap that the current will jump across the points in preference to the path of higher resistance formed by the carbon."

## DISEASES OF A GASOLENE AUTOMOBILE

Now, as a matter of fact the ohmic resistance of the carbon deposit is much less than that of the air gap between the two points, as may be readily proved by actual measurements, if necessary; and then, too, there are two paths for the current to pass through, instead of one, as inferred by him. We know that, as with other currents, the carbon path, and also the gap between the points, will carry currents inversely proportional to their respective resistances; the current does not follow one path only, but divides itself between the two.

To simply reduce the voltage by the extra gap would mean to reduce the current of the circuit also, and a reduction of current would mean a smaller chance of a spark at the points of the plug, as the drop in voltage between them with a small current is proportionately less than with a strong current. If a reduction of voltage is really all there is to this problem, then the proper thing is to provide battery and coils that will give the correct voltage at the start and not waste a half of the battery power needlessly in the extra gap.

The gentleman's statement regarding the arc light circuit is all right, but does not necessarily explain the matter. He will agree with me that if only one 100-volt arc lamp—one spark gap—could be used to advantage on the circuit referred to, he would think it very unwise to provide a 500-volt dynamo and four other lamps in order to make one operate. He would not think of such a thing, but he would select a 100-volt dynamo for the one lamp—but that dynamo would have the same current capacity as would the 500-volt machine.

While about to experiment with the extra gap I used a plug that was perfectly clean, but poorly insulated, so that my coil, which was easily capable of giving a  $1\frac{1}{2}$ -inch spark, punctured its insulation, and no sign of a spark was visible at the points when first tried without the extra gap.

I then put in the second gap, and was much surprised to see a spark at the plug points at once. I tried this several times with the same results; now I cannot believe that a reduction of voltage—and current—caused the spark when using two gaps. I think, rather, that the effective voltage at the gap was either increased or the nature of the current materially changed and endowed with a greater power of discharging through air.



## AND HOW TO CURE THEM.

My experience with high frequency currents leads me to the conclusion that the insertion of the second gap so increases the frequency of the discharge that the current readily passes through the air gap, even though there is another path for it through the carbon deposit. To support this conclusion I would call attention to the following peculiarities of high frequency currents:

The frequency of a high tension current is enormously increased by each disruptive discharge—air gap—in series with its circuit.

With the increase of frequency comes the ability of the current to cross air spaces—spark gaps—with much greater ease than through solids of high resistance, such as the carbon deposits.

I do not wish to be understood as saying that the above is the solution of the problem. I simply say that to me it is the most reasonable that I have been able to consider in the short time that has been at my disposal for experiment. I hope, however, to conduct a series of extensive experiments in the near future with this wee puzzler, and in the meantime will be glad to hear from others through *Motor Age*.—A. E. D.

**OTHER THEORIES.**—The reason why the use of an extra gap in the secondary circuit will cause a spark to jump across the points of a fouled plug is that the intensity of voltage of the current is reduced to such an extent that the current will jump across the points in preference to the path of higher resistance formed by the carbon deposit upon the insulation of the plug. As the two spark gaps are in series with each other, it follows that with a single gap—the plug alone—the tension of the secondary circuit is 30,000 volts, while with two gaps the tension at each gap will be only 15,000 volts. That this statement is true may be shown by the action of an arc light circuit of 500 volts, with five 100-volt lamps in series in the circuit, and which consequently have a potential of 100 volts each, and not 500 volts, as might be supposed. This simple explanation, therefore, absolutely destroys the claim that the use of the extra gap intensifies the arc or spark at the plug. The real advantage of the extra gap is that the reduction of the voltage, instead of its increase, reduces the liability of the current to leak across the carbon deposit.

## DISEASES OF A GASOLENE AUTOMOBILE

The extra gap will only be found effective so long as the carbon deposit upon the insulation is small, or mixed with oil, which increases the resistance of this path. The arcing will continue at the point of the plug until the carbon deposit is rich enough to form a path for the entire volume of the current, when the plug will cease sparking—but the extra gap will continue to arc. The principal advantage of the extra gap is that it provides a means of seeing whether the secondary circuit is in working order without removing the plug from the cylinder, and the device should be connected in the circuit by a two-point switch to enable it to be thrown in and out of the secondary circuit. The use of the extra gap will never absolutely remove the necessity of keeping the insulation of the spark plug in good condition and free from soot or grease. As long as the batteries are strong enough to maintain the full voltage of the primary circuit, just so long will the extra gap work successfully in the secondary circuit, and when the electromotive force of the batteries falls below the normal point, it will be found necessary to close the extra gap, to maintain an efficient spark in the cylinder.

**SPARK GAP EXPERIENCE.**—Providence, R. I.—Editor MOTOR AGE: Being very much interested in the workings of the extra spark gap, and thinking that other members of the Readers' Clearing House may be of the same state of mind, I would like to describe a rather peculiar experiment which I made a few days ago in connection with an extra spark gap. When about to test an extra spark gap device in connection with a spark plug on a bench, prior to attaching the spark gap device to the dash of my car, I found myself short of wire, and not wishing to detach any of the wires on the car, a piece of brass jack chain was used to complete the secondary circuit. Upon putting the vibrator coil in action a stream of sparks was observed to flow along the links of the jack chain, which at the time laid loosely upon the bench, although forming a part of the secondary circuit as before stated, and the extra gap and spark plug sparked finely in spite of the additional gaps or spaces occasioned by the loose links in the jack chain. The sparking along the jack chain was the cause of my conceiving an idea for a little experiment on somewhat original lines; that is, as far as I am

## AND HOW TO CURE THEM.

aware. A long strip of well seasoned hardwood was procured, and seventeen pieces of bare copper wire of No. 18 B. & S. gauge, about one inch long, were fastened to the wood in a row with the adjacent ends of the wires about one-sixteenth of an inch apart. This apparatus was introduced into the secondary circuit alone. The vibrator coil was brought into action and good sparking was obtained between the adjacent ends of the short lengths of wire. As the sixteen gaps summed up a total length equal to a one-inch gap, it was naturally supposed that a spark would arc or jump across a single gap of one inch in length, but on trying the experiment the spark refused to jump or arc over a greater length than five-eighths of an inch. At three-fourths of an inch a tiny spark would occasionally hop across, but at thirteen-sixteenths of an inch no sparks were visible at any time. Why the secondary current will jump or arc across a number of gaps of fixed length and then refuse to jump across a single gap of more than five-eighths the sum of the individual gaps is a mystery, and I would be extremely grateful if some member of the Readers' Clearing House could enlighten me on the subject.—J. H.

**A CONCENTRATOR** is shown in Figure 43. By the use of this device shunted or connected to your present ignition system it has been actually demonstrated that it will cause a spark to jump at your plug terminus, no matter how sooty your plug may be.

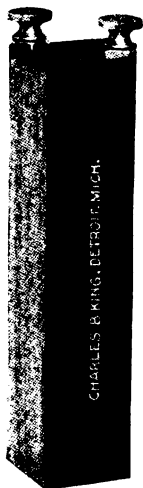

Fig. 43.

**WIRING.**—Too much stress cannot be placed on the proper wiring. To attain good results your machine **must** be wired with good heavy rubber-covered, flexible, stranded wire, especially on the secondary wire which carries the higher voltage from the coil to the plug. The other wires need not be so heavily insulated, but a Number 12 size flexible, rubber-covered, stranded copper wire should be used. Fig. 44 shows actual size of a heavy cable suitable for the secondary wiring and Fig. 45 shows actual size for the primary wires.

**USE ONLY** good connections and ones which will not work loose. Figure 46 illustrates a

## DISEASES OF A GASOLENE AUTOMOBILE



Fig. 44.

copper wire terminal attached to the end of these wires. The terminals are cheap and should be used by all means.

Fig. 47 illustrates a Flexible Battery Connection which is simple yet saves a world of trouble with loose battery connections. Ordinarily common lamp cord is peeled at the

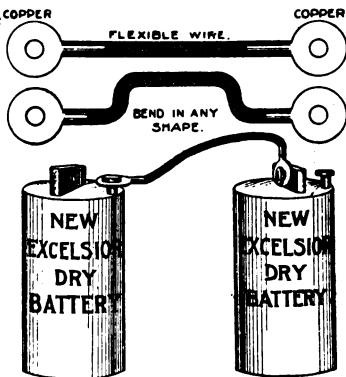

Fig. 45.

end and twisted, then put under the binding part of a battery and if not soldered the nut will work loose caused by the spring tension in the wire and this will cause a loose connection and consequently your engine will occasionally miss explosion and run in jerks. By using the Battery Connection the nut is screwed to the copper terminal which has plain smooth surface and the nut will re-

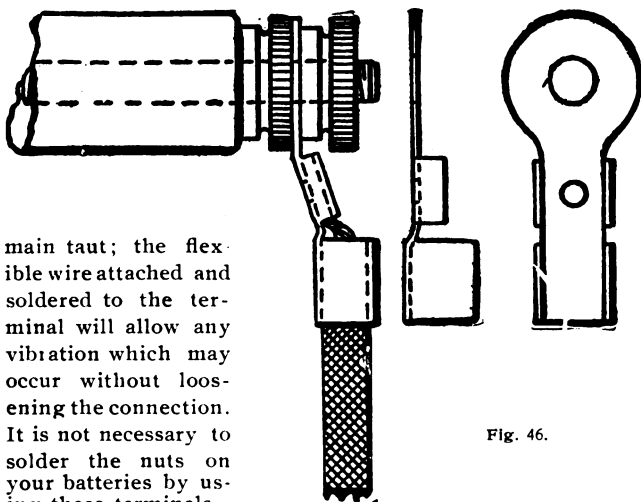

Fig. 46.

main taut; the flexible wire attached and soldered to the terminal will allow any vibration which may occur without loosening the connection. It is not necessary to solder the nuts on your batteries by using these terminals.

## AND HOW TO CURE THEM.

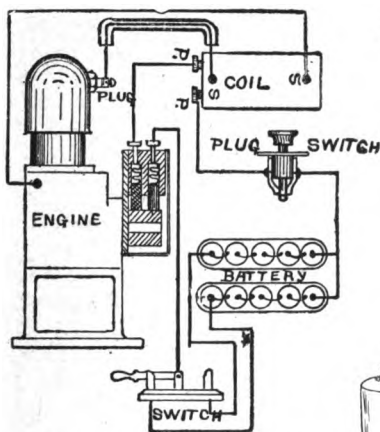
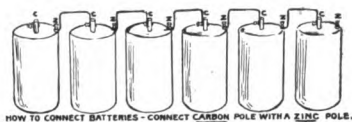

Fig. 48.  
Heavy wire is shown running from plug to coil.

**SOLDERING CONNECTIONS** on batteries heats them considerably and tends to dry up the moisture which they contain and shorten their life. This should never be done.

Illustration Fig. 48 shows method of wiring and proper place to use the large wire and the smaller size.



**BATTERIES** are used for supplying electric current to operate the igniting apparatus.

There are several forms or types—Dry Batteries, Wet Batteries, Storage Batteries.

**THE DRY BATTERY** is the one which is most commonly used on automobiles because of the small space occupied and cleanliness of same. This battery is sealed. It is called an "open circuit" battery, because it is intended to be used where the circuit is open most of the time, such as for ringing electric bells, etc. After using this battery for a short while it will lose its power, but by leaving it stand for a while it will recuperate and be just as strong as ever. There is a limit, however, and about two or three months' actual use will kill the life of the battery almost entirely, and new ones must be substituted.

Owing to the fact that the dry battery loses rapidly while in use, it is advisable to use two sets, and after working one set say for about one hour, the other set should be switched on and previous set allowed to recuperate. This not only gives you an auxiliary set of batteries, but lengthens the life of both sets.

## DISEASES OF A GASOLENE AUTOMOBILE

A form of dry battery is shown us in Fig. 49. This battery is sealed and the contents will not spill. The two sizes generally used are  $2\frac{1}{2}$  x inch and  $3\frac{1}{2}$  x 8 inch.



Fig. 49.

**WET BATTERIES** are also of the open type variety, but when wet batteries are used they are used on boats or for stationary gasolene engines, where room is no object.

The form of wet battery generally used is the **Edison LeLand "Closed-Circuit" type**. They are contained in porcelain or steel enameled jars, and the elements used are peroxide of carbon and zinc, well amalgamated or dipped in mercury. The solution is caustic potash and water.

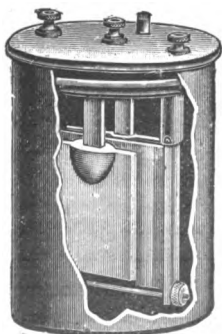

Edison-LeLand.

This battery will deliver a steady current without losing its power for a number of hours. Some of them run for as many as 400 hours. Where space is no object it is a very servicable battery. It would not answer for automobile men, however, as the cleaning is a nuisance; and the voltage being low, it is necessary to use at least eight cells, where only five or six dry cells are needed, and each dry cell being just half the size of the Edison-LeLand.

The small cost of dry cells permits throwing them away when they are exhausted and replacing them with new ones.

## AND HOW TO CURE THEM.



Volt and ampered meter combined.  
American production.

### NUMBER OF DRY BATTERIES

**TO USE** should be either five or six, in order to give the proper voltage to the winding of the coil; to use under this number, in case your batteries get weak after running awhile they will not have sufficient power to cause the vibrator to work on the coil.

**THE VOLTAGE** of a battery means its pressure and usually  $1\frac{1}{2}$  volts in the pressure of ordinary dry cells no matter how large or how small.

**AMPERAGE** is the quantity, and the larger the cell the more current they will give and the longer they will last.

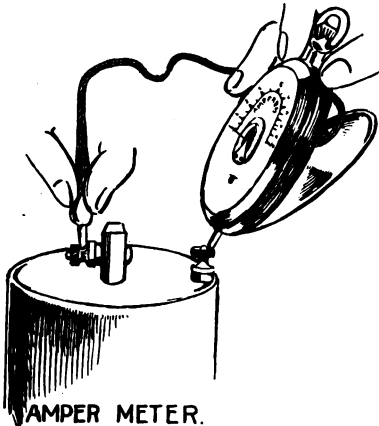

**FIVE** cells  $2\frac{1}{2} \times 6$  will give **fifteen** or more amperes, and are generally safe for use as low as **seven** amperes when five are used.

**CELLS** vary greatly, and when in one case 1,500 miles may be driven with one set, another set may give out in 500 miles.

## DISEASES OF A GASOLENE AUTOMOBILE

While the voltmeter is not altogether as reliable as the ampere meter you can get an idea how they are holding up by putting them into operation, say, by connecting them so as to run the spark coil.

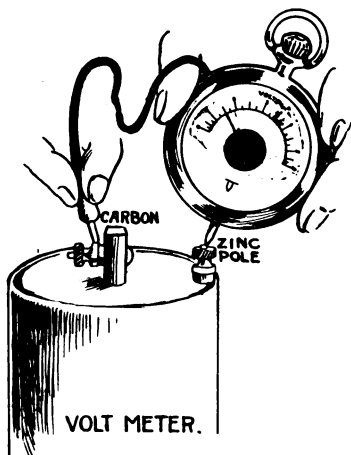

While the cells are discharging test each one of them separately with the voltmeter, and you will probably find that some of the cells are "dead" and not doing their work properly, which will put all the rest of them out of business. Often automobilists think their cells are run out when they have only one bad cell or a bad connection. When the pressure is below one volt a cell is of

no use for operating a spark coil.

**RECHARGING DRY BATTERIES.**—There is really no satisfactory method of recharging dry batteries. They can, however, be recuperated to some extent by drilling holes in the zinc case, just below the sealing compound, and then allowing the cells to stand in a saturated solution of sal-amoniac for 5 or 6 hours. Recharging the dry batteries from bichromate primary batteries will recuperate them slightly but not sufficiently to make the job worth while.

The following was clipped from *The Horseless Age*. The reader may try the experiment.

I have experimented with a used up dry cell battery and found out that a theory that I had, viz., that they were dried out and not used up, is sometimes correct. I bored holes down into each cell and poured in water for ten or fifteen minutes until it was not readily absorbed. This battery gave me three weeks more service. This may help some one out of a difficulty when he cannot get new batteries.

Of course it is necessary that the battery be strong and effective. The proper kind of a battery to use is another much



## AND HOW TO CURE THEM.

discussed question with gas engine manufacturers and users. One advocates a dry battery of a certain number of cells. Another proclaims the merits of the liquid battery with a different number of cells, and so on. As a matter of fact, no battery is too good, and any battery will give poor results if allowed to short circuit. Too many operators forget to open the switch when shutting down the engine, and the result is that the battery runs down more in one night than it would from several weeks' actual use.

**THINGS TO AVOID.**—Keep your switch open when not in use.

When your rig is washed caution your man to not soak the batteries, it will moisten the paper covering and "short circuit" the cells.



Battery Charge and Plug Switch Combined.

Don't lay nails, screw drivers, wrenches, etc., on top of your batteries.

Don't place batteries near excessive heat.

Don't allow loose connections.

Get a battery change switch and a plug switch combined; when you leave your rig take the plug with you.

The following are clippings taken from prominent trade papers. They relate trouble that you may avoid by reading:

**UTILITY OF POCKET AMMETER.**—St. Louis, Mo.—Editor *Motor Age*—I would like to give the readers of *MOTOR AGE* who are operators of gasoline cars the benefit of one of my recent experiences. The ignition mechanism of my vertical, four-cylinder motor is supplied with current from six dry batteries. An extra set is also carried, so that in case of failure one set, the other set may be used.

While out on the road the other day, the motor began to mis-fire badly and finally stopped. The extra set of batteries was switched in and everything went smoothly for about 7 or 8 miles, when the motor again showed signs of mis-firing and finally stopped as before. Both sets of batteries were then connected in series, but with but little better results. The two

## DISEASES OF A GASOLINE AUTOMOBILE

sets of batteries were next connected in parallel and then the motor started. It ran very well for some time, when the old trouble recurred and the motor stopped as before.

The nearest telephone was immediately put into use and a repair man called up, to whom the trouble was related over the wire. He arrived in about half an hour with a new set of dry batteries and the homeward trip was made without any further difficulty. The next day the two sets of batteries were taken back to the supply house from which they had been purchased. The cells were tested with a small ammeter and two cells of one set and three cells of the other set were found to be practically useless, showing scarcely any amperage. The other seven cells proved to be in good condition. I am now the proud possessor of a pocket ammeter and in future will know what to do in such cases. If I had had a pocket ammeter with me the time the trouble occurred, six good cells out of the twelve could have been selected in a few minutes and time and trouble saved.—J. F.

**SHORT CIRCUIT RUNS DOWN BATTERY.**—After a visit to the carriage shop one day for some small repairs, it was found that the batteries were entirely exhausted, and this was rather a surprise, since they had only been installed a very few days. Upon taking up the seat board which covered them a piece of metal was found lying on top of the two sets of batteries and short circuiting their terminals. This piece of metal had been removed from the vehicle by one of the carriage shop people, and for convenience's sake it had been tucked into this place with perfect innocence on the part of that electrically unsophisticated individual.

Hard-rubber tubing can be procured of almost any length and size. By giving the parts to be bent, a liberal coating of cylinder oil and heating over Bunsen-burner, alcohol lamp or otherwise, it will become soft as wax and can be bent in any shape desired. This covering is oil-proof and does not disintegrate as does gum-rubber tubing. Gum-rubber tubing soon becomes hard and full of cracks which extend through to inner part, rendering it useless as an insulator. When the hard-rubber tubing has been bent as described, the flexible wire cable can be strung through it and the tube with its enclosed wire should then be held in place loosely, preferably with leather loops securely fastened.

## AND HOW TO CURE THEM.

**BATTERY TROUBLE**—Editor *Horseless Age*:—The following experience may be of interest to your readers: One day last week I made a run of about 2 miles in my gasoline car to transact some business, which took about half an hour. After the business had been attended to I attempted to start the motor by turning the crank, but it would not go. I then examined the sparking plug, the coil and the interrupter, all of which appeared to be in good condition. After five or six trials the machine started and appeared to have its usual power, and I started for home. After running about half a mile it began to slow down. I went into the slow speed and varied the mixture, but all to no purpose, and the car came to a full stop. After several trials the machine started again, and by short stages I managed to get it home and into my stable, feeling highly gratified that I did not have to be hauled home.

I examined the needle valve and the pipes connected therewith, and the carburetter, all of which I found all right. The next morning my machine started off all right, and I thought my troubles ended for the present at least. But I was doomed to disappointment, for I had the same experience before I got back home. I then called to my aid an expert on gasoline engines. He tried to locate the cause and run the auto, but with no better success than I had had, failing to locate the cause. He left saying, "We must keep trying till we locate the trouble."

I then had the two batteries connected, but obtained no better results. At last I found the cause where I little expected to find it. A short time ago I had a new four cell battery put in. I took that out and obtained four new cells and put them in, and, lo and behold! the machine started off at the first turn of the crank, and has given me no trouble since. On testing the battery taken out we found one dead cell, and that caused all of my trouble by putting all of the other cells out of working order. After taking out the battery with the dead cell the four cell battery left in has taken on a new lease of life and runs the machine equally as well as the first battery, so I am sure that the dead cell caused all of my trouble.

I don't know of anything that will make a man so disgusted with an automobile as to have it refuse to go in a public place

## DISEASES OF A GASOLENE AUTOMOBILE

where it most always happens. At such times when you try to locate the trouble you are sure to be surrounded by a score of curious loafing men and boys, who persist in asking all manner of questions, and then when someone in the crowd sings out in a stentorian voice, "I should rather have a blind hoss," it makes a fellow feel as though he would be glad to sell out mighty cheap.

If the engine stops, first turn the crank slowly to see if the buzzer works. If it does not the vibrator needs regulating or cleaning. To facilitate finding where the crank ought to be when the primary current is closed, you should make a mark on the flywheel when the buzzer is working. Putting this mark in the same place when the buzzer does not work, you can adjust it readily. If when you have placed this mark in the right place you cannot make the buzzer work, then you know that the trouble is in the primary circuit, probably in the interrupter or communicator. If your sparking plug gets covered with soot and refuses to work, you will have to remove this and clean it with sandpaper. Do not use a knifeblade or metal for this purpose. This sooting is an evidence of too much lubricating oil in your cylinder. This may come either from a too free feed from your oil cup, or from an excess of oil in your crank chamber.

This latter oil is splashed up against the piston head and sucked in.

This oil from the crank chamber, as it is generally a low-grade oil, will get charred in the cylinder, and, coating the walls, will cause a roughness, heating and early firing.

This early firing causes pounding, or sledgehammer-like blows in the machine. If this has occurred, and is not due to the spark being too early, which may also cause it, you had better get your cylinder scraped out. I have heard that the use of coal oil for a few minutes at a time in your oil feed will clean out the cylinder. This should probably be done occasionally, say once a month. When the pounding is bad the coal oil will not cure it. I have had to have my cylinder scraped because of poor oil being used in it. From what I can learn thick oils and oils with an asphaltum base are not suitable for use in the cylinder. A thin, greenish oil seems to give

## AND HOW TO CURE THEM.

satisfaction. The regulation of the proper amount of oil is a difficult problem. A drop every one or two minutes is probably enough. When the oiler is once properly adjusted, it ought not to be disturbed. This has given me more trouble than anything else about the carriage. If your engine runs well for a few minutes after flooding the carburetter, then stops, you may be sure that your gasolene supply is too limited, or the opening for the gasolene may be plugged.

If the engine runs for a variable time, probably your inlet valve may be sticking. In my machine this can be watched while the crank is turned. In turning the crank always keep away from it, so that if it should fly back you will not be injured. Sometimes the accelerator button sticks and so holds your spark advanced. Of course, one should see that his battery connections are perfect, and test them by connecting the terminals.

### Storage Battery.

The storage battery is made up of lead plates. These plates are coated on the negative side with litharge paste and on the positive side with red lead. The solution nine parts water to one part sulphuric acid. This battery is generally enclosed in a tar-coated wood box and sealed on top, with only a small vent hole for the gas to escape when it is charged.

This battery is of no use until it has been charged by a current of electricity. After once being charged it will hold its accumulative current for some time. The storage battery is used a great deal where there are facilities for recharging them when they run down. Storage batteries must be charged from some other sources of electrical energy.

**THE LEAD STORAGE BATTERY.**—A Storage or Secondary Battery is not a generator of electrical energy as is a primary battery or dynamo. When a current flows from a primary bat-

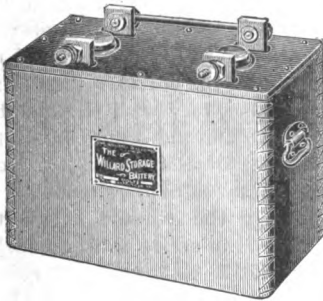

## DISEASES OF A GASOLENE AUTOMOBILE

tery a destructive chemical change takes place within the battery, which in turn produces the current. After the action has continued for a considerable length of time, the battery becomes worthless. It has given up its energy.

In order that electrical energy may be taken from a storage battery, a current of electricity must first be passed through the battery. A chemical but not a destructive change takes place within the plates of the cells. During discharge a reverse chemical change takes place and the plates resume their original condition. Thus it is apparent that a storage battery, if properly made, can be used over and over again, several hundred times in fact, without materially impairing its condition. Due to the chemical changes involved, the whole of the energy required to charge a battery is not available as useful current upon discharge; consequently, in determining the size of battery to be used, its efficiency at various rates of charge and discharge must be taken into consideration.

**VOLTAGE.**—By far the greater number of primary cells in general use have an electromotive force (electrical pressure) of less than, or just about, one volt; moreover, they have a very appreciable internal resistance so that when a number of cells are connected in series, the voltage across the terminals of the series, is much less than is the sum of the voltages of the individual cells. The voltage will also vary with the quantity of current drawn from the cells. On the other hand, the storage battery has an electromotive force of about two volts and an internal resistance so low as to be negligible in all ordinary computations, consequently the voltage across the terminals of a number of storage cells in series will be equal to the combined voltage of the individual cells and will remain practically the same, irrespective of the quantity of current which is flowing from the battery. Many types of primary batteries are limited to open circuit work, for the reason that Polarization, and consequent lowering of voltage, takes place in a short time after the circuit is closed. A storage battery will work equally well on either an open or closed circuit; it will give out a small or large current continuously or intermittently under practically the same voltage; thus it becomes apparent that a storage battery is an almost ideal source of current.

## AND HOW TO CURE THEM.

**INSULATION.**—The acid of one cell of a series must be insulated from that of the neighboring cell of the series; otherwise the two sets of elements will tend to act as one element of half the original voltage of the two cells but of double the ampere-hour capacity. It is always advisable to rest each open type cell, if in a glass jar of considerable size, on a glass or wood sand tray, the tray and in turn to rest on glass or porcelain insulators. Properly sealed cells can be placed side by side with no insulation between them other than the jars in which they are contained. Small cells are sometimes placed on wooden shelves with no insulation between the jars and the shelves. When this is done, care must be exercised in keeping the shelves perfectly dry. Such shelves, and in fact all woodwork in the neighborhood of open type cells, should be kept well coated with shellac varnish.

The Positive plates of an element must be carefully insulated from the negative plates; if at any time they should happen to touch while immersed in the electrolyte; or if any foreign substance, which acts as a conductor, happens to connect two dissimilar plates, they will immediately discharge their current and sometime a destructive action takes place. Likewise care must be taken to prevent the exterior terminals of an element from becoming accidentally connected by a conductor, as this will short circuit and rapidly discharge the cell. When a cell is short-circuited, the acid boils violently and the individual plates show a tendency to bend one toward another. "Buckling" is the technical name given to this action. In cells having well designed plates and the proper kind of separators, this action is not to be feared, even though the cells be repeatedly short-circuited. Cheap cells having wood separators will not hold their charge for any considerable time, as the wood soon carbonizes and acts as a conductor, thus permitting leakage to take place between the plates. Complete cells having wooden separators can be produced and sold for about twenty per cent. less than cells having hard rubber separators of the best quality.

**CAPACITY.**—The capacity of a cell is equal to the product of the number of amperes at which the cell is able to discharge into the number of hours through which it can maintain that dis-

## DISEASES OF A GASOLINE AUTOMOBILE

charge. The capacity of a battery depends on the number and size of the plates in the individual elements of the cell; increasing the number of plates increases the storing capacity, but does not increase the voltage of the cell. If the elements are not kept fully covered with electrolyte, the capacity of the cell is lowered in proportion to the amount of element surface which remains uncovered; moreover unusual chemical reactions are liable to take place which tend to destroy the portions of the damp plates thus exposed.

The capacity of a battery is expressed in ampere-hours. For example, a particular cell will, on discharge, give twenty-five amperes for eight hours, or it has a total capacity of 200 ampere-hours, when discharged at the normal (eight hour) rate. If discharged at a higher rate, say five or three hours, the total capacity will be somewhat less. For example, the above cell will discharge at the rate of thirty-five amperes for five hours; thus giving a total capacity of 175 ampere-hours; or it will discharge at the rate of fifty amperes for three hours, giving a total capacity of 150 ampere-hours; hence it is apparent that increasing the discharge rate decreases the total capacity of the cell.

The watt-hour capacity of a cell depends in a considerable measure on the density of the acid used. Up to a certain point, the higher the specific gravity of the electrolyte used, the greater will be the capacity. Traction batteries are usually supplied with electrolyte of high specific gravity. Care must be exercised not to permit them to be discharged too low or to remain idle for any considerable length of time without being thoroughly charged; as the plates of the cells are much more liable to destructive action when electrolyte of high specific gravity is employed.

Much depends on the quantity of acid used. Some cells, particularly those intended for traction purposes, fall far short of the rated capacity for the reason that there is not sufficient acid present to possibly permit of the necessary chemical reactions which must take place in order to produce this capacity. Cells having a generous allowance of electrolyte will show a much more uniform voltage throughout charge and discharge than will cells which have just barely sufficient electrolyte.



## AND HOW TO CURE THEM.

**TESTING.**—Tests made to determine the efficiency and internal resistance of cells are, in most cases, quite valueless; and are usually very misleading, unless made by an observer who has had considerable training and experience in this particular work; and who is provided with instruments of great delicacy and accuracy.

To determine the capacity of a cell or battery at a given rate of discharge, is a comparatively simple matter, and may be made by the ordinary observer, who is provided with an accurate ammeter and volt meter. The graduations of the instrument should not be out of proportion to the work in hand. Thus, a voltmeter whose smallest division is one volt should not be used to determine the voltage when a single cell is being tested; an instrument reading tenths of a volt should be used.

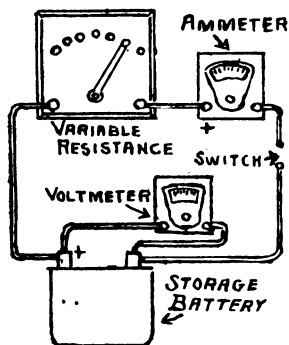

Fig. 1.

The diagram shows the general arrangement of connections for making a test. It is usually customary to vary the resistance so as to maintain a constant current throughout discharge. To test a cell, charge fully; the voltmeter should indicate at least 2.5 volts while the charging wires are still connected.

Throw over the switch so as to permit the cell to discharge; and quickly adjust the variable resistance, so that the ammeter indicates the desired current. Read the instruments at least every half hour throughout the test; during the last hour read every 15 minutes and carefully adjust the resistance so as to maintain a constant current. Do not discharge below 1.8 volts. The capacity of the cell is equal to the product of the current in amperes, multiplied by the number of hours during which the current was maintained. To obtain the watt-hour capacity of a cell, the average voltage throughout discharge must be determined; this, multiplied by the total capacity in amperes, gives the watt-hour capacity of the cell.

All tests should be at least satisfactorily duplicated before any confidence is placed in the results obtained.

## DISEASES OF A GASOLENE AUTOMOBILE

**ELECTROLYTE.**—The electrolyte used in a storage battery is made up, roughly speaking, of four parts of water (by volume) to one part chemically pure sulphuric acid. Nothing except distilled water should be used; freshly caught rain water may be used in case distilled water cannot be obtained. Although it is considerably cheaper, never commercial sulphuric acid, as it will ruin a battery in a short time, due to the presence of iron in the commercial acid. In mixing electrolyte always use a glass or an earthenware jar; slowly add the acid to the water and let stand 12 hours to cool before using. In mixing electrolyte, never add water to acid.

The electrolyte should have a specific gravity of 1.2. This is usually written and pointed off as 1200. The specific gravity of a solution is usually determined by the use of Beames' Hydrometer, which is an instrument so designed that the zero of its scale is on a level with the surface, when immersed in pure water. The hydrometer will rise until the 25 degree mark is on a level with the surface when sufficient acid has been added to raise the specific gravity to 1200. A hydrometer can be purchased for about \$1.00 should always be used in determining the specific gravity of electrolyte. The acid should always cover the top of the plates by at least  $\frac{3}{8}$  of an inch, and, when fully charged, should be tested every few weeks with the hydrometer.

When a cell is discharged, due to a chemical action which takes place, water is formed in a rather considerable quantity, thus lowering the density of the solution; the reverse operation takes place when the cell is being charged; hence the reason for taking the specific gravity reading when the cell is fully charged. Do not use distilled water from an ice plant, as it is almost sure to contain ammonia. The presence of the following substances in the electrolyte tend to destroy the plates; Chlorine, iron, copper, and the nitrates.

**CHARGING.**—The electromotive force of the charging circuit should always be at least 10 per cent higher than the voltage of the battery. Use a **direct** current; an **alternating** current **cannot** be used unless transformed. If possible, a cell or battery should be charged at what is known as the normal charging rate, or preferably at a slower rate, for the slower a

## AND HOW TO CURE THEM.

battery is charge, the greater will be the quantity of energy stored. The normal charging rate is usually taken to be eight hours, irrespective of the capacity of the battery in amper hours. Charge the battery until the voltmeter shows 2.5 volts while the live wires are still connected. Overcharging does no particular harm, but energy is wasted in so doing. In charging, hydrogen gas is given off, which, together with oxygen from the atmosphere, forms an explosive mixture; therefore, keep flames and sparks away from the battery. The danger from this source need not be considered when the care of open type batteries is under consideration, but should be borne in mind if the cells are of the sealed type. Always remove the cap from a sealed cell during the charging period, in order that the gas may have a better chance to escape than provided by the small hole in the top of the cap. When the cells are nearly charged, bubbles of gas are given off very violently from the plates. The temperature of the electrolyte rises several degrees when they are nearly charged. It is advisable to materially decrease the charging rate toward the close of the charging period. From time to time, each individual cell of a battery should be tested for its voltage. If a cell does not appear to be working properly; i. e., if it is low in voltage, disconnect it at once, remove the elements, rinse them in clean water, separate the plates and remove the separators, so as to detect any small particles which may have caused a short circuit. Likewise, make sure that the electrolyte of the cell has the proper specific gravity.

### TO CHARGE FROM AN INCANDESCENT LAMP CIRCUIT.

—In order to charge from an ordinary 110 volt lamp circuit, it

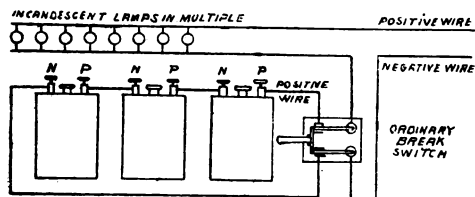

FIG. 2.

is necessary to place lamps or other resistance in the circuit in order to prevent an excessive flow of current. If it is desired to charge a few cells connected in series, at

the rate of four amperes per hour, connect 8 ordinary 16 C.

## DISEASES OF A GASOLENE AUTOMOBILE

P.-110 volt lamps in multiple, each of which will pass one-half ampere, consequently the total current flowing equals four amperes. If but a few cells are connected thus in series, the lamps will burn fairly bright, and 4 amperes will pass through the cells as stated. When a number of cells (say 25) are being charged, the lamps will burn very dim, due to the increased resistance of the added cells, and several more lamps must be added in order that a current of 4 amperes may pass through cells. If charged on a 110 volt circuit, any number of the cells, up to 40, may be connected in series with a multiple bank of lamps, rheostat, or other resistance.

The cost of charging 40 or less cells connected in series from a 110 volt circuit is the same as when charging a single cell. To one not familiar with the laws of electricity, this may appear enigmatical at first thought; it must be remembered, however, that when a single cell is being charged, the energy is mainly expended in overcoming the resistance inserted in the charging circuit in order to prevent an undue flow of current.

**DISCHARGING.**—At low rates of discharge a battery gives a much higher efficiency than at a high rate of discharge. In discharging, the current is supposed to flow out from the charging terminal, so that care should always be taken to connect the positive discharging wire to the positive terminal. If it has been fully charged, a cell, for the first few minutes of discharge, will show a much higher voltage than it will throughout the remainder of the discharge; this is thought to be due to the presence of hydrogen on the spongy lead (Negative) plate. When this has been oxidized there remains the lead surface, between which and the peroxide (Positive) plate, the voltage falls slowly to 1.98 and continues to discharge at this or a little higher voltage throughout the major portion of the discharge period. Do not discharge a cell below 1.8 volts. In discharging beyond this point, the drop in voltage is very rapid.

Besides the drop in voltage and the change in the specific gravity of the electrolyte of the cell, another method of determining when it is nearly discharged, is by the appearance of the positive plates. When fully charged, the plates are a deep chocolate color; on discharge they assume a dull brown.

**IDLE CELLS.**—If a cell is to remain idle over two months, charge fully and then remove the electrolyte. Rinse thoroughly with water, dry and set away. When the cell is to be left standing for a very long period, draw off the acid, fill the cell with pure water and charge fully. After this the water, now slightly acidulated, can be removed, the plates thoroughly washed and set away.

AND HOW TO CURE THEM.

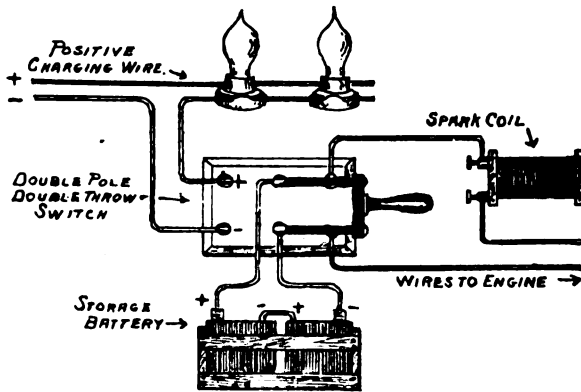

Fig. 81.

**STORAGE BATTERY CONNECTIONS.**—Fig. 81 shows method of connecting storage battery to spark coil and to operate ignition in engine. Also shows how to connect with incandescent lamp circuit to recharge. The current from this incandescent lamp circuit must be **direct** current and not **alternating**.

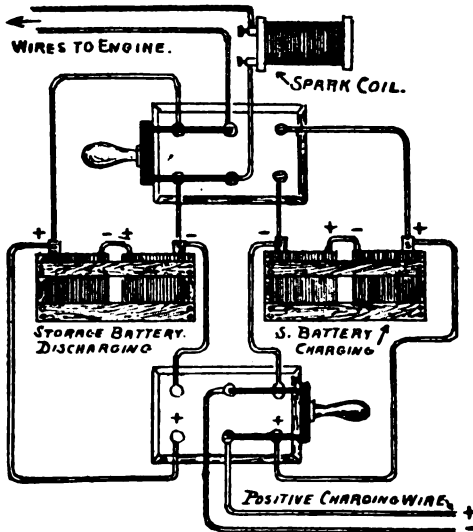

Fig. 82.

## DISEASES OF A GASOLENE AUTOMOBILE

Fig. 82 shows plan of using two sets of storage batteries. One set is being charged while the other set is being used; one supplies current to the engine from one to three weeks, the other is charged in from one to two days and held in reserve until the first battery is nearly exhausted; at which time it is thrown into service and the first battery set charging by merely reversing the switches.

Other methods of connecting up the two batteries to a single switch block or to switches of a different type can be readily devised. The method illustrated has given good satisfaction. The cost of maintaining a system of this kind is almost nothing as compared with the cost of maintaining a primary battery.

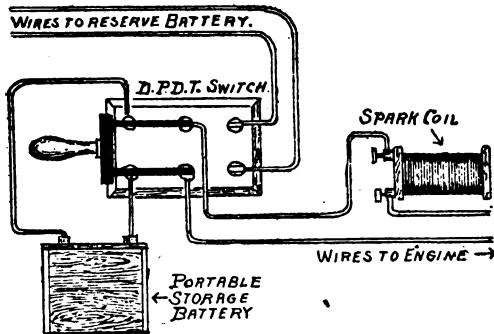

Fig. 83.

Fig. 83 shows plan of using a set of dry batteries or reserve batteries and storage battery. In case the storage battery runs out the dry battery supplies current.

Third method: A portable battery can be profitably employed. Batteries will supply current to an engine for at least three weeks on one charge; usually the battery can be used for five weeks without recharging. If the battery cannot be taken away and charged while the engine is shut down, two batteries should be used. If connected as shown in Fig. 83, a change can at any time be made from one battery to the other without stopping the engine.

## AND HOW TO CURE THEM.

**CHARGING FROM A LIGHT CIRCUIT.**—As the voltage of a light circuit is usually 110 volts, it is of too high a tension for charging a storage battery directly. It is therefore necessary to introduce a resistance into the circuit to keep the charging current down to the correct amount, which should preferably not exceed two amperes.

For ordinary use a single 32-candlepower lamp connected in series with the battery is all that is necessary and will charge a 10-ampere-hour battery in ten hours. If quicker charging is desired two 32-candlepower lamps should be connected in parallel with each other and in series with the battery, which may then be charged in five hours.

Care should be taken to connect the **positive** pole of the battery to the **positive** pole of the light-circuit. To ascertain this correctly, place the ends of the light circuit wires in a glass of water slightly acidulated with a few drops of malt vinegar or sulphuric acid. When the current is turned on bubbles of gas will appear at the ends of one of the wires. This is the negative wire. The other wire will consequently be the positive one and should be connected to the positive pole of the battery.

**THE BATTERY.**—Don't let the battery stand uncharged longer than is absolutely necessary. Its elements are very liable to sulphate.

Don't experiment nor disobey the instructions given you, as your instructors certainly know best what to do and what not to do.

Don't let the solution slop all over the terminals and in the body of the vehicle. Soaked up trays are frequently the cause of batteries discharging themselves while doing no work.

Don't make your own electrolyte when advised to buy it of the makers of your battery. They may have a good mixture, the composition of which they desire to keep secret.

Don't try to make the battery take a full charge when the electrolyte is far below the plate tops, as the capacity of the battery is, generally speaking, in proportion to the plate area covered by electrolyte.

Don't light matches around the cells while charging, because hydrogen is then given off, and this gas is very explosive when mixed with air.

## DISEASES OF A GASOLINE AUTOMOBILE

Don't spark the batteries during nor after charge. This is deliberately short-circuiting them and is a pernicious habit to form.

Don't put your battery to charge unless you positively know you can be on hand to remove the charging current at the proper time. You may have an engagement and forget that you have any batteries at all.

Don't charge your battery at a higher rate than is advised by its makers, nor discharge it beyond the point indicated by them. All storage cells are designed to take in and give out certain quantities of current in certain lengths of time, and their charging and discharging depends upon these capacities.

Don't take your vehicle out until the battery has been thoroughly charged or you may be towed back by some friend.

Don't deliberately try to run the "juice" all out of your battery, or you certainly will have to be towed in.

Don't fail to test each of your cells individually and at frequent intervals with a low-reading voltmeter, and if any are found to read far from an average normal, lose no time in overhauling them, as bad or low-reading cells are nothing else than spurious resistances inserted in a battery circuit.

### The Dynamo.

The most satisfactory way to generate the electric current is by the use of a dynamo. The objection previously to the dynamo was the fact that in starting the speed of the dynamo would not be sufficient to generate the current and if it was speeded up to start the engine then the dynamo would be speeded too fast when the engine attained its

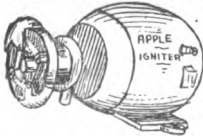

Apple Igniter.

speed. This difficulty has been overcome by means of a governor which gives the dynamo the **same speed** no matter how slow or how fast it may run.

**BEVEL FRICTION GOVERNOR.**—In using the Bevel Friction

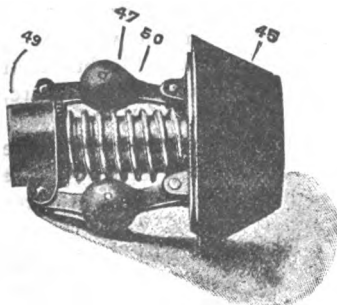

Governor it is necessary to have either a bevel on the edge of the fly-wheel, with the dynamo at right angles to the wheel; or to set the dynamo at an angle to the face of the wheel, as shown in cut on page 79. The Bevel Friction Governor operates as follows: the friction (45) is brought into contact with rim of the fly wheel by means of

spring (50), causing it to rotate, and it in turn rotating the



## AND HOW TO CURE THEM.

weights (47), which are fulcrumed on the yoke (49). The weights expand, and in so doing draw friction (45) away from rim of fly-wheel, preventing speed of dynamo from going higher than adjusted.

This same type is supplied by the manufacturers with flat face pulley.

A very well known dynamo for ignition purposes, with the governor attached, is the "Auto-Sparker." By referring to

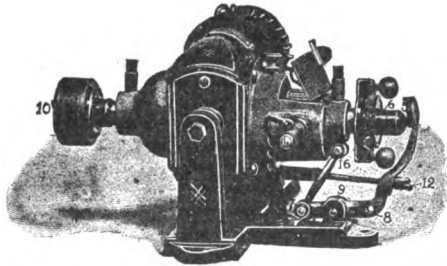

Fig. 1. The Auto-Sparker. The Motsinger Dynamo.

the illustration, when the engine takes the first explosion, and finally goes up to its full speed, it will be seen that unless prevented, the Auto-Sparker will run from six to twenty times as fast as it should. This is prevented and regulated by a governor on the end of the armature shaft (Fig. 1), which runs through the machine from 6 to 10 (Fig. 1). When the speed of the shaft reaches its normal, the governor balls fly out, pushing steel sleeve 6 out against steel plate 5, which is on one end of the lever and which is pivoted at 9. This causes the other end of lever at 7 to raise up, and being connected to the body of the machine at 16 it raises that side of the machine up, since the entire machine is swung like a bell in the frame at point 1 and point at opposite side not shown in Fig. 1. The machine being under the fly wheel and being in contact with same just above the point 10 on the friction pulley. Such action by the governor will cause the other end to go down away from the fly wheel, thereby reducing the speed, so that between the governor and the spring, which is adjusted at 12, the machine keeps a constant speed, no matter what the diameter of the fly wheel or the speed of the engine may be. The

## DISEASES OF A GASOLENE AUTOMOBILE

spring serves the double purpose of pushing the friction pulley against the fly wheel and acting as a tension on the governor. By tightening or loosening the screw 12 the speed of the Auto-Sparker is increased or diminished, which in turn increases or diminishes the size of the spark.

The Auto-Sparker is pivotally mounted on its base so as to allow for slightly imperfect fly wheels, and to allow the action of the governor and spring forcing the pulley out of and into contact with the fly wheel by which action the speed of the dynamo is controlled, the regular partly-lift and slip action. This keeps the paper pulley perfectly round and smooth if the fly wheel is emiered off smooth. When the dynamo is perfectly set, this tension spring is pivotally strained about one-tenth of an inch, and constantly held in this position by the contact of the friction pulley with the fly wheel. When the thumb-nut is unscrewed to its last thread, the speed of the dynamo is about 600 revolutions per minute, and the amperage is, say, one, and the voltage is, say, three. By screwing down the thumb-nut the position of the Auto-Sparker is unchanged, but the contact of the pulley and tension of the governor is increased, until a speed of 1,200 to 1,300 revolutions per minute may be had and the amperage is, say, three, and the voltage ten. A good spark can be had at a speed of 700 revolutions per minute, and the speed should not exceed 1,200, as at that speed sufficient current is had to spark any gas engine, whose points are in reasonable order.

## Carburetters.

There is technically no difference between a mixing valve and

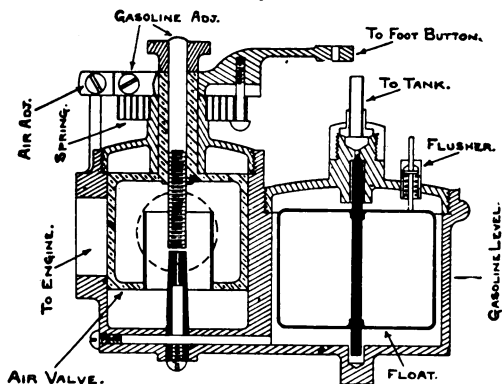

**DYKE'S FLOAT TYPE CARBURETOR.**

As the engine draws its charge the float and needle valve allow

a carburetter. A mixing valve is one form of carburetter, of which there are a great many types. A float-feed carburetter owes its name to the fact that the level of the gasolene in the vaporizing chamber is regulated by a float which operates a needle valve, opening or closing it as it falls or rises.

## AND HOW TO CURE THEM.

the supply to be replenished. The gasolene flows to the float chamber through the needle valve by gravity. In the spray type of carburetter, no float is employed, the gasolene being fed by means of a pump or by air pressure to the atomizing chamber, where it is sprayed and mixed with incoming air on its way to the motor cylinder.

The advantages in using a float feed carburetter, are in getting a greater regulation of speed, higher speed and better mixture. Probably the best known type of carburetter is the Dyke Float Feed. All other float feed carburetters are similar, and the description of this one will give the reader a general knowledge of them all.

**OBJECT IN THE CARBURETTER** is to make gas out of raw gasolene. This gas is then drawn into the combustion chamber through the inlet valve; compressed by the piston and ignited by the electric spark. Naturally the explosion taking place causes the piston to go down, thereby giving momentum to the fly wheel.

### **THE ACTION OF THIS CARBURETTER IS AS FOLLOWS:—**

When the valve on gasolene tank is opened, the gasolene flows to B (Fig. 1), and passes through a gauze strainer and fills chamber No. 1 (Fig. 1) to a point approximately as indicated (Fig. 2). The buoyancy of the float presses the spindle it carries into the small hole above it, preventing the further admission of gasolene to the carburetter. This is one of its **most valuable features**, rendering it very economical and safe.

When the engine is started a vacuum is formed in the space surrounding the air valve, and the gasolene is drawn in and instantly atomized and mixed with the air which is drawn in at the same time.

The amount of gasolene vaporized is always exactly in proportion to the demand made upon it by the engine. **There is absolutely no waste.** The rate of flow of gasolene to secure a proper mixture is adjusted by the knuckled head screw D (Fig. 1), and when once properly adjusted is clamped by the small lock screw directly under it.

The screw named "air ad." (Fig. 2) is placed at such a point that, when against the stop F (Fig. 1) the engine just continues its motion.

## DISEASES OF A GASOLENE AUTOMOBILE

It can instantly be brought to full speed by pressing a foot button which is placed at the driver's foot. This button is connected with lever C (Fig. 1) by means of a rod or wire. When this lever C is opened it swings the air valve around in line with the passage marked "to the engine or G," allowing a full charge to enter.

When the foot button is released, the spring E (Fig. 1) closes or brings lever C back to stop F (Fig. 1), thereby closing the air valve, and the engine drops to its lowest speed.

When starting, especially in cold weather, the Flusher "A" should be pressed for a couple of seconds before turning the crank. This allows a small amount of gasoline to escape into the air chamber, and furnishes the first charge.

The operation is entirely automatic.

**CARBURETTER DIRECTIONS.**—Directions for attaching and using Dyke's Float Feed Carburetter.

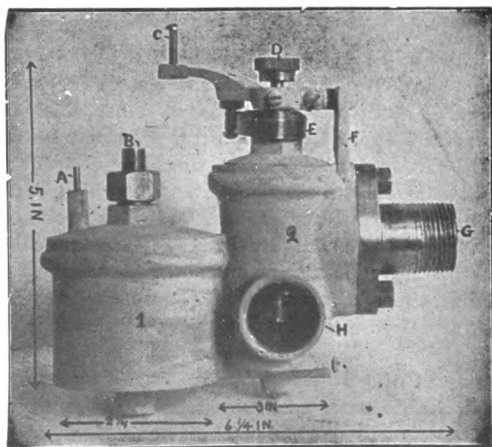

Fig. 1.

Half Tone View of the Dyke Carburetter.

**Connect** the connection "G" to your pipe leading to your inlet valve on engine. (In ordering give size of pipe leading to your inlet valve.)

## AND HOW TO CURE THEM.

**Connect** a  $\frac{1}{8}$ -inch copper pipe leading from your gasoline tank to connection "B." The  $\frac{1}{8}$ -inch pipe can be slipped into the top of "B" and soldered. At the bottom of "B" is a small gauze which prevents any foreign substances from going into the carburetter.

**Connect** a lever leading to the foot or hand lever to connection "C."

**Press Flusher A** until the oil shoots out of the small hole on top of Chamber 1; then release A, pull lever C wide open while you turn the crank on your engine to start same.

If your igniter system is properly adjusted then your engine will start immediately.

While the engine is running adjust D until the Engine runs the best, holding C open while adjusting. Then you can set the small screw (air adjustment) so that when you release the lever C, the engine will keep on running as slow or fast as desired.

If then your engine does not run well, we would advise that you **put in a nipple and an ell in the bottom of the Carburetter.** This will cut down the suction noise, and will in nine cases out of ten help the running of the engine. If then you still get too much noise, we would advise that you connect a tin pipe (same diameter as the nipple) to the nipple and run up under the seat, This will give you an even temperature for the air supply and will deaden the suction noise entirely. This, however, is not absolutely necessary. It is sometimes advisable to reduce the air inlet with pipe fittings.

**It is necessary to have the lower level of gasoline supply just above the chamber I,** as the feed is by gravity.

These Carburetters are also used with the gasoline being below level of Carburetter. It is then necessary to force the gasoline to the Carburetter by air pressure.

Sometimes the Carburetter will not work satisfactorily, for the simple reason that some foreign substance has gotten into same. It is then advisable to examine the hole leading from chamber 1 to 2.

If the Carburetter drips very much, then the float is too heavy for the grade of gasoline which you are using. The float should then be taken out and as much metal as possible

## DISEASES OF A GASOLENE AUTOMOBILE

scraped off, reducing the weight of float. In case the float is too heavy, mail to A. L. Dyke, manufacturer, St. Louis, Mo., and a lighter float will be returned.

**After once attaching this carburetter and adjusting same, all that is necessary is to start your engine and operate lever "C" for various speeds. Full directions with each carburetter.**

It is advisable to press "A" down just before starting engine.

**After** the above connections are made open valve on gasolene tank, allowing oil to flow to "B."

**THE CARBURETTER IN USE.**—"Light" gasolene—that is, gasolene of high test by the Beume scale, should always be used. Slow-speed horizontal motors frequently require a fuel lighter than 68°, while multiple-cylinder high speed motors yield better results when 76° gasolene is used. In the absence of a Beume hydrometer, a handy method of testing the fuel and one that is fairly reliable, is to pour a little of the doubtful gasolene on the palm of the hand and move the hand rapidly back and forth. If the fuel evaporates at once, leaving the hand dry, it may be used with safety, but if it evaporates slowly and leaves a greasy deposit its use should be avoided.

**PRIMING THE CARBURETTER**—In starting the motor it is usually necessary to "prime" the carburetter by pressing down on a small pin, which nearly touches the float and projects upward through the float chamber, thus admitting the first charge of gasolene to the carburetter, but when the motor is running the gasolene is admitted to the carburetter automatically by the action of the float. Instead of a projecting float-pin, one type of carburetter is fitted with a rubber bulb, pressure on which forces the float down and accomplishes the same result.

The tendency is, perhaps, to overdo this initial "priming," in which case the motor will not start because the mixture is too rich. If this is thought to be the case, the electric current should be shut off, the motor "turned over" a few times, the spark switched on and, starting, tried again. This time the motor should start without trouble. (It is assumed that the sparking mechanism is in perfect working condition.) If the motor still refuses to start, it is possible that while turning the

## AND HOW TO CURE THEM.

motor over to exhaust the surplus gasolene the operator will go to the other extreme and that the carburetter will require additional "priming," but the previous experience will teach him not to do it to excess.

**REMEDYING CARBURETTER TROUBLES.**—Sometimes the motor will start readily enough, but dense smoke having a strong odor will issue from the muffler. This is generally an indication that the mixture is too rich, although infrequently it is due to an excess of lubricating oil in the cylinder. To correct the mixture, more air should be admitted to the carburetter by manipulating the small hand air lever—sometimes erroneously called the "gas lever"—which is usually mounted on the steering post or in some other convenient place.

A note of warning is in place against running a gasolene motor in a closed room while an improperly adjusted carburetter is yielding an excessively rich mixture. The exhaust gases in this case are poisonous, and they have a bad effect on the eyes, so plenty of ventilation should be assured.

If careful adjustment of the air lever does not correct the mixture, and it still remains too rich, the valve regulating the flow of gasolene to the mixing chamber of the carburetter should be adjusted to admit less of the fluid at each suction stroke. In case this does not give relief, and the carburetter seems to be constantly flooded, it is more than likely that the carburetter float is not properly fulfilling its function. This may be due to the float being punctured by repeated use of the float pin—the float is made of very thin metal—or it is possible that one of the soldered joints has opened. In either case the float will fill with gasolene and sink to the bottom of its chamber, thus opening the needle valve and preventing its closing. If the float is intact, it may be found that the needle valve stem is bent, or the valve has stuck, or that the presence of foreign matter prevents it closing. Repeated pressing on the priming pin should dislodge the dirt, but if it does not the cleaning nut at the bottom of the carburetter should be removed, allowing a considerable quantity of gasolene to flow through the float valve to the ground, so that the obstruction may be washed away. If examination proves that the float is punctured, or its needle valve bent or otherwise out of order, the repair should

## DISEASES OF A GASOLENE AUTOMOBILE

be left to an expert, unless it is of such a nature that it can be easily corrected by the novice. It is advisable to carry an extra float in the tool box, carefully wrapped up to protect it.

The primary air passage to the carburetter usually has a tube extending down to the muffler, so that warm air may be drawn in, rather than cold air. The outer end of this tube is flared or funnel-shaped and the mouth is covered with a fine wire gauze to prevent the admission of dust or other dirt. This gauze may get stopped up with mud or dust, thus choking the air passage, in which event the mixture will be found too rich to explode properly. An examination will quickly discover this trouble, and the gauze should be cleaned so that the carburetter may get its normal supply of air. This trouble is not infrequent, but the cause of it rarely occurs to the operator, and may be discovered only by accident after every effort to get a proper mixture has been unavailing. A little thought, however, will determine the difficulty, for if the mixture is too rich and the carburetter is not flooded, it is evident that something is interfering with the passage of air. If the gauze covering over the mouth of the air tube should get broken it should be replaced at once.

**MIXTURE NOT RICH ENOUGH**—Experience proves that more difficulty is occasioned by too weak a mixture than by too rich a gas. The symptoms of this trouble are insufficient power on hills and bad roads and the missing of explosions. The first thing to do, if regulating the air lever does not correct it, is to ascertain if the carburetter passages are all free from obstruction. These passages are not large, and they are more or less intricate. A partial stoppage of any one of them will result in a weak mixture. Removing the cleaning nut at the bottom of the carburetter and allowing a quantity of gasoline to escape, should clean the passages without trouble. Some carburetters are provided with other cleaning nuts, which close the ends of the various passages, and if these are removed it will be found that a wire can be forced through the passages, thus dislodging any obstruction.

Water in the carburetter is not an infrequent cause of its failure to work properly. All gasoline contains more or less water, which, being heavier than the more volatile liquid, set-



## AND HOW TO CURE THEM.

gles to the bottom of the supply tank and finds its way to the carburetter. If the cleaning nut is removed, the water—which will have collected in the lowest part of the carburetter—will pass out with the gasolene. Sometimes a quantity of water will collect on top of the carburetter filter, in the form of a film, interfering with the passage of the gasolene, in which case it will be necessary to remove the gauze for cleaning.

When filling the gasolene tank always use a strainer funnel; that is, a funnel fitted with a wire gauze filter. If one is not readily procurable, a tinsmith can easily solder a piece of fine copper wire gauze into an ordinary funnel - not down close to the tube opening, but about two-thirds of the way down from the top of the funnel, so that the filter will be of reasonable size. In the absence of a regular filtering funnel a piece of cloth may be fitted inside an ordinary funnel, preferably fine linen. Linen will absorb most of the water in the gasolene, and is particularly desirable on this account. Chamois skin has the same quality and makes an excellent filter. Never use the same funnel for filling both the water and gasolene tanks, but keep a filtering funnel exclusively for gasolene. The little extra trouble involved will be repaid many times during the season's driving.

Carburetters are usually fitted with several layers of wire filtering gauze of very fine mesh, located near the point where the gasolene from the supply tank enters the apparatus. The object of this gauze is two-fold—it not only filters the gasolene, but also prevents a possible "back fire" in the carburetter from communicating combustion to the gasolene tank. Although not a frequent occurrence, a "back fire" may be caused by a broken or inoperative inlet or exhaust valve permitting communication of flame to the gasolene tank if there is no such gauze. If foreign matter gets into the main supply tank—and this is bound to occur to a greater or less extent in time—it will find its way to the carburetter and the filtering gauze may get clogged—and cause a weakening of the mixture. This filtering gauze, in most carburetters, is easily removable, and should be taken out occasionally and cleaned.

In modern practice use is frequently made of a throttling device, operated either manually or by the action of a motor

## DISEASES OF A GASOLENE AUTOMOBILE

governor, and it is possible that the mechanism may get out of adjustment and cut off the gas mixture partially or altogether.

It may be found necessary to so regulate the spraying nozzle valve as to admit more fuel to the mixing chamber at each suction stroke, but this should not be a frequent requirement. Sometimes an examination will disclose a break in the gasolene supply tubes, allowing the gasolene to escape; or a coupling may work loose, preventing a proper gasolene supply; or one of the supply tubes may be stopped up. A valve is usually fitted to the gasolene supply tube immediately below the main tank, and this valve may be closed accidentally. In this case the motor will not start, or, if it should start owing to the presence of sufficient fuel in the carburetter, it will soon stop when that reserve has been exhausted. It is a good plan to inspect this valve each time when starting the motor, because much trouble may be caused by a little oversight in this direction. Manufacturers frequently recommend that this valve be closed after each use of the car, but if this is done it is the easiest thing in the world to forget to open it the next time the vehicle is to be used.

The quantity of the charge drawn into the cylinder of the motor at each suction stroke is determined, partially, by the speed of the engine, the suction increasing with the piston speed. From this fact it frequently develops that a mixture found to be correct at starting will require some change in the proportions of gas and air when the engine attains its normal speed.

**MISCELLANEOUS TROUBLES.**—If gasolene is allowed to stand for any length of time, even in apparently close receptacles, the more volatile part will pass off into the atmosphere. It is advisable, therefore, if a car has been idle for a long time, to remove the cleaning nut at the bottom of the carburetter and allow a quantity of gasolene to escape, so that the carburetter will receive a fresh supply from the tank.

The gasolene tank in American cars, especially in those of horizontal engine type, is usually of large area and has a flat bottom. When the supply of gasolene, therefore, is nearly exhausted it will collect in one end of the tank, depending upon the inclination of the car, so that in ascending or descending

## AND HOW TO CURE THEM.

hills or on a sloping road the flow of fuel into the tubes to the carburetter will be stopped. In this event the operator will be made aware of the depletion of the supply by the continual missing of explosions except when the machine is running on level ground, when the action will become regular again. When this peculiarity is noticed it is time to replenish the supply of gasolene.

If it should ever be noticed that the motor does not respond to the movement of the carburetter lever, an examination may show that the rods from the lever to the carburetter, which are usually very light, have become misplaced or bent, preventing the proper working of the air valve.

As a certain degree of warmth is necessary to secure a proper mixture trouble will sometimes be experienced in cold weather. It may become necessary to wrap the carburetter with a hot cloth to get the motor started, care being taken that the cloth does not cover or project over the air passages. A hot cloth may be wrapped around the gasolene supply pipe as well, thus heat the fuel sufficiently to assure good carburetting. These cloths should be removed, of course, as soon as the engine is running properly and before starting the car. Many operators wind the carburetters with asbestos wicking for protection in cold weather.

**SUMMARY.**—The following summary of carburetter troubles, the remedy for each of which is mentioned in the foregoing, may be of value for quick reference and for refreshing the memory:

Mixture too Rich.	}	Too much "priming."
		Too much gasolene.
		Punctured float.
		Float valve not working properly, owing to bent needle, or presence of foreign matter in valve seat.
		Primary air passage clogged or partially obstructed.
	{	Air valve not wide open.
Mixture too Weak.	}	Insufficient "priming."
		Carburetter passages clogged.
		Filtering gauze covered with dirt.
		Throttle valve out of adjustment.
		Insufficient flow of gasolene.
		Tank valve closed.
		Break in gasolene supply.
		Starting crank turned too slowly.
		Bad gasolene; originally, or from standing.
Water in gasolene.		
	{	Carburetter too cold.
	{	Gasolene supply exhausted.

## DISEASES OF A GASOLENE AUTOMOBILE

In this book an effort has been made to suggest all of the more probable carburetter troubles. Although the list looks rather formidable, it should not be forgotten that only one of the difficulties mentioned is likely to occur at a time, and perhaps none of them during a whole season. Only a little care and attention is needed to keep the carburetter in perfect working condition.

**CARBURETTER**—Sometimes trouble is caused by dust getting into the carburetter and thus preventing the proper supply of gas. This generally can be decided by the engine running fast and slowing down without any apparent cause for so doing. In the first place no gasoline should be put in the tank without first being strained, and we would strongly advise a piece of chamois leather being tied around the funnel, the gasoline readily running through the chamois, while if there is any water it will remain in the leather. To remove any dirt or water which may have gone into the carburetter, unscrew the milled cap immediately below the feed pipe from the tank. Take out the strainer and thoroughly clean same, previously turning off the gasoline by the pet cock. Before putting back the cap, turn on the gasoline to see that it flows readily, so as to make sure there is no stoppage in the supply pipe itself.

Care should be taken to see that the gauze wire on the air pipe to the carburetter is not choked up with dust, mud or oil, and should be kept clean. This will prevent a proper supply of air reaching the carburetter and cause too rich a mixture, resulting in dirty spark plugs. At the same time if the wire gauze should become broken, have same renewed at once, for if this is left open all kinds of foreign matter will be sucked into the carburetter and into the engine, and in case of grit getting into the engine it will clog up the valves and cause the engine to stop, and at the same time has a tendency to cut the walls of the cylinders. Should the engine give out bad odors through the muffler, the mixture is much too rich, and if this cannot be remedied by the adjustment of the lever to the carburetter, then it is up to the float being full of gasoline. This can easily be determined by pressing down the plunger in the carburettor, and if the float cannot be touched it has either stuck or sprung a leak, causing the gasoline to flow through nozzle too freely. Extra floats should be carried along.

## AND HOW TO CURE THEM.

**TOO MUCH** gasoline fed to the carburetter will choke it down so that when you attempt to speed engine up it will almost stop your engine.

**SOMETIMES** when you first flush your carburetter (give it gasoline by pressing needle on top of carburetter) and start your engine it is advisable to not speed up engine until the excess of gasoline has been consumed; about half a minute after starting motor generally suffices.

**A LEAKY FLOAT.**—In starting out one day for a drive the action of the engine was very irregular and the power very low. At last it was noticed the gasoline was constantly dripping from the carburetter overflow, and after a few more miles of running the stable was sought, where an investigation was held. The carburetter was taken apart and the float removed, when it was found to be about half full of gasoline, adding sufficient weight to it so that it did not rise and close its needle valve, but allowed gasoline to come into the float chamber all the time, thus flooding the carburetter continuously. The leak which existed in the float was quite hard to find, on account of its very small size. The only way in which it was located was to heat the float considerably and then search for the hole.

**WATER** in your gasoline will cause trouble. A small one-eighth draw cock should be at the bottom of every carburetter. Occasionally drain it.

**QUICK STARTING.**—The following little trick which I have found very useful may interest others. Whenever, in starting my motor, the carburetter balks and a lot of cranking is seemingly necessary, I saturate a rag with gasoline and hold it over the carburetter air intake. This positively allows the starting of the motor after the first compression stroke. I call the process giving the motor an anaesthetic. If anyone is in doubt as to the cause of the motor not starting easily, this procedure will show whether the difficulty is or is not in the carburetter.

The carburetter should be placed as close as possible to the motor, as the shorter the pipe the greater the partial vacuum

## DISEASES OF A GASOLENE AUTOMOBILE

produced in the carburetter by the suction stroke of the piston, and the greater the volume of mixture drawn into the cylinder. The trouble is undoubtedly due to the inlet pipe being of too great a length.

**CHEMICAL ACTION IN CARBURETTER.**—Upon examining the carburetter of my car I frequently find a slimy green deposit in the float chamber of sufficient density to clog the gasolene inlet to the chamber. What is this deposit and what is the cause of it?—N. A. S.

The slimy green deposit is arsenate of copper, formed by chemical action between the copper in the brass casting of the carburetter and natural impurities in the gasolene.

**TROUBLE WITH CARBURETTER.**—I have trouble in starting the motor of my gasolene car. It is equipped with a float-feed carburetter, with a fixed or permanent nozzle in the jet chamber which cannot in any way be adjusted. Sometimes I can get the motor to start by tickling the float, so as to allow an excess of gasolene in the mixing chamber, but most generally I have to prime the inlet valves of the motor with gasolene from an oil can before I can get the motor started. Can you suggest any remedy for this trouble or tell what is the probable cause of it?—C. H.

The trouble mentioned is one which is common to many makes of float feed carburetters, but is very easily remedied. The nozzle in the jet chamber is either too long or the float in the gasolene chamber too light. If the nozzle be of sufficient length to stand being cut down, this is the simplest remedy; if not, solder a small piece of brass or copper to the float. A little experimenting will be necessary to get the desired results.

**TO ALLOW THROTTLING.**—Benton Harbor, Mich.—Editor MOTOR AGE—The motor of my gasolene runabout has a throttle in the intake pipe, between the carburetter and the inlet valve. When I try to slow the motor down by means of the throttle, it invariably stops if the throttling is carried to a point which should reduce the motor speed the desired amount. Can you suggest any reason for this difficulty and also a remedy for it?—J. H.

If the gasolene needle valve of the carburetter is set to give

## AND HOW TO CURE THEM.

the correct quantity of gasolene when the throttle is open, the trouble must then lie in the fact that the air inlet of the carburetter is too large to produce a partial vacuum when the motor is throttled. A reducing bushing should be inserted in the air inlet, the proper size of which will be more or less a matter of experiment. If this plan does not give the desired results, attach a butter fly valve to the air inlet of the carburetter and so connect it to the throttle that it opens and closes in a corresponding manner. That is, when the throttle is open, the butter fly valve will also be open, and when the throttle is partially closed the butter fly valve will be in a corresponding position. The rod connecting the throttle lever to the lever of the butter fly valve should be made adjustable, so the relative position of the throttle and the butter fly valve may be varied.

**NOISE IN AIR INLET.**—I am greatly annoyed by the noise which the air inlet to the carburetter of my motor makes. If I close the air inlet, it makes the mixture too rich and slows down the motor, besides giving off a disagreeable odor from the exhaust outlet of the muffler. Is there any way of overcoming this trouble?—D. G.

Make a sleeve of coarse canvas, or get a circular lamp wick, such as is used in the Argand type of oil lamps, about nine inches long, and sew one end up and fasten the other end over the end of the air inlet to the carburetter. This will not only deaden the noise but prevent dust or dirt from getting in the carburetter.

**JET AND SPRAY CARBURETTERS.** What is the difference between a spray and a jet type of carburetter?—M. Y.

A spray type of carburetter delivers the gasolene in the form of a fine mist, while the jet type discharges the gasolene in the form of a small stream.

**STYLE OF CARBURETTER.**—Which is the more suitable for use with a 4-horse-power gasolene motor, a mixing valve or a float-feed carburetter?—H. W.

It depends largely upon the speed of the motor. A mixing valve is suitable for speeds up to 750 revolutions per minute, while a float-feed carburetter is better for speeds above this point.

## DISEASES OF A GASOLENE AUTOMOBILE

**VALVES.**— A valve in a very bad or pitted state causes very bad compression and the exhaust valve should be ground occasionally. After grinding the exhaust valve be sure that the stem has ample clearance between the exhaust valve lifter. It should

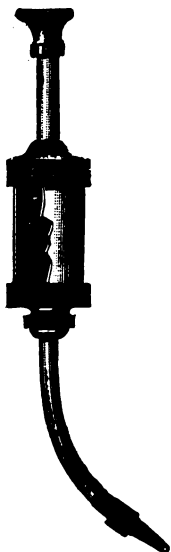

**Syringe** for injecting kerosene into Cylinder to clean off rust on pistons and also for cleaning bearings.

have not less than the thickness of one vibrator, otherwise when the valve becomes hot it will not seat properly, poor compression being the result. In grinding a valve there is no occasion to use a lot of force, and should be done lightly the valve being lifted from time to time so that should any foreign substance get into the emery it will not cut a ridge in the seat or the valve itself. After grinding the exhaust valve always wash out the valve seat with a little kerosene and be careful that none of the emery is allowed to get into the cylinder. A little cotton waste tied to a string and attached to the motor is a good preventive of this, string being the precautionary measure against cotton waste falling down into the cylinder. If the engine should start galloping or give a series of uneven explosions test out the springs by pressing them down with a screwdriver while the engine is running and if this makes any appreciable difference in the running of the engine it requires new exhaust valve be cleaned out, say every two months, to do away with any little filings, etc., which may have collected. Never clean out the engine with gasolene; use **kerosene**, same applies to the gears. Pet cocks are provided for so as to allow the emptying of the motor and gears. As regards the differential, it is hardly necessary to clean this out so often but it

should be examined to see that everything is properly adjusted. **THE DIFFERENTIAL** and hubs are all ball bearings and are easily adjusted. These should be nicely adjusted, so as not to have them too tight. Always have them on the loose side in preference.



## AND HOW TO CURE THEM.

A handy device used quite a good deal abroad is shown in illustration. It is simply a kerosene syringe for injecting the kerosene in irregular bearings, pockets, etc., where the ordinary can will not reach. The force or pressure also tends to clean the bearings.

**CLEARING OUT CYLINDERS.**—When an engine has been over-oiled and the plug is found to be badly sooted in consequence, it is desirable not only to clean the plug before replacing it, but also to rinse out the cylinder with some paraffin. With many foreign cars this can be done from the paraffin pump on the dashboard. In others which do not possess this convenience, it is often possible to pour some into the cylinder. If paraffin is not available, kerosene may be used. A few turns of the starting handle can then be given so as to spread the cleansing fluid over the interior of the cylinder and the job is done. See illustration of syringe on page 66.

**HOW TO GRIND** a valve: Strip the stem of its lock, nuts and spring, and remove the cap or plug over the valve pallet, lift it out and examine the seat. If it does not show a good,

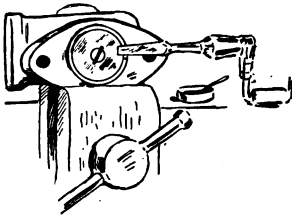

bright bearing all around it needs grinding, which is done as follows: Apply lubricating oil to the seat, then sprinkle on some flour of emery, No. 90 to begin with, use flour of emery at last, and drop valve into seat. The top is usually creased to receive a screw driver bit. Turn around and around for a time and then back

and forth in a semicircle, work it this way alternately for sometime; occasionally lift the valve from the seat, let it drop back and repeat the grinding.

Sometimes an hour may be spent grinding a valve. An absolutely **closed** seat must be attained.

**THE INLET VALVE SPRING**, if not properly adjusted, will either cause the valve to not seat properly or tight enough by being too weak, or if too tight will not allow the valve to open wide enough to take in a full charge.

## DISEASES OF A GASOLINE AUTOMOBILE

The stem in an inlet valve becomes worn sometimes and causes the valve to not seat even, and thereby opens the compression.

A few turns of the inlet valve sometimes make it seat properly.

**WEAK EXPLOSIONS** indicate leaky valves.

**A CONSTRICTED EXHAUST** passage may retain a higher degree of heat in the cylinder and thereby assist in maintaining an igniting heat on some projecting point in the combustion chamber. But there is a power significance to valves and their passage that should determine their size and areas.

Constricted valve passages are a decided hindrance to the development of power. The valve proportions should always be carefully figured from piston speed and cylinder area.

The receiving valve area should be such as to give the ingoing gases a speed of from 95 to 110 feet per second. The exhaust gases should leave the cylinder at from 75 to 85 feet per second, at atmospheric pressure.

The exhaust should be larger than the inlet valve, because at the moment of opening the exhaust valve there is a pressure of from 25 to 35 pounds in the cylinder to relieve, and consequently the rush of exhaust gases at the moment of release is away above 110 per second, and if it had to pass through a constricted valve passage it would maintain the initial high speed throughout the exhaust stroke of the piston, resulting in a piston pressure on the entire exhaust stroke.

The point, then, is to figure the exhaust passage of such proportions as to relieve the exhaust gases at an average speed throughout the exhaust stroke of not over 100 feet per second. I regret to say that it is common practice among manufacturers in this country to make the valves and their passages too small.

In a number of engines I had the privilege to examine, manufactured by different concerns, I found either a constricted cylinder port or valve area, or both.

It is the height of folly to have a good big cylinder port, and choke the passage with a "measly" little valve, or vice versa.

## AND HOW TO CURE THEM.

The passage should be of uniform area, and of ample capacity from the cylinder port to the end of the pipe.

The manufacturer who will not figure these valve areas carefully of sufficient capacity is cheating his engine out of a reputation and his customer out of power.

**TIMING THE VALVES.**—The movement of the valves should be timed to give the proper results. This is an important point for all gas engine operators to remember. The valve cams on a four-cycle engine are usually driven by the two to one gear fitted onto the crank shaft, and if for any reason the gears are taken apart and put together, even if only one cog out of place, it will throw the valves and sparking arrangement out of time.

Manufacturers usually mark a **tooth** or **cog** on one gear and its corresponding groove on the other with the same mark. These marked points should always meet, and the engine is then properly timed. You can, of course, easily understand how a cam and cam roller may become worn by constant use so as to throw the valve out of time. A worn condition means lost motion, which results in opening the valve too late and closing it too early.

You can test an engine to know if it is properly timed by turning the wheels over slowly and noticing at what point the valves open and close and where the igniting points separate.

The **receiving valve** should open at the beginning of the outward stroke and close at the end of the same stroke. The next inward stroke is the compression stroke, when all valves should be closed.

The **sparker points** should separate and make a spark just before the end of the compression stroke is reached. This is done to allow for the instant of time between the making of the spark and the resulting combustion. The force of combustion does not come instantaneous with the making of the spark. Therefore the compression stroke will have ended before the force of combustion really begins, and the piston just starting on its outward stroke receives the full expansive force of combustion.

If the spark were made just at the end of the compression stroke actual ignition or expansion would not occur until the

## DISEASES OF A GASOLENE AUTOMOBILE

piston had traveled probably a fourth of its outward stroke. This delayed combustion could not be as effective as if occurring at the very beginning of the working stroke.

The **exhaust valve** should open when about three-fourths of the working stroke is completed, so as to relieve the cylinder to something near atmospheric pressure at the end of the stroke. The exhaust valve should then remain open for the entire exhaust stroke, and should close just as the receiving valve is again opening.

Again I think it proper to refer to the question of lubricating the valve stems of the gas engine. The work an exhaust valve is designed to do makes lubricating impracticable. The heat passing through the exhaust valve will quickly destroy the lubricating qualities of any oil, and therefore it makes it useless.

It is therefore the custom of gas engine builders to make no provision for valve lubrication. They can be operated successfully without oil. Before starting a new engine squirt some kerosene oil on the stem and see that it moves freely.

**TESTING COMPRESSION.**—Poor compression is promptly evidenced by the motor running badly and producing an insufficiency of power. The prime causes for this unsatisfactory state of affairs is usually either badly-seated valves, worn piston rings, or defective joints. To test the compression, leave the compression tap or release closed, the valve-lifter down, or leave out of action whatever means are adopted by the makers of the motor for relieving compression for starting purposes. Take the starting handle and gently turn round the crankshaft until resistance is met with; continue pressure upon the handle and note the length of time the resistance is maintained and the amount of power necessary to overcome it. The longer the time of resistance, and the greater the strength required to overcome it, the better the compression and the more powerful the motor. The compression of each cylinder in a multi-cylinder motor may be tested by opening the compression taps, or by removing the sparking plugs in all cylinders except the one to be tested, and proceeding as above. The time and resistance of each cylinder should be as nearly equal as it is possible to make them.

## AND HOW TO CURE THEM.

**EXPLOSIVE ENGINE QUERIES.**—Binghamton, N. Y., October 13—Editor *Horseless Age*:—In assembling the gears for timing the exhaust what is considered good practice,—to have the exhaust valve begin to open at the beginning of the return stroke, or will better results be obtained by setting a little ahead or behind?

In igniting a duplex engine in which the explosions occur alternately, can satisfactory results be gotten with one coil and a device used to shunt the secondary current from one cylinder to the other?

On general principles, would not better igniting results be obtained by the use of a vibrator?

What cause can be assigned for the breaking down of the insulating material in plugs, outside of actual breakage?—DUDLEY T. GREENE.

[The exhaust valve should begin to open when the crank is in the dead centre position.

Yes, but a coil for each cylinder is a better safeguard against absolute breakdowns on the road and seems to be the preferred practice.

With a vibrator the certainty of ignition is probably somewhat increased, there being a series of sparks, but there is one more part to be kept in adjustment, and opinions as to the advisability of using a vibrator seem to be about evenly divided.

Accumulations of carbon and oil will cause surface leakage. — ED.]

## Water Circulation.

Any failure in the water circulation unless detected at once, will cause overheating, the results of which may prove very serious. For this reason a careful watch should be kept on the water gauge, and if this useful index is not fitted, the engine and pipe should be felt by the hand. Should the car begin to run sluggishly, the test tap should be opened, or some means found of finding out if the usual volume of water is circulating. In case of failure, the following are the points to look for defects:

**THE PUMP**—If the drive is by friction wheel, see that the wheel is not slipping. If it is, slightly tension the spring so as to make the contact just sufficient to overcome the vibration of the

## DISEASES OF A GASOLENE AUTOMOBILE

road. Over-tightening only brings a severe strain on the bearings, and does no good. If the leather of the wheel is greasy, carefully clean it and the part of the fly-wheel against which it bears with petrol, and then dress it with slaked lime. See that the spindle has not locked in its bearings for lack of lubrication.

If a chain-drive, the chain might break or come off, which is generally due to undue slackness. It should be adjusted until there is just perceptible sag. If the pump is gear driven, there is not so much danger of trouble.

In some cases the drive is by leather belt. It should be treated occasionally with castor oil, and the slackness taken up should slip become apparent.

The drive being right, the next point to make sure of is that the internal economy of the pump is in order.

The centrifugal and semi-rotary pumps are the two types most in use for motor cars. The first requires a high speed of about 2,000 revolutions and the latter about 300 to 400 revolutions per minute. As the centrifugal is merely a fan wheel revolving in an enclosed chamber, there is practically nothing to get out of order, and from this point of view it is better than the semi-rotary, but its high speed is very trying on the bearings, and it is these that cause trouble with this type of pump.

These bearings are usually ball bearings, and, if in proper order, the friction set up in them is very slight, but a chipped cone or broken ball will produce great heat, which is very likely not only to break up itself but the other bearings as well, on account of the unequal strain; therefore, ball bearings must have more attention paid to them than plain bearings. They should be often washed out, taken asunder, and examined, and well greased with a grease pump, and if any heat is noticeable they should not be run till the cause is ascertained.

Semi-rotary pumps, on account of their slow speed, are not likely to give much trouble in their bearings if kept well lubricated, but this type of pump has four valves, which, if trouble arises, are usually the cause. Any dirt or grit on the valves will prevent them closing. If a good washing out has no effect, remove the face of the pump, clean the inside thoroughly from dirt and grease, and see that the valves have a lift of about 1-8 inch off their seatings. The valves may be worn and

## AND HOW TO CURE THEM.

require reseating, or it may be necessary to fit new fibre or rubber washers. It is a great convenience to have a tap above and below the pump, so that if it has to be unshipped on the road, it will not be necessary to empty out all the water, but in such case care must be taken to open the taps before starting the engine.

A slight leakage of water is not of much consequence. If, however, the lead is bad, see that the grease cup is thoroughly full, and screw the top partially home. Also see that the packing nut gland is tight. If the packing wears, it will have to be replaced. Tow mixed with tallow makes the best packing.

In the semi-rotary style of pump, the trouble may arise through the throw being insufficient, except under favorable circumstances.

**THE PIPE AND CONNECTIONS.**—An air-lock in the pipes is exceedingly difficult to diagnose, in that it frequently only partially interferes with the water circulation. It is of much more common occurrence than most people imagine.

It is a good precaution, if there is an air tap in the radiators, to invariably open it when filling up with water, and also when the car is stationary. If the presence of an air-lock is suspected, stop up the overflow pipe by means of the hand or a large cork, and then flood the tank until the water comes out at the inlet pipe.

**It is necessary** to keep water circulating around the cylinder of a gasolene engine. A very satisfactory plan of cooling with use of a pump is called Thermo Syphon, or Gravity System. This plan is generally used on horizontal types of engines. The usual method is to connect from the bottom of the tank to the radiator; from the radiator to the bottom or lower cylinder connection, and from the top of the cylinder to a point about two-thirds up the tank. Placing the tank entirely above the top of the cylinder allows all the water to be used before refill-

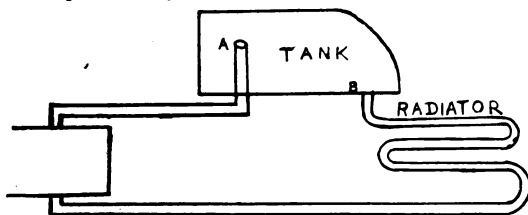

ing the tank, but in most cases the tank is located as described.

In this system the hot water goes through

tube A and following on the cold water forces the latter out and

## DISEASES OF A GASOLENE AUTOMOBILE

keeps it in circulation. See illustration "Thermo Syphon."

Where this is not possible such as with some types of

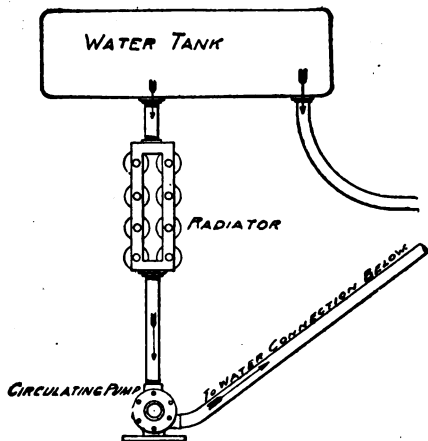

Forced Circulation.

vertical engines and multiple cylinder engines the Forced Circulation is used.

Illustration shows the pump which is generally connected to engine shaft by means of chain, belt or otherwise.

**A bursted water jacket, the result of freezing.**—No matter how much is said or written in the way of caution about draining the cylinder jacket and

water pipes, carelessness will prevail in some instances and a freeze up, bursting the cylinder jacket, will occur.

It is fortunate, however, that the cylinder itself is seldom injured by these freeze-ups. Usually only the outer casing bursts, and hence does not interfere with the successful running of the engine.

When the exhaust valve chamber is watered the same trouble will occur with it if it is not properly drained.

When a freeze-up occurs it results usually only in cracking the water casing and the remedy is to patch it and go ahead.

The patching is done as follows: Drain off all water, plug lower pipe connections, fill jacket with salammoniac solution (one pound to a gallon of water), let stand thirty minutes, drain and run engine five minutes to warm jacket. Stop engine, put solution back into jacket and repeat the process three or four times. If the crack is not too large you will thus form a **rust joint** that will never leak.

The pipes may get steam-bound also. In this case open the tap on the radiators, engine crown, or other portion of water



## AND HOW TO CURE THEM.

circulation; allow steam to blow out, and leave the tap open until water pumps freely from it.

If the overflow pipe is too short, it may allow the water to syphon out of the tank without the driver's knowledge, or a broken connection may have the same result.

Leaking or broken pipes can easily be mended temporarily by connecting the defective parts with a piece of rubber tubing, wired into position, and for this purpose tubing should always be carried.

**THE RADIATOR.**—Very often the radiators are at fault, being insufficient to cool the water. Grease, too, may get into the



Dyke Fin Type Radiator.

radiators from the pump and condense along the inside of them. The remedy for this is to take the radiators off, and connect them up with a steam pipe from a boiler for about two hours. If the radiators are exposed to mud, the gills may

get choked up, and the air is prevented from having free access. The mud should be carefully scraped out if possible.

**Insufficient Radiators.**—Unless the radiators and pump are very efficient, climbing long hills at a slow pace with a wind astern will cause overheating. In the case of air-cooled motors continuous hill climbing, in combination with a full supply of mixture, is very trying. If there are any symptoms of overheating, it is prudent to call a halt and let the engine cool. Opportunities of running free downhill should be taken full advantage of.

**WATER IN CRANK CHAMBER.**—Water in the crank chamber will emullify with the oil and cut the bearings. It may get in with the lubricating oil, and to prevent this the oil reservoir should be cleaned out when the oil at the bottom gets a whitish appearance. If any of the pipes running to the crank chamber or cylinders are unscrewed when the car is being hosed down water may penetrate in this way.

If this does not stop the leak take an iron plate, long enough to cover the crack, shape it to the cylinder, drill quarter inch holes along each edge about two inches apart, drill and thread

## DISEASES OF A GASOLENE AUTOMOBILE

holes into the cylinder wall to match, lay a piece of candle wick well saturated with white lead on the crack and bolt the plate tightly over it with one-quarter inch round head screws. When using this method it is best to chip a little crease along the crack to receive part of the wick.

**CLEAN THE PIPES.**—Once a month it is a good plan to wash out the pipes, water jacket and water tank with a strong solution of common soda or lye. Let the motor run a few minutes before emptying the solution, then empty the tank and pipes and repeat the operation with clean water. This process will tend to insure uniformly effective circulation of the water.

**ANTI-FREEZING SOLUTION.**—*Neutralization of Free Acid in Commercial Calcium Chloride.*—Editor HORSELESS AGE—A number of automobilists have complained that the use of calcium chloride corrodes the tanks, pipes,

etc. This differs from the results of my experiments on the action of this salt on the metals commonly used and from the practical results obtained by others, and must be due to the presence of free acid in some of the commercial calcium chloride. To neutralize the free acid it has been suggested that caustic soda or other alkali be added. This is open to two serious objections. If the acid were exactly neutralized, sodium chloride (common salt) would be formed and introduced into the solution in proportion to the amount of free acid present, which would be undesirable. If soda in excess were added, lime would be precipitated and sodium chloride introduced into the solution in proportion to the soda added. The rational neutralizer, to my mind, would be a handful or two of lime, slaked or unslaked. Lime is comparatively insoluble in water, and would combine directly with any free acid present, forming calcium chloride, slightly increasing the strength of the solution in proportion to the free acid present.

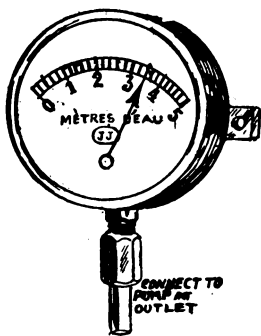

A water meter is generally connected to the pump by  $\frac{1}{8}$  pipe connection. As long as the water is circulating it will show the presence of same. Meter is placed on the dash.

## AND HOW TO CURE THEM.

Another Solution is Chloride of calcium, in the proportion of 2 pounds to a gallon of water makes a good non-freezing solution. Care should be taken not to use chloride of lime instead of chloride of calcium. Glycerine can also be used instead of chloride of calcium, but it has the disadvantage of decomposing at high temperatures; and it is also injurious to rubber hose.

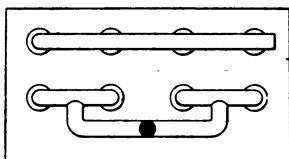

**The arrangement** of piping shown in the upper view in the drawing is a very poor form of connection to the inlet valve openings and is the cause of trouble.

The lower view in the drawing shows the correct method of piping to the inlet valve openings from a single carburetter, so that the distance the fuel must travel to reach each cylinder will be the same.

## Lubrication.

BY ALBERT L. CLOUGH—From HORSELESS AGE.—The subject of lubrication is rather an uninteresting one, and often seems to be dwelt upon unduly. Nevertheless its importance is such as to demand no apologies. Failure of proper lubrication is admittedly the most common cause of injury to automobile mechanisms, and it is especially to be noted that these injuries most often occur in the early use of a machine before the operator thoroughly understands the demand for oil existing in its different moving parts, or even understands what the parts themselves are, where located, and how supplied with lubricant. It has too often been the case that in the first or second trip with a new machine some damage has resulted from faulty lubrication, and it is certainly too bad to take chances with a new machine which may lead to permanent injury and a great deal of expense through failure to properly provide for its oiling. After a machine has been operated

## DISEASES OF A GASOLINE AUTOMOBILE

for some time, its lubrication becomes habitual with the owner, and there is very little chance of damage resulting under these circumstances.

A great many people are **receiving new machines** at this season of the year, and a great many of them are being shipped to the owners without competent demonstrators accompanying them. Sometimes the instructions for oiling are very meagre, and it seems to be a common fault in the literature received from the manufacturers to make the oiling operations appear very easy and unimportant, apparently with the idea of impressing the owner with the slight amount of care required by the machine.

It would be a wise precaution if upon the receipt of a new machine the owner should first become acquainted with every detail of the lubricating mechanism; not only with every part which can possibly require lubrication, but to become thoroughly familiar with its oil supply, to note its rate of feeding and not be contented with the mere fact that oil is supplied, but be sure that the oil actually reaches the point of use through the appropriate pipes or channels. Where the oil pursues a devious path in reaching the bearing, as in a crank shaft, one should be satisfied that the oil channels are clear and free.

### NECESSITY FOR PROPER LUBRICATION.

There are a great many different points of attention about an automobile, failure to attend to which will result only in inconvenience and not in damage and loss; but the matter of lubrication is one the neglect of which is sure to be serious. A case was observed recently of a machine of reputable make which had been nearly ruined by lack of lubrication. The crank shaft had been broken owing to its bearings having been allowed to run dry and heat excessively. The final bindings of these bearings and the unusual strains thus thrown upon the shaft, together with its very high temperature, caused its failure. When it gave way the connecting rod was bent almost beyond the hope of repair, one of the balance weights was broken and the hub of the fly wheel was cracked by the terrific jerk which took place when the engine finally stopped. The crank case was fortunately not broken. Some of the bushings of the

## AND HOW TO CURE THEM.

transmission gear shafts were badly worn from lack of lubrication, the roller bearings of the rear axle were both entirely ruined, having been allowed to run dry, and the clutch had been worn almost to its limit of adjustment through the same cause. To put this car into running condition will be a large expense, and it is all directly attributable to lack of lubrication.

### STUDY THE LUBRICATING SYSTEM.

It requires some self restraint to forego the pleasure of operating a newly received vehicle before looking it over mechanically, but this slight sacrifice is certainly warranted in the better understanding of the vehicle and its needs which will come from a careful inspection with the aid of a first-class mechanic, or, still better, an operator of the same make of vehicle. If one would surely avoid injury to the vehicle at the start, with its effect upon all its future operation, he certainly should look to the oiling mechanism before operating the carriage at all.

There is one thing which makes toward conscientious lubrication, and that is the provision of convenient

### FACILITIES FOR HANDLING AND STORING

oils and a good light to enable the operator to definitely ascertain whether his oil is going to the right point. Sometimes the difference between convenient oiling arrangements and inconvenient ones will be sufficient to determine whether the machine receives any oil at all, and possibly determine the fate of some part of its mechanism. It is good judgment to have lubricating oils kept in receptacles from which they can be pumped or drawn without the necessity of pouring from a heavy can. They are much more cleanly when kept in this manner and the cans provided with small drip pans. A stable may well be equipped with oil cans of the most convenient forms to reach the most inaccessible parts of the mechanism, as, in case oiling is made convenient, there is less liability of its being neglected.

### AN INCANDESCENT LAMP

on a flexible cord is almost necessary to examine the lubrication of concealed parts of the mechanism. A machine which is easily accessible in all its parts is likely to have a longer life than one otherwise constructed, on account of the greater lia-

## DISEASES OF A GASOLENE AUTOMOBILE

bility of its receiving proper lubrication. The lubrication of a machine in which the parts are crowded or which cannot be readily exposed to view is almost sure to be neglected, unless its owner is more conscientious than the average.

Probably the majority of machines are lubricated by means of sight feed gravity lubricators, and these require adjustment to pass the proper quantity of oil at the working temperature of the machine. The best time to adjust them is upon returning from a trip with the engine thoroughly warmed up. By placing an incandescent lamp behind the sight feeds, their action can be easily noted and regulated. The desirability of an oil which has every quality as a lubricant and still is not much altered in thickness by temperature changes is most apparent, as a correct set of a lubricator can be readily made with such a lubricant. Fortunately, cylinder oils having all the necessary good qualities in a satisfactory degree can be obtained.

### ONLY ONE QUALITY OF OIL.

It is a great convenience to be able to use one quality of oil for all the requirements of the machine, both for cylinder lubrication and the oiling of other moving parts. This practice is perhaps not scientific, but it is fairly successful where a good oil is chosen, primarily of such quality as to be successful in the cylinder. This should be found suitable for the gears of the transmission, for the clutches and for the main bearings. If one could have only one oil to carry on a tour it should certainly be a good cylinder oil of very high fire test and sufficient but not excessive body.

Vehicles which have gravity feed multiple oilers, even when provided with sight feeds, sometimes suffer as to their lubrication by the stopping up of the long and sometimes circuitous pipes which convey the oil from the magazine to the bearings. One should not take for granted that the bearing or other part is receiving lubrication simply because the oil appears at the sight feed. The force feed multiple mechanical oiler, as ordinarily constructed, is the most positive method in general use for oiling bearings, and as long as its mechanism is in operation, with a proper adjustment at the start, one may feel reasonably sure that the lubrication is being effected. Still, it is sometimes possible to have one or more of the flow pipes stop-

## AND HOW TO CURE THEM.

ped up and their bearing run dry, as the free pipes take care of all the oil which is forced by the mechanism.

It is the writer's experience that

### A HEAVY OIL

is the lubricant of most use about an automobile, but many may differ with this view. Its use upon the wearing surfaces of clutches is much to be preferred over that of a light lubricant, as is the case generally where heavy pressures are the rule. The use of an oil of this quality in crank case lubrication of enclosed gears is accepted. Axle and wheel bearings are very often packed in vaseline or a similar preparation, if they are of the ball or roller type. Some of the statements as to the length of time that bearings so lubricated will run without injury seem to be exaggerated, and too often they are inspected only after some damage has been done to the balls or rollers. It is ordinarily very inconvenient to lubricate these bearings, especially those of the front wheels, particularly when of the wood type. In many, if not all, of these wood wheels it is necessary to remove the entire wheel, after jacking the machine up, in order to supply the bearings with lubricant. It would seem as if there should be means provided for the lubrication without this apparently unnecessary trouble. Heavy cylinder oil acts very well on roller and ball bearings so far as the writer's experience goes.

### GEARS AND CHAINS.

Owners who are unfortunate enough to have exposed gears about their machines will find them a most difficult part to properly lubricate, and it is necessary to find some good lubricant which will not throw off on account of its being either too thin or too hard, and which always will keep a film between the teeth of the opposing gears. Many use graphite preparations with success, but dry graphite seems to be crowded away from the points of wear, and graphite mixed with heavy grease acts in about the same way. A vacuum grease somewhat thickened with cylinder oil, so as to be quite sticky and yet not thickened enough to be readily thrown off, appears to answer very well in a great many of cases.

The method of lubrication of chains is too generally known from experience with bicycles to require any mention, although

## DISEASES OF A GASOLENE AUTOMOBILE

almost every one has a way of his own. For chain lubrication graphite has certainly won a pre-eminent position.

### IN GENERAL,

it may be said that nothing should be taken for granted in the lubrication of an automobile. Everything should be done to make the work of lubrication as easy as possible by having every convenience at hand. Heavy oils are more valuable than thin machine oils, apparently owing to the high temperature attained by the whole machine. The plugs designed for the drawing off of the spent oil from crank cases should carefully be looked after to see that they cannot drop out while running. If an undue amount of oil drips from any particular point of the machine it may indicate that the supply is excessive, that means for retaining it are not proper, or that the oil is too thin. Thick oil on the whole gives little trouble from working out of bearings, especially when everything is hot. A great many "pointers" in regard to the lubrication of a machine are likely to be obtained when cleaning it. The "wiping off" of a machine is a duty which no one having the instincts of a mechanic will shirk, as the dust which an excess of oil on the outside surfaces of the wearing parts is constantly collecting proves very injurious to the mechanism.

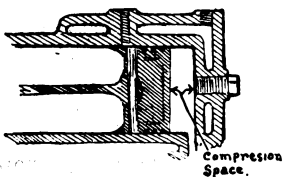
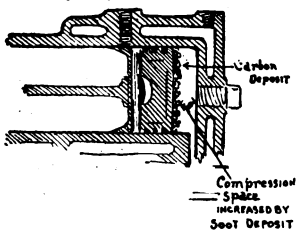

**POOR GRADE OF OIL** causes pounding. When it is exposed to the flame inside of the cylinder the poor grade of oil will burn and leave a carbon deposit on the end of the piston. This deposit increases the compression, that is, it makes less space between the end of piston and cylinder. Premature ignition causes pounding; if you advance your igniter too far you will notice that your engine will pound. In other words if the ignition occurs too early it causes pounding. Sometimes the carbon deposit will form in chunks on

end of the piston and after running a few minutes this soot



## AND HOW TO CURE THEM.

deposit will become red hot and will ignite the charge too early.

Too much stress cannot be applied on using good oil. There are only a few **good** grades of oil, which will really stand a fire test.

**IN THE CRANK CASE** a good high grade lubricating oil should be used. This should be a good grade as it will work its way back into the cylinder.

**On the gear box**, if separated from the engine, use a good lubricating oil.

**On bearings** use a good grease Albany or similar grease.

**On the chain** use graphite mixed with oil.

**Never allow** any graphite near your engine, it will get into your cylinder and foul your spark plug.

**Do not** fill your crank case too full of oil. The rule is to fill to the center of the pin when the latter is at its lowest position.

## Gasolene.

**BENZINE, NAPHTHA** and the kindred Hydro-carbons are products of crude mineral oil.

They are separated from the **crude oil** by a process of distillation. The process is very similar to that of generating steam from water.

By the application of heat, water raised to a temperature of 212 degrees Fahrenheit changes from a liquid to a gaseous state, called steam. This conversion is only temporary. If steam is confined and cooled to a certain point it will quickly return to its liquid state, water, by the process known as condensation.

**CRUDE MINERAL OIL** subjected to heat will give off in the form of vapor such products as Gasolene, Benzine, Naptha, etc. The degrees of heat at which these products are separated are comparatively low. Various degrees of heat will separate the distinct products. As a means of illustration, we will say that crude oil raised to the temperature of 110 degrees gives off vapor which when cooled will liquify into what is known as naptha; benzine at 125 degrees, and gasolene at 140 degrees. These degrees of temperature are not authentic—simply used to illustrate.

## DISEASES OF A GASOLENE AUTOMOBILE

After these lighter products are separated there yet remains the thick, oily liquid from which the various lubricating oils are prepared.

Paraffine oil is one of the principal products of crude oil, and the oily sediment which frequently accumulates in the bottom of the tank or can in which gasolene is confined is **paraffine oil**, which distills over in small quantity with the vapor of gasolene.

This oil might be finally separated from the gasolene by re-converting it into vapor several times and carrying it as such into a clean retort each time.

It should be remembered that gasolene that is practically free from paraffine can easily be adulterated by putting it into unclean containers. For instance, we take chemically pure gasolene and put it into a wooden barrel or tank, that previously contained oil, which has not been cleaned, it is easy to understand how the penetrating qualities of gasolene acting on the oil soaked staves will extract the oil particles and deposit them on the bottom of the vessel because of their lower specific gravity. In the same way other sediments than oil may get mixed with gasolene.

The comparatively low degree of heat necessary to produce gasolene from oil makes it a fluid that is very volatile and easily vaporized in our warm summer temperature and therefore difficult to confine.

The best kind of a tank to use in confining gasoline is made of well soldered, galvanized iron, fitted with a safety valve, which will allow escape of any gas that may accumulate to a certain pressure within the tank during warm weather.

A tank containing gasoline should never be so placed as to be exposed to the direct rays of the sun. This is done with many gasolene engine supply tanks and the result is an enormous waste of gasolene by direct vaporization, which loss is generally attributed to over consumption by the engine, very much to the detriment of its reputation.

If your supply tank is to be placed on top of the ground outside of the building it should be protected from the heat of the sun by putting a small building over it.

Storing gasolene in a wooden barrel is not economy by any

## AND HOW TO CURE THEM.

means. The wood is porous enough to allow considerable loss by vaporization.

When gasolene is exposed to air that is above the freezing point it gives off a vapor of gas which mixes or blends with the atmosphere, and if exposed long enough the quantity so exposed will all disappear or pass off into the air in the form of vapor, leaving only the paraffine residue or other sediment.

Several manufacturers of gasolene advise me that common stove gasolene is especially purified and does not originally contain any residue.

It would therefore appear that stove gasolene, which is ordinarily supposed to test about 74 degrees, is the quality best adapted for use in the gasolene engine, although the writer has knowledge of engines running successfully on gasolene testing anywhere from 60 degrees to 88 degrees.

**Distillate**, which might be called a low grade of gasolene, and which we are advised tests about 55 degrees, is successfully used to operate the majority of gas engines in California.

Much of the **residue** or oily substance which accumulates in the bottom of a gasolene tank is, in my opinion, due to the use of unclean barrels or tanks in which it is confined for storage or shipping purposes.

Another method of getting rid of this oily substance is to regard it as so much "dirt" and occasionally pour off all the gasolene and clean the container thoroughly from all sediment.

Gasolene engines often refuse to operate successfully on account of this sediment blockading some part of the supply passage between the tank and the engine.

Unfortunately the consumer of gasolene occupies the same position in the purchase of gasolene as the consumer of milk does in its purchase. They both buy "dirt." The only difference is that the latter after buying it is expected to digest it as well.

**IN CASE OF FIRE DUE TO GASOLENE**, use fine earth, flour or sand on top of the burning liquid. Never use water; it will only serve to float the gasolene and consequently spread the flame.

## DISEASES OF A GASOLENE AUTOMOBILE

### DEVICE FOR TESTING

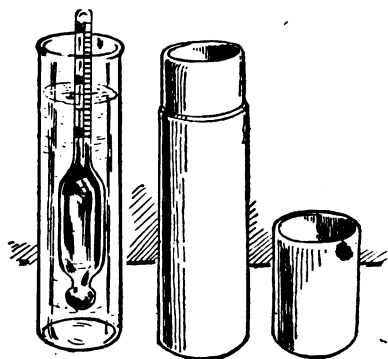

Gasolene is shown with illustration to the left. It is called a Pocket Hydrometer. Fill the glass jar half full or more with gasolene, put in the Hydrometer. The figure on level with the gasolene will indicate the gravity.

Gasolene is tested with the Baume hydrometer, which reads correctly at 60° Fahr. When the temperature is above 60°

one point must be deducted from the reading of the hydrometer for every 7½° of difference in temperature, and if the temperature of the gasolene tested is below 60° one point must be added to the reading of the hydrometer for every 7½° below 60. Your gasolene should test 68 to 72.

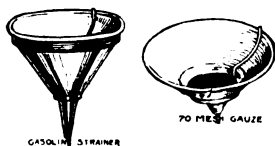

Fig.—shows a Funnel with 70 mesh gauze in it. This is something well worth using, as it keeps water and particles of grit from entering your tank.

Don't fill your gasolene tank too

full, remember it needs some air on top.

If you have a vent hole in the top of gasolene tank be careful that water does not run into it when your machine is washed.

A vent tube soldered to inside of funnel will keep it from overflowing the cup.

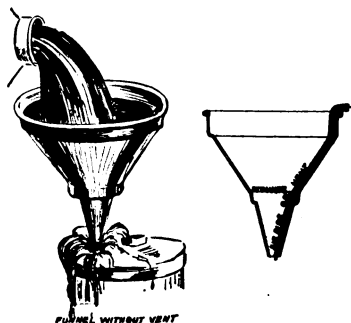

## AND HOW TO CURE THEM.

**WRONG GASOLENE.**—Is it not possible for users of gasolene automobiles to make a concerted effort to persuade local dealers or repair shops to carry a standard or reliable grade of gasolene for automobile use! For some time my motor was continually misfiring and working badly. I tried everything I could think of, but to no avail—ground the valves, put in new batteries, etc. I then compared notes with other users of cars and found they have the same trouble. We jointly purchased a supply of gasolene of a specific gravity of 0.72, and secured good working results. The gasolene I had been getting was found on testing to have a specific gravity of only 0.64.

**FUEL QUERIES.**—Kindly tell me what is the difference between 76° and 88° gasolene, and which is the best for a steam carriage?

Is there not an oil burner which atomizes the oil? If so, why is it not in more common use? I understand that the danger of carbon deposits is the reason which at present keeps most manufacturers from using the heavier oils. In using the oil in the form of a spray, it seems to me there would be no danger of carbon being deposited around the openings.

The difference between 76° and 88° gasolene is that the latter is much more volatile, and in consequence much more dangerous. In fact, it can hardly be recommended for use for this very reason, except, perhaps, during periods of extremely low temperature. The higher grade gasolene contains less carbon, and is therefore less likely to give trouble from deposits; but with the burner properly constructed the 76° should not give any bother in this respect.

Spraying oil burners are used on locomotives and in stationary plants, but never on automobiles, owing to the noise which accompanies their operation, and also to the fact that they are too cumbersome.

**EXTINGUISHING GASOLENE FIRE.**—No doubt a number have experienced considerable damage from fire, caused by leaky gasolene pipes on steam automobile and would like to know if there are any chemicals which can be used to put out such a fire. Water is an exceedingly dangerous proposition to use and it is not always possible to get at the fire to smother it with wet rags or waste.

## DISEASES OF A GASOLENE AUTOMOBILE

A dry powder can be used for this purpose which will extinguish the fire in a few seconds. It is made as follows: Common salt, 15 parts; sal-ammoniac, 15 parts; bi-carbonate of soda, 20 parts. The ingredients should be thoroughly mixed together and passed through a fine mesh sieve to secure a homogeneous mixture.

**If by any mishap**, a tank of gasolene takes fire at a small outlet, run to the tank and not away from it, and either blow or pat the flame out. Never put water on burning gasolene or oil, for the oil will float on top of the water and the flames spread so much more rapidly. Throw fine earth, sand or flour on top of the burning liquid. Flour is best. The best fire extinguisher for a fire of this sort in a room that may be closed is ammonia. Several gallons of ammonia, thrown in the room with such force as to break the bottles which contain it, will soon smother the strongest fire if the room be kept closed. Very often, simply striking the opening from which the flame is issuing, with the palm of the hand will put out the fire.

**ECONOMY OF GASOLENE.**—Speed has considerable influence over fuel consumption, especially in driving the engine empty. Take, for instance, an engine of four horse power, run it empty at a speed of, say, 250 revolutions per minute and notice its fuel requirements at that speed, then increase the speed to 500 revolutions per minute and you practically double the fuel consumption running the engine alone.

It is not always practical for a manufacturer to guarantee fuel consumption. I should say it is seldom, if ever, practical to do so without exacting from the purchaser conditions and requirements that would make him feel that the engine itself is not practical. In general the average fuel consumption may easily be kept down to the quantity above mentioned, although many conditions may arise to change the amount required.

It is not always the fault of the manufacturer if the fuel consumption overruns the estimate. It is more often the fault of the engineer in my opinion.

I should advise for economical fuel consumption:

First—To keep jacket water at 160 degrees Fahrenheit.

Second—To run engine at a medium speed.

## AND HOW TO CURE THEM.

Third—To use a good standard fuel.

Fourth—To see that every charge the engine takes is exploded, for which a proper mixture and a good spark or hot tube are necessary.

Fifth—The admission valve should close properly between charges, so as not to allow a continuous flow of fuel into the engine.

Sixth—Never throttle the fuel so closely that the engine cannot get a full charge every time it needs it.

Seventh—Be sure that there is no leak in the supply or overflow pipes where fuel can escape.

Eighth—When gasolene is used be sure that there is no leak in the supply tank.

With these precautions one will use only so much as will be required by the engine to handle its load.

**FUEL CONSUMPTION** of an engine is always a legitimate question, and one of grave importance to the purchaser as well as to the manufacturer.

Ordinarily about one and two-tenths pints (1 2-10) of gasolene, or about twenty per horse power per hour under full load, will cover the fuel consumption. That is, when the gases named are of standard quality and the water comes from the water jacket at a temperature of about 160 degrees Fahrenheit.

The temperature of the water in the chamber around the cylinder has very much to do with fuel consumption.

If water is forced around the cylinder so as to keep it cold, the heat from the explosions or combustion is cooled down so quickly by radiation that the expansive force is materially reduced, and consequently less power from the same charge.

The object of the water is not to keep the cylinder cold, but simply cool enough so as to prevent the lubricating oil from burning. The hotter the cylinder with effective lubrication the more power the engine will develop.

It should also be remembered that an engine is the most economical in fuel.

All frictional parts should be regularly lubricated. But the wrist pin and cylinder need to be especially looked after. The oil cups supplying these parts should be noticed often during a day's run to make sure that the oil is supplied and properly distributed.

## DISEASES OF A GASOLENE AUTOMOBILE

Insufficient lubrication of the cylinder is often indicated by a peculiar blowing, barking noise in the cylinder at each impulse. It is due usually to a dry piston allowing the force of combustion to pass the rings. It can often be overcome by adjusting the lubricator for a freer oil supply without stopping the engine.

After running a cylinder dry, at the first opportunity the piston should be taken out, and the rings, their seats and the entire piston thoroughly cleaned. At the same time the cylinder and combustion chamber should be examined with a lighted candle and cleaned from chunks of burnt lubricating oil and deposits of carbon in the form of soot. This is also a good time to clean the valves and valve ports as well as the igniting apparatus.

Before the piston is returned to the cylinder it should be lubricated with oil. A good engineer will seldom have this to do, because he will see to it that his cylinder is lubricated.

The wrist should run cool. If it does not it indicates that lubrication is at fault or that it is not properly adjusted.

**MORE PICRIC ACID QUERIES.**—Alameda, Cal.—Editor *MOTOR AGE*—I noticed in *MOTOR AGE* of May 7, a comment on the use of picric acid in gasoline. How much picric acid is used per gallon of gasoline and for what purpose is it used? In what manner does it increase the power of a motor?—H. M. P.

About 3-10 of a pound of picric acid is required per gallon of gasoline. The picric-gasoline solution increases the power of the motor by increasing the intensity of the initial explosive force of the compressed charge in the cylinder after ignition.

Toronto, Can.—Editor *MOTOR AGE*—In a recent issue of *MOTOR AGE* I saw a letter from a correspondent, giving his experience with mixing picric acid in gasoline for motor cycle use. I would like to know the per cent of picric acid to mix with gasoline and the manner in which it is done.—N. B. E.

Gasoline will absorb about 5 per cent of its weight of picric acid. The gasoline should be occasionally agitated to insure a thorough absorption of the picric acid and allowed to remain for 2 days before using, when it should be carefully strained through three or four thicknesses of fine linen.

Peabody, Mass.—Editor *MOTOR AGE*—Will you inform me how much picric acid per gallon of gasoline should be used?



## AND HOW TO CURE THEM.

Is picric acid explosive in itself and what precautions should be used in handling it? What increase of power will picric acid give when used in 76 test gasolene? Does the acid mix readily with the gasolene or will the gasolene have to be agitated to cause the acid to mix properly?—C. E. G.

About 3-10 of a pound of picric acid is required for a gallon of gasolene. Picric acid is not explosive in its normal state and may be handled without any danger. An increase in efficiency of about 30 per cent is claimed for the picric-gasolene mixture, but it will probably in ordinary use be about 20 per cent.

New York City, N. Y.—Editor MOTOR AGE—Having read all the articles in MOTOR AGE about picric acid, I do not find any data relating to the quantity that should be used in the gasolene. As I have always understood that picric acid is dangerously explosive, is there any danger of a cylinder head blowing off or of personal injury?—W. R. W.

Gasolene will absorb or take up about 5 per cent of its weight of picric acid, but the addition of a small quantity of kerosene to the gasolene, will enable the gasolene to absorb about 10 per cent of picric acid. Picric acid is only dangerous when used or when in a highly compressed state or mixed with other chemicals. There is no danger with the use of picric acid, of cylinder heads blowing off, or of personal injury.

**PICRIC ACID IN GASOLENE.**—Waltham, Mass.—Editor *Motor Age*—I recently tried the experiment of using picric acid in gasolene as described in *Motor Age*. After following the directions and carefully straining the gasolene, I put it in the tank of my motor-bicycle. The motor fired on the first turn of the pedals, and I was at once convinced that the power of the motor was increased, as the noise from the exhaust, due to the explosions, was nearly twice as loud as before. I immediately started out to try the stiff hill which I never climbed before without pedaling. The machine took me up the hill in great style with my feet off the pedals all the way up. I was so pleased with the results that I ran until my gasolene tank was almost empty, and then had to get back home on "common gasolene," and the difference was surprising. I used up all the "picric-gasolene" without a single misfire or any signs of the spark-plug sooting.—A. C. H.

## DISEASES OF A GASOLENE AUTOMOBILE

**USE OF PICRIC ACID.**—Newburg, N. Y.—Editor *Motor Age*—Being an interested reader of *Motor Age*, I would like to make an inquiry about picric acid. What is the proper amount to use per gallon of gasolene?—C. A.

About 3-10 of a pound of picric acid should be used in each gallon of gasolene. Allow the mixture to stand about two days before using, agitating occasionally during this time; then strain through two or three thicknesses of fine muslin before using.

**EFFECT OF PICRIC ACID IN FUEL.**—Des Moines, Iowa.—Editor *Motor Age*—Is picric acid dangerous to handle, and will the increased force or pressure produced, in any way injure the motor if the acid is used in gasolene in the manner recently described in *Motor Age*? Would there be any danger of explosion or detonation other than in the motor cylinder if the acid were subjected to concussion?—W. H.

Nearly all gasolene motors are built sufficiently strong to withstand the increase of pressure produced by the introduction of picric acid in the gasolene. The explosive force of picric acid is very much over-rated as an explosive agent. If thrown upon a red hot plate of iron, it simply burns with a smoky flame and striking a quantity of it upon an iron anvil will not explode it. There are certain combinations of picric acid with other chemicals, known as picrates, which are violently explosive if subject to detonation.

**MOTOR STARTING**—The first and really the most important point about starting the motor of a gasolene automobile is to ascertain if the cock underneath the gasolene tank is open. The neglect of this little precaution has caused the display of more bad temper, profanity and anxiety of mind than any other minor detail, except that of forgetting to switch on the electricity. It is to be presumed that the tank has been previously filled with gasolene.

Next tickle the carburetter to see if the gasolene flows from the tank properly, then give the motor one or two turns by means of the starting crank and with the compression release cocks open. If a mechanical feed or splash lubrication is used, there will be no necessity to look after the oil, but if a gravity oil feed is used, always turn on the oil before starting the motor;

## AND HOW TO CURE THEM.

it is extremely liable to be forgotten afterward. Then close the compression release cocks, switch on the electricity and one or two sharp turns should generally suffice to start the motor.

If the motor fails to start, first examine the inlet valve, if of the suction type, to see that it is not stuck to its seat, then the cam or commutator and contact maker of the ignition mechanism, to see that it is clean and free from grease or dirt. Last of all, if these points are all right, test the batteries, and be sure to carry a pocket ammeter for this purpose. In seven cases out of ten, failure of the motor to start is due to weak or exhausted batteries. Another point of importance in connection with the starting of the motor is to ascertain that the ignition mechanism is retarded before cranking the motor. Many a sprained wrist and not a few cases of broken heads or arms have been caused by the neglect of this simple precaution. It is a good plan to have the ignition control spring actuated so that in its normal position it is always retarded. Many cars are equipped with some device of this kind to prevent mishaps.

### **TO STOP.**—Shut off switch.

Close all oil cups.

Shut off gasoline if there is no float in your carburetter.

If in the winter and your machine will be in a freezy place drain your water.

Wipe engine clean, and see that it is ready for next run.

While cleaning engine examine all nuts and all points of adjustment.

Note condition of journals and bearings, if hot locate the cause of heating.

### **THINGS YOU SHOULD DO.**—See that your machine has a drain cock so that your water can be drained in the winter.

Always use the very best of cylinder oil in your cylinder, and a good lubricating oil in your crank case.

Learn how to adjust tremblers or wipe contacts, also trembling coils. To attain that knowledge, disarrange a motor and readjust it.

Learn how to set the timing gear correctly.

Learn how to trace and remedy loss of compression in the engine.

## DISEASES OF A GASOLENE AUTOMOBILE

Buy a densimeter, and understand the testing of the quality of gasolene.

Understand how to grind in the valves, also how to fit a new piston ring.

Learn how to treat a bearing or piston which has tightened.

Always throw your clutch in gradually, also throttle and spark advance.

After putting in a new packing in head or inlet valve and run your engine about two or three hours, tighten up the nuts again.

**Clean** all working parts often.

Never clean engine with gasolene; use kerosene.

**Kerosene** injected into the cylinder through spark hole and allowed to remain for a night will take off deposit of soot on end of piston; it should then be blown out through relief cock.

For the information of prospective buyers who must care for their own carriage I will say that it will be necessary to spend at least half an hour a day in the cleaning and oiling and general looking over. One quarter of an hour a day will often be sufficient, but, of course, occasions will sometimes arise where considerable more time must be spent for unusual mishaps. For the every day routine of taking care of an automobile I think half an hour a day is a fair estimate. Even if I have to spend one or two hours a day occasionally in mending tires, putting in new spokes or stopping leaks in gas or water tanks, I find my work is done so much easier that I do not get so weary as riding all day after a horse, and so much quicker that I find much more time for recreation and study than when I must depend on the horse.

**Many** owners of motor-cars fail to recognize the fact that their cars depreciate very rapidly in value by not being properly cleaned. The mud is allowed to dry on the paint and leave spots, instead of being washed off immediately the vehicle has returned to the garage. The motor becomes coated with grease and dust, and the entire vehicle rapidly puts on a dirty and second-hand appearance. On the other hand, there are cars which, after running thousands of miles, look almost as well as they did the day they were turned out from the factory.

## AND HOW TO CURE THEM.

To remove dust from the paintwork a large common painter's brush, is, remarks a writer in the "Automobile Magazine," as good as anything; but in muddy weather a soft sponge with plenty of water should be used. The sponge should be plunged frequently into the water and "dabbed" on the mud; do not attempt to wipe it off, as this will scratch the varnish. When every vestige of dust or mud has been removed the car may be wiped down with a soft chamois leather. Not even the brush, sponge or leather should touch any greasy part, or it will spoil the gloss of the varnish. Separate cloths or leathers should be used for the motor and the gearing, these parts being finished last, and care being taken that no grit or dust be wiped into the bearings. It is needless to add that all lubricators, tanks, etc., should be closed during cleaning operations. After having removed all the dirt and water from the car, wipe the bright parts with a rag having a little vaseline on it, and give the chains a coating of tallow and blacklead, which can be kept ready mixed, and applied with a brush like that used for cleaning.

Examine your steering gear frequently.

Examine your connection between carburetter and inlet valve. This sometimes gets loose and allows air to enter and does not give the right mixture.

1. See that there is plenty of water and gasolene in your tanks.
2. Clean the engine and all the wearing parts thoroughly.
3. Oil every part where there is any friction, **except valve stems and sparkers shafts.**
4. Open relief cock so as to relieve the compression.
5. Switch in battery current.
6. Flush the carburetter by pressing the float down (if it is provided with one) being careful not to give it too much oil.
7. Turn the fly wheel of the engine until it gets an impulse. After the engine is started close the relief cock.

In case the muffler smokes considerably it is proof that engine is getting too much gasolene and before throwing on the power the engine must be allowed to run a few minutes until the surplus of gasolene is consumed.

## DISEASES OF A GASOLENE AUTOMOBILE

Sometimes the smoke comes from there being too much oil on the base or crank case of the engine. **Smoke** means either too much gasolene or too much lubricating oil.

8. Start oil from lubricating cup on cylinder. Twenty drops per minute while engine is new, less will do later on. The cylinder is the most important thing to be kept oiled. Don't oil any part of machine too much.

When oil and grease cups are filled and all bearing parts that are liable to wear are oiled, the **valve stems** should be tried by lifting the valve pallet from its seat a number of times after squirting some kerosene oil on the stem from a squirt can. These stems should be frequently examined and kerosene oil used only occasionally to keep them clean. Never use ordinary lubricating oil on them. The heat simply burns it and leaves a gummy deposit on the stem which interferes with the free movement of the valve.

See that your water is in circulation.

You have no doubt heard persons say that they have to turn their engine for half an hour or more before they can get it going. If such persons knew that they are simply proclaiming their astounding lack of judgment they would not be telling it.

But, you say, if the engine fails to ignite its first, its second and its third charges, is it not policy to keep turning the wheel until it does ignite? If neither of the first three or four charges are ignited the cause of non-ignition will not be removed by turning the wheel and will probably be getting worse the longer you turn, and the fellow who does not know what else to do but turn ought to be compelled to turn vigorously until his tongue hangs out of his mouth to the length of a full grown lead pencil. If such exertion doesn't start his thinker his case is probably hopeless.

If an engine doesn't ignite its first charges there is a cause for it, and no amount of turning will locate it, but a little common sense thinking will not only locate but remove the cause, and the engine will do its own turning after the first two or four revolutions.

You would like to know why I say four. If common sense will do it, after allowing one revolution to admit the charge

## AND HOW TO CURE THEM.

and gain the momentum, why not always start or ignite the second revolution? There is no such thing as absolute perfection even in common sense, but four, and occasionally six, revolutions for ignition may come within the bounds of practical perfection. However, I know of many gas engine operators who seldom turn the wheel more than the second time.

The engineer who knows his lesson well will know that there are many improper adjustments and irregularities that will cause failure of ignition on the first turn and will avoid them, and as they are of sufficient importance to require special attention we had better finish starting the engine in a normal condition and take this subject up later.

**TURNING OVER COMPRESSION POINT.**—Nearly all engines are provided either with a relief valve or a shifting cam or lever, which makes a relief out of the exhaust valve. By means of these valves only the latter part of the compression stroke serves the purpose, in as much as the former part is relieved by an open valve. This allows sufficient compression to start with and makes resistance at this point barely perceptible in turning.

**OBSTINATE STARTING.**—Defective ignition is one of the principal causes, and you have already been told the remedy. But **slow vaporization** of gasolene in cold weather, **overcharging the ingoing air** with gas or gasolene when turning an engine over by hand, and **water in the cylinder** when trying to start are causes as frequently met with as Defective Ignition.

**SOME OTHER TROUBLES OF NON-STARTING.**—**Lever**s which shift the igniter may have become dearranged and spark does not occur at right time.

**AIR REGULATOR** not properly adjusted. May not get enough gasolene.

**PROBABLY** the last time you had your crank case open you dearranged the gears which operate the igniter and the contact does not come in the right place.

**SOOTY** spark plugs cause nine-tenths of the non-starting troubles.

**IF NOT** getting gasolene, by holding your hand over the air opening while engine is cranked it may draw in a good charge.

## DISEASES OF A GASOLENE AUTOMOBILE

**POOR** water circulation will cause heating to such an extent that the motor will not get up to speed.

**A SPARK GAP** helps obstinate starting wonderfully.

**IF** your engine stops and you attempt to crank it and it turns easy without compression it is likely due to the **inlet** or **exhaust** valve gummed or stuck up; never oil either of these.

**WATER** in the carburetter will cause trouble and should be drained.

You can facilitate vaporization of gasoline in cold weather for starting purposes by previously heating some point of the air inlet pipe, which serves to warm the air as it enters, which in turn vaporizes the gasoline better than cold air.

**LOOKING FOR TROUBLE AND LOCATING IT.**—Many Causes for Trouble—Read Them.—Don't conclude that a **thump**, **pound** or **thud** about an engine is always due to some trouble in the cylinder. Look for such causes as the following:

1. Pre-ignition (premature firing).
2. Badly worn or broken piston rings.
3. The explosive force escaping by the piston.
4. Improper seating of a valve.
5. A badly worn piston.
6. Piston striking some projecting point or foreign body in combustion chamber.
7. A loose cross-head bearing.
8. A loose crank or burnt bearing.
9. A loose journal box cap or nut.
10. A broken spoke, hub or rim in fly wheel, etc.
11. A fly wheel loose in shaft.

The sound produced by pre-ignition may be described as a deep, **heavy** pound.

Frequently using a poor grade of oil will cause pre-ignition; the carbon from the oil will deposit on the end of the piston in cakes and lumps, and will not only increase the compression but will get hot after running a short distance and will ignite the charge too early, and thereby produce the same effect as shifting the igniter forward too quick. If this is the cause the pounding will cease as soon as the combustion chamber is cleared of the carbon deposit.



## AND HOW TO CURE THEM.

Pre-ignition can be tested by throwing off the igniting current. If the engine continues to fire its own charge and runs along pounding, it is good evidence that the pound is due to pre-ignition. If, however, it ceases to fire the charges the instant the igniting current is cut off, pre-ignition caused by projecting point or carbon deposit may be excluded. If, however, the pounding keeps up until the engine stops, a tight piston is probably the cause of the trouble.

I have noticed sometimes in shutting off the current from a pounding engine and noticed it stop dead sooner than you would expect it to. And when endeavoring to turn the fly wheel over by hand the piston stuck tight in the cylinder; a few moments' rest, allowing it to cool, will loosen up the piston.

If a piston is made to fit the cylinder too snugly it will usually result in pounding when put under a heavy load.

If pre-ignition is the cause the pounding will cease as soon as the combustion chamber is cleared of the carbon deposit, the projecting point causing the firing is removed, the time of the spark set later or the flame on the tube elevated.

If the cylinder rings allow the explosion to pass, making a barking noise, they should be either replaced by new ones that are well fit into their grooves and also to the cylinder, or the old ones should be dressed with a fine file on their surface, so as to bear at all points of their circumference on the cylinder wall.

If the knock is in the crosshead it may be relieved by tightening up the bearing. Care must be exercised lest you get it too tight, which will make it knock more than ever.

If the knock is in the wrist it is best to take it up little at a time. A loose fly wheel must never be allowed to run until it is thoroughly keyed to the shaft and perfectly tightened.

I might add that pre-ignition is liable to cause undue expansion of the piston and cause it to stick in the cylinder. In such instances it is not proper to dress the piston until pre-ignition is corrected. A piston that sticks when pre-ignition occurs may run all right when pre-ignition ceases. The cause of this undue expansion of the piston from pre-ignition is the extreme heat the piston encounters.

## DISEASES OF A GASOLENE AUTOMOBILE

I recently had a most peculiar experience with my gasoline car. It has a horizontal single-cylinder motor, and up to the time of the incident had never given a moment's trouble, beyond the usual cares incidental to fouled spark plugs, poor gasoline and exhausted batteries.

The car was running on the fast speed on a level stretch of well macadamized road, when all at once a sudden pounding, or rather knocking was heard in the motor. The car was stopped and all bearings that were accessible were thoroughly examined to see if any bolts or nuts had worked loose. Everything was all right in this respect. The car was started again and the pounding commenced just as soon as it was under headway. A second examination was made, but without finding out anything further regarding the cause of the pounding. I took the car home, pound and all, and next day sent it to the repair shop for further examination. A close inspection revealed the fact that the contact blade of the commutator had become loose, on account of the unscrewing of the small brass nut which held it in place on its insulating block. This matter was remedied in a couple of minutes and a second nut put on the screw as a lock. On starting the motor no further pounding was heard and none has occurred since. This experience, however, goes to show that small things will make big troubles and that the cause is often in an entirely unsuspected place.

But if there is a popping or back firing into the receiving pipe it may need **more fuel** or the receiving valve may not close properly, or the igniter may not be set in proper time, or is otherwise out of adjustment.

**Too Much Fuel** is indicated when there is smoke issuing from the exhaust pipe and when the charges that are taken are not all ignited.

You can shut down a gas engine by feeding too much fuel just as readily as by not giving it enough. A little judgement here will tell any one when he is feeding the fuel properly.

It is a mistake to turn on **More Fuel when More Power** is wanted. When an engine is pulling nearly its full load it is cutting out only about one charge in five or six. By list-

## AND HOW TO CURE THEM.

ening closely to the sounds made by the engine and at the same time noticing it closely you will be able to judge whether it is running properly or whether it lacks the energy it should develop.

The **Compression** has very much to do with the power developed. For instance, if the valves are not seating properly or the piston rings are poorly fitted so as to allow the escape of part of the charge compressed and also a part of the impulsive force the engine will develop but very little more power than to keep itself in motion.

About thirty per cent of the entire cylinder volume should constitute **Compression Chamber**. If a high compression pressure is desired twenty-five or even twenty per cent is allowable.

You understand that it is necessary in figuring up cylinder volume to consider all the valve and port space which is practically a part of the cylinder. The principal objection to a high compression is the danger of premature firing of charges under a full load, which is due to auto-ignition, a result of high compression pressure.

High compression is sometimes, but by no means always, the cause of premature firing. In fact, I might say that it is one of the rare causes, because very high compression engines are rare.

**Smoke** at the end of the exhaust pipe means an over supply of fuel or a surplus of lubricating oil in the cylinder.

Set needle valve closer so as to feed less gasolene or gas. If this does not stop the smoke feed less lubricating oil into the cylinder.

**Smoke** at open end of cylinder indicates that there is either a sand hole in the piston, leaky rings, or that the lubricating oil in the cylinder is decomposed by the heat.

Piston taken out and filled full of water will test it for a sand hole or other leak.

When piston is out examine rings if broken or worn out, or show by wearing at only one or two places in their circumference that they do not fit the cylinder, replace them with new ones snugly fitted into the piston grooves, as well as turned to fit the cylinder. If lubricating oil is burning increase supply of cold water.

## DISEASES OF A GASOLENE AUTOMOBILE

**MUFFLER DISCHARGES.**—The explosions in the muffler are due to some of the charges in the cylinder not firing. These are forced out through the exhaust valve into the muffler. After a charge has missed fire the next charge is consequently richer and after ignition and expansion is still burning, so that when the exhaust valve opens it fires the unburned mixture left in the muffler from the previous charge.

If you find that when you retard your ignition that fire comes from your muffler you will also find that commutator or contact maker is set too far back, so that the motor fires some distance after the commencement of the outward stroke of the piston. **The ignition should be so set** that when fully retarded, the motor will fire just a trifle after the piston has passed the end of the explosion stroke.

**WATER IN THE CYLINDER** must be removed and the leak stopped. In some cases cracked cylinders or small pin holes may be remedied by filling the jacket with sal ammoniac solution (one pound to a gallon of water) and allow to stand one night. If this does not remedy the trouble then it must be plugged from the neck of the cylinder.

I have plugged leaky cylinders where the head was cast integral by drilling clear through the cylinder from the outside and putting in a brass plug clear through and tap down smoothly inside.

I recall a case of miss-firing and an occasional terrific report at the end of the exhaust pipe which was caused by the taper pin, which held the rocker arm to the movable stem, wearing loose and allowing lost motion at this point, which should have been rigid. A new and larger sized pin made out of a wire nail driven firmly into position completely overcame the trouble.

The lost motion made such an indefinite and uneven contact that only an occasional charge was ignited, which in turn ignited those previously forced through the cylinder, without ignition, into the exhaust drum and pipe, and the result was a terrific report at the end of the exhaust pipe, similar to the firing of a cannon. Every engineer should familiarize himself quickly with the natural sounds of his engine, and his ear will always be on the alert and detect any unnatural sound the instant it occurs.

## AND HOW TO CURE THEM.

Sometimes a motor may suddenly stop from the failure of the exhaust valve to seat properly. This may be due to the warping of the valve through the engine having run dry and become too hot, or it may be from the failure of the closing spring or the sticking of the valve stem in its guides. The valve should be removed, and the stem cleaned and scraped—or straightened if it requires it—until it moves freely in the guide and the closing spring given its full tension. If the valve still leaks so that the engine will not start or develop sufficient power, the valve will have to be ground into its seat.

One should always be on the lookout for "squeaks," for any such unusual noise is evidence of lack of lubrication, and generally foretells a breakdown unless heeded at once.

Now that the touring season is commencing, and the roads are in a fit state to travel on, it behooves us once more to warn all and sundry of the necessity, when approaching crossroads and corners, to give audible warning of approach. If all users of the road do this there will be little fear of accident, but if the present reckless method indulged by motorists of swinging wide at a rapid pace around turnings is continued, then fearful will be the results—not necessarily from cars, but from motor-cyclists also.

### Inlet Valves.

**Examine** your spring on **inlet valve**; if it is too tight it will not allow valve to open enough to take a full charge.

**If too loose** it will not close the inlet valve tight, and you will likely lose compression.

Frequently the stem on inlet valve becomes worn and allows valve to seat "lop-sided" and on several occasions my engine stopped, and on turning the crank the engine would turn free, not burning any compression at all; this was due to a particle of grit getting under the valve and again to the stem, wearing and allowing valve to set one sided, and again by oil clogging on stem and spring not being tight enough to close valve.

Ordinarily the mere turning of this valve a few times will remedy the trouble, and on turning the crank your engine will have the usual compression.

**Back firing** is the result generally of a leaky inlet valve; that is the valve does not seat good and the charge goes back

## DISEASES OF A GASOLINE AUTOMOBILE

into the carburetter. This trouble can be ascertained by looking inside of your carburetter, and if smoky it is a sure thing that your inlet valve is leaking and needs grinding.

I also know cases where the back firing occurred and the inlet valve was not leaking. Any projecting point of iron in the igniting chamber or chunks of carbon deposited in the cylinder may become heated to a red heat and serve to ignite the incoming charges before the valve is closed.

Frequently trouble is due to pieces of the scale from the inside of the cylinder having fallen and become wedged against the exhaust valve seat in such a way as to hold the valve slightly open, thus allowing a leakage by the valve.

**Weak explosions** indicate leaky valves. If there is a continual back firing in the carburetter the inlet valve springs are weak, and require more tension by pulling them out. It is good policy to have the inlet valve springs of the same tension. This can be easily arrived at by putting the two valve stems together when the valves are mounted and see which opens first.

**RELATION OF SPARK TO GAS MIXTURE.**—The relation of time of spark to the gas mixture is a thing best learned by experience, but most always the highest speed will be obtained where throttle button is at its highest point and the sparker lever well advanced. It, however, happens on bad roads and hill work that best results are sometimes obtained by lowering sparker a trifle, leaving throttle wide open. With the throttle nearly down and the sparker way down the motor will just run itself. Do not open throttle suddenly, as the mixture will be more uniform if the throttle button is raised gradually.

Do not advance ignition until your engine is up to speed on throttle; advancing the igniter suddenly, or before you attain speed out throttle will cause pounding. Always advance ignition after the throttle.

**MIS-FIRING.**—Means failing to fire each charge the engine takes, and the remedy has already been given. It consists of examining the battery and all its connections to the terminals, and determining whether the battery is exhausted or not, whether there are broken connections, whether the terminals or other points need cleaning or attention otherwise. Also determine whether fuel is fed to the engine in proper quantities. May not be getting enough at a charge or even too much.

## AND HOW TO CURE THEM.

**MIS-FIRING IN MOTORS.**—If the spark plug is covered with soot or grease mis-firing will often result. A spark gap device placed in the secondary circuit will generally overcome this difficulty, but prevention is better than cure and over lubrication should be avoided and the best grade of cylinder oil used.

One of the most common causes of mis-firing is an improper mixture of gasoline and air. Too much air or too much gasoline will cause mis-firing. The remedy is obvious.

A loose connection in the primary or secondary circuit is another source of mis-firing. A loose wire may be in contact and allow one or two explosions to take place. The vibration of the car afterwards may shake the wire loose from its contact and then the motor will mis-fire. All connections should be carefully cleaned and screwed tight.

Short circuits and current leakage by contact of a bare place on a wire with some metal portion of the car, or by a spark plug with defective insulation will also cause the motor to mis-fire. The spark may arc or jump elsewhere than between the platinum points of the plug, rendering a new plug or fresh insulation necessary.

Batteries which are almost exhausted will give rise to explosions in the motor cylinder which seem all the more violent on account of their irregularity. This should be the time to switch on the extra set of batteries, if one is carried. It is perfectly useless to connect the exhausted cells with the new set, either in series or parallel, as it will reduce the new cells nearly to the voltage of the exhausted ones.

Closing the points of the spark plug will help the batteries and enable the operator to get the car home, if he has no extra set.

**CARBURATION.**—Too much mixture or too rich a mixture cause increased heat.

**LUBRICATION.**—Insufficient lubrication increases the friction between piston and cylinder, and so generates extra heat. Bad or unsuitable oil may have the same effect.

The results of overheating are often most serious. In extreme cases the head of the cylinder may warp and the joint need refacing—a difficult workshop job, only to be undertaken by an expert. The pistons may seize and score the sides of

## DISEASES OF A GASOLENE AUTOMOBILE

the cylinder, necessitating the engine being taken down before it can be freed. The temper of the valve springs, too, is injuriously affected.

**BAD COMPRESSION.**—Compression is a term which signifies the pressure of the gas in the cylinder, when the piston is at the highest point. On this pressure or compression depends the power of the engine. Every engine is designed to run with a certain compression, and there is a very close connection between this compression and the other portions of the engine, so that any variation must affect the power of the engine.

Compression should always be kept at the highest pitch for which the engine is designed, but to increase the compression by the addition of a compression plate—that is, by reducing the space in which a full charge of mixture is compressed between the piston and the cylinder head is not advisable, except on a motor expert's advice. The same holds good for reducing the compression by fitting a plate between the cylinder and the crank chamber, thus increasing the compression space.

The simplest rule-of-thumb way of testing compression is by means of the starting handle. If there is no compression, the handle will turn freely, whereas, if there is distinctly less compression than when the engine is at its best, the operator may conclude that the explosive mixture is leaking. By experience in starting he will learn exactly how great the resistance should be.

There are many causes for the leakage of compression, which we shall now proceed to enumerate:—

**THE VALVES.**—In the process of time the surface of the valves becomes pitted, allowing part of the compressed mixture to escape between the valve and its seat. They need immediate grinding. See Valves. If they are dirty they are liable to lag in shutting, thus also affecting the compression. After being newly washed, there is also a certain amount of loss, which, however, disappears when the car has run some miles. A weak inlet spring will allow part of the charge to escape at the beginning of the compression stroke, and blow back into the carburetter. In the case of the inlet valve, the joint between the cylinder head and the valve may be faulty, thus al-



## AND HOW TO CURE THEM.

lowing the compression to escape here. To test this, brush soapy water round the joint when the engine is working, and if there is a leakage bubbles will appear. The joint must be well cleaned, treated with boiled linseed oil, and the valve replaced. See Valves.

Sometimes the lost compression is caused through the inlet valve breaking through it sticking open, through the spring getting twisted or misplaced, or the pin of spring getting lost. In the case of the exhaust valve a bent spindle or a dirty guide may cause the valve to stick up. Also if the spindle is too long, the valve may not shut completely, thus allowing part of the compression to escape at each stroke.

**TUBES.**—In the case of tube ignition there is sometimes a leak between the tube and the cylinder wall. A lighted match held in close proximity, or the use of soap-suds will locate it. It may be that the tube simply wants to be screwed home, or that it requires a new washer. If the tube becomes cracked, a new one of the same length and make should be fitted. If a new one is not available, the defect can sometimes be temporarily remedied by removing the tube and gently hammering it, so as to close the crack.

**THE PISTON RINGS.**—To ensure proper compression, it is absolutely essential that the piston rings should be kept lubricated, consequently when the engine has been lying for some time, the compression at the start is often poor. Any failure in the lubrication while running will, of course, have the same effect, such, for example, as obtains in the case of overheating, or when the supply is intermittent. Sometimes the piston rings get stuck in their grooves with burnt oil, through overheating, and the compression escapes past them. Thorough cleaning with paraffin and fresh lubrication will settle matters. In engines where the rings are not pinned in position, the slits may work round so as to coincide. In this case they will have to be shifted. (See Piston Rings.) Sometimes burnt oil may, apparently, have the opposite effect on piston rings, for by causing the piston to grip in the cylinder, it will produce considerable resistance, and the operator might erroneously think in consequence that his compression is good. In every case, after a day's run, a little kerosene should be injected into the cylinders to clean the rings.

## DISEASES OF A GASOLENE AUTOMOBILE

**POROUS HEAD OR LEAKY JOINT.**—The symptom in this case is the presence of water, which will get into the cylinders and affect both the lubrication and ignition. Its presence may be detected by drawing off the oil in the crank chamber, when the water will be found at the bottom. Steam showing in the exhaust is also an index, but not an infallible one, as it is also caused by fog or wet weather. If the joint is a defective one, it will have to be re-made by an expert. If the head is porous, a new head will be required.

**OVERHEATING.**—This will at once affect the compression, because the burnt oil carbonizes on the piston rings, and allows the gas to escape.

**LUBRICATION.**—If the oil is bad, it will affect the compression through the piston rings.

**COMPRESSION TAP.**—Some engines have a compression tap fitted, and very often the pressure escapes by this means through the tap being a bad fit. Grinding in will generally put the matter right.

**KEROSENE OILER.**—Some engines are fitted with a kerosene oiler on the top of the cylinders for cleaning purposes. Here, too, a leakage may occur.

**MAGNETO IGNITION.**—In the case of magneto ignition the pressure may escape through burnt or worn washers, which will consequently need immediate renewal.

**STOPPAGE OF ENGINE.**—The cause of a sudden and complete stoppage of the engine is more easily to locate than intermittent or sluggish running. We shall treat of the various causes in their order of frequency.

**PETROL EXHAUSTED.**—The car will have been traveling at her best when suddenly she will slow, give a few expressive pops and stop quietly and noiselessly. If pressure feed is fitted, the pressure will immediately escape.

The best test, however, either for pressure or gravity-fed engines is to lift the float spindle, and see if the carburetter will flood. If it does not do so, it may be taken for granted that the tank is empty. If it does, the cause of stoppage must be looked for elsewhere. Sometimes the driver will forget to turn

## AND HOW TO CURE THEM.

on the petrol at all, and the car will stop after running all right for a short distance on the contents of the carburetter.

Misfires or explosions do not accompany failure in the petrol supply, and by this means it can be distinguished from a stoppage from ignition troubles.

**IGNITION.**—If the battery is run down, the car will run sluggishly and-jerkily, there will be misfires and explosions, and finally the engine will stop. If an attempt is made to restart some minutes later, the engine will in all probability run all right for a few minutes, the battery having temporarily recovered. A new or freshly-charged battery is the remedy.

In a single-cylinder engine the complete breakage of a wire, the loosening of a connection, the breakage of a plug, or the displacement of the wires in a plug will cause an instant stoppage. In a multi-cylinder engine such an accident will only slow the car and cause one cylinder to miss, with the result probably of explosions in the silencer. See ignition.

**VALVES.**—In a single-cylinder engine a broken inlet or exhaust valve will cause an immediate stoppage. A broken or displaced spring in the inlet valve, or a stuck-up exhaust valve will have the same effect. In a multi-cylinder engine there will be a loud sucking noise, and the car will slow.

**OTHER CAUSES.**—Choked filters, choked jet, or choked supply pipe may wholly cut off the petrol supply and cause a stoppage. As a rule, the stoppage from these causes is not immediate, but is preceded by intermittent running.

Water in petrol may cause a sudden stoppage.

A loss of pressure in pressure-fed engines is another cause. In gravity-fed engines, when the petrol is low and the car left standing on a slope, the petrol may fail to reach the exit.

If the governor strikes work through failure of the springs, lever slipping out of notch, or any other cause, the engine will at once stop. Sometimes a stoppage will occur through the driver closing the hand throttle by mistake.

**OVER-HEATING.**—The immediate effect of over-heating is to burn up the oil in the cylinders or crank chamber. This causes a smell of burning and an odor of hot metal. There is sometimes a slight smoke and the engine will make a knocking noise. The water begins to steam, and the car will gradually

## DISEASES OF A GASOLENE AUTOMOBILE

slow down and even eventually stop. In extreme cases the piston will stick or, in motoring parlance, seize.

Beginners often experience difficulty in telling if the engine is really over-heated or not. An infallible test in the case of a water-cooled engine is to let a drop of water fall on the head of the cylinder. If it fizzes for a few moments the case is not a bad one, but if it at once condenses into steam, the matter is serious.

The first thing to be done is to stop the engine, and take off the bonnet and let the air get in. Then detach the sparking plug or plugs, and work the starting handle. This draws in cold air and cools the inside of the cylinder walls and the piston. On no account throw water on the engine, or put cold water into the tank until the engine is comparatively cool. In either case a burst jacket might result. When the source of the trouble is discovered and remedied, some kerosene should be squirted into the cylinders to clear off the gummy deposit caused by the burnt oil. Then lubricating oil should be forced in both to the cylinders and crank chamber and the tank filled up with cold water.

Should the over-heating be caused by the tank running dry, or by the water escaping by the fracture of a pipe or such like, the tank should on no account be re-filled until the engine is quite cool.

**POOR COMPRESSION.**—Poor compression as we have already mentioned may be caused through the valves. We have already dealt on the remedy for this, also when the piston rings become clogged a little kerosene put through the compression taps will remedy this as already suggested. The spark plug may not be screwed right home or the gasket may be broken or a leak might have sprung around the porcelains of one of the spark plugs and the only remedy for this is to replace them.

**IF SPEED GETS LOWER AND ENGINE FINALLY STOPS,**—suspect:

First—Irregular ignition; charges not all fired.

Second—Overheated cylinder or piston.

Third—Hot journal or wrist box.

Fourth—Overload on engine.

Fifth—Fuel supply exhausted.

Sixth—Exhaust or receiving valve leaking.

## AND HOW TO CURE THEM.

### REMEDIES—

First—Repair broken wire connections, clean electrodes or igniting mechanism, repair insulation, renew battery, attend to magneto or sparking dynamo.

Second—Increase supply of cold water and lubricating oil.

Third—Stop engine, examine hot box, if cut any, dress all rough places, and wipe out all filings or cuttings, readjust boxes to bearings carefully, lubricate well, start engine and keep a close watch on it for several days. If it shows any tendency to heat examine again and readjust.

Fourth—Reduce load on engine.

Fifth—Replenish fuel supply.

Sixth—Grind the valve that leaks to a good seat with emery flour and oil.

**CLUTCHES.**—If treated with **Castor Oil** will work better and not gum.

**MOTOR:**—If in running the machine, should the motor develop a knock or begin to labor it is due to one of three things.

First—Spark being too far advanced for the speed at which the machine is traveling.

Second—Lack of water.

Third—Lack of lubrication.

To remedy the former, pull back the spark lever and if knock does not stop, turn off the switch to stop the motor. If the motor should continue to run, even with the switch turned off open the compression taps and it will then stop. If it is lack of oil which causes the motor to overheat, put in about a pint in the crank chamber by undoing the thumb screw which is on the side of same. If it is lack of water the only remedy is to refill the tank. If there is ample water in the tank then either the pump is not working or one of the tubes of the radiator is clogged through some foreign matter getting into the tank. Care should always be taken in filling the tank to strain the water by passing it through the funnel provided with the machine.

If the motor turns over hard at any time after a long trip, inject a little kerosene oil down the compression taps so as to allow the kerosene to cut away the carbonized oil on the piston rings and cylinders. If the engine is hard to start after

## DISEASES OF A GASOLENE AUTOMOBILE

a trip the possibility is that the inlet valves are also stuck through feeding too much oil to the cylinders or through running the motor with too rich a mixture and the only remedy for this is to get the valves out and thoroughly clean them.

If the engine starts missing open up the compression taps and find out which one it is. This can easily be determined by the sound. Take out the spark plugs and clean same if necessary and if the engine still keeps missing with the spark plugs cleaned, it is either up to bad adjustment of the vibrator or weak batteries, points with which we will deal later on.

**DONT'S.**—Don't turn crank to start until your switch is on and you know that you have gasolene in your tank.

Be sure that your igniter is set back or it will "kick" and possibly sprain your wrist.

Don't fill your gasolene tank too full, leave air space on top or it will not flow.

Don't have any open air holes in your gasolene tank; when your rig is washed water may run in this hole, mix with gasolene and cause trouble.

Don't use grease in the crank case of your engine, it will clog up the oil holes and prevent the thinner oil from circulating.

Don't fill your gasolene tank by lamp light.

Don't keep on running when you hear an unusual noise about your machine, stop and find it.

Don't start or stop suddenly.

Don't leave starting pawls running on their rackets.

Don't let driving chain get loose.

Don't let clutches get loose.

Don't let oil get on clutch rims.

Don't try and run carriage with spark lever down.

Don't run fast on too low a gear.

Don't run with brake set.

Don't forget to keep tires pumped up.

Don't forget that oil is a mighty good thing to use on bearings.

Don't try to start motor with the sparker lever up.

Do not pour gasolene over your soiled hands and then rub them together. That rubs the dirt into the skin. The proper way to do is to saturate a towel with the gasolene and then wipe the dirt off.

## AND HOW TO CURE THEM.

When you are going to make a stop, always throw sparking lever forward: it will prevent racing of motor while clutch is out, providing, of course, you do not throw out switch altogether.

If the motor turns hard it is an indication that the cylinder is dry; see that the lubricator is working properly.

Always have sparking-lever forward when starting or it will kick back when you come to turn the crank.

In case of starting the motor when it is hot and the cylinder is a little dry, it will be necessary to use a little earlier spark to give the required force to the explosion.

If the motor misses explosions that you cannot locate, and you wish to run back, keep your hand on the clutch-lever and only connect enough to run forward and release the clutch, and allow motor to pick up speed when necessary.

Never allow motor to race or run fast when clutches are out; always release speeder; and if you are going to stop for a few seconds without stopping the motor, move sparking-lever forward so that motor will run as slow as possible.

Never allow motor to stand in such a position that the battery is connected that the buzzer of sparking-coil will work; it is the same as a short-circuit, and will run down the battery rapidly.

**Never** fill gasolene reservoir by **lamp light**, and never fill it higher than one inch from top; there are two partitions in the tank, which will retard filling somewhat. The motor will give best results if gasolene tank is not over three-quarters full.

Never leave vehicle with motor running; a slight touch of the clutch-lever will cause the carriage to leave you.

Whenever the motor slows up from overload throw out clutch-lever quickly or it will stop.

Always use speeder wide open when going up a steep grade. Never use very early spark only when motor is at high speed; even then should the motor slow down ease up on the early spark to an upright position.

If you stop on a steep place, back up and try again instead of trying to start on a steep grade.

## DISEASES OF A GASOLENE AUTOMOBILE

If moving around in a building or crowded street always keep your foot ready to apply the brake, and reduce the speed of motor by means of later spark.

Always pick out good roads for your machine; to run over stones and rough places means unnecessary wear and tear on it.

In case the motor does not start readily, try more gasolene and vary the speeder.

Should gasolene run out at suction, it would indicate that the overflow was stopped up; this would also stop the engine from working.

On a very cold morning a little gasolene on the suction-screen will make it start easier.

Never turn starting-crank continuously; if it does not start from one to six turns there is cause for it; look around and see what you have forgotten to do.

If, at any time, there is any soot collected around igniting points, it should be removed.

The brake-bands which operate the clutches should never touch when thrown out.

White smoke at exhaust when going up grade is caused by too much oil in crank-case, and should be drawn off at oil-drip under crank; if this drip is opened occasionally this will not occur.

In case water should get into the cylinder by means of any leakage, open the air-cock at the back end of the cylinder and give motor a few turns to work it out.

A little water in the gasolene will cause no end of trouble by causing motor to stop. It may be removed by tilting the vehicle so that it will allow it to escape at the rear drip plug in tank, and also at drip-cup next to needle-valve.

Always keep out of the way of the crank when motor is stopping; it might take a turn backwards and take the crank with it.

On approaching a team, always let up on speeder to reduce the noise as low as possible.

If in starting motor you come up against compression while your heel is on release-lever, let it cushion back enough to admit relief-cam.



## AND HOW TO CURE THEM.

Never use too rich a mixture; it causes trouble by deposit on valves and muffler, as well as firing-plug.

When motor does not ignite regularly, it may be due to one of five things:

First: Not enough, or too much gasolene.

Second: Loose wire connections on battery or engine.

Third: Short-circuit at ignition plug.

Fourth: Changing the adjustment of buzzer on spark-coil.

Fifth: Weak battery; but not likely unless used for four or five months.

### DONT'S ON THE ROAD.

In meeting another vehicle take to the right side of the road early, that the other driver may do the same.

In overtaking a vehicle, do not at once pass to the right, but wait until you have gained a lead of at least 100 feet.

In going down hill, give the right of way to an ascending vehicle, and even stop, if that should be necessary.

Do not cut turns short without having first made certain that there is no vehicle approaching from the opposite direction.

Do not pass through villages on the fourth speed; you will not excite the admiration of anyone and run the risk of deserved arrest.

When you find it necessary to stop abruptly, raise your hand to signal drivers who may be following you.

When you leave your vehicle on a down grade, do not forget to block your wheels; your hand brake may slip and in that case you would be likely to find your machine at the foot of the grade in the ditch.

In mountainous country it is well to carry a drag, to be applied with a handle, in addition to the sprag.

If a repair becomes necessary on the road, proceed slowly and methodically—you will thereby gain in time.

Use the utmost prudence, always and everywhere.

### IN THE STATION.

Do not smoke while filling your gasolene tank.

Do not take out all the spark plugs when there is nothing the matter except that there is no gasolene in the tank.

Do not forget to purge the motor with kerosene or gasolene just after stopping it.

## DISEASES OF A GASOLENE AUTOMOBILE

Do not apply a match or small torch to the carburetter to re-heat it, because it sometimes leads to unexpected results.

Do not grind in the valves any oftener than is absolutely necessary.

If the cone of the friction clutch slips, spread some of the residue found in the acetylene generator over the leather lining.

In case a bearing shows a tendency to heat, throw some flower of brimstone on it.

**NOT ENOUGH GASOLENE.**—Not long ago my machine stopped for lack of gasolene. I secured about 1 quart from a nearby house. Putting this in my tank I proceeded to crank my engine, it did not start. I then flushed my carburetter and found that I was not getting gasolene at the carburetter. I felt positive that a quart of gasolene was sufficient to start with. On investigation I found that the front of machine was setting up hill back part down hill and the gasolene was in the rear part of the tank and did not flow down the gasolene pipe. Moving the machine back on the level it started at once.

**DON'T EXPLORE THE INTERIOR OF THE CYLINDER WITH A MATCH OR CANDLE.**—It is sometimes necessary to explore the interior of the gas engine cylinder with a lighted candle, for the purpose of locating some sharp projection, burnt carbon, crack or sand hole, etc. When doing this always re-



Don't use a match.



Use a Hand Electric Lamp.

member that a **charge of fuel** may remain in the cylinder, and whether the candle is inserted through one of the valve ports or the open end of the cylinder, be sure to keep **your face** away from the opening.

The lighted candle will ignite the charge, and the flash through the open port may result in a seriously burnt face. The candle is usually put into the cylinder on the end of a

## AND HOW TO CURE THEM.

long, sharp, pointed wire or stick, use an **Electric Hand Lamp**.

**Never use** very late spark continuously while on the road; it will cause greater heat and unnecessary waste of gasoline.

Never make a quick turn of the steering lever while the vehicle is running at a high speed; it is liable to cause a bad accident.

Do not allow motor to run slow enough to give jerking-motion; if it should, at once move clutch-lever back for an instant to allow engine to increase speed again.

Don't let the chain—if a chain is used—become slack or it will soon be riding on the outer edge of the sprocket. Also keep the chain clean and well lubricated.

**ONLY THIS AND NOTHING MORE.**—There are no more automobiles here. A boy; 500 gallons of gasoline; an open ten-gallon can of same; five automobiles; one naked flame lamp. These ingredients became mixed. Result: one boy scorched and badly scared; one heap of ashes; some badly twisted metal fragments. No insurance. No more automobiles. No nothing. That's all.

**SUGGESTIONS FOR NOVICES.**—Amateur automobilists should never neglect to retard the ignition mechanism before cranking the motor. A back-fire will result if it is neglected, and a nasty blow, or even a broken wrist or arm may be the result. The best way to avoid this trouble is to have the ignition actuating lever or pedal, spring controlled so that it is always retarded when not in use.

The beauty of knowing how to repair or adjust the minor parts of a car—which generally are the cause of trouble—can only be estimated when troublesome conditions are encountered, miles away from a repair shop. Beginners should make an intelligent study of the mechanism of their cars before attempting a long trip.

The best medicine for a slipping friction clutch, with a leather face, is an application of Fuller's earth, it can be had at any drug store.

Motor troubles sometimes occur from a "stuck" exhaust valve—that is the stem becomes clogged or gummed up and the valve does not seat. The valve should be removed and the

## DISEASES OF A GASOLENE AUTOMOBILE

stem and its guide thoroughly cleaned. If the valve should still leak the valve and seat need regrinding.

High powered motor cars if much used should have a thorough overhauling and cleaning at least once in two weeks. If this advice is heeded fewer road troubles will occur. However, this does not mean a lot of unneeded readjustment.

With a three or four-cylinder motor it is a good plan to have the ends of the wires and the terminals to which they connect numbered, or in some way marked so that each wire can be easily connected to the right terminal. As there are four wires leading from a three-cylinder contact-maker and five from a four-cylinder one, there are twenty-five possible connections for the wires, of which only one is correct.

Each oil supply pipe in a mechanically operated lubricator should have its own source of pressure, or small pump, in order to ensure a positive feed. In some makes which have a common source of pressure, or a single pump, if one or more of the small pipes should become clogged the others will receive too much oil. Sometimes the wiring on a car is exposed to continual, if even slight, friction against some part of the mechanism of the car. The entire system of wiring should be frequently examined and defective insulation looked for, as an unexpected break in the insulation of some part of the wiring will cause a short circuit, generally resulting in the stopping of the car.

All wiring on the vehicle should be kept as far away as possible from the exhaust pipe, muffler, or other heated portions of the motor. If too close the insulation will probably be ruined at that point.

The fuel tanks of both gasoline and steam cars should be made with the greatest possible amount of care to prevent the slightest chance of leaks. They should preferably be located a considerable distance from the motor, so that if a leak does occur the gasoline will run directly on to the ground.

By carefully following the instructions issued by the makers of the various types of cars in use to-day, good results can be secured, and if care is taken to keep the vehicle and parts clean and up to "concert pitch" the mechanism will not only run well, but will last longer than a dirty and neglected vehicle ever can.

## AND HOW TO CURE THEM.

Do not omit to keep the dustcap on a Michelin valve. Nearly all these valves leak more or less, but the dust-cap will stop the leakage, as it has a rubber washer inside.

When reversing, be very careful not to put in the forward gear before the car has stopped traveling backwards; several people do this, but it is extremely bad for the gear.

It is a very good plan to fix light leather guards inside the front wheels; most cars splash a good deal of oil up from the engine, and the oil bespatters the wheels and tires.

A thick piece of rope has often been suggested to put on a rim in place of a burst cover when everything else fails, but there is usually some difficulty about securing the rope; a very good method of effecting this is to measure the rope round the rim to get the length, and then to unite it by a short splice. The short splice will take up about three inches or more of the rope, and it will then have to be forced on, but when this is done it will not readily come off.

It should be remembered that cars with low-compression engines and trembling coils do not need a very small spark-gap. Panhards and similar cars work very well with a spark-gap of about one and a quarter millimeters.

Never continue running a car when a suspicious squeak or knock is heard; many dollars' worth of damage may be done in this way; investigate any unusual sound at once.

The great secret of hill-climbing is not to change speed too late; change on to the third speed while the car is still running at a fair speed on the fourth.

**ROADSIDE STIMULANTS.**—Leaky joints in gasolene or water pipes may be made tight by means of coarse linen or canvas, covered with a paste of litharge and glycerine. This should be again covered with a bandage of adhesive or sticky tape, such as is used for electrical purposes. When out on the road, if the brakes should be found not to hold properly, they should be adjusted immediately before any serious accident may happen. The trouble may be due to grease or oil having covered or saturated the brake bands, in which case they should be thoroughly cleaned with waste or old rags. If the trouble be due to improper adjustment, a few minutes' use of a wrench will generally set matters right.

## DISEASES OF A GASOLENE AUTOMOBILE

### Packing.

**FOR GASOLENE ENGINE CYLINDERS,** heads and valve chambers are usually asbestos. There is also a packing called Rubber Bestos and a Copper packing which is sometimes used. Asbestos however is the material commonly used. In making a jacket or packing to go between your cylinder head and head of your inlet valve and cylinder head it is necessary first to take a piece of asbestos the proper size and thickness and put it on the valve or head and hammer it out to the shape of the place to be covered.

This packing of asbestos is then thoroughly soaked in **linseed oil** and applied and head set on and nuts drawn up tight.

After running engine for an hour or two tighten the nuts again and it will very likely last you a long time.

Be sure that the asbestos is of the right thickness, for if it is too thin it will increase your compression slightly and if too thick it will decrease it. Try and get asbestos or packing the same thickness as that which came in the engine originally.

In putting in copper-asbestos washers, they should always be slightly rubbed with blacklead, when the parts screw together, as in the case of sparking plugs and some inlet valves. Where valves are held down by a bridge and nut, the latter cannot always be given sufficient pressure to make a tight joint, and it is advisable to tap the valve-seat all round with a mallet, when in place, to bed the copper washer down and ensure a good joint. The small American raw-hide mallets are most useful for this and similar purposes in the car-shed.

In re-packing a pump gland use plenty of graphite with the packing. The spindle is seldom sufficiently lubricated, and the graphite will go a long way towards remedying this. Glycerine in the coolingwater, as a frost preventive, seems incidentally to considerably assist in lubricating the pump spindle. We have noticed it has been less frequently necessary to take up the packing during the winter in a car where it was employed.

**COPPER CYLINDER HEAD PACKING.**—What is the best packing to use between the cylinder head and cylinder? I am continually having trouble on account of the asbestos packing blowing out.

## AND HOW TO CURE THEM.

Soft sheet copper about 1-16 of an inch thick will make a good packing for the purpose. Grooves of V shape should be turned in both the cylinder head and top of the cylinder, into which the copper gasket is forced when the nuts are tightened.

**ANOTHER METHOD—An Improved Method of Cylinder Head-Packing.**—Recently many complaints have been heard about difficulties in packing the cylinder heads of engines used in several well known automobiles. Such complaints are hardly just. Failure through blowing out of cylinder head gaskets need not occur if the job has been properly executed, and criticism of constructions necessitating such packing tends to prejudice the prospective purchaser against machines otherwise of merit. Lack of knowledge of what happens "out on the road" has led many thoroughly practical constructors, designers and shop men into making mistakes, which are recognized as such only by the users and operators. Since such is the case it behooves the shop man to come forward with a little advice to the just as well meaning, but not quite as mechanically trained man "behind the wheel," pointing to a method of putting in gaskets which has proven very efficient and which has been practiced in many shops throughout the country.

The sheet packing, commonly known as "Kearsage" brand, an asbestos-rubber composition with an intermediate layer of wire netting, already incorporated into the packing, has been the most satisfactory medium for securing permanent cylinder head packing. Single thickness is preferable to double.

The order of operations in packing a cylinder head would be about as follows (the gasket is supposed to be in readiness):

Scrape flat packing surfaces on the cylinder head, as well as on the cylinder end, with a putty knife or similar piece of flat steel until all particles of the old packing, soot and dirt have been removed. It is very essential to remove all traces of oil. If gasolene is employed for this purpose, care should be had to do this so thoroughly that no thin film of diluted oil remains spread over the packing surfaces. As a safeguard it is advisable to follow up the gasolene wash with one of wood alcohol.

Coat the flat packing surfaces on cylinder end and head with a layer of yellow shellac dissolved in alcohol, using a paint brush for this purpose. When it does not "stick" to the touch

## DISEASES OF A GASOLENE AUTOMOBILE

of the hand any more put on a second coat of shellac. Wash the gasket well with wood alcohol, removing all trace of soap-stone and grease.

Between the first and second coat to the cylinder surfaces the gasket has applied one painting with the same shellac solution. After the second coat to the engine parts the second coating is applied to the gasket also.

If openings are to be cut into the gasket for water circulation for ports, especial care must be taken to cut these openings in the gasket about three-thirty seconds of an inch larger all around, because the packing, upon being compressed by the studs will become, larger, "grow," as it were, and protrude with its edges into the apertures referred to, and, if some of these communicate with the combustion space, self ignition will often occur after a short time, owing to ragged portions of the packing becoming incandescent and remaining so for a long time.

The gasket may now be placed over the studs upon the cylinder end, and the head over the studs upon the gasket. Screw up all nuts evenly in rotation, little by little, giving each one a few turns until it "draws," going to the next one, and keeping this process up until all nuts are known to be equally and sufficiently tight to permit of starting engine. Of many other jobs, which cannot be hurried and give good results, the screwing down of a packed head is one. The packing material needs time to be compressed and accommodate itself to the new conditions. If the drawing up of nuts is done slowly, it is surprising to note how often one can return to a nut and take up just about a quarter turn after it was believed to be "home" as far as it would go.

The engine may now be started up. When cylinder and head are well warmed up, after running for about half an hour, go around the entire set of studs and again draw up the nuts. Nearly in every instance the total amount of taking up which can now be done will be found to aggregate almost one entire turn of each nut. Do this gradually, as described above. After several hours' running it is advisable to go around the nuts again, repeating this operation during the next few days after putting in a new packing. A cylinder head, packed in the



## AND HOW TO CURE THEM.

manner described, will remain "tight" for many months. The process described may not be a very rapid one, but it is certain to give good results and obviate repacking for a long time. It will also lessen complaints about heads which do not "stay" packed.

**HORSE POWER EXPLAINED.**—Every engine uses a certain per cent. of its total power to drive itself.

**A. H. P.—Actual Horse Power**, means the power an engine has to spare for driving other machinery after driving itself.

**I. H. P.—Indicated Horse Power**, is A. H. P. plus the power an engine requires to drive itself.

**Total Power** of an engine is the same as its I. H. P. B. H. P., **Brake Horse Power**, same as A. H. P.

If an engine develops on Brake Tests, even Brake Horse Power, or Actual Horse Power, and it takes 3 H. P. to drive itself, it is therefore properly called a **ten indicated and seven actual** or Brake Horse Power.

**Indicated Horse Power** is determined by an instrument called an **indicator** attached to the compression chamber of the cylinder, which is capable of indicating the pressure behind the piston by tracings on a card. The power is figured from the area of this tracing.

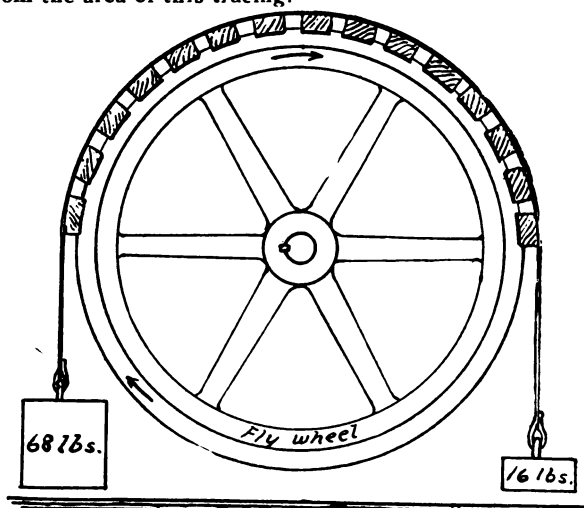

**BRAKE TESTS.**—A piece of belt with linwood cleats fastened to it with wood screws, as per the above illustration, will serve to make an excellent arrangement for testing, brake or actual horse power.

## DISEASES OF A GASOLENE AUTOMOBILE

On each end of this brake a paint bucket with bail or handle hung onto hooks fastened onto the ends will serve to hold small stones or chunks of iron with which to weigh the brake and cause sufficient friction.

This weight is applied until the engine is pulling all it will pull without materially reducing the speed, and the weights on each side balance or hang clear of the floor.

The engine is then left running under its load for from ten to thirty minutes, during which time the speed is counted a number of times, to determine whether the engine holds the same speed.

When you have maintained the same speed for some time the test may be concluded by stopping the engine.

The weights on each end are then weighed and the difference in pounds is the number of pounds pulled by the engine.

By multiplying the **circumference of the wheel in feet** by the number of pounds pulled by the number of revolutions per minute, and dividing this product by 33,000 the result will show the actual or brake horse power of the engine.

**EXAMPLE.**—Diameter fly wheel shown in above cut thirty inches, or two and a half feet.  $2\frac{1}{2} \times 3.1416$  equals Cir. 7.85 ft.

Cir. Rev. Pounds.

7.85 ft. x 300 x 52 equals 37-10 H. P.

A power capable of raising 33,000 pounds one foot high, in one minute, equals one horse power.

**MAKING PRONY BRAKE TEST.**—The horse power of a bicycle motor may be ascertained by the use of a Prony brake, but on account of the small amount of power developed by such a motor and the high rate of speed at which it is generally run, to develop its full power, a special form of Prony brake is necessary. It will be necessary, also, to have the motor cooled by

means of a fan, operated either by the motor itself or by some other source of power, in order to get accurate results, for the motor would be liable to overheat, otherwise, there being no natural draft.

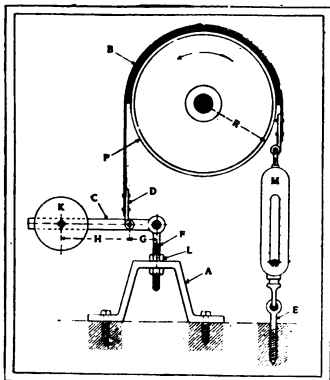

The illustration shows a form of Prony brake well adapted to high speed motors. A semi-circular band of thin steel lined with leather or fiber, is bent to conform to the curvature of the motor driving pulley. If the motor is fitted with a chain sprocket this must be removed and a pulley

temporarily substituted. The band is provided with lugs at

## AND HOW TO CURE THEM.

each end so that one end of it may be fastened to a weight lever and the other to a small spring scale capable of weighing up to about 50 pounds. The motor should be firmly mounted on blocks on a bench and at a sufficient height to allow the lower end of the scale to be secured to the bench.

The brake band B should firmly embrace the upper half of the pulley P, and be connected by the lugs D, at one end to the spring scale M and at the other end to the weight lever C. The spring scale M should be attached to the bench by a screw eye E, while the weight lever C is carried by the eye bolt F, which has adjusting nuts L, and is supported by the bracket A.

The formula for this style of Prony brake is as follows:

Let M be the pull indicated by the spring scale in pounds; R the radius of the pulley in inches, and N the number of revolutions per minute of the pulley. Then if B. H. P. be the actual brake horsepower,

$$\text{B. H. P.} = \left( M - \frac{2H \times K}{G} \right) \times \frac{R \times N}{63,025}$$

The following is an example of the use of the formula: At 1,800 revolutions per minute the pull on the scale M is 30 pounds; the weight K is 2 pounds, and is 4 inches from the lug D, the distance G, being 2 inches; and the pulley is 4 inches in diameter. Then 30 pounds minus (2 multiplied by 4 and divided by 2) equals 22 pounds, the efficient pull on the brake band. Then 22 multiplied by 2 and by 1,800 equals 792,000. This divided by 63,025 gives 1.25 as the brake horsepower of the motor.

In making brake tests the motor should be tested at varying speeds, both above and below the normal speed, as in many cases a slower rate of speed with a heavier pull on the scale will show greater power, than a higher rate of speed with a lighter pull on the scale. By this means what is known as the critical speed of the motor, or the speed at which it gives its best results, may be readily ascertained.

**QUESTIONS OF HORSEPOWER.**—I am building a gasoline motor of 4-inch bore and 4½-inch stroke. What horsepower should this motor develop and what diameter and weight of rim should the fly wheel have?

## DISEASES OF A GASOLENE AUTOMOBILE

A motor of 4-inch bore and  $4\frac{1}{2}$  inch stroke should develop 4 horsepower at 900 revolutions per minute. The fly wheel should be 15 inches in diameter and the rim should weigh 50 pounds.

What should be the bore and stroke of a four-cycle gasoline motor to develop 5 horsepower at 1,500 revolutions per minute? Also what per cent of grade should a 5-horsepower motor take a car weighing 800 pounds at the rate of 10 miles per hour?

A motor of  $4\frac{1}{2}$ -inch bore and stroke will easily develop 5-horsepower at from 1,200 to 1,500 revolutions per minute. A 5-horsepower motor should take an 800 pound car up a 20 per cent grade at a speed of 10 miles per hour.

What horsepower should a single cylinder motor of 6-inch and  $6\frac{1}{2}$ -inch stroke develop at 600 revolutions per minute and what should be the length of the clearance or space in the combustion chamber for a compression of 60 pounds gauge pressure?

A single cylinder motor of 6-inch bore and  $6\frac{1}{2}$ -inch stroke should develop 9 horsepower at 600 revolutions per minute. For a compression of 60 pounds, gauge pressure, the clearance in the combustion chamber should be about  $1\frac{1}{2}$  inches.

At what speed should a motor of  $4\frac{1}{2}$ -inch bore and stroke run to develop 6 actual horsepower, and what should be the diameter and weight of the rim of the fly wheel?

A motor of  $4\frac{1}{2}$ -inch bore and stroke will develop 6 actual horsepower at 960 revolutions per minute. The diameter of the fly wheel should be 14 inches and the weight of the rim about 65 to 70 pounds.

What horsepower should a single-cylinder, two-piston motor develop, with 6-inch bore and 5-inch stroke for each piston, making a total stroke of 10 inches?—G. L.

At 500 revolutions per minute such a motor should develop at least 12 horsepower.

What horsepower should a motor of 5-inch bore and 6-inch stroke develop at 600 revolutions per minute with 65 pounds compression, gauge pressure?—J. B.

A motor of 5-inch bore and 6-inch stroke at 600 revolutions per minute, with 65 pounds compression, should develop 6 horsepower.

## AND HOW TO CURE THEM.

### Miscellaneous.

**REPAIR OF CRACKED WATER JACKETS.**—In the course of a paper recently read before the French Society of Civil Engineers M. Jules Garnier described a method by which he repaired the jacket of his automobile cylinder, the water in which froze and cracked the outside casing. The author states that he has cemented wide cracks with a composition of sulphur, iron filings and salammoniac, but in the present case the crack was not open enough to allow the introduction of anything but a liquid, which led to the idea of utilizing the property which the copper salts have of depositing metallic copper when in contact with metallic iron. The cylinder jacket had two openings for the circulation of the water. The cylinders being placed vertically over a zinc basin, the lower opening was closed by a cork and the jacket filled with a slightly concentrated solution of sulphate of copper, through the upper opening. The solution leaked out rapidly through the cracks, collecting in the basin, from whence it was poured back into the jacket. The leakage was rapidly reduced to a mere sweating, so that it was sufficient to pour it back every hour. At the end of the day air was pumped back into the jacket, giving considerable pressure on the liquid. This slightly increased the sweating, but as the extruded liquid was nearly colorless instead of being blue, it was obvious that the operation was nearly complete, and on the next day the cracks were perfectly tight and the cylinders were mounted and used.—*Mechanical Engineer.*

**COLD WEATHER TROUBLES.**—If trouble is experienced in cold weather after carriage has been standing long, an oiler containing gasolene should be used to inject a charge into the cylinders through the pet cocks, to aid in starting (see cut of engine); also open the gasolene valve (that is the valve with the winged nut in middle of seat) about one-fourth turn. Gasolene valve must be turned back to its original position, however, as soon as motor begins to warm up.

In cold weather, calcium chloride should be used to keep water from freezing, and this should always be kept in carriage when temperature is below freezing. Five pounds to the gallon of water, or thirty pounds to the carriage, is sufficient for weather as cold as fifteen degrees below zero.

## DISEASES OF A GASOLENE AUTOMOBILE

### HOW TO PREVENT WHISTLING IN MIXING TUBES for Steam

**Auto.**—Editor HORSELESS AGE: I notice on page 698 of the HORSELESS AGE a query by Wetherbee Brothers as to what causes the whistling at the mixing tube of burners. I have found that in some cases the cause is that the nozzle is not in line with the centre of the mixing tube. By experimenting and varying the space between the nozzle and the mixing tube the whistling can be stopped. If the flare of the mixing tube is large, the space between the tube and the nozzle must be less. In one carriage the only way I could stop the whistling was by sawing four notches through the flaring part of the tube.

### REMEDYING SCRATCHED CYLINDERS.—Muskegon, Mich.—

Editor MOTOR AGE—I read some time ago in *Motor Age* how some one had fixed a scratched cylinder by putting something in the scratches to fill them up. There are a few scratches in the cylinder of my gasoline motor, and the compression is consequently very poor. How can the cylinder be fixed so as to avoid reboring it?—C. J. D.

The cylinder may be temporarily fixed by taking it to a first-class tin-smith and having the scratches filled with silver solder. The soldered places must be then carefully scraped flush with the bore of the cylinder. The best way is to have the cylinder rebored and the piston rings re-turned.

**SOLDERING COPPER TO ALUMINUM.**—I have some copper-pipes which I wish to solder to some aluminum fittings on a gasoline motor; can you give me a recipe or formula for a reliable aluminum solder?

The following formula is said to be one of the best for the purpose: It consists of one part chemically pure lead, ten parts cadmium, ten parts tin and ten parts zinc. The parts to be soldered must first be put in a saturated solution of hypo-sulphite of soda for about two hours.

**A GOOD SOLDER FOR ALUMINUM** can be made as follows: Tin, 10 parts; cadmium, 10 parts; lead, 1 part; zinc, 10 parts. Treat the parts to be soldered in a bath of a solution of hyposulphate of soda for about one hour before soldering.

**STRAIGHTENING CRANK SHAFT.**—Chicago—Editor MOTOR AGE—By the breaking of a connecting rod the crank shaft of my four-cylinder vertical automobile motor has been badly

## AND HOW TO CURE THEM.

sprung, also the lower half of the crank chamber, which is of aluminum, has been badly cracked from the same cause. Can the crank shaft be straightened so as to make it usable or will a new crank shaft be necessary? What is the best method of fixing the crank in the crank chamber? Can it be brazed?—G. F. H.

The crank shaft might be straightened by an expert mechanic, but the journal and crank pin would have to be returned and new bearings fitted to all of them. This would make almost as expensive a proposition as a new crank shaft, which would be the best job of the two. The crank shaft would also be reduced in strength by re-turning the journals and crank pins. The best method of repairing the crank chamber is to put a patch of soft sheet iron about 3-64 of an inch thick on the crack and inside the crank chamber if possible. Before riveting the patch in place, a strip of coarse canvas thickly covered with white or red lead should be placed under the sheet iron patch. The patch should be temporarily bolted in place while riveting and  $\frac{1}{8}$ -inch soft steel rivets used. The rivet holes in the crank chamber, if the patch is put on the inside, should be countersunk on the outside of the crank chamber and hot rivets used. It is impossible to braze aluminum.

**REBORING SCRATCHED CYLINDER.**—Rye, N. Y.—Editor  
**MOTOR AGE**—The wrist pin in the piston of my  $4\frac{1}{2}$ -horsepower gasolene motor having worked loose in some unaccountable manner and scratched the cylinder very badly in several places, at diametrically opposite points, the motor will not hold the compression for an instant. Is there any way in which this damage can be remedied without getting a new cylinder and piston?—A. B.

If the scratches are not too deep the cylinder can be rebored, and a new set of piston rings made to fit the new bore. The limit to such an increase in bore is about 1-32 of an inch in small motors.

**GASOLENE ENGINES IN HIGH ALTITUDES.**—Editor **HORSELESS AGE**:—We hand you herewith New York draft for \$3 to pay one year's subscription to your valuable paper. Have been a regular subscriber for several years and consider its policy a fearless and aggressive one that will advance the

## DISEASES OF A GASOLENE AUTOMOBILE

interests of the whole automobile industry. We like the articles that appear in it from week to week. They show that at least some of the writers have "been there."

We are 2,100 feet above the sea level and the article from Colorado in regard to the rarefied atmosphere and its effect on the working of a gasolene engine recalls our experience. We find that the valves as marked at the factory will not give the proper mixture on at least more than a dozen engines, when operated at this place.

Have had some experience with autos and think the best way for one to familiarize himself with one is to make the motor, transmission and the gear. He then will have the construction well instilled into his mind. To be sure, everyone cannot do this, but think anyone who can will be well paid who will do so.—M. E. CARLEY.

**REFITTING PISTON RINGS.**—Jackson, Mich.—Editor MOTOR AGE—The cylinder of my 4½-horsepower motor having become badly worn and somewhat scratched, I had a new set of piston rings made; but instead of improving matters the new piston rings seem to have made things worse, and motor has scarcely any compression at all. Can you give me any help in this matter?—C. R.

Fitting new piston rings to a worn cylinder would certainly make matters worse, as the old rings had worn to the shape of the cylinder. The cylinder should be rebored and a set of piston rings made to fit the new bore.

**MATERIALS FOR MOTOR VALVES.**—Minneapolis, Minn.—Editor MOTOR AGE—What is the best material from which to make inlet and exhaust valves?—F. C.

Small valves are usually made of a high grade steel and the heads hardened. Nickel steel is also used for this purpose. For valves of large diameter, cast iron heads are to be preferred, as it has been found that cast iron resists the corrosive action of the burning gases better than other metals.

**EFFECT OF ALTITUDE ON GASOLENE ENGINES.**—Editor HORSELESS AGE.—At an altitude of 8,000 to 9,000 feet above the sea level what effect would the rarefaction of the air have on the operation of a gasolene motor? As we have here (Calif-



## AND HOW TO CURE THEM.

fornia) a zero and under temperature in winter it would be difficult to use steam.

E. R. BROOKS, M. D.

[At an altitude of 8,500 feet the atmospheric pressure is only 10.6 pounds per square inch instead of 14.7 as at sea level. If the compression is kept constant the power will be reduced in the same proportion—i. e., about 25 per cent. If, however, no changes are made in the compression space of the engine the reduction of power will be still greater. It will be advisable to reduce the compression space of the engine by 25 per cent., so that the compression at that altitude will be the same as it would otherwise be at near the sea level.—Ed.]

**SHOWING GASOLENE is NOT DANGEROUS.**—In a recent English law suit some remarkable evidence was given in respect to experiments that have recently been made with gasolene. The plaintiff claimed that a lighted cigarette had caused the ignition of some gasolene while this was being poured into the tank of a motor bicycle, resulting in the destruction of the bicycle.

The experiments, conducted by the Booth Cycle, Motor & Engineering Co., of London, were as follows:

1. A lighted match placed at the opening of a new 2-gallon can of gasoline merely caused a small flame an inch long, which could be extinguished with the point of a finger.

2. Gasolene was then poured into an open vessel and a lighted cigarette dropped into it. Result: It was at once extinguished.

3. A lighted cigarette was then smoked vigorously from within two feet above to a quarter of an inch of the gasolene; also all around and underneath the vessel, but no ignition occurred.

4. A small quantity of gasolene was then poured on the cigarette while still smoking; still no ignition occurred.

5. A case was then made hot, and the gasolene poured into it, so that it would vaporize more quickly; a lighted cigarette was then smoked into it, as in case No. 3, but failed to cause ignition.

**IGNITION METHOD.**—Princeton, Ill.—Editor MOTOR AGE—As a reader of your valuable paper I would like to ask a question.

## DISEASES OF A GASOLENE AUTOMOBILE

Is there any way other than the electric spark or hot tube to ignite the charge in gas or gasoline engines? If there is, please inform me as to how they work or what they are.—E. L. TRIMMER.

There are two other methods of ignition, but they are not much used. The first is what is known as catalytic ignition, in which a small piece of spongy platinum is rendered incandescent by the heat of the combustion of the charge. The second is the form employed in the Diesel type of gas engine, in which the compression is carried to such a degree as to cause spontaneous combustion, or self-ignition, from the heat generated during the compression of the charge.

**IGNITION POINT FOR HILL CLIMBING.**—Seattle, Wash.—Editor **MOTOR AGE.**—Which gives the cooler mixture, much or little air? Should the ignition be retarded or advanced when going up a grade?—R. P.

The more air used, up to the limitation of the explosive proportions, the cooler the mixture will be but the explosions will also be weaker or less violent. The ignition should always be retarded on going up a grade, especially if the motor is being worked to its full capacity. When the motor is working hard the back pressure induced by early ignition will tend to lower its efficiency.

**"WILL GASOLENE EXPLODE?"**—Editor **HORSELESS AGE.**—Will gasoline explode? This question, I believe, has been answered by various experts, yourselves included, in the negative; yet I enclose an article from an off-color New York paper, which states and reiterates that in the course of the destruction of the De Witt gasoline car yesterday there were explosions—explosions that detonated, that fractured numerous plate glass windows, that were heard a mile away, and that sent sheets of flame in all directions to a considerable radius. This would seem to place the question squarely up to "us," and if we have been deluding ourselves on this important subject it should be the duty of a progressive automobile organ to let the fact be known, and in such exact detail that there can be no possible misconception of the dangers as well as the safety to be looked for in the handling of automobiles. I have been delighted with the repeated assurances of safety, but I do not wish to be

## AND HOW TO CURE THEM.

lulled into forgetfulness or carelessness by false information on this point, because I fear the awakening may be too abrupt. In other words, we want to know—and must know—exactly what the conditions are under which gasolene will explode, so that these conditions may be avoided.—C. H. INGERSOLL.

**GASOLENE "EXPLOSIONS."**—In a recent editorial, "Gasolene Not an Explosive," we pointed out some of the important differences between the former and the common explosives, such as gunpowder. The subject was not gone into as thoroughly as its importance warrants, and as a rather serious accident in this city during the past week has lent additional interest to the theme, it may properly be further discussed.

There are two entirely different kinds of explosion, which in the public press would undoubtedly both be referred to as "gasolene" explosions. The real gasolene explosion is the kind taking place in the cylinder of a gasolene engine, in which heat and pressure are suddenly produced by the combustion of gasolene vapor in air. The other kind of explosion referred to may be explained as follows:

Suppose a tank of gasolene placed on a woodpile and the latter set on fire. The heat would raise a pressure in the tank, which, in a strong fire, would rapidly increase and the tank would finally explode. The gasolene would then be thrown in all directions, and, owing to its superheated condition, the greater part of it at least would instantly vaporize, mix with the air of the atmosphere and be ignited by the flame which caused the explosion.

The kind of explosion here described is therefore caused by heat being imparted to gasolene in a tank from an outside source; it is properly called a tank explosion. Gasolene explosion in this case would be as inappropriate a term as "water" explosion for steam boiler explosion.

In the winter put glycerine and bicarbonate of soda in the water. The portion of glycerine is  $\frac{1}{3}$  to water and  $\frac{1}{15}$  of bicarbonate of soda.

The last described kind of explosion is not altogether impossible in automobiles, and the accident to the De Witt automobile in New York city last week may have been of this nature. In most touring cars the gasolene tanks are located in

## DISEASES OF A GASOLENE AUTOMOBILE

the front seat, and are therefore surrounded by combustible material. The car in question, it appears, had a leak in the gasolene system, and a pool of gasolene had collected on the street where it stood. The vapors from this gasolene were accidentally ignited, and the heat developed by this fire (sustained probably both by the gasolene on the street and the wood-work of the body) generated such a pressure in the gasolene tank that it exploded. Such an explosion might have enough force to tear the machine to pieces and cause the serious damage recorded in the reports of the accident.

The moral of this accident is obvious. It is very difficult to set a carriage body on fire unless gasolene has been spilled over it or a pool of gasolene has collected on the ground below it and ignited. The important point is to avoid the spilling or leakage of gasolene. Accidents of this kind to gasolene automobiles are on the whole of very infrequent occurrence, yet the serious character they may assume requires that every possible precaution be taken against them. The gasolene tank should be located in a well protected place, as far away from the hot parts of the engine as possible, even though this may require longer piping. The connections should be thoroughly secure and be inspected regularly.

**SPARK WANTED.**—St. Louis, Mo.—Editor **MOTOR AGE**—I would like to know what is wrong with the electric ignition on my motor bicycle. The primary circuit is in good shape and sparks at every contact; the secondary circuit sparks once in a while only, but when it does it gives a good spark. This of course, causes misfiring in the motor cylinder.—S. W.

The probable cause of the trouble is either that the battery is run down or that the secondary winding of the coil has become disrupted from some cause or other. Try a new battery, and if this does not remedy the trouble the difficulty lies in the secondary winding of the coil.

**ADVANTAGES OF VIBRATOR COIL.**—Newport, R. I.—Editor **MOTOR AGE**—Is a vibrator coil to be preferred to a plain jump spark coil, and will a vibrator coil increase the power of a motor?—K. G.

A vibrator coil will give better firing results than a plain coil, at it will cause a stream or succession of sparks at the plug,

## AND HOW TO CURE THEM.

instead of only a single spark, as with the plain coil. As the intensity of the spark produced by a vibrator coil is far greater than that of the plain coil, the time or period of ignition is less, and the motor speed is consequently increased, thereby increasing the horsepower of the motor.

### **CURRENT USED WITH VIBRATOR COIL.**—Boston, Mass.—

Editor **MOTOR AGE**—Which uses the most battery current, a plain jump spark coil or a vibrator coil? As the commutator used with a vibrator coil generally has a longer period of contact than has the contact maker of a plain jump spark coil, it would be naturally supposed that the vibrator type of coil would use the most battery current.—P. G.

A properly designed vibrator coil will not use as much current as a plain jump spark coil. The self-induction in the primary circuit caused by the high frequency of the pulsations tends to check the flow of the current to a far greater extent in a vibrator coil than in a plain jump spark coil. The amount of the retardation of the current in the primary winding of a vibrator coil can be calculated to a nicety, when the number of pulsations of the coil per second are known, but this calculation involves the use of logarithms and a knowledge of higher mathematics.

**PLATINUM CONTACT POINTS.**—Having had a great deal of trouble with the ignition mechanism of my automobile motor, I removed the spring contact-breaker and screw and took them to a jeweler, who examined the contact points and said that they were German silver. Should not these contact points be made of platinum? Where can it be obtained?

The contact points should by all means be of platinum. Iridio-platinum is better still. Either can be obtained from any large wholesale dental house, or from most automobile supply houses.

**DIFFERENT FORMS OF COILS.**—I would like to know the difference between the trembler form of induction coil and the plain jump spark form. What advantage has the former over the latter, if any?

In the trembler form of coil the contact is made and broken in the primary circuit a great many times during the period of ignition. The result is a stream of sparks of great intensity.

## DISEASES OF A GASOLENE AUTOMOBILE

In the plain jump spark coil only a single make and break occurs during the period of ignition, which gives only a single jump spark. The trembler form of coil requires more care and attention than the plain jump spark coil, and manufacturers and users of coils are divided in opinion as to which is the best form. If properly cared for, the trembler form should certainly give first-class results.

**POOR SECONDARY INSULATION.**—The secondary wires of my gasoline automobile motor are of common weather proof wire and having become saturated with oil from the motor, seem to cause the motor to work poorly, as it mis-fires badly. How can this defect be remedied? I have tried covering the wires with sticky tape, but it does not seem to make much improvement.

The secondary wiring should be replaced throughout with new wire and every portion covered with pure rubber tubing, which may be obtained at any electrical supply house. On no account use common gas hose in place of the pure rubber tubing. It is just a little better than nothing.

**TESTING IGNITION BATTERIES.**—Which is the proper instrument to use for testing batteries, a volt meter or an ampere meter? I have been told that it will injure an ampere meter if it is put in a battery circuit.

A pocket ampere meter should be used for testing dry batteries, as a dry battery will show up almost its full voltage and still be practically exhausted. Storage batteries should always be tested with a small volt meter; using an ampere meter in the circuit will not in the least injure the ampere meter, but it is bad practice to put a storage battery on a short circuit even for an indefinitely short length of time. An ampere meter is made to measure the strength of an electric current and if used within the limit of its rated capacity, no harm can be done it by leaving it in an electrical circuit indefinitely, as is the case when charging storage batteries.

**THE IGNITION QUESTION.**—There is a liability of troubles with the ignition system, but these can be made very few by an intelligent oversight. I have had little trouble so far with my dry batteries, and they have probably given me less bother and been a source of less expense than a dynamo would have. The carriage came with a set of dry batteries sealed up in a

## AND HOW TO CURE THEM.

box. I got about 1,100 miles of service without a miss, till one day, when coming out after making a call, I could not start the carriage. Testing the spark I found it practically absent. Taking the electric cars to the nearest bicycle shop I found a battery of four dry cells. I cut out the old and slipped in the new cells, and off we went as merrily as ever. Now after 600 miles of use the cells test ten amperes. This cost me \$1 to replace. While I can run my carriage for this amount I shall not investigate the unknown merits of a dynamo. If I had been more experienced I might have foreseen that my batteries were about to run out, and would have kept an extra set with me for an emergency.

**COMPARATIVE IGNITION TROUBLES.**—Why do batteries and ignition devices used on gasolene automobiles give so much more trouble than those used on stationary gas and gasolene engines? Would hot tub ignition be practicable on an automobile?

The principal reason for the troubles experienced with batteries and ignition devices on gasolene automobiles is from the exceedingly high speeds at which such motors are run and the greater amount of heat developed as compared with stationary gas or gasolene engines.

Hot tube ignition has been used on gasolene automobile motors, but as this form of ignition does not allow the motor speed to be regulated it was discarded in favor of electric ignition.

**DISPOSITION OF PISTON RINGS.**—Which is the better construction, to put four piston rings on the piston of a gasolene automobile motor in two pairs—that is two rings in one slot—or to put each of the four piston rings in a separate slot.

It is by all means the better construction to put each of the four piston rings in a separate slot. This construction is nearly always used in stationary gas and gasolene engine practice and such engines carry much higher compression than gasolene automobile motors.

**FULL CHARGE OF FUEL.**—I have a float feed carburetter of French make fitted to my 10-horse power, two-cylinder motor, and if I try to run the motor with the throttle in the inlet pipe full open, the motor will either stop altogether or not develop as much power

## DISEASES OF A GASOLENE AUTOMOBILE

as it does with the throttle about three-quarters of the way open. There is no way to regulate the quantity of gasoline fed to the nozzle of the carburetter. The nozzle has a small hole in it about 1-32 of an inch in diameter. What is the cause of this trouble and can you suggest any remedy for it?

The probable cause of the trouble must be in the fact that the hole in the nozzle does not supply the quantity of gasoline which is necessary when a full supply of air is taken into the carburetter, to produce a highly explosive mixture; thereby causing weak explosives or mis-firing when the throttle is full open. The nozzle should be removed from the carburetter and the hole drilled larger. A little experimenting may be necessary to get the right size of hole as it is not good policy to enlarge the hole too much the first time.

**A CORRESPONDENT WRITES.**—I took the motor apart and found the rings did not fit the grooves in the piston. I trued up the grooves and made new rings and ground them into the grooves; then put the piston into the cylinder and ground the rings to a good fit in the cylinder. The result was a good compression, and a motor that would climb a fairly steep hill.

I balanced the motor by drilling into the flywheels. Then I made a new vaporizer, with a throttle, the gasoline being regulated by a small needle valve—that is, the amount getting to the vaporizer. The air passed through a check valve which contained in its centre a small needle valve, having one sixty-fourth of an inch play, which allowed the main valve to lift slightly.

**TESTING SMALL BATTERY.**—What is the best method of testing a small storage battery of two cells to find out if it is fully charged.

Get a 4-volt, 1-ampere incandescent lamp, and after cutting the battery out of the charging current, put the lamp in circuit with the battery for a few seconds only. If the battery is fully charged the lamp will give out a brilliant light. On no account use a pocket ammeter to test a storage battery; it will injure the battery if kept in the circuit long enough to get an accurate reading.



## AND HOW TO CURE THEM.

**IRREGULARLY RUNNING MOTOR.**—I have a 4½ horse power gasoline motor which seems to have suddenly lost most of its power and will hardly drive the car. I have examined the cylinder, piston and piston rings and find all in good condition. The valves are a nice fit on their seats and the compression is good. The storage battery which is used for the ignition has been overhauled and the timing of the ignition is correct. The motor does not miss fire, but runs unevenly with but little power and in jerks—sometimes almost stopping and the next minute racing like mad. I will be much obliged if you can suggest the cause of this trouble.

The trouble described is probably due to one of two things. Either something is wrong with the carburetter or there is a loose screw or contact in the ignition mechanism. If the trouble be in the carburetter, it may be that the float is too light or that the needle valve opening is not sufficiently large. All connections from the coil and battery to the motor should be inspected and properly tightened.

**MAKING A LAUNCH MOTOR RUN.**—A few days ago I was called upon by a friend of mine to find out what was wrong with his gasoline motor launch, the motor of which had positively refused to work since the day he got it. Upon arriving at the scene of the trouble, the boat was found to be a 16-footer and equipped with a vertical, four-cylinder motor of 10 horsepower and with an 18-inch, double-blade propeller of the reversible or feathering type.

An investigation showed that the four secondary wires leading to the spark plugs were of ordinary light circuit wire and without any other insulation, and were carried in a brass tube, supported by two small brackets attached to the cylinder heads. As a pier in the lake was not a very fruitful source of supplies, the handle of a broom was impressed into service and a piece of the required length cut off and fastened to the small brackets in place of the brass tubing. The secondary wires were then fastened to this improvised insulator or non-conductor, so that there was no chance of leakage between them or of a ground to the motor, which without doubt existed in the case of the brass tube, which was fitted before.

## DISEASES OF A GASOLENE AUTOMOBILE

The ignition mechanism was next inspected, and the commutator was found to be so set that the point of early ignition was slightly after the pistons had passed their upper dead-centers and were on their downward strokes, the points of late ignition being nearly one-third of the way out on the downward strokes of the pistons. After the timing of the ignition had been properly adjusted and the wiring from the quadruple coil to the motor and batteries put in shape, the motor was started, the propeller thrown in gear and the 16-footer went out into the lake at an 8-knot gait—so fast indeed that as there was quite a swell on, the boat shipped more water than the bilge pump could take care of and consequently made fast running dangerous.

A local expert who had been also called upon to put the motor in shape had said that the only thing wrong was that the batteries were as good.

**PUTTING IN MUFFLER CUT-OUT.**—I would like to know how to attach a muffler cut-out to my gasoline machine? It is of the vertical, two-cylinder type, with the muffler and exhaust pipe connected similarly to the method used on the French machines.

A three-way cock may be put in the exhaust pipe at any suitable point between the motor and muffler; or a tee connection with the nipple and butterfly valve. Either of these devices may be operated from the seat by means of a rod and lever attachment to the stem of the cock or valve.

**DEFECTIVE IGNITION.**—The gasoline motor of my automobile fires regularly when the ignition mechanism is retarded, but when fully advanced the motor will not fire at all, and when partially advanced fires irregularly. Can you kindly tell me the cause of this trouble, and how to remedy it.

The cause is most probably due to weak or run-down batteries. Test with a new set of cells. If the trouble is not then overcome, it may be due to defective insulation of the spark plug; or the platinum points may be either too far apart or corroded. Take the spark plug apart and examine it closely and clean the platinum points thoroughly and set  $1/32$  of an inch apart.

## AND HOW TO CURE THEM.

**CONNECTING TERMINALS.**—I have a vibrator coil of French make which has three terminals, marked P, C and B. Can you inform me how to connect this coil with the battery and motor?

The terminal of the coil marked P should be connected with one of the battery terminals; the one marked C with the insulated contact maker on the motor, and the one marked B with the spark plug. The other terminal of the battery should be connected through a switch with a ground on the motor.

**CORRODED CONTACT POINTS.**—The contact maker of the ignition mechanism of my gasolene motor corrodes badly at the platinum points. Can you tell me the cause of this trouble and suggest any remedy for it?

Either too many cells of battery are being used, or the resistance of the primary winding of the coil is too small. A small resistance coil made of about 18 inches No. 18 B. and S. gauge German silver wire and wound in an open coil, if put in the primary circuit, might decrease the trouble.

**Sometimes a leaky gasolene tank** is caused by a galvanic action taking place between the copper rivets and the zinc on the galvanized iron. Copper or brass tanks should always be riveted with copper rivets and iron tanks with iron rivets.

**TESTING IGNITION BATTERY.**—How can I tell when a small storage battery that is used for ignition purposes is fully charged? After charging I tested with a pocket voltmeter and it showed nearly 4 volts, yet only ran the machine about 25 miles, instead of 500 miles, which it usually does without difficulty?

A volt meter is not suitable to test a storage battery to ascertain whether charged or not. A small pocket ammeter should be used for this purpose. A loose or corroded terminal might be the cause of the trouble and prevent the battery from being fully charged.

**CHANGE IN IGNITION SYSTEM.**—I have an 8-horsepower gasolene motor which is fitted with an ignition mechanism of the make and break type. Could I have the ignition system changed so as to use a jumpspark and a vibrator coil and will I get any better results from the motor?

## DISEASES OF A GASOLINE AUTOMOBILE

The jump spark form of ignition could be fitted to the motor by any competent automobile mechanic without trouble. The jump spark will enable the motor to be run at a higher rate of speed and consequently increase its efficiency.

**FORMS OF ELECTRICITY.**—Is the electricity generated by a magneto or dynamo the same kind as that supplied by a storage or dry battery.

Electricity or electrical energy can be generated in several ways—mechanically, chemically and statically or frictionally. By whichever means it is produced, there are many properties common to all. There are also distinctive properties. The current supplied by a storage battery will flow continuously until the battery is exhausted; while the current from a dry battery can only be used intermittently—that is, it must have slight periods of rest, no matter how small.

The magneto or dynamo current is of an alternating nature, or one which reverses its direction rapidly. In use it is changed into a current flowing in one direction only, by means of a commutator. Any of the three methods are capable of exploding or firing a charge of gas and air in a motor cylinder, but static electricity is not employed for this purpose on account of its erratic nature.

## AND HOW TO CURE THEM.

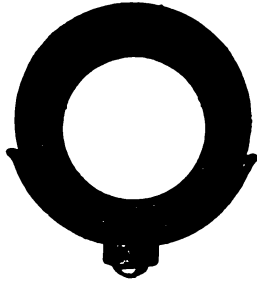

### TIRES.

**TIRES.**—Single Tube Tires are fast being discarded for Double Tube Tires. A **Single Tube Tire**, some say, can never be repaired so that it will not leak. The fabric seems to be the difficult part to repair, and when the rubber is patched on each side of the fabric, it soon gives way and leaks. See what the Diamond Concern say:

**THE DIAMOND REPAIR OUTFIT** is the result of lengthy experiment and exhaustive tests. It practically and successfully combats every statement to the effect that **Single Tube Automobile Tires** cannot be repaired on the road. This argument is the only one that has ever been made derogatory to this type of tire. **Punctures, Cuts** and injuries of like nature can be repaired successfully.

## DISEASES OF A GASOLENE AUTOMOBILE



**THE OUTFIT COMPLETE** (Except the Box).—Parts: Inserting Tool, Jiffy Tool (6 oz.), Half-round Rubber (3 ft.), Cement ( $\frac{1}{4}$  pt. can), Friction Tape (1 oz.). The Jiffy Tool and Electric Tape only for use in case of emergency.

## AND HOW TO CURE THEM.

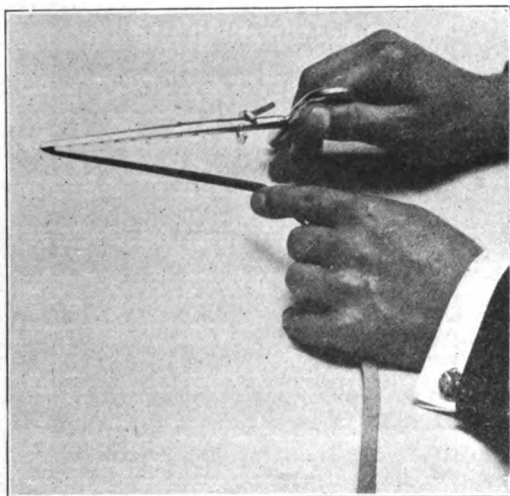

**ATTACHING RUBBER TO INSERTING TOOL.**—Place one end of rubber cord under clamp (as shown in cut), draw rubber taut and pass over notched end of tool and then under clamp on reverse side. Be sure rubber is placed between points on notched end, so that tool can be forced into puncture easily. It is also necessary that rubber be drawn as tight as possible, to secure minimum diameter.

## DISEASES OF A GASOLENE AUTOMOBILE

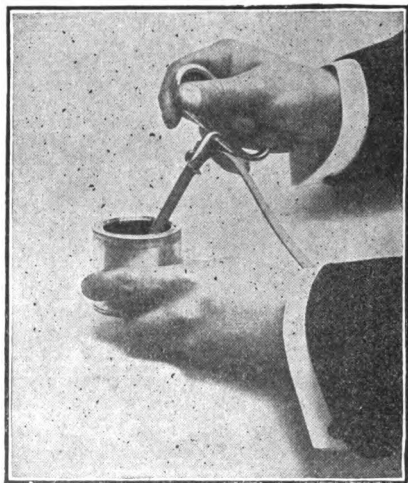

**COATING RUBBER AND TOOL WITH CEMENT.**—Remove the cover from cement can and lubricate rubber and tool thoroughly, as shown in cut. See that the depressions on sides of inserting tool are thoroughly covered, in order to withdraw tool readily without disturbing the rubber. This also permits of the flat sides of the cord cementing together after rubber has adjusted itself to the shape of the cut or puncture.



## AND HOW TO CURE THEM.

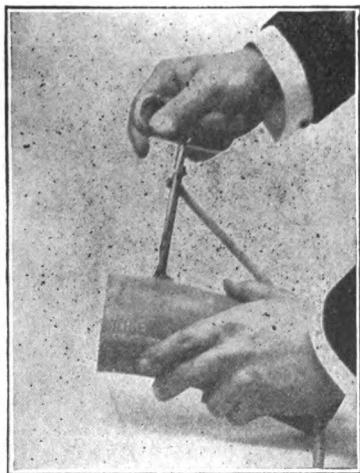

**INSERTING RUBBER IN PUNCTURE.**— After lubricating rubber thoroughly, force tool into puncture, forcing in and out several times to thoroughly cover the sides of the puncture with cement. On last stroke, force tool into tire so that clamps come about two inches from outside of tire. Then release rubber by drawing clamps toward you. It immediately expands, adjusting itself to the shape of the cut or puncture and positively closes it.

## DISEASES OF A GASOLENE AUTOMOBILE

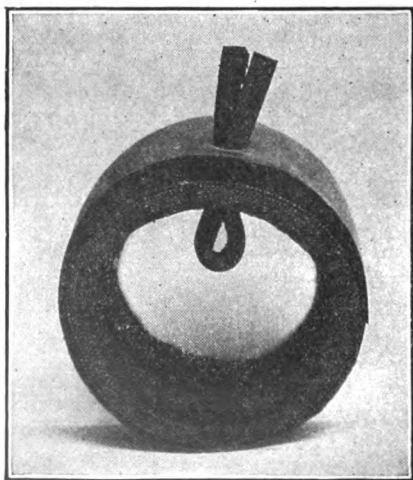

**THE RESULT—It's Positive.** All that is now necessary is to trim rubber on outside of tire and the job is finished.

**AND HOW TO CURE THEM.**

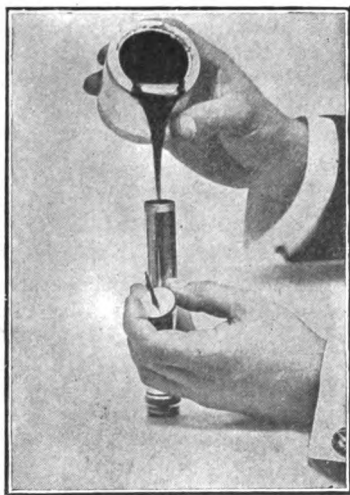

**Loading Jiffy Tool.**

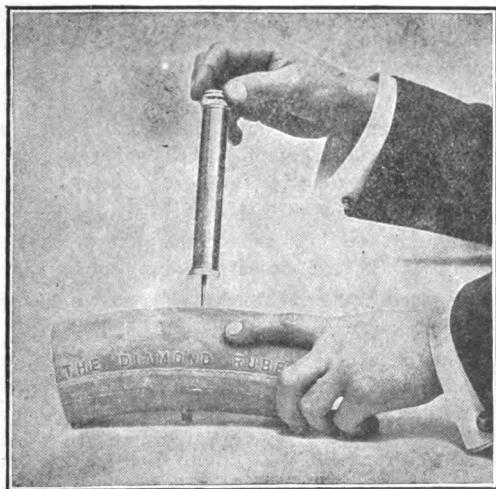

**Closing Small Punctures.**

## DISEASES OF A GASOLENE AUTOMOBILE

**DIRECTIONS FOR USING JIFFY TOOL TO CLOSE MINUTE PUNCTURES.**—Cuts on opposite page show how Jiffy Tool is used. This method should only be used in cases where punctures are exceptionally small. Cut on page ? shows all parts of this instrument; the plunger working up and down on the piston by simply turning thumb screw, thereby exerting a direct pressure on the cement. Care should be taken to see that point of tool is forced into tires its entire length, thus insuring proper placing of cement on inner wall.

**A FEW SUGGESTIONS.**—It is clear that a close relationship must exist between the Automobile manufacturer, driver and tire maker, in order to get the most economy. Our repair stations report failures of tire chiefly due to drivers becoming careless of the air pressure—insufficient as a rule—driving fast over rough places, striking stones, thus rupturing the fabric. Also using tires which have been ruptured or punctured. A tire cannot be ridden deflated any great distance without serious consequences.

**Therefore:** Never ride tires without inflating so that tires stand up round under full load in motion. Every owner should possess a large pump, Dykes No 1 being a good one. Do not inflate tires with pump used to pump gasoline, and keep gasoline off the tires.

Avoid large stones or obstructions, because a sharp blow ruptures the fabric and the tire looks to all appearances like a porous tire. A porous Diamond Tire is never delivered, because rigid inspection will discover it before delivery.

We particularly caution you that in using your Automobile during summer months to reduce the pressure in the tires, for the reason that the heat increases the pressure in the tires.

See that tires are cemented to rims as well as fastened by lugs. Shellac is preferable.

There is no hard or fast rule. Good care and judgment will guide. In case of an injury which cannot be repaired with the Diamond Repair Outfit, return the tires to the most convenient of our repair stations, prepaying transportation charges, and tag same with your name and address, following shipment with letter.

## AND HOW TO CURE THEM.

**DOUBLE TUBE TIRES** seem to be the tire most in demand. The inner tube, which is made of all rubber and no fabric, can easily be repaired. The illustration shows method of repairing the G. & J. Double Tube Tire.



**HANDLING AND REPAIRING.**—It is well to carry an extra inner tube to place in the outer case should a tire be punctured. This plan is usually more satisfactory than to make repairs on the road. When a tire is punctured the tube should be repaired or replaced immediately. The inner tube will be ruined if the tire is ridden deflated, and the outer case may also be badly damaged.

**TO REMOVE THE TIRE FROM THE RIM**—Have all the air expelled from the tube. Observe that one side of the outer case is lettered thus: "Apply this edge last and remove it first." The side of the case bearing this lettering should always be on the outside, away from the vehicle, to facilitate handling the tire in making repairs. With one hand push the top of the tire away from you, as shown in Fig. 1, and insert a tool back of the clincher, loosening it from the rim.

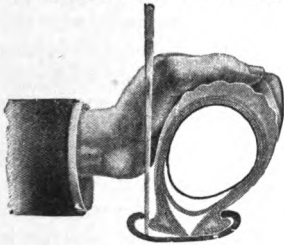

Fig. 1.



The G. & J. Tire tool.

Now take the second tire tool and pry up the edge. With the two tools it will be an easy matter to pry up and release the entire side of the case from the rim. See Figs. 2 and 3.

## DISEASES OF A GASOLENE AUTOMOBILE

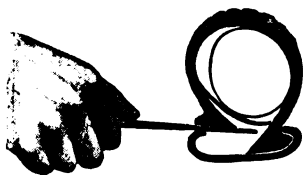

Fig. 2.

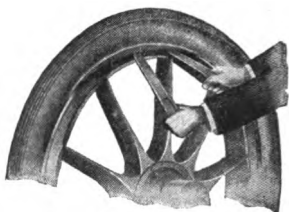

Fig. 3.

If the puncture is located before the tube is removed it will be unnecessary to remove the entire side of the case; one edge of the case may be removed from the rim for a short distance only, when the tube can be drawn down and repaired. See Fig. 4. In an instance of this kind it will be found easier to repair the tube at once than to insert a new tube.

**THE REPAIRING OF A PUNCTURE.**—Sandpaper the surface of the tube where injured until it appears clean and dark. Cut a piece of patching rubber and sandpaper it also. Use a liberal piece of patching rubber, so that there will be a wide margin on all sides of the hole that is to be repaired. Apply a coat of cement to both tube and patch and allow to dry. If time will permit give both tube and patch two coats of cement. When the second coat of cement has become sticky, or "tacky," apply the patch, pressing it down firmly.

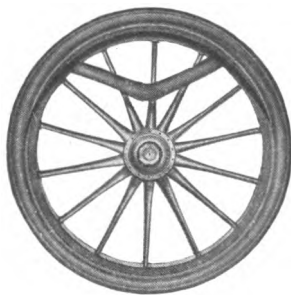

Fig. 4.

Use care in replacing the tube in the case, as there is some danger of opening an air passage under the patch when handling while the cement is fresh.

It will facilitate placing the tire on the rim if the channel of the rim is sprinkled with soapstone. A package

of soapstone will be found in each repair kit.

**TO PLACE THE TIRE ON THE RIM.**—The edge of the case to which the flap is attached must be put in position first, and should be on the inside, next to the vehicle. Place the valve

## AND HOW TO CURE THEM.

hole in the outer case exactly opposite the valve hole in the rim, and, holding the case tightly to the rim, working both ways from the valve hole, slip the clincher into place. It may be necessary to use the tire tools to pry the clincher over the edge of the rim for the last foot or more.

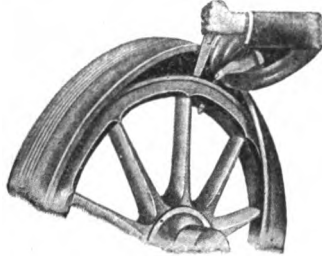

Fig. 5.

With the inner tube entirely deflated, insert the valve in the hole in the rim, laying the tube on top of the flap all the way around, taking care to see that the tube is not twisted.

You are now ready to put the second clincher in place. Start at the valve and put the clincher in place for a distance of about a foot at each side of the valve; then tighten the valve nut. With the two tire tools go around the circumference of the tire, working the clincher in place as shown in Fig. 6, being careful to see that the clincher is underneath the flap all the way around. This part of the work can best be done by working around the tire to the right from the valve, pulling towards you with one tool, thus getting the edge over the rim, using the second tool to force the edge into its seat in the rim.

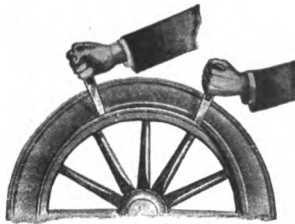

Fig. 6.

Should an outer case be badly cut, it should be bound temporarily with the tire tape supplied in each repair kit. The cut should be vulcanized as soon as possible, before the tire fabric is seriously damaged.

## DISEASES OF A GASOLENE AUTOMOBILE

### POINTS FOR USERS OF VEHICLE TIRES.

**KEEP TIRES WELL INFLATED.**—Your tires will wear much longer and your vehicle will run much lighter if tires are kept well inflated always.

**STARTING AND STOPPING.**—A great strain is brought upon the rear tires of an automobile by quick starts and sudden stops. It is to the advantage of your tires to start and come to a stop gradually.



No. 627.

2½ and 3 inch tires.  
(See next page)

**BEWARE OF OIL.**—In oiling your vehicle be careful not to spill oil on the tires. Oil softens rubber and will render it useless. If oil is accidentally spilled upon a tire it should be removed at once. This can be done with a cloth moistened in benzine.

**THE CARE OF RIMS.**—Rims should be examined occasionally to see that the channel, in which the edges of the tire seat, is not rusting. It is well known that rust will rot the tire fabric. If the rims are rusted, carefully polish the inside and apply two coats of white lead, allowing the first coat to become thoroughly dry before applying the second. When the second coat is quite dry, apply a coat of good varnish to prevent flaking.

**TURNING CORNERS.**—In turning corners at a high rate of speed an excessive strain is thrown upon the outer clinchers of the outside tires. Use moderation in this respect and much better service will be obtained from the tires.



## AND HOW TO CURE THEM.

**G. & J. MOTOR VALVES.**—Prior to January 1, 1903, we used with all sizes of automobile tires a valve having a  $\frac{5}{16}$  inch stem (No. 627). We now supply for use with the  $3\frac{1}{2}$  inch, 4 inch and  $4\frac{1}{2}$  inch tires the Schrader Universal motor valve, having a  $\frac{31}{64}$  inch stem (No. 626). We still supply the No. 627 valve for use with  $2\frac{1}{2}$  and 3 inch tires, as the heavier valve, No. 626, is too large to be used with wood wheels in the smaller sizes, as it would necessitate cutting away entirely too much of the wood felloe.

Orders received from automobile makers for  $3\frac{1}{2}$  inch, 4 inch and  $4\frac{1}{2}$  inch tires will be fitted with the larger valve, but where orders are given for tubes or valves for replacement work, it will be well to always advise which style of valve is required.

Both the No. 626 and No. 627 valves are supplied with long stems for wood wheels or short stems for wire wheels, as desired.

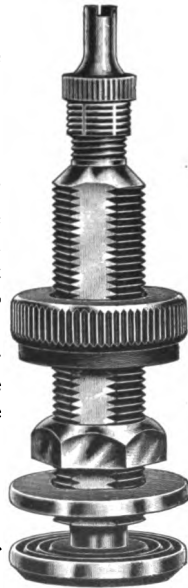

No. 626.

$3\frac{1}{2}$ , 4 and  $4\frac{1}{2}$  in. tires.

DISEASES OF A GASOLENE AUTOMOBILE  
THE GOODYEAR DETACHABLE  
FLANGE TIRE.

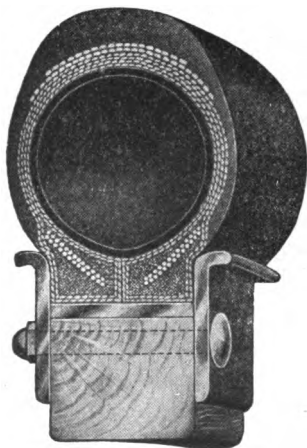

Fig. 1.—Proper Position of Tire when Mounted.

**TO REPAIR THE GOODYEAR DETACHABLE (FLANGE)**

**TIRE.**—This Tire differs from all others and is the easiest tire to repair. The principle of prizing the edge of a cover over a rim is wrong, and this is the cause of so much trouble with Clincher Tires. The edge or bead of a cover is constructed almost wholly of fabric and the latter is not by any means elastic. So that when the edge has been stretched over the rim a number of times, the edge becomes somewhat elongated, and, consequently, is loose and unsafe. The great strain on the beads tends, in time, to cut them along the edge of the rim and thus weakens the tire.

With the Side Flange Tire there are no mushrooms to pinch the air-tube, no tools to punch holes in or pinch the tube, and neither can water find its way in. This type of tire is held absolutely mechanically in place, and is not dependent on air pressure for security in fastenings. The tire is held just as securely on the rim deflated at high speeds as inflated at high speeds, and cannot creep a fraction of an inch, on account of the lateral compression of the base and also on account of

## AND HOW TO CURE THEM.

the bolts that pass through the base of the tire. The fastenings are positive. The air-tube is held secure from harm, in a pocket, as it were, and completely surrounded by the outer cover. No tool can touch it—not necessary. The air-tube is never damaged by a tool. Another great feature is that the

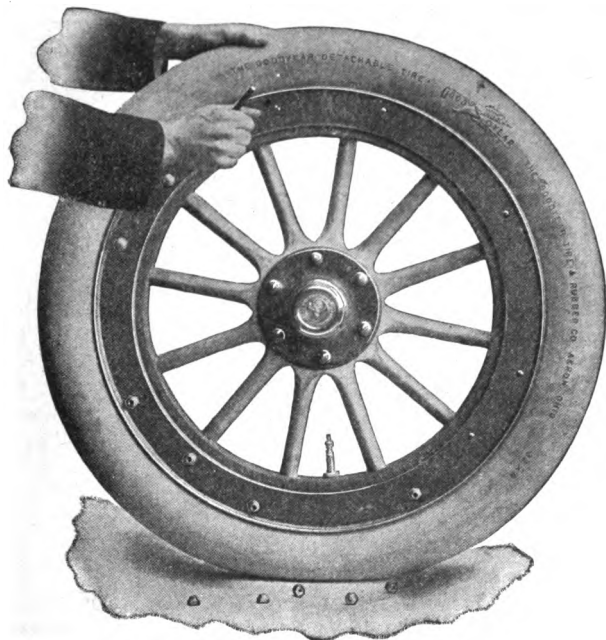

Fig. 2.

flanges greatly strengthen the wheel and prevent a possibility of breakage of the felloe.

**Remove the tire from the wheel:**

(a) Mark the outside flange at the valve and take off all of the nuts with the socket wrench or brace, furnished for this purpose. See Fig. 2. The nuts should always be on the outside of the wheel, never on the inside; it would be unhandy. **Never lay the nuts down on the road or floor—they will get dirty or lost.**

## DISEASES OF A GASOLENE AUTOMOBILE

(b) Remove the outside flange (see Fig. 3). If it has not been removed for some time it may stick slightly to the tire. Prize it away with a screw-driver.

(c) Knock out the bolts that go **through the tire**. Don't lay them down on the ground or floor.



Fig. 3.

(d) Pull the tire toward you, taking hold opposite the valve, so that you do not strain the valve (see Fig. 4). If the wheels are of the proper diameter the tire will slip off the wheel quite readily. (The outside diameter of the wheel should be the same as the inside diameter of the tire.)

## AND HOW TO CURE THEM.



Fig. 4.

(e) Open up the tire with the hands and remove the tube (see Fig. 5). In the event of the tube having become attached to the cover, through overheating by fast running, very careful treatment is required if the tube is to be saved. The parts where the tube is stuck should be brought to the lowest point of the wheel's diameter, and a small quantity of gasolene, or other rubber solvent, should be poured into the cover around the part stuck. In a short time, and by the use of small quantities of solvent, as required, the tube may, bit by bit, be detached from the cover. It is, of course, in a sticky state, and great care should be taken that while freeing one part of the section stuck, another part previously stuck, does not again adhere.

Having freed and removed the tube from the cover, it should be allowed to become quite dry at the places where it has been stuck, before anything more is done with it. When dry, treat

## DISEASES OF A GASOLENE AUTOMOBILE

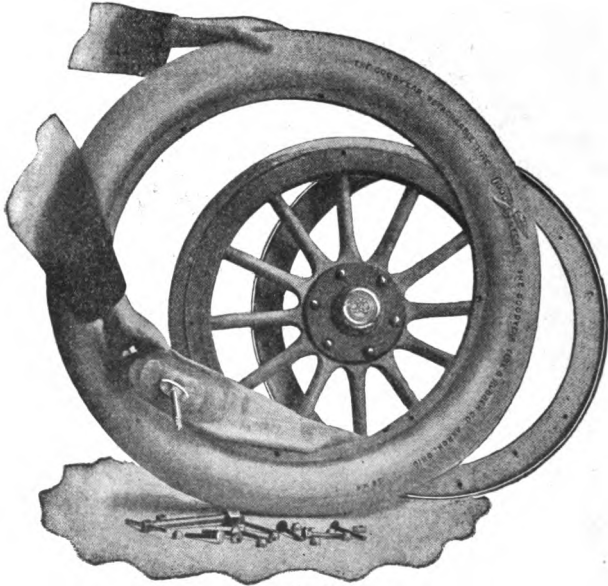

Fig. 5.

to a liberal dose of French chalk, rubbing it well in; at the same time treat the inside of the cover in a similar manner. Under no circumstances should a tire be replaced on a wheel without having both the tube and the inside of the cover well rubbed with French chalk, and a small quantity of it should be left free in the tire. If too much be left in the tire, it will probably form into small, hard pellets, in which case the chalk does more harm than good.

Spare tubes, with valves complete, should be carried in a bag for this purpose, which can be secured from us. A liberal quantity of French chalk should be around the tubes in the bag. The air-tubes should never be allowed to knock about loose with the tools or other spare parts.

(*f*) When the tube has been replaced, and before mounting the tire, inflate the tube just sufficiently to give it a round shape, to prevent it being nipped in the joint of the tire.

(*g*) Replace the tire in exactly the same manner that it was detached.

## AND HOW TO CURE THEM.

### COMPLETE SPECIFICATIONS

of Wheels and Tires.

SIZE OF TIRE	A Outside Diameter of Wheel over Iron Tire	B Thickness of Iron Tire	C Width of Felloe and Iron Tire	D Depth of Felloe and Iron Tire	E No. Bolts through Tire	F No. Bolts through Felloe	
26 x 2½	20½ in.	⅜ in.	1⅜ in.	1¼ in.	.	One for each spoke.	
28 x 2½	22½ in.	⅜ in.	1⅜ in.	1¼ in.	..		
30 x 2½	24½ in.	⅜ in.	1⅜ in.	1¼ in.	..		
32 x 2½	26½ in.	⅜ in.	1⅜ in.	1¼ in.	..		
34 x 2½	28½ in.	⅜ in.	1⅜ in.	1¼ in.	..		
36 x 2½	30½ in.	⅜ in.	1⅜ in.	1¼ in.	..		
26 x 3	19½ in.	⅜ in.	1⅞ in.	1½ in.	..		
28 x 3	21½ in.	⅜ in.	1⅜ in.	1½ in.	..		
30 x 3	23½ in.	⅜ in.	1⅜ in.	1½ in.	..		
32 x 3	25½ in.	⅜ in.	1⅜ in.	1½ in.	..		
34 x 3	27½ in.	⅜ in.	1⅜ in.	1½ in.	..		
36 x 3	29½ in.	⅜ in.	1⅜ in.	1½ in.	..		
28 x 3½	19½ in.	⅜ in.	1⅜ in.	1½ in.	8		4
30 x 3½	21½ in.	⅜ in.	1⅜ in.	1½ in.	8		4
32 x 3½	23½ in.	⅜ in.	1⅜ in.	1½ in.	8		4
34 x 3½	25½ in.	⅜ in.	1⅜ in.	1½ in.	12		4
36 x 3½	27½ in.	⅜ in.	1⅜ in.	1½ in.	12		4
40 x 3½	31½ in.	⅜ in.	1⅜ in.	1½ in.	12		4
30 x 4	20½ in.	⅜ in.	1⅜ in.	1½ in.	8		4
32 x 4	22½ in.	⅜ in.	1⅜ in.	1½ in.	8		4
34 x 4	24½ in.	⅜ in.	1⅜ in.	1½ in.	8		4
36 x 4	26½ in.	⅜ in.	1⅜ in.	1½ in.	12		4
40 x 4	30½ in.	⅜ in.	1⅜ in.	1½ in.	12		4
32 x 5	20½ in.	⅜ in.	2¼ in.	1⅜ in.	8		4
34 x 5	22½ in.	⅜ in.	2¼ in.	1⅜ in.	8	4	
36 x 5	24½ in.	⅜ in.	2¼ in.	1⅜ in.	12	6	
40 x 5	28½ in.	⅜ in.	2¼ in.	1⅜ in.	12	6	
40 x 6	26½ in.	⅜ in.	2¼ in.	2 in.	16	6 to 8	

**BOLTS THROUGH TIRE.**—The bolts that go through the tire are all equidistant from each other. They have square shoulders to prevent turning. The inside flanges are punched with square holes. The nuts should always be on the outside of the wheel.

## DISEASES OF A GASOLENE AUTOMOBILE

**BOLTS THROUGH FELLOE.**—Any number of these may be used as long as the number be not less than specified. Unless otherwise ordered, flanges will be drilled and punched according to specifications. In some cases bolts will go through spokes, but this does not weaken the wheel any, on account of using small sized bolts and on account of the bolts lying directly underneath the iron tire. All bolts have square shoulders to prevent turning.

### THE AKRON CLINCHER TIRE.



Fig. 6—Proper Position of Tire on Rim.



AND HOW TO CURE THEM.  
**The Goodyear Clincher Tire.**

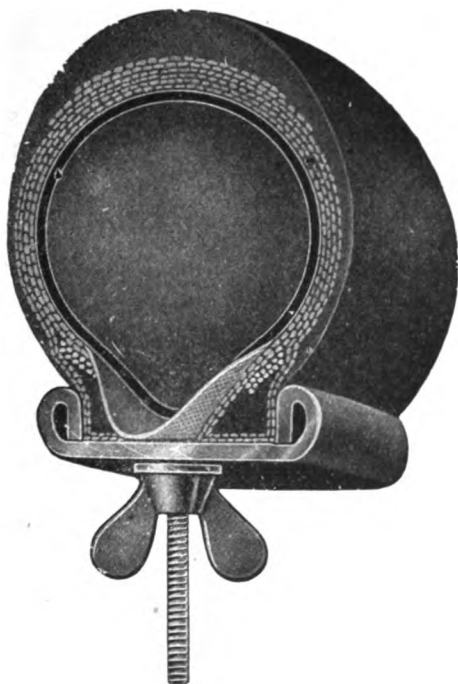

Fig. 6—Proper Position of Tire on Rim.

**TO REPAIR THE GOODYEAR AND AKRON CLINCHER TIRES.**—Immediately a puncture is discovered the tube should be replaced. Do not put off making the repair until a favorable opportunity should present itself, as nothing will ruin a tire quicker than riding it deflated.

**REMOVING THE COVER.**—1st. Be sure that the tire is completely deflated.

2nd. Remove the clamping nut on the valve so that the valve will slip through the hole in the rim.

3rd. Loosen the butterfly nuts on the tire bolts and push the tire bolts up into the tire as far as they will go without taking the nuts completely off (see Fig. 7). This sets free the edges of the cover.

4th. To get the edge of the cover out of rim on one side with two tire levers.

## DISEASES OF A GASOLENE AUTOMOBILE

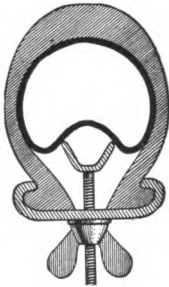

Fig. 7.

(a). To introduce the first lever, wet the end "A" (see Fig. 8) to make it slip easily on the rubber. Sieze the crown of the tire midway between two tire bolts, avoiding the proximity of the valve, and push the tire from you until the edge of cover is free from the side of the rim. Then by a **gentle** oscillating movement, from right to left, work one of the detaching levers until the flat end "A" (see Fig. 8) is under the edge of cover and the shoulder "C" of the lever rests against the edge of rim (see Fig. 9).

(b). To introduce the second lever, it should be inserted between the edge of the tire and the rim, at a distance from the first lever equal to one-third of the diameter of the tire. The diameter of the tire is plainly moulded upon the cover. Insert the second lever at the point indicated in the same manner as the first, taking care that it is

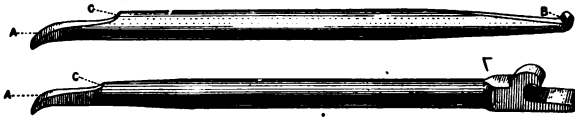

Fig. 8.

not opposed to the valve or a mushroom (tire bolt), although there is no objection to the levers being one on each side of a mushroom, and care should be taken that the mushroom should be thrust well up into the tire as in Fig. 7.

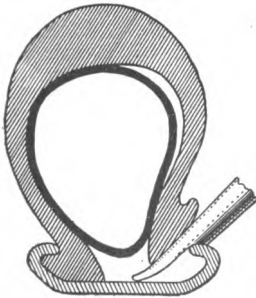

Fig. 9.

(c). To detach a portion of the edge of the cover, sieze the levers, one in each hand, as in Fig. 11, and press down toward the hub of the wheel simultaneously, as in Fig. 12. The portion of the cover edge between the levers will slip out of the rim by the time the hands touch the spokes. If this does not occur, and the tire edge fails to leave the rim, then the levers are too far apart and must be brought closer together. If, on the contrary, the edge of the tire having been brought out on the rim, slips back again,

## AND HOW TO CURE THEM.

then the levers are too close together, and must be separated a little. But if care is taken to introduce the levers under the edge of the cover at a distance of one-third of the diameter of the tire apart, such trouble will not occur.

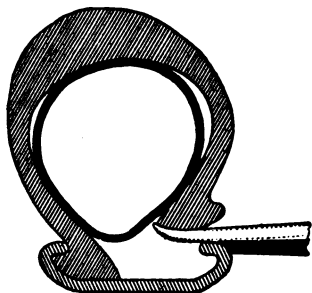

Fig. 10.

be readily withdrawn.

(e). After the edge of the cover is free all around, the next thing is to remove the tube, that is, if a spare one is to be put in. To do this, put the hand within the cover, the back of the hand being toward the rim, and work the fingers around

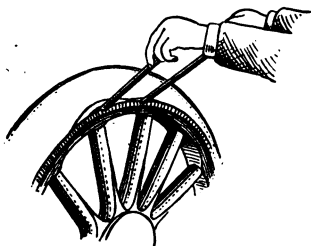

Fig. 11.

the tube until it is grasped in the hand. Gently pull out the tube, being careful that it does not catch under the mushrooms. In the event of the tube having become attached to the cover through overheating by fast running, very careful treatment is required if the tube is to be saved. The parts where the tube is stuck should be brought to the lowest point of the wheel's diameter, and a small quantity of petrol or other rubber solvent should be poured into the cover, around the part stuck. In a short time, and by the use of small quantities of solvent as required, the tube may, bit by bit, be detached from the cover. It is, of course, in a sticky state, and care should be taken that while

## DISEASES OF A GASOLENE AUTOMOBILE

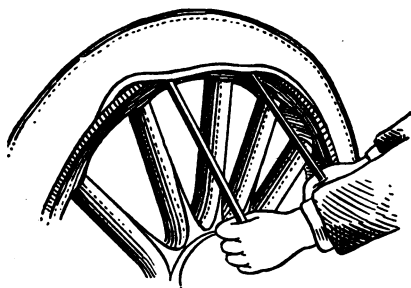

Fig. 12.

freeing one part of the section stuck, another part previously detached does not again adhere. Having freed and removed the tube from the cover it should be allowed to become quite dry at the places where it has been stuck before anything more is done to it. When dry, treat to a liberal dose of French chalk, rubbing it well in; at the same time

treat the inside of the cover in a similar manner. Under no circumstances, should a tire be replaced on a rim without having both the tube and the inside of the cover well rubbed with French chalk, and a small quantity of it should be left free in the tire. If too much be left in the tire it will probably form into small, hard pellets, in which case the chalk does more harm than good. Spare tubes with valves complete, should be carried in a bag, which we supply, containing a quantity of French chalk. They should never be allowed to knock about loose with the tools or spares.



Fig. 13.

(f). In replacing a tube, put the valve through the valve hole first (see Fig. 14) and very slightly inflate. This helps to prevent the tube being twisted while being put in. To put the tube in, start at the valve, and, holding out the edge of the cover with one

hand, put in the tube with the other, working on either side of the valve equally until the last bit is put in opposite the valve. Inflate the tube a little more, and starting at the valve, pass the hand all around the tube, in order to make quite certain the tube is not twisted.

(g). The next thing is to replace the cover. This is done almost the reverse way of detaching it. Starting at the valve, put the edge of the cover into the rim, keeping the valve lifted against the top of the cover. When about six

## AND HOW TO CURE THEM.



Fig. 14.

lever. The tube will offer some resistance to the cover being put in, if it contains too much air; in this case, let out as much air as is necessary. Special attention should be given to the tube when a mushroom is being passed; this should be pushed up into the cover as far as possible, and the cover edge worked well into the edge of the rim before pulling down the mushroom. The last third of the cover's circumference will have to be put in with the tire levers. This is not a very difficult matter, as the cover only requires to be held by the lever at one point (see Fig. 15A), while the other lever is used to lift the cover in. It is always best to put the last bit of cover in opposite to a mushroom, as this keeps the tube up in the cover and prevents it being nipped when the last piece of the edge snaps in. Particular care should be taken to see that the edge of the cover is well bedded into the inturned edge of the rim.

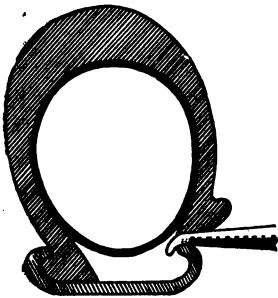

Fig. 15.

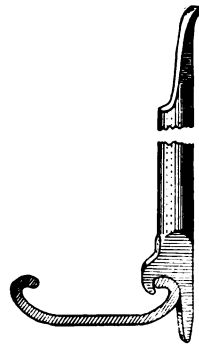

Fig. 15A.

## DISEASES OF A GASOLENE AUTOMOBILE

Push down the mushrooms as far through the rim as possible, by bearing on the cover above them, but before finally tightening up a little more air should be put into the tube. The cover should be grasped in both hands, close together, and the tire settled down by being pushed first away from and then pulled towards the operator. This "kneading" allows the tire to work in place, and should the tube have become nipped between the edges of the cover it gives it an opportunity of freeing itself, and so preventing further damage. Screw home the mushrooms by means of the butterfly nuts, and tighten up the valve before finally blowing up the tire.

**REPAIRING THE TUBE.**—Never repair a tube and put it back in the cover immediately afterward. The cement requires hours to thoroughly dry out.

(a) Locate the leak in the air tube in the usual way by slightly inflating it and immersing in water, or, if water is not handy, hold the tube close to the face when the escaping air will be felt.

(b) Test the valve by holding it in a cup of water while the air tube is still inflated. Spare parts of the valve will be found in the repair kit to remedy any defective parts. Never disturb the parts fastening the valve to the air tube.

(c) To repair a leak in the tube, thoroughly clean the surface, the size of the patch to be applied, around the leak with gasoline. Then roughen the surface of the air-tube with the piece of sandpaper in the repair kit. Apply a coating of cement to the tube and to the inside of the patch. Allow cement to become dry and then apply another coating to each. When the second coating has become tacky apply the patch with pressure. Lay the tube on a flat surface and put a weight on top of the patch and leave undisturbed for at least four hours.

## AND HOW TO CURE THEM.

**REPAIRING THE COVER.**—In case of a cut in the outer cover clear through the fabric to the tube, a patch of spread fabric should be applied on the inside.

(a) Clean the inside of the cover thoroughly with gasolene and apply coating of cement, allowing it to get tacky.

(b) Apply another coating of cement and when it has become tacky apply the patch of spread fabric—rubber side next to cover.

(c) If the cut in the outer cover should be over one inch in length, two thicknesses of spread fabric should be used.

(d) If the cut in the outer cover is over two inches long the thick rawhide patch should be used.

**THE REPAIR KIT.**—In the Repair Kit will be found the following:

1. Tool for removing nuts (when flange tires are used).  
See page 26.

1. Tools for removing covers (when clincher tires are used).  
See page 27.

2. Box containing two tubes of cement, half-dozen patches and spare valve parts.

3. Patches.

4. Wooden Box.

5. Roll of Spread Fabric.

6. Sandpaper.

7. Tube of French Chalk.

8. Rawhide Patch.

**THE RAWHIDE PATCH** consists of a piece of genuine rawhide covered with fabric which is frictioned, and is to be used in repairing clincher or detachable covers for the double tube tires. It is to be used in the same manner as the spread fabric, the rawhide patch being used for a cut in a cover larger than two inches, while the spread fabric is to be used for smaller cuts. The rawhide is much stronger and will not stretch.

## DISEASES OF A GASOLENE AUTOMOBILE

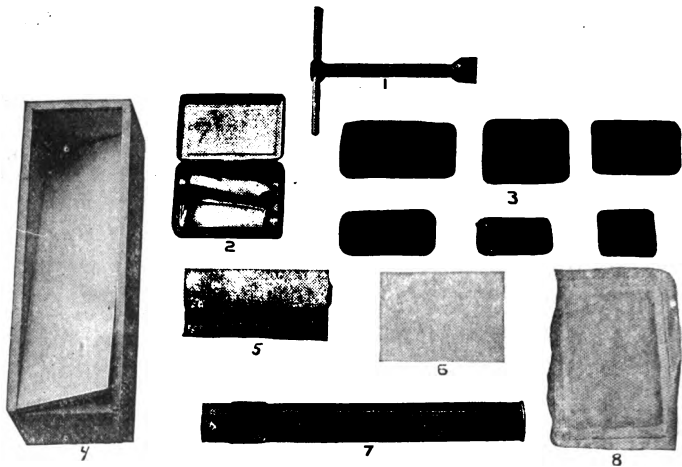

Fig. 17—Repair Kit for Goodyear Detachable Tires.

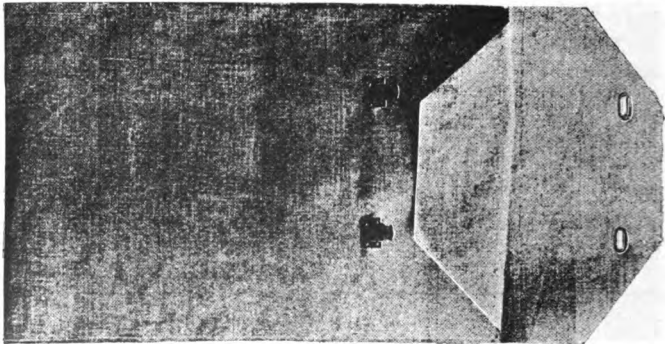

Fig. 18—Inner Tube Bag.

**INNER TUBE BAG.**—(See Fig. 18.) These bags are water-proof and large enough to contain three tubes. Plenty of French chalk should be in and around the tubes. The air-tube should never be allowed to knock about with the tools or spare parts.

**OUR INNER TUBES.**—These are made extra thick according to the latest European formulæ and designs and our patrons will find them to give the greatest service. We make tubes in French sizes also.



## AND HOW TO CURE THEM.

# Our Valves.

We use a Special Valve made to our order by A. Schrader's Sons. The feature of our valve is that by unscrewing the hexagon nut with the fingers the inside of the valve can be removed very easily and quickly, thus deflating the tire very rapidly. The inside (spring, etc.) and caps can be procured of the Dyke Automobile Supply Co.

### PARTS OF VALVE.

- A. Valve Cap.  
Should be ordered as "Figure 99-1."
- B. Valve Insides.  
Should be ordered as "Figure 99-4."
- C. Valve Barrel and Swivel Nut.
- D. Valve Barrel Washer.
- E. Valve Stem.
- F. Rim Clamping Nut.
- G. Rim Clamping Nut Washer.
- H. Hexagon Base Nut.
- I. Base Plate.
- J. Base Washer.

## DISEASES OF A GASOLENE AUTOMOBILE

### Other Tires.

We regret that we did not receive illustrations in time for the

**Goodrich,**

**Diamond,**

**Hartford,**

**Dunlop,**

**Fiske**

tires. The tire directions given practically cover the ground, however, with the exception of the Fiske which is an original type and the reader can write this firm for their booklet which will describe same.

**INSTRUCTIONS.**—By the Diamond Rubber Company for repairing their detachable tires on the road, written expressly for this book.

#### METHOD OF REPAIRING INJURIES TO THE CASING.

Temporary repairs made as hereinafter described will enable one to reach a repair station 150 miles distant.

In most cases, one side only of the casing need be laid open. In case, then, of a cut or puncture, proceed thus:

Lay open the casing; choose a frictioned fabric patch large enough to extend one and one-half ( $1\frac{1}{2}$ ) inches two (2) inches beyond the cut in each direction. Stick this patch in its place with cement. (Do not put on too much, and let it dry.)

## AND HOW TO CURE THEM.

Now inflate to about two (2) pounds pressure and adjust over the cut a rawhide manchon (which are furnished separately and at small cost). This will prevent water or dirt from getting into the casing. Lace the manchon over the rim with flexible cord, just as a shoe would be laced; then inflate to full pressure.

### METHOD OF REPAIRING INNER TUBE.

In this case the inner tube is supposed to be punctured, but the casing practically uninjured, as in case of puncture by a pin or nail.

First of all, satisfy yourself that the pin or nail is not sticking in the casing, for if it is, your repaired tube will be punctured again before you have gone 1000 feet.

Having done this, the inner tube may be removed (wholly or in part as may be necessary) and either repaired or replaced.

When on the road it is much simpler to put in a new tube; and it is best to have always at hand three spare tubes—one for the forward and two for the rear tires. An inner tube properly repaired is as good as new, but it is much more easier to make the repair at home. *Do not* carry these tubes in the tool box where they are liable to be bruised or otherwise injured.

To proceed, the injured portion of the tube being laid bare, proceed *leisurely* as follows:

Select a patch of the right size; that is, large enough to extend  $\frac{3}{4}$  of an inch or an inch beyond the puncture in each direction. Wipe off every trace of moisture or bloom and roughen with emery cloth the surfaces to be joined. Apply two coats cement to the tube surface and to the patch, removing with the fingers all superfluous cement; the less of it there is, the more quickly will the repair be accomplished.

Allow the cement to dry until it adheres strongly to the fingers (five minutes at least will be needed), then, and not until then, apply the patch; compress strongly and look carefully to see that the edges of the patch do not loosen.

## DISEASES OF A GASOLENE AUTOMOBILE

Before putting back the tire assure yourself that the part of the tube opposite the puncture (that is, next the rim) has not been punctured also. It often is when the puncture is caused by a long pin or nail.

**NOTE.**—Never try to join two surfaces while they are still damp, for rubber cement joints are of no value unless everything is dry. Never apply friction fabric to an inner tube, but always a patch of pure caoutchouc. Friction fabric is not airtight.

The **Goodrich** and other double tube tires are practically repaired in the same manner.

**TO PREVENT PUNCTURES.**—I notice frequent reference to the difficulties resulting from tire punctures on automobiles.

I experienced the same difficulty, but have had no trouble since I made use of an outer covering formed by cutting a good heavy bicycle tire along the inside centre so that it could be spread and applied on the outside of the automobile tire. The latter was first covered with a cement coating, which was allowed to dry, then with another cement coating, which remained until it was sticky, and the inside of the bicycle tire was coated in the same manner and then applied and bound into place with tape until the cement had set. I found that with such coverings the perforation of the outer covering by a nail or tacks or the cutting with glass or stones had no effect in materially perforating the inner tire. Occasionally the outer tire works loose and has to be re-cemented.

Seconds can be used for the the front wheels just as well as not, but owing to the force applied to the rear wheels and the slip it is better to get an outside covering of first-class quality and the heavier the better.

All dirt should be washed off the tires, and, having dried them carefully, cuts and bad places should be cleaned out with benzine and then plugged and cemented with pieces of pure rubber and solution, so that they may be allowed as much time as possible to harden before being again used. On no account should a deflated tire be allowed to support the weight of the car. If it is not convenient to repair the tire at once, the weight of the car should be taken off it by a jack or other support.

## AND HOW TO CURE THEM.

Tires should always be kept as hard as possible without exceeding the pressure that the tire is able to stand. If the tires are allowed to remain soft, the internal friction set up is very great and will eventually tend to perish the rubber and canvas, injuring the tube and causing much trouble later on.

Tires should always be well inflated. It is always policy to carry along spare outer covering and inner tube.

**TIRES:** Never start out without well inflated tires. A half inflated tire causes the car to skid, and the outer cover or shoe to creep around the rim, pulling the inner tube with it, resulting in the valve being pulled out and causes the tire to heat quickly, thus destroying the life of the tire.

Never start out without an extra inner tube.

Whenever a strange noise, entirely foreign to the motor or gears, develops, get out and investigate. This may save a lot of time and trouble in the long run and always recollect the fact, that a locomotive after a hard run is taken to the engine house to be cleaned and thoroughly looked over, and an Automobile requires the same attention only on a smaller scale.

When approaching a particularly rough crossing, always throw out the clutch so that no undue strain is put on the gears or motor, for in this way all the strain is taken up by the springs and tires.

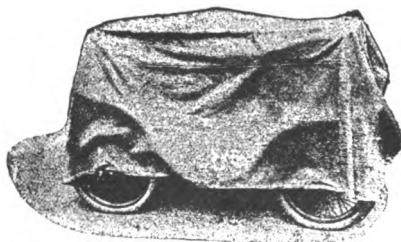

**Every Machine Should Have a Cover.**

## DISEASES OF A GASOLENE AUTOMOBILE

### Lamps.

There are several types of lamps, but only two forms used. It is either oil or gas. The oil lamps burn regular kerosene or signal oil and the gas lamps secure the gas from carbide. The oil lamps are generally used for side lights and the gas lamps for headlights. The gas supplied to the gas lamps is generated by water dropping on the carbide which instantly form gas, which passes off through the tip made of lava placed in front of the reflector. The generators are sometimes placed in the bottom of the lamp and are also separated from the lamp proper and placed on the dash-board or some other convenient place, a rubber tube conveys the gas from the generator to the lamp.

Light cheap rubber tubing soon rots from this gas and it is advisable to use a good grade heavy rubber tubing.

**Reflectors** are the most important part of the lamp. The most popular form of lamp at present is the Mirror Lens Pro-

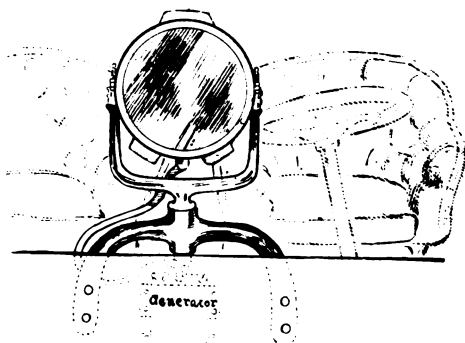

jector, which has a mirror reflector placed behind the tip and throws a power of ray a great distance ahead. These lamps are sometimes placed on shifting brackets, as per illustration, and can be thrown in any direction. Quite a handy device on dark nights in turning curves, etc.

AND HOW TO CURE THEM.

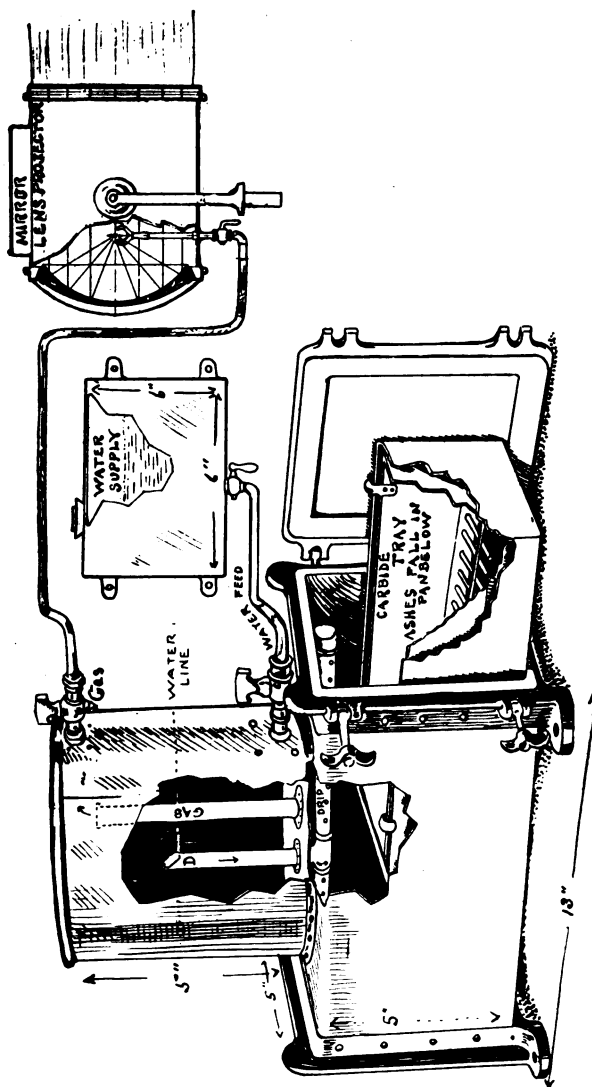

Plan Dyke's Gas System Lighting.

## DISEASES OF A GASOLENE AUTOMOBILE

**Tips** are generally made of lava. Two small holes are in each end, only one of these being discernible to the eye. The hole, however, which becomes clogged is the small hole inside the large one. Fig. 16 shows a special Tip Cleaner which fits into the small hole.

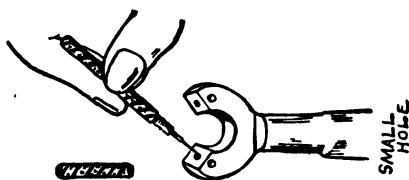

Fig. 16.

**Dyke's Acetylene Gas Generator**—Special type is shown in illustration on preceding page. The carbide is placed in the tray in large lumps, the tray is placed in the pan and shoved inside of the generator and door securely fastened. The water is fed from the small tank T, which is about six inches square, the water fill up into chamber C and overflows at tube D, which feeds the water to carbide. The gas then passes out gas inlet F. The ashes of carbide falls through tray into pan. The pressure is automatic, as the pressure of the gas keeps the water from feeding only as required.

These generators will supply gas for a week or more with one filling, and require no attention whatever, only to turn off and on the gas as needed. They will supply just as large a flame as any gas jet will permit. Made of copper and thoroughly reliable in every respect. Will feed several large lamps.



## AND HOW TO CURE THEM.

**TOOLS FOR ROAD REPAIRS.**—Even with the most careful attention which may be bestowed upon an automomile, defects are bound occasionally to develop while on the read, and it is then that the mechanical ingenuity of the operator is taxed to its utmost. Despite the fact that the space available for tools is usually limited, with a judicious selection of tools, nearly all emergencies or road contingencies can be successfully met. In

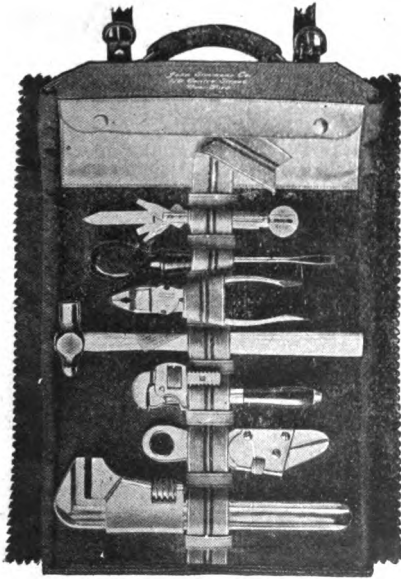

addition to the special tools usually supplied with a car, the following articles will be found of great use: A small pipe wrench, a pair of gas pipe pliers, a large and small screw driver, a pair of flat-nosed pliers, a small hammer, a pair of wire cutters, a lage jack knife, a flat, a half-round and a three-cornered file, a coil of soft iron wire, a roll of sticky tape, a cold chisel, a small ball pene hammer, a monkey wrench and some extra nuts and bolts, a few links of extra chain, including a match link, also extra chain for the

pump, including mated link, a piece of asbestos for making gaskets, fire repair tools, good jack, can of cylinder oil, can of grease, extra plugs.

A very handy tool set is shown in above illustration. It is the Dyke Auto Tool Set and was the first auto tool set placed upon the market. The tools are all carefully selected and enclosed in a leather case, which rolls up, making a very compact luggage.

## DISEASES OF A GASOLENE AUTOMOBILE

**TRANSMISSIONS.**—There are three main divisions of geared transmission: the sun and planet, the individual clutch, and the sliding gear.

The first of these were used by us on our earlier models because of the wonderful simplicity in operation which we obtained from its use. For this advantage, we paid in friction when any but the high gear was used. Difficulty

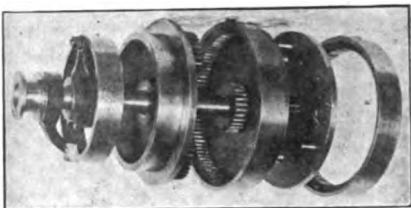

Sectional View—Sun and Planet Type of Transmission.

to secure proper lubrication at all times and the desire to secure something better led us to discard it in favor of a system slightly more complicated but infinitely superior.

The individual clutch system consists of several trains of spur gears, which are always in mesh upon two parallel shafts. The engagement of any clutch produces a certain ratio between the engine and rear wheels. This arrangement loses considerable power all of the time on account of the idle gears which are in mesh.

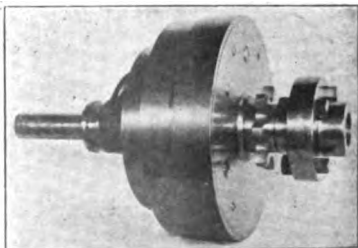

View showing Sun and Planet Type Transmission assembled. The speeds are obtained by tightening bands around the outer rims.

The sliding gear transmission consists of the same several trains of spur gears for producing the different ratios between the engine and the rear wheels. None of them is in mesh, however, until the operator selects the pair he wants. The fact that only two gears are in mesh at any one time insures the least possible loss by friction at all times.

The standing argument against this latter system has always been the danger of stripping the gear teeth by making a change

## AND HOW TO CURE THEM.

while power was being transmitted through them. In all of the French and many American adoptions this has been possible, and, consequently, a very serious disadvantage. By the use of a patented interlocking device we have been able to absolutely prevent this trouble, by making it impossible to move a single gear until the engine had been first disconnected.

**THE INDIVIDUAL CLUTCH.**— Sometimes called High-Speed Clutch.—The idea of the Friction Cone, as shown in figure 4, is to allow the motor to be disengaged from the gears when changing them, also to allow the car to be started and stopped without

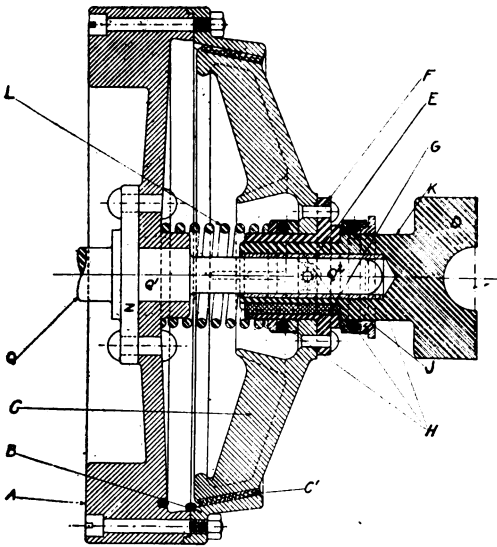

Individual Clutch.

any shocks. The flywheel *A* is a driving fit to *Q1*, and is riveted to flange *Z*. The conical clutch flange *B* being bolted on to the fly wheel. The universal coupling *D* connects with the transmission gear and has a bushing *E* and runs free on the Motor Shaft *Q2*. The collar *F* is keyed to universal coupling *D* by key *G* and the cone *C* is riveted to *F*, thus making *C*, *D* and *F* practically one. *C1*, is a band of mineral leather riveted on the rim of *C*, thus completing the clutch. The clutch is always held firmly against *B* by a strong spiral spring *L*. *H* are the ball bearings to take up the thrust when disengaging the clutch. In receptacle *K* fits a fork which throws the clutch in and out by a series of levers which are operated by the foot pedals. *J* being a washer which runs free on *D*.

stopped without any shocks. The flywheel *A* is a driving fit to *Q1*, and is riveted to flange *Z*. The conical clutch flange *B* being bolted on to the fly wheel. The universal coupling *D* connects with the transmission gear and has a bushing *E* and runs free on the Motor Shaft *Q2*. The collar *F* is keyed to universal coupling *D* by key *G* and the cone *C*

## DISEASES OF A GASOLENE AUTOMOBILE

**THE SLIDING GEAR TRANSMISSION.**—The clutches which carry the power from the engine to the gear box have already been touched upon, and the next section of construction to be considered is, therefore, the change speed mechanism,

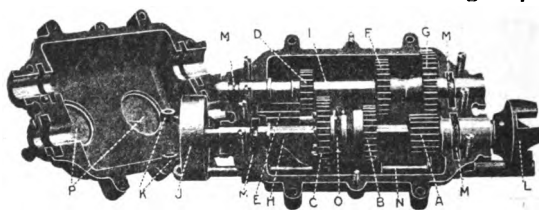

FIG. 5

Sliding Gear Transmission—The Peerless Type.

In all cases but one, a sliding gear was employed, and in the one exception no gear change at all was fitted. This is distinctly in favor of the sliding gear for racing purposes, and would appear to indicate a case of the survival of the fittest in many ways.

The number of speeds embodied in the various gear-boxes differ somewhat. The Mercedes employ four forward and reverse; the Napiers, three forward and reverse; Panhards, three forward and reverse; the Mors, three forward and reverse; the Peerless, three forward and reverse; the small Winton—Own's machine—two forward and reverse; and Winton's big machine, one forward and no reverse. The Mercedes gear comprises two parallel shafts, one driving the countershaft at right angles, and the other carrying a pair of sleeves with the sliding gears.

The motion of these sleeves is obtained from a pair of gear cut racks carrying the forks located in the upper part of the box, and a quadrant connected with the change speed lever gears, and operates these racks. The gear lever is mounted on a sliding sleeve, so that it can be moved along in either direction to engage the required rack. A third rack is used for reversing purposes, and apparatus is provided for locking the gear wheels in whichever position they may be.

The bevel wheel which drives the countershaft has a remarkably small angle, so that end thrust is eliminated as far as possible. The countershaft itself is only about  $1\frac{1}{4}$  in. diame-

## AND HOW TO CURE THEM.

ter, and its relative strength must be enormous. All the bearings in the gear-box and those belonging to the countershaft are of balls, and no adjustment is provided for taking up wear. The sprockets, which in the race had 28 teeth, are bolted to flanges at the ends of the shaft, and are gripped in addition by a steel boss and nut. The rear wheels are also run on ball bearings of exceptional size, and the chain wheels are attached by a series of short steel pillars to alternate spokes. A noticeable feature is that the lever comes to a dead stop in every speed—a definite advantage over the Napier, Panhard, Mors, Peerless and Winton, since in changing speed their levers move forward and depend on the finding of a notch, so that there is always danger of a mistake.

The Mors and Panhard cars, the only others using *s de* chains for their transmission, employed practically speaking, their usual gear, and no special description is necessary.

The Napiers all employed direct driving on the top speed, as did also the Peerless car and the small Winton. The Napier gear engages a dog clutch on the **face** of one **wheel**; the Winton does the same, and the Peerless slides one of the ordinary gear into an internal gear fixed to the tail shaft.

There was little difference in the bevel gear driving at the rear axle. In almost all cases roller bearings with ball thrust collars were employed, and the differential gear was, as usual with this type of driving, mounted in the center of the large wheel. In one case, at least, two bearings were used to support the driving pinion, but, as a rule, only one was used. The universal jointing of the shaft from the gear box to the back axle had evidently been the subject of much study, as some exceedingly substantial and well-designed joints were embodied, some having provision for continual lubrication, a distinct advance over the usual arrangements employed.

The methods of control on the Mors and Mercedes are alike, so far as the regulation of the engine speed is concerned, since both adjust the sparking lead and the throttle opening from quadrants concentric with the steering wheel. The Panhard machines regulate their engine from twisting handles forming one spoke of the steering wheel. The Napiers from separate handles, Winton's from a foot button, and the Peerless from separate handles.

## DISEASES OF A GASOLENE AUTOMOBILE

The braking on all the cars is very powerful, consisting except in the case of the Mercedes, of a foot brake, and expanding brakes in the rear wheels worked from a hand lever. The Mercedes has two foot brakes and the usual hand brake, but instead of the brake handle moving forward to apply the brakes, it moves back so that the driver has a direct pull on it. This in itself is a most excellent point of construction, since the driver is enabled to utilize his full strength on both set of brakes together.

**THE BEVEL GEAR DRIVE.**—Figure 8 shows the mechanism of the Bevel driving gear and differential. *A* and *B* being the

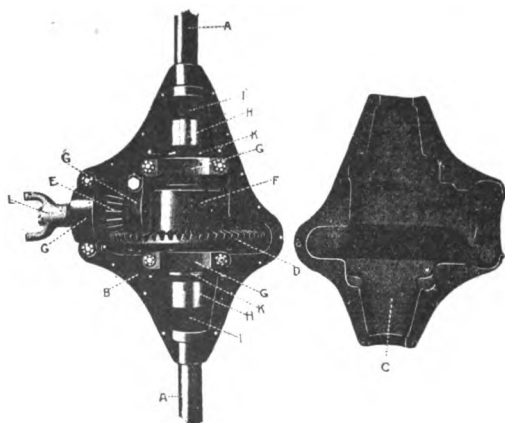

FIG. 8

The Peerless type.

are firmly bolted in place. Adjustment is arranged for by adjustor *K*. *H* is the universal coupling connected to the differential, *I* being the driving axle to the wheels, *L* is a yoke keyed and bolted on to the driving pinion, said yoke being connected to the flexible driving shaft. The whole is in a dust proof case and is filled with grease sufficient for six months' running. The gears can be examined at any time by simply removing top of case *C*.

**ADVANTAGE OF MULTIPLE CYLINDERS.**—The practice of the modern motor designer has developed a tendency towards multiplicity of cylinders. Many of the well-known makes

## AND HOW TO CURE THEM.

which were formerly built with a single cylinder are now double, or even built with three or four cylinders. The question of the proper number of cylinders for an internal combustion engine may be briefly summed up as follows: The single cylinder has the merit of simplicity, and requires least looking after, but tends towards excessive vibration. Multiple cylinders develop more power for a given weight of metal, and lessen vibration and therefore strain, and have many other advantages over the single type. The question to be decided is: What number of cylinders is best in theory and practice? We believe that when the perfected two-cycle motor has become un fait accompli, two cylinders, giving two impulses per revolution of the engine, will undoubtedly be found to answer best from every point of view. But, as we are yet a long way from this ideal, we may pass to the consideration of the types available at the present moment. To give the best results, a two-cylinder Otto cycle motor should, if the cranks are opposed, have its cylinders also in opposition in order to ensure a regular torque impulse. If the cranks and cylinders are not opposed it is impossible to obtain correct mechanical balance of connecting rods and pistons, and vibration is thus encouraged. If the cylinders are of the twin type with the cranks opposed, explosions must necessarily follow each other at the ratio of a half revolution, and one and a half revolutions apart. This produces irregular torque impulses which set up vibration. The best type appears to be the three-cylinder engine, with the cylinders placed parallel, and the cranks set at an angle of 120 degrees apart. This gives regular impulses two-thirds of a revolution apart, and consequently even strain on the parts, and conduces towards absence of vibration.

The four-cylinder engine has, of course, all the advantages of mechanical balance claimed for the three-cylinder type; but, on the other hand, by reason of the greater extent of cylinder wall for given cubic capacity, it is not as economical in fuel and water consumption. The only advantage of the four as compared with the three cylinder motor, is a greater division of the torque impulses, but as the difference is only one-twelfth in the four-cycle engine, the added complication does not seem to pay for the comparatively small advantage gained. On the other hand, the three-cylinder motor has an advantage over the

## DISEASES OF A GASOLENE AUTOMOBILE

four, in that all three of the cylinders can be combined in one casting, giving lightness, rigidity and strength as compared with the usual type of four-cylinder engine, which is usually made up of two twin castings. One of the things to be most carefully avoided in motor designing is any semblance of unnecessary complexity, and the three-cylinder engine, with its advantages of steady torque, light weight, and simplicity of design and manufacture, seems to be as near the desideratum as it is possible to attain at the present time.

**SHARP POINTERS AND HORSELESS SENSE.**—Because people stare at you is no sign you are handsome, there may be soot on your nose.

Because you can start with a jerk, whiz around corners and stop from high speed in two feet, doesn't signify that the crowd think you a wonder. The level headed majority probably notice that your mental mixture is not perfect and are attracted by the smoke.

Don't cut dados unless the public are paying you well, for every frill is costing you good money.

Let it be your aim to so thoroughly master your machine that it will appear as a part of yourself; instinctively reading and obeying your will; performing every movement with deliberation and such entire lack of haste as will inspire confidence in the public and the respect of your friends.

If you have the occasion to go after trouble, lose no time in getting there, but learn to let well enough alone.

Keep your eye on the oil supply and always have a full tank of water and plenty of gasolene.



## AND HOW TO CURE THEM.

### Pointers in Purchasing a Machine.

There are a great many things which go to make up an Automobile upon which the intending purchaser should post himself thoroughly before buying.

Even among the few acknowledged leaders in the business to-day will be found different constructions, with every one, for arriving at the same end. There is absolutely no use denying that each one has some good in it. It is just as sure to contain some disadvantage. You must decide whether the good is there for you or for convenience in manufacture; whether it will cause the purchaser nothing but trouble, or if the disadvantage is suffered by the builder alone and you are the gainer thereby.

**NOT ABSOLUTELY NECESSARY, BUT PERTINENT.**—No piece of machinery was ever made which would run continuously without some care and attention.

When you buy an automobile, there is formed an unwritten agreement between you and the machine. You expect to receive certain benefits from its possession. It, likewise, exacts a penalty from you in direct proportion to your own demands.

You cannot make it a one-sided proposition, in which everything is your own way, and anyone trying to so convince you is a lineal descendant of Ananias.

An automobile is almost human, but it is unable to build up out worn tissue or to recuperate in the slightest from the effects of hard usage.

Right here is where the machine has its claim on you. The manufacturers plan and build to the best of their ability and provide means for prolonging the life of the carriage, but the amount of pleasure you receive will depend upon the care you take of it.

**THINGS TO CONSIDER IN PURCHASING.**—**Safety** of Motive Power. **Simplicity** of Drivers' duties. **Reliability** of Motive Power. **Durability** of Mechanicisms. **Freedom** from Noise and Odor. **Low** Motive Power Cost. **Controllability**. **Weight** efficiency. **Radius** of Action.

## DISEASES OF A GASOLENE AUTOMOBILE

The arrangement of all parts so as to be easily accessible for repairs and adjustment.

The proper weight and diameter for fly wheels, and the correct balancing of the reciprocating parts.

The best tires to stand their work and prevent any tendency to slip on greasy roads.

The most useful power of engine for general all around road use; which means plenty of hill climbing power, and not too great a speed on the level. Catering to racing men and those who like engines of excessive weight and power might safely be left to makers who imagine there is profit in that class of business.

The desirability, or otherwise, of complicating the machine with variable speed gears and water cooling.

The best system of ignition, having in view the elimination of sparking troubles.

Automatic lubrication of the engine.

The best system of silencing exhaust.

The best system of transmission. This at present seems to be divided between rigid chains with slipping catches and slightly elastic belts which drive smoothly and slip naturally.

The most efficient and economical mechanical carburetter which would require the minimum of attention. The surface type, it might be assumed, would soon become obsolete.

The best methods of actuating and governing the inlet and exhaust valves.

The best practice in driving or controlling the engine, either by throttling the exhaust or inlet, or both.

Position and number of levers, and the advisability, or otherwise, of coupling or combining into single lever control.

The speaker said it would also repay makers to study well the practice adopted on stationary gas engines. In considering the points specified, the maker should never lose sight of the fact that in nine cases out of ten the machines would go into the hands of novices, and, therefore, simplicity and reliability must be the keynote of his work.

Apart from the points mentioned for the study of manufacturers, it was advanced that there are many matters which

## AND HOW TO CURE THEM.

must be considered by the agent. He must buy and sell carefully, ride a machine himself, closely study the engine, study well the papers which deal with automobiles, and keep thoroughly in touch with the movement. An agent should give careful practical study to the following points:

Thoroughly master the action of the engine and all its parts, and understand why a motor goes, and under what conditions it will not go.

Thoroughly master the ignition system, giving special attention to the action of the coil. Buy a voltmeter to test accumulators, and also learn how to tell their condition from the appearance of the plates. If the agent has electric light on his premises, he should learn how to charge accumulators from it.

## Diagrams of all Standard

**ELECTRICAL CONNECTIONS**, using the regular type of contact shown on page 15. The cam being grounded.

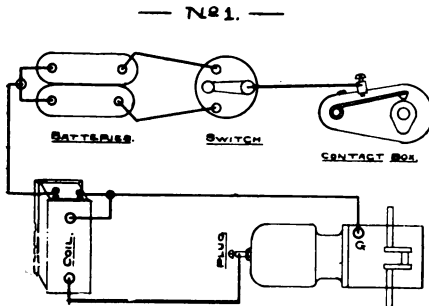
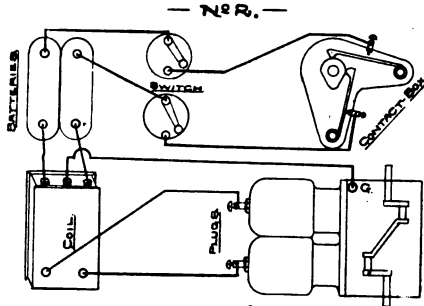

FIG. 1—Single Cylinder Engine with Two Sets  
Batteries, Cam grounded.

# DISEASES OF A GASOLENE AUTOMOBILE



NO. 2—**Double** Cylinder Engine with Double coil and One Set of Batteries for each Cylinder—cam grounded.

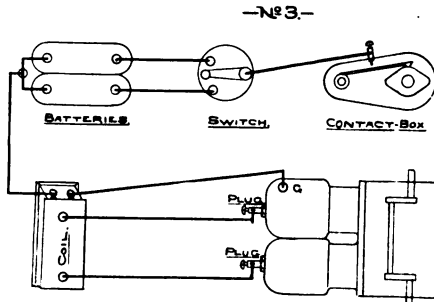

FIG. 3 - **Double** Cylinder Engine with Pistons traveling together—one coil for both Cylinders and **Two** Sets of Batteries, cam grounded.

AND HOW TO CURE THEM.

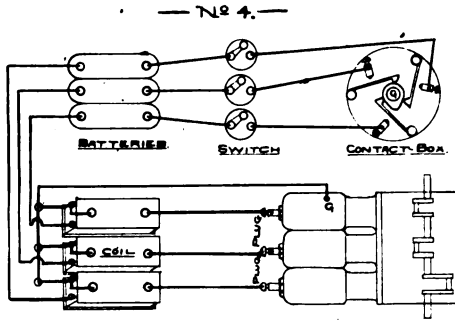

FIG. 4—Three Cylinder Engine with Three Sets of Batteries and Three Coils—cam grounded.

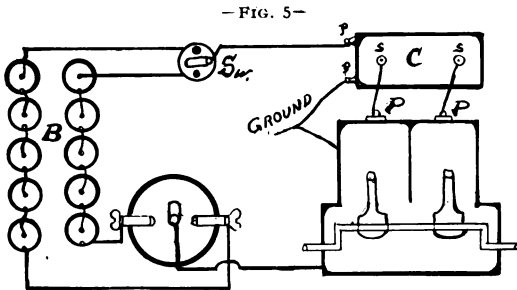

FIG. 5—Double Cylinder Engine, Pistons travel together—  
one coil—two sets of batteries, one set  
worked at the time.

## DISEASES OF A GASOLENE AUTOMOBILE

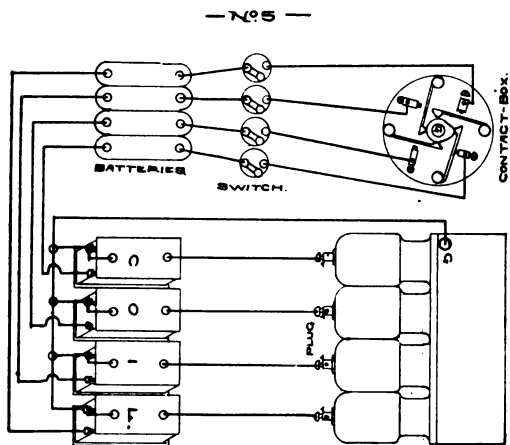

FIG. 6—Four Cylinder Engine with four coils and four sets of Batteries—cam grounded.

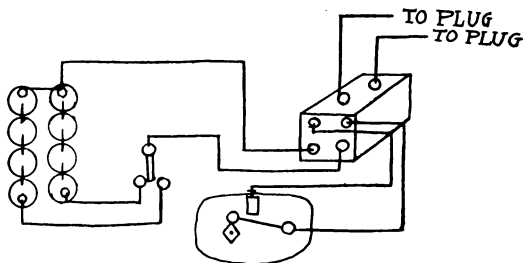

FIG. 7—Double Cylinder opposed type engine with **Two** Sets of Batteries—one set to work at a time—one coil. Notice commutator or cam.

AND HOW TO CURE THEM

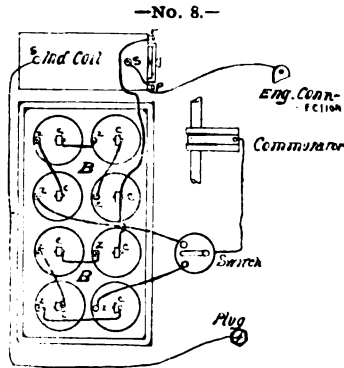

FIG. 8—Oldsmobile Plan of Wiring—  
 can grounded—Two Sets of batteries,  
 one set operated at the time.

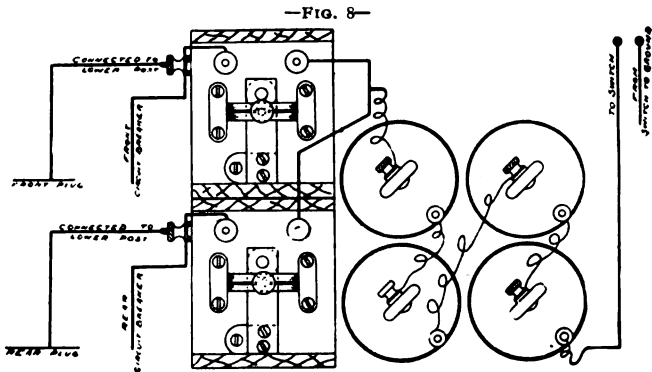
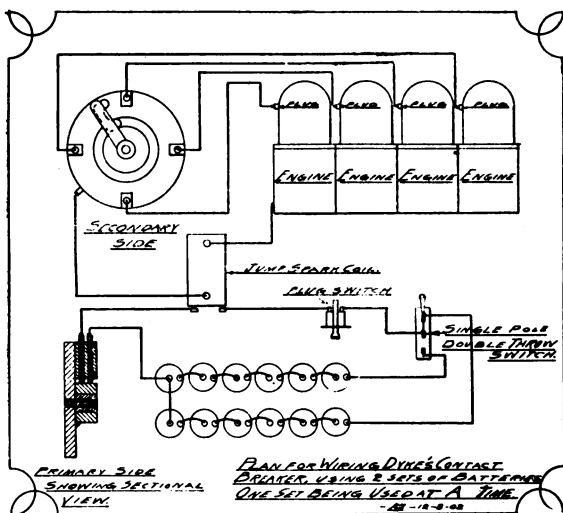

Diagram for wiring two coils  
 and one set of batteries

No. 9—Steven's Duryea Plan wiring—opposed engine—two coils, one set  
 of batteries.

## DISEASES OF A GASOLENE AUTOMOBILE



No. 10 Dyke's Special Contact Box for 4-cylinder engine **using only one coil.** Illustration shows **Primary** and **Secondary.** The primary and Secondary circuits are broken at the same time. One round disc with primary on one side and secondary on the other.



AND HOW TO CURE THEM.

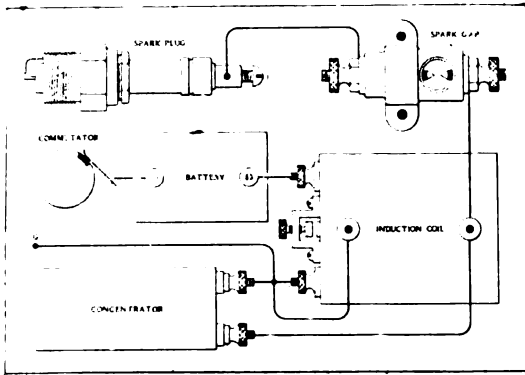

No. 11.

No. 11 shows single coil for single engine with cam on commutator grounded. One set Batteries, Spark Gap and Concentrator.

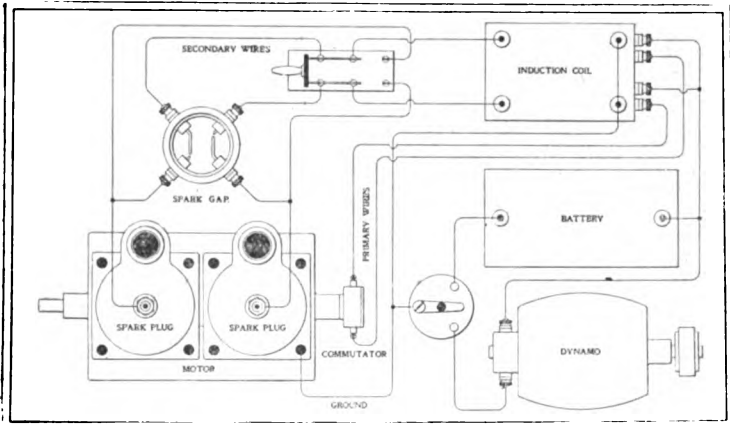

No. 12.

No. 12 Double Cylinder Engine with Double Coil, Double Spark Gap, Dynamo and Battery.

## DISEASES OF A GASOLENE AUTOMOBILE

### Dyke's Brush System Contact Device Connections.

The cam is not grounded. See illustration page 16.

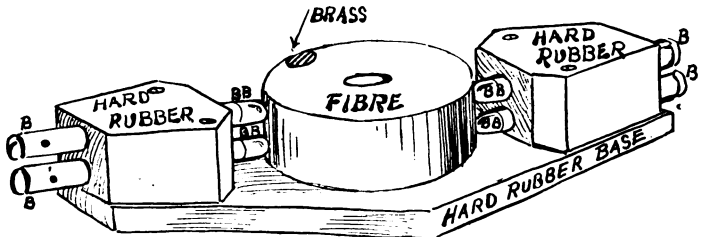

For Opposed Type Engine.

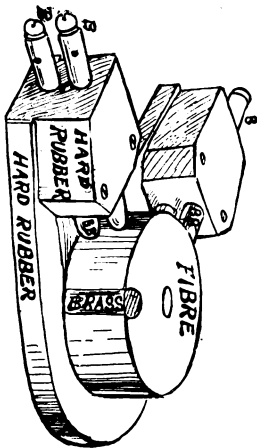

For Twin Cylinder Type Engine.

The illustration on page 16 shows a contact box for a twin type engine with crank shaft set. The illustration above shows opposed type contact box. The Dyke Brush System is conceded the most economical and reliable on account of both the primary and secondary connections being separated.

AND HOW TO CURE THEM.

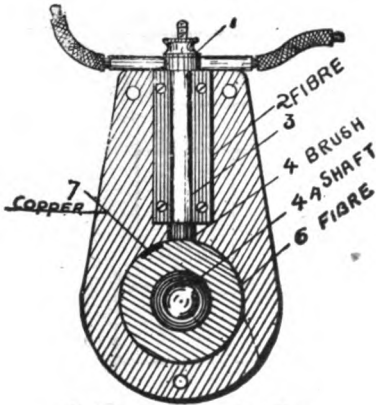

Dyke's Single Contact Box.

**FOR SINGLE CYLINDER TYPE ENGINE.** — In some cases where opposed engine is run with one coil this contact device can be used with two strips of brass placed opposite on commutator.

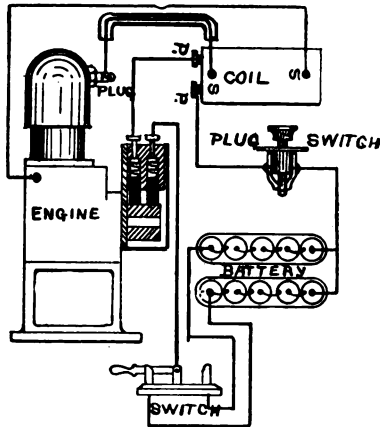

Plan of Connection Showing the Dyke Brush System Contact Box Connected to Single Engine.

—FIG. 13.—

**FIG. 13—Single Cylinder Engine—**one coil—two sets of batteries—one set worked at a time—with Dykes Brush System contact.

## DISEASES OF A GASOLENE AUTOMOBILE

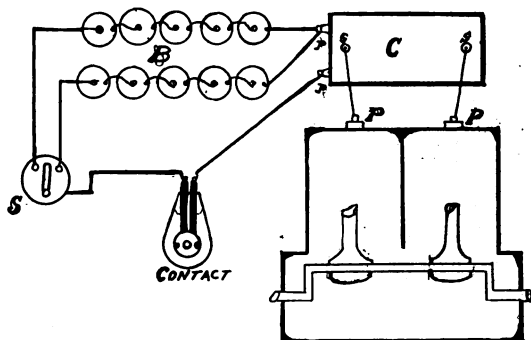

—FIG. 14—

FIG. 14—Double Cylinder Engine—one coil—both pistons travel together — two sets of batteries, one set at the time used. Notice commutator with contact strips placed opposite. Dyke Brush system contact used

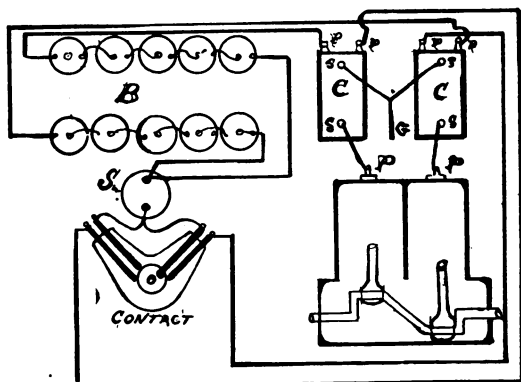

—FIG. 15—

FIG. 15—Two cylinders—two coils—one set Batteries for each cylinder Dyke's Brush System contact.

AND HOW TO CURE THEM.

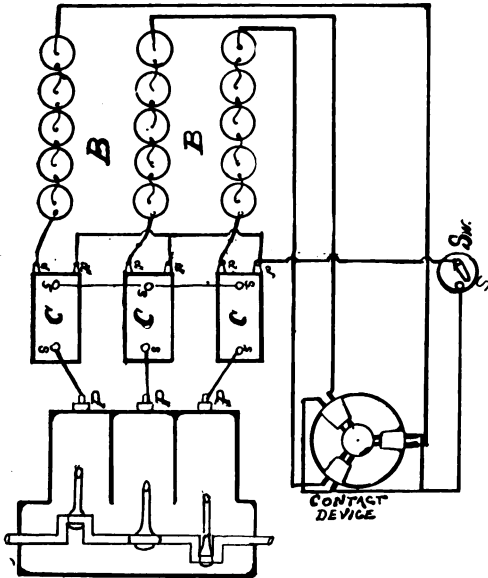

—FIG. 16—

FIG. 16—Three Cylinders—three sets of Batteries, one set for each cylinder—three coils—Dyke Brush System contact used.

## DISEASES OF A GASOLENE AUTOMOBILE

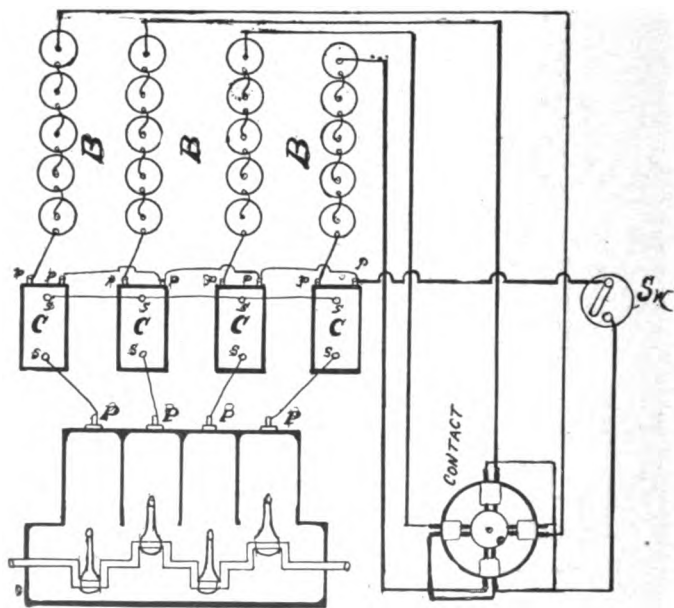

—FIG. 17—

FIG. 17—Four Cylinders—four Coils, four Batteries, one set for each Cylinder—Dyke Brush Contact System used.

AND HOW TO CURE THEM.

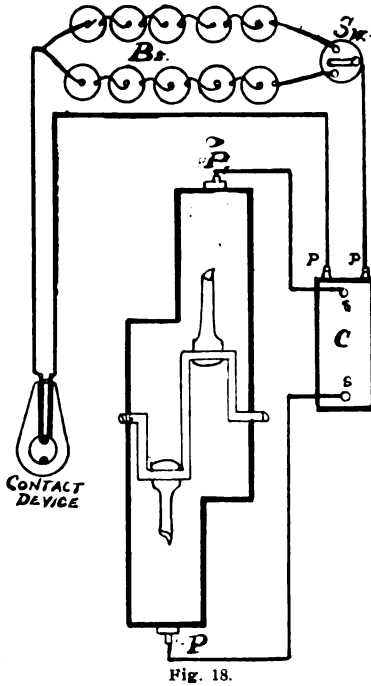

**FIG. 18—OPPOSED TYPE ENGINE.**—Single Coil, two sets Batteries, one set worked at the time. Note contact strips placed opposite on commutator.

Fig. 18.

DISEASES OF A GASOLENE AUTOMOBILE



**G & J Tires are tough and strong;  
easily mended if punctured; Highest  
grade made.**

**G & J TIRE Co.**  
Indianapolis, Ind.  
U. S. A.





Ask to See the...

**FLAT TREAD  
CORRUGATED**

## Akron Clincher Tire

**Fits Standard Clincher Rim  
Prevents Side-Slipping**

We also make the Akron Clincher Tire with regular elliptical tread. Also Goodyear Detachable Tires, Goodyear Single Tube and Goodyear Endless Solid. Ask for details.

## The Goodyear Tire & Rubber Co.

AKRON, OHIO, U. S. A.

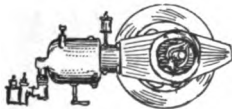

Horizontal Type.

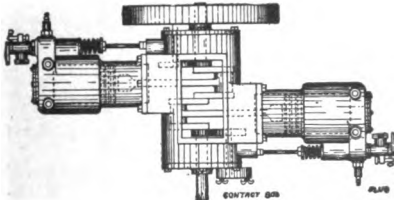

Opposed Type.

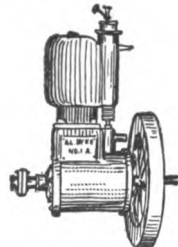

Vertical Type.

We furnish Castings for several types of Gasolene Engines. See our catalogue.

**A. L. DYKE AUTO SUPPLY CO., ST. LOUIS, U. S. A.**

DISEASES OF A GASOLENE AUTOMOBILE

# MOTOR AGE

The Automobile Authority of America

## GETS THE NEWS

Get **MOTOR AGE**, the most up-to-date automobile weekly

**10c per copy at your newsdealer**

**Subscription, \$2.00 per year**

# MOTOR AGE

1303 Michigan Ave.

CHICAGO

---

**GAS POWER**



**GAS POWER**

**"GAS POWER"**

An ably edited monthly magazine devoted exclusively to the gas and gasoline engine industry.

*One of the leading manufacturers says:*

"We compliment you on Gas Power. It is very handsomely gotten up and treats on topics that will be of material advantage both to the dealers in and users of gas and gasoline engines."

It will give YOU valuable suggestions.  
Subscription price, 50c per year.  
Sample copy on request.

**GAS POWER PUBLISHING CO.,**  
217 Court St. St. Joseph, Mich.

**GAS POWER**

AND HOW TO CURE THEM.

...THE....

# Automobile Magazine.

Oldest and best publication for those interested in Automobiles. Sample copy for your asking it of the publishers.

## The Automobile Press.

1 MAIDEN LANE.

NEW YORK CITY.

---

==== READ =====

## The Automobile

A Live Illustrated Weekly about care and operation, new vehicles, races, endurance runs, shows, general news and information.

Get posted before you buy and after you buy keep posted.

It will save you many times its cost. **PUBLISHED WEEKLY. \$2.00 a Year. SEND FOR FREE SAMPLE COPY.**

## THE AUTOMOBILE

FULLER BUILDING, NEW YORK.

Send 50 cents for three months' trial.

DISEASES OF A GASOLENE AUTOMOBILE

# THE HORSELESS AGE

---

E. P. INGERSOLL, EDITOR AND PROPRIETOR.

---

PUBLICATION OFFICE:

TIMES BUILDING, - - 147 NASSAU STREET.  
NEW YORK.

---

SUBSCRIPTIONS FOR THE UNITED STATES AND CANADA,  
\$2.00 a year, in advance. For all foreign countries included in the  
Postal Union, \$4.00.

Single copies, 10 cents (in the United Kingdom, sixpence).

---

....The....

## Cycle and Automobile Trade Journal.

AMERICA'S LEADING AUTO JOURNAL.

A Sample Copy Will Convince You. Profusely Illustrated.

**LEST YOU FORGET, SEND FOR SAMPLE COPY.  
YOU WILL THEN SEND FOR THEM ALL.**

Trade Advertising and Publishing Co.,  
1213 Filbert St., PHILADELPHIA, PA.

206

AND HOW TO CURE THEM.

50 YEARS' EXPERIENCE

# PATENTS

TRADE MARKS  
DESIGNS  
COPYRIGHTS & C.

Anyone sending a sketch and description may quickly ascertain our opinion free whether an invention is probably patentable. Communications strictly confidential. HANDBOOK on Patents sent free. Oldest agency for securing patents. Patents taken through Munn & Co. receive special notice, without charge, in the

**Scientific American.**

A handsomely illustrated weekly. Largest circulation of any scientific journal. Terms, \$3 a year; four months, \$1. Sold by all newsdealers.  
**MUNN & Co.** 361 Broadway, New York  
Branch Office, 625 F St., Washington, D. C.

---

## The How and Why of Electricity.

---

By CHARLER TRIPLER CHILD.

Late Technical Editor of the *Electrical Review*.

---

**Just Issued. Price \$1.00. Postage Prepaid.**

---

New York *Sun*: "We know nothing that gives so much real help in so short a space."

New York *Tribune*: "Admirably adapted to instruct the non-technical reader."

—PUBLISHED BY—

# *Electrical Review,*

13 Park Row, NEW YORK.

Sample Copy ELECTRICAL REVIEW 10c.

## DISEASES OF A GASOLENE AUTOMOBILE

### "The Most Interesting of Mechanical Journals"

Is what a prominent manufacturer said not long ago of

# Modern Machinery.

Anyone engaged in business which has to do with machinery will find it to be truly a journal of mechanical progress. It is written for the busy man who would keep abreast of the times and deals with those subjects which are of current interest. Here is a partial list of contents in the May, 1903, issue:

Modern Machine Tools In Foreign Army Service.

German Praise for American Inventor

The Steam Turbine as a Reserve Power.

English Milling and Drilling Machines.

An English Compound Oil and Gas Engine.

How to Prevent Boiler Explosions.

Motors for Interborough Rapid Transit Co. In New York City Subway.

Report of Alfred Mosely's English Commission on American Tour.

David Starr Jordan's View on Opportunities for Young Men.

Effect of Machinery.

Utilizing Lignite.

Old Time Machine Shop.

New Method of Casting Steel.

Demand for Steel Castings in Ireland.

New Tool Steel.

New Method of Brazing Castings.

Test of Stamping machines in England.

Profusely Illustrated.

Advertising Rates on Application.

Growth of Locomotive Industry.

Wire Nail Industry.

World's Inventors.

Improved High Speed Tool Steel.

Use of Electricity on German Vessels.

Steel Factory in Spain.

Expiration of Storage Battery Patents.

Failure of Large Locomotives.

Uses for Rawhide.

Old Time Machinist.

How Cold Rolled Shafting is Made

Use of Tools, Jigs and Fixtures for Modern Machinery.

Accurate Tools and Methods.

Setting Tool for Taper Taps.

Bending Copper Pipe.

Making Packing Rings.

Questions and Answers.

Technical Training for Shipbuilders.

Recent Improvements in Machine Tools.

Notes, News and Personals.

Book Reviews.

Each Issue Full of Interest.

Price \$1.00 a Year.

Publication Office, Security Bldg., CHICAGO.

## THE DURYEA SYSTEM

Consists of a very compact triple cylinder motor with planetary transmission gear on the same shaft, both small enough to be placed under the operator's seat, which permits a wide variety of styles of vehicle to be produced with the same mechanism. From the transmission gear a single Duryea self-oiling chain transmits the power direct to the rear axle. The triple motor gives from ten to twelve horse power and is designed to bring all parts, such as valves, sparking mechanism, cam shaft and crank bearing caps in an easily reached position on top of the motor when the cushions and crank case are removed. A glance therefore at the system shows instantly where the trouble is and what to do to fix it. The primary ignition has but one wire, and the insulated plugs are easily removed for cleaning. On no account is it necessary to get under the vehicle to make repairs. Very truly,

**DURYEA POWER CO., Reading, Pa.**

AND HOW TO CURE THEM.

# Originators



**First Auto Supply Business in America.**

**First Auto Supply Catalogue in America.**

**The present largest Auto Supply Catalogue.**

**Manufacturer of the first American-made Running Gear without reaches.**

**Manufacturer of the first Float Feed Carburetter, Radiator, Wheel Steering Device, etc.**

**Originators of "Dyke's Outfits" for assembling your own car.**

**The first concern in America to build a machine with Tonneau and Top with glass front.**

**We are constantly getting out New Devices and Printed Matter. It will pay you to be on our Mailing List.**

**A. L. Dyke Auto Supply Co.**  
**2108 Olive Street, ST. LOUIS, MO.**

DISEASES OF A GASOLENE AUTOMOBILE

**The First Auto Tool Set Placed on the Market.**

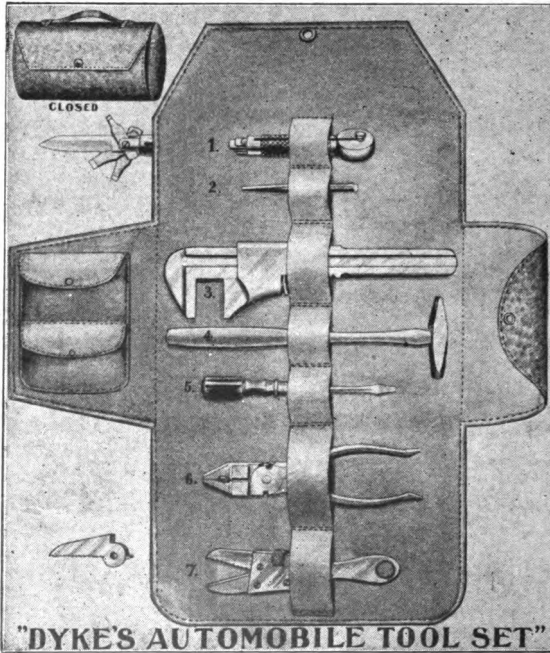

**A CAREFULLY SELECTED LOT OF TOOLS**

**Fit For The Finest Machines.**

**✿ WILL SAVE YOU TIME AND ANNOYANCE. ✿**

**PRICE :**

Nickel Plated, in Leather Roll.....\$10.00

**A. L. DYKE AUTO SUPPLY CO.  
ST. LOUIS, U. S. A.**



AND HOW TO CURE THEM.

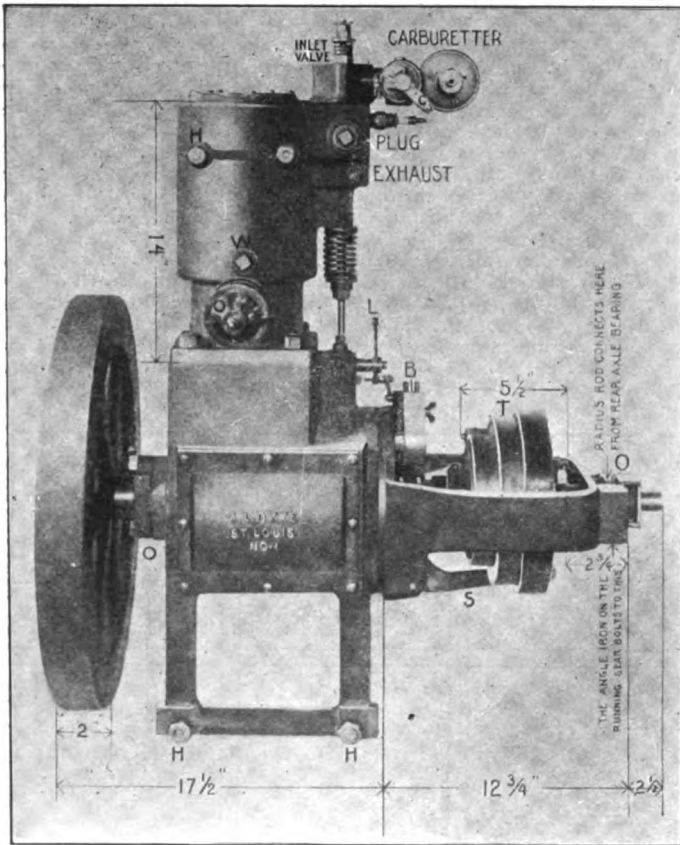

## Dyke's No. 1 Engine

With Transmission built Direct on Engine Shaft. Cylinder 5 $\frac{1}{4}$ x6.

We sell the engines **Complete** or the **Castings**.

# A. L. DYKE AUTO SUPPLY CO.

ST. LOUIS, U. S. A.

211

## DISEASES OF A GASOLENE AUTOMOBILE

### Warning Signs Designed by American Motor League.

The American Motor League has devised a series of warning signs to be put up at points along the roadside, wherever conditions are such as call for reduced speed or unusual caution on the part of persons using motor cars. The designs adopted by the League are in some respects similar to the caution signs put up by the English, French and Italian automobile associations, though less complicated, it having been the aim of the League to reduce each sign to its lowest terms of simplicity, so that each will tell its story at a glance and by the use of the fewest marks possible. Referring to the numbered signs shown in the cut, **No. 1** indicates approach to a steep descent; **No. 2**, approach to a railroad crossing; **No. 3**, approach to a branch road (to right); **No. 4**, approach to branch road (to left); **No. 5**, approach to cross-roads; **No. 6**, approach to a ditch or abrupt depression in the road; **No. 7**, approach to a hummock or "thank you, ma'am;" **No. 8**, approach to a city, village or other collection of inhabited dwellings; **No. 9**, is a general caution signal indicating the proximity of any danger or obstruction not scheduled above.

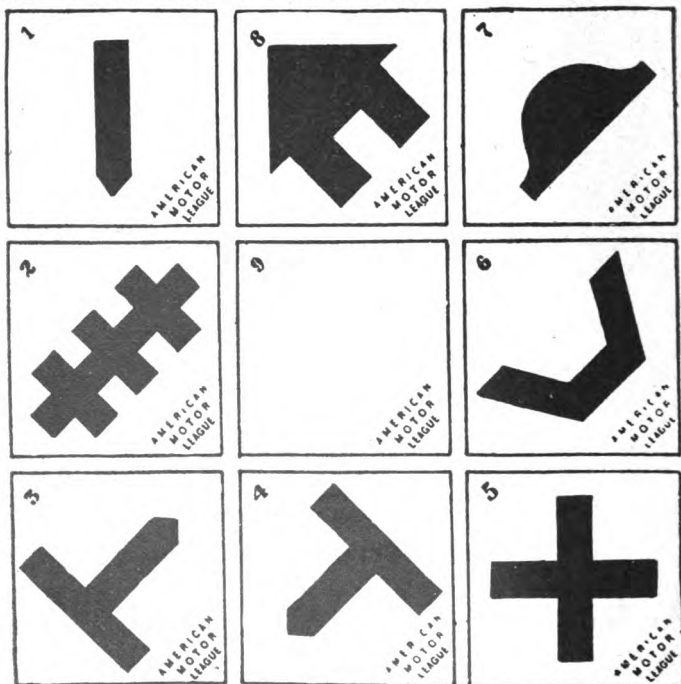

Road Signs for Automobilists—Designed by American Motor League.

≡≡≡ 3 in 1 ≡≡≡

**PRACTICAL** FOR USER  
FOR DEALER  
FOR MAKER

And best of all for the man who wants to buy an automobile right.

**AUTOMOBILE REVIEW,**

The Practical Automobile Journal.

It tells the truth about Automobiles. It pays Advertisers. Send for rates.

**AUTOMOBILE REVIEW,**

21 Quincy Street, - - CHICAGO.

**W**E desire to acknowledge our indebtedness to the **AUTOMOBILE REVIEW** of Chicago, that most practical of automobile journals, for a large amount of the technical matter pertaining to automobile troubles and how to diagnose and overcome them.

# DYKE'S AUTOMOBILE BULLETIN

A MEDIUM FOR ALL INTERESTED IN NEW  
MOTORITIES.



THIS BULLETIN is published monthly, 15,000  
copies will be distributed.

ITS OBJECT is to show the latest Auto Devices,  
offer suggestions and hints and to be of  
general interest to our customers.

*SUBSCRIPTION PRICE, - YOUR TRADE.*



PUBLISHED MONTHLY

**A. L. DYKE AUTOMOBILE SUPPLY CO., Inc.**

2108 OLIVE STREET, . . . ST. LOUIS, MO.

"ORIGINATORS."

AND HOW TO CURE THEM.

# **The Most Successful Method Of Firing the Charge in a Gas Engine.**

**THE ONLY MACHINE ON THE MARKET**

That successfully does away with the use of the starting and running battery. The Auto-Sparker has been on the market for

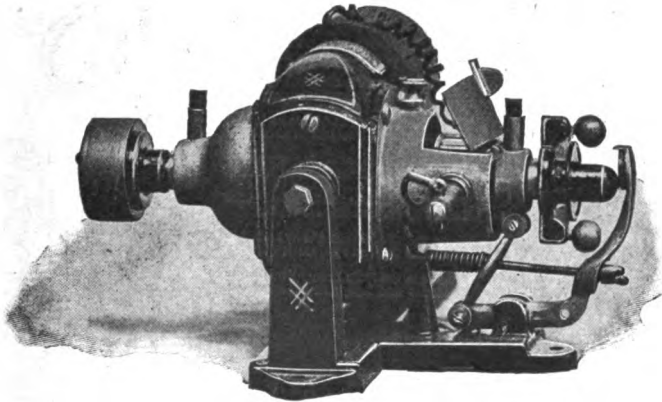

**The Improved Auto-Sparker.  
No Battery. No Belt. No Switch.**

three years and has given satisfaction where used. A point of superiority is its uniform speed regardless of the speed of the engine, which means that the spark does not vary in size and burn the contact points in your engine. It works equally well with the jump or contact spark, but for jump spark a coil with the proper resistance must be used. It will work in any position in boats or automobiles and is not easily effected by dampness. These machines have been under water in boat for (12) twelve hours without damage to them. We can furnish the best recommendations for the machine and guarantee it to be all claimed for it.

**MOTSINGER DEVICE MFG. CO.,**

**220 Main Street, Pendleton, Indiana, U. S. A.**

Ask for catalog.

# A SCORCHER'S AUTO - BIOGRAPHY



In the Automobile that Jones bought.

This is the Owner, who with pride  
Climbs up for his first inspiring ride.

This is the Avenue, nice and broad,  
Through which he hurtles, overawed.

This is the Horn that blares so loud,  
And paralyzes a luckless crowd.

These are the mounted Coppers grim,  
Who gallop to succor life and limb.

This is the Ambulance here and there  
Collecting specimens past repair.

These are the Things the vehicle hits  
And butts to pieces before it quits.

These are the Bills brought in—boo hoo!  
For arms and legs, and funerals, too.



AND:

This is the Street Car which to-day  
Carries along his humble way

That Chap who settled the Bills—boo hoo!  
For arms and legs, and funerals, too.

And for numerous Things the racer hit  
And butted to pieces before it quit,

The while the Ambulance here and there  
Collected specimens past repair.

Following close the Coppers grim  
Who galloped to succor life and limb.

In the wake of the Gong that clamored loud,  
Quite paralyzing the luckless crowd

Upon the Avenue, nice and broad,  
Along which hurtled, overawed,

His post for the first inspiring ride  
A man who took, with an Owner's pride,

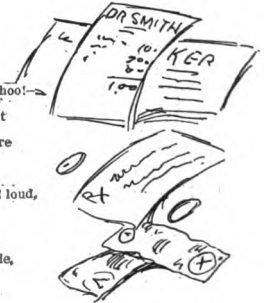

From the *Motor World*.

AND HOW TO CURE THEM.

You Take a Walking Chance Without It.

# Auto Tire-Sleeve

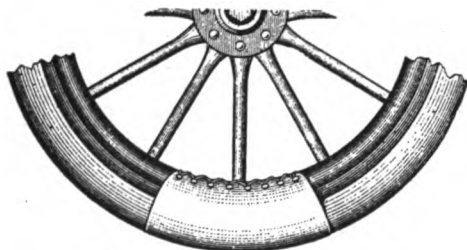

Puncture Proof. Made of Flexible Hard Rawhide.

**Affords Perfect Protection to a Damaged Tire.**

The **Auto Tire Sleeve** is made of flexible hard rawhide, and is puncture proof. Is moulded to shape of tire, and fits perfectly when adjusted. Can be slipped over tire and laced firmly into place in a few moments' time.

**Any Puncture**, no matter how bad, can be quickly repaired, and the Auto Tire-Sleeve will afford perfect protection to the damaged tire until such time as it is convenient to have vulcanizing or permanent repairs made. Automobiles have been run hundreds of miles with Auto Tire-Sleeves protecting badly damaged tires.

**Natural Rawhide.** The Auto Tire-Sleeve is made of transparent, hard rawhide, and nothing is used in process of manufacture that will prove injurious to rubber tires.

### MADE IN THE FOLLOWING SIZES:

3	in.	including patch and lacing.....	\$1 50
3½	in.	“ “ “ .....	} 1 75
4	in.	“ “ “ .....	
4½	in.	“ “ “ .....	} 2 00
5	in.	“ “ “ .....	

(Without patch and lacing 25c less.)

Sent by mail, postage paid, upon receipt of above price.

— FOR SALE BY —

**A. L. DYKE AUTO SUPPLY CO., St. Louis, Mo.**

## DISEASES OF A GASOLINE AUTOMOBILE

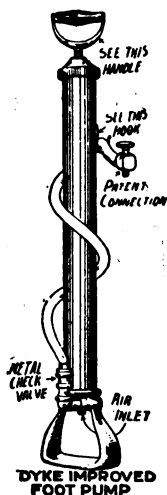

**No. 1**

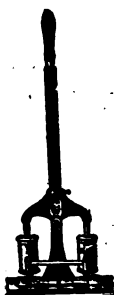

**No. 2**

There is nothing which will cause a man to lose his temper quicker than to attempt to pump up tires with a pump that won't pump.

The only reliable auto pump for carrying with you is the Dyke No. 1. Made of brass with **metal checks**, which can be re-ground. Practically indestructible. Notice other features.  
**Price, No. 1.....\$3.50**

**No. 2** is a pump for the stable. It saves time and exertion. You can stand up and use it. No stooping.  
**Price.....\$12.00**



**No. 1269.** Cap with short visor is the cap. In Silk or Leather.

**Best grade.....\$4.75**

We have them cheaper.

**Tourists** Leather Caps, with flaps to pull down over the ear.....**\$3.50**

Fur Gloves, Long Leather Coats, Winter Masks, etc., carried in stock.

**A. L. DYKE AUTO SUPPLY CO., St. Louis, Mo.**



AND HOW TO CURE THEM.

**OLDS HEADLIGHT.**

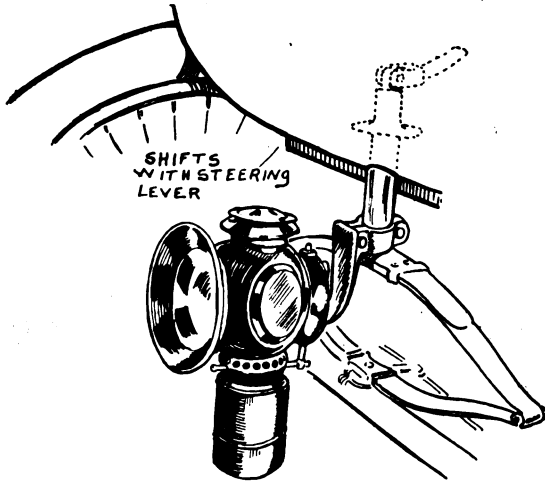

On Such Machines as Oldsmobiles this Headlight is desirable, or at least our sales would lead us to believe that such is the case. This lamp is a small Acetylene Gas Headlight for placing on the steering part just above the spring on the Olds. It throws ample light. Simple, light, placed at the right place and is just the thing.

PRICE. Lamp, \$6.00. PRICE, Bracket, \$2.50

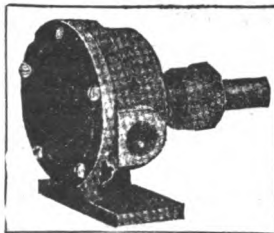

I have known cases where machines were a source of annoyance simply because the pump was no good and the water could not be kept in circulation and engine would become heated and knock. Take our word for it. This one is all right.

PRICE, Brass .....\$6.50

DISEASES OF A GASOLENE AUTOMOBILE

# High Grade Imported Auto Horns.

Undoubtedly the Finest Horns Made.

**THE REEDS** are the patented adjustable type.

**THE BULBS** are a glossy black instead of a dull rubber color.

**GUARANTEED** to be the finest horn made. If not as represented return and we will refund your money.

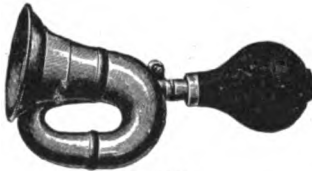

No. 1150.

D. 3 $\frac{1}{2}$  in. L. 10 $\frac{1}{2}$  in. Price, \$3.25



No. 828.

D. 3 $\frac{1}{2}$  in. L. 9 $\frac{1}{2}$  in. Price, 2.50

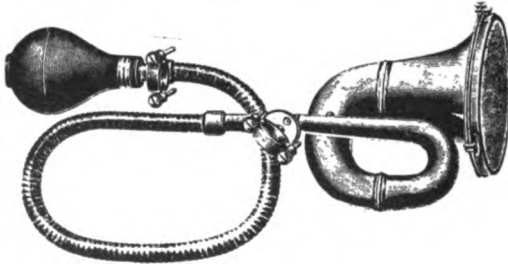

No. 208

No. 208. D. 5 $\frac{1}{4}$  in., Nickel and Brass, Price with Tubing and Screen, \$10.00

DYKE'S No. 67 is an extra large Horn, about as large as practical to use. D. 8 in. Price, with Tubing and Screen..... \$16.50

D.—Diameter of Bell. L.—Length of Horn, including Bulb.

Brass Horns Carried in Stock.

Nickel Horns Furnished on Order.

## A. L. Dyke Auto Supply Co.,

ST. LOUIS, U. S. A.

AND HOW TO CURE THEM.

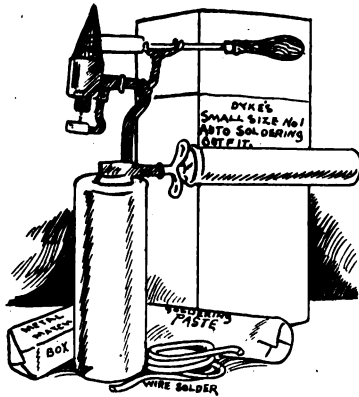

**DYKE NO. 1 AUTO SOLDERING OUTFIT.**

Is smaller and suitable to carry along in hamper or tool box. The box takes the entire outfit. Very handy in case of tank leaking, etc. Can be started instantly with 1 match. Outfit consists of:

Soldering Iron .....	\$0.50
½ lb. Wire Solder.....	25
1 Tube Soldering Paste .....	35
1 Pocket Torch .....	2.00
<b>Outfit Complete.....</b>	<b>2.95</b>

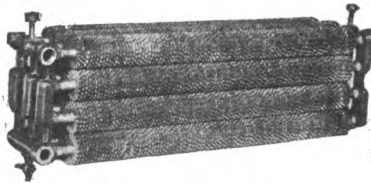

**DYKE'S RADIATORS**

are being fitted to some of the best cars in the country.

## DISEASES OF A GASOLINE AUTOMOBILE

### THE AUTOMOBILE NUT LOCK WASHER.

IT KEEPS YOUR NUTS FROM WORKING LOOSE.

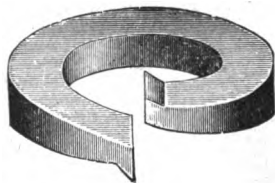

A Little Thing But How Useful.

**Are you aware** that more than 90 per cent of the accidents on automobiles come from nuts coming loose? Every nut on the automobile should be locked, owing to the intense vibration the machine is subjected to. The ease with which they can be put on and removed, commends itself to the manufacturer. A nut can not be jarred loose by vibration and can only be removed by using a wrench.

Try a sample order and be convinced. Once used always used. Send for prices stating quantity and size.

**To-day** you should have John, James, or whatever his name may be, go carefully over your machine and find out what nuts should have these washers. **Give us the diameter of the bolt and we will do the rest.**

It may save your machine for a wreck. Still more, it may save your neck.

**Price each, .05; \$10 per 1000**

AND HOW TO CURE THEM.

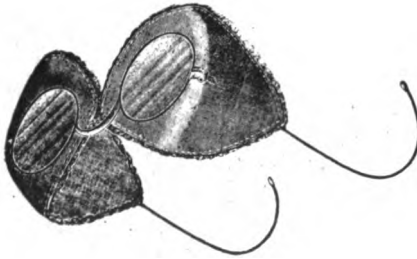

**DYKE'S No. 1 GOGGLES.**

Keeps out bugs and dust. Without the chenelle lining it would not do it.

PRICE.....\$2.50



**THE "STA-RITE" SPARK PLUG**

in all threads and at right prices.

Price, Single Lots..... \$1.50

DISEASES OF A GASOLENE AUTOMOBILE

# Dyke's Auto Baskets.

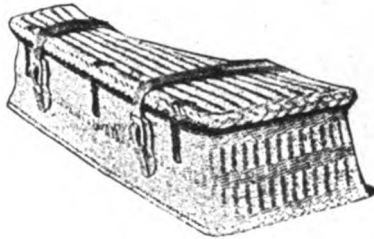

Best grade, polished, rattan, waterproof baskets to fit all type of machines.

---

Golf Baskets.

---

DON'T FAIL TO GIVE US YOUR BUSINESS IN  
THIS LINE.

---

**A. L. Dyke Auto Supply Co.,**  
2108 Olive St., ST. LOUIS, MO.

AND HOW TO CURE THEM.

**HOT!!**

MY DEAR SIR—I advertise because it is cheaper than writing letters.

By the way, you use **Cylinder oil** and other kind of oils—you buy cheap oil because you get more of it—you think it lasts just as long as any other oil and you are having trouble. In fact any old oil looks alike to you. You would get better results if you use **good oil**.

The next time I mention this matter I think I will write you a personal letter. Now what are you going to do?

A great number of troubles with gasolene engines is due to **Poor Grade of Oil**. Did you ever stop to think that the oil must be **absolutely fire proof**. Did you ever think about the oil being exposed to a **flame** inside of the cylinder? If your oil is not **fire proof** then it instantly turns to carbon and deposits on your plug and causes miss firing.

For several years I have tried to get a good oil. I have never found but one oil concern in the U. S. that makes a really fire test oil. Personally I have tried every oil on the market but there are none to compare with this oil. We buy it in large quantities and call it **Dyke's Gasolene Engine Cylinder Oil for the Cylinder**.

**DYKE'S LUBRICATING OIL FOR THE CRANK CASE.**

It costs more than other oils but lasts longer and saves trouble and annoyance.

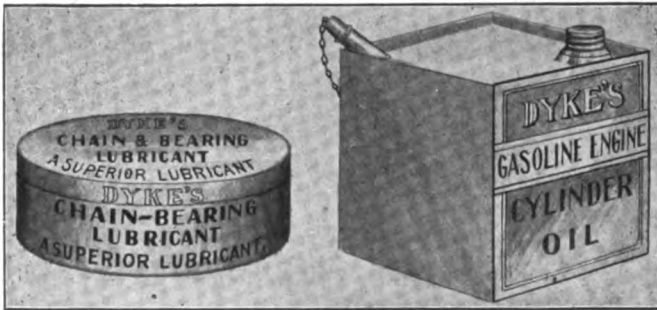

**DYKE'S GASOLINE ENGINE CYLINDER OIL FOR THE CYLINDER.**

Gallon cans, incl. can, net.....	\$1 25
Quart    "       "       "       "       "       "	50
5-gal.   "       "       "       "       "       "	5 75
Per gal. by the barrel.....	1 00

**DYKE'S GREASE FOR COMPRESSION CUPS.**

5-lb. cans.....	\$1 50
-----------------	--------

**DYKE'S LUBRICATING OIL FOR CRANK CASE.**

Gallon cans, incl. can, net.....	\$1 25
Quart    "       "       "       "       "       "	50
5-gal.   "       "       "       "       "       "	5 75
Per gal. by the barrel.....	1 00

**DYKE'S CHAIN LUBRICANT.**

2-lb. Cans.....	\$0 75
5-lb. Cans.....	1 40

Send in sample order. It will pay. Don't let the Oil Man tell you he has something just as good.—He has not.

**A. L. DYKE AUTO SUPPLY CO., St. Louis, Mo.**

DISEASES OF A GASOLENE AUTOMOBILE  
**MACHINE MADE UP FROM DYKE'S No. 1 OUTFIT.**

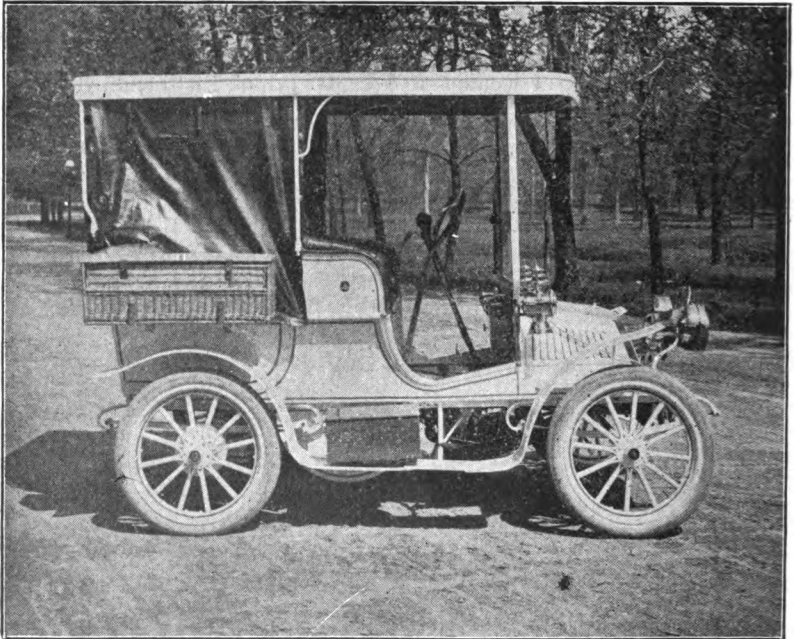

===== T H E =====  
**FIRST Machine equipped with a TOP, GLASS FRONT  
and SHIFTING SEARCH LIGHT made in America.**

There are now a great number.

Evidently our designs and ideas have merit.

DYKE'S Flexible Reachless Angle Iron Frame type of Running Gear is used under all cars.

Were you to follow up our advertisements, etc., for the last four or five years, you would find that practically all of our material is **original** and every new device or design that we have contributed to the advancement of the Automobile industry has been instantly adopted by others. Surely there must be merit in our devices.



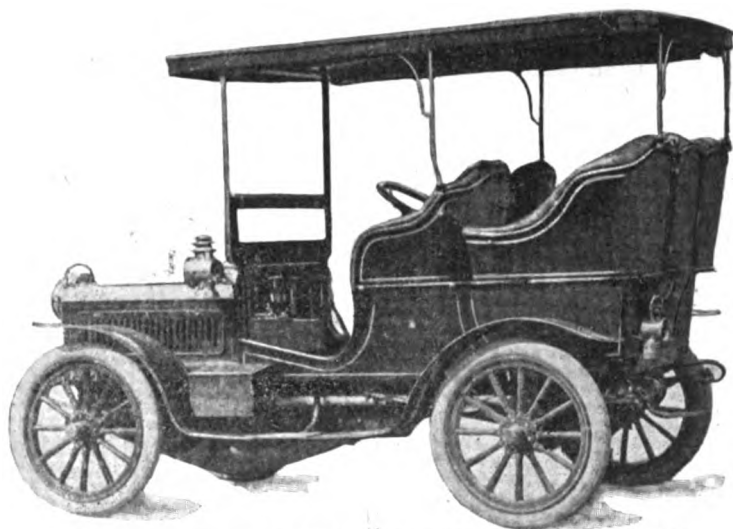

Made up from above 12 H. P. Engine. Price, \$1,250.

### **DYKE'S LATEST "OUTFIT."**

The canopy top car illustrated is a new one assembled from the most recently evolved complete "outfit" of parts furnished by the A. L. Dyke Automobile Supply Co., 2108 Olive St., St. Louis, Mo. It is the largest car ever produced by this company, being a 1,600-pound rig with 8-foot wheel base, 12-horse power, double-cylinder motor and sliding gear transmission, and being withal an up-to-date imitation of the popular style of high powered European car.

The transmission from the motor is through a fly wheel clutch of the standard cone variety and from the transmission gear to a counter shaft through bevel gears. The final drive is by a single chain from the projecting end of the enclosed counter shaft to the live rear axle. The three forward speeds and the reverse drive are controlled by small hand levers on the steering wheel column.

The water circulating system includes a regular Dyke circulating pump and continuous tube radiator. The water tank is directly behind the latter. The carburetter is, of course, the regular Dyke carburetter. The wheels are 32 inches in diameter and are fitted with  $3\frac{1}{2}$ -inch double tube tires. The oiling is by means of a multiple feed lubricator on the dash board, which oils both cylinders and the crank case. All of the bearings are lubricated by one compression grease cup.

The body is of stylish design with large detachable tonneau, curtained canopy top and glass front. The latter may be raised or lowered while the machine is in motion and the entire top is readily detachable. The bonnet is of the popular square pattern with beveled corners. The car is finished in dark blue, striped with gold.

## DISEASES OF A GASOLENE AUTOMOBILE

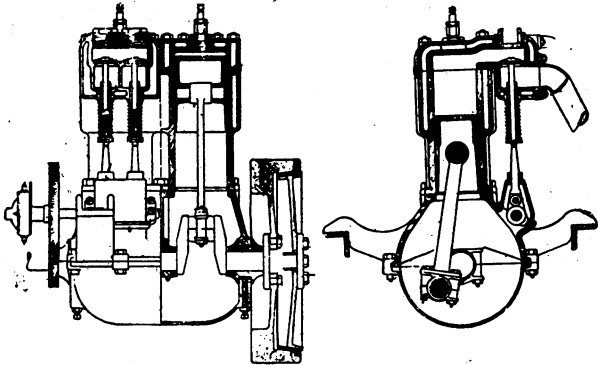

**Dyke's 12 Horse Power Double Cylinder**

**Vertical Type, Automobile Gasoline Engine complete with friction in flywheel, carburetter attached, plug, coils, battery, wire and switch.**

This engine is patterned after one of the best foreign types of engines and the base is aluminoid, mechanically operated valves, bore  $4\frac{1}{4}$ , stroke  $5\frac{1}{4}$ . The greatest bargain in the world. See page — for machine made up with this engine.

We furnish all the parts for building a complete machine.  
**Price, engine complete as above and as per illustration \$195.00**

### **3 Speed and Reverse Sliding Gear Transmission**

To go with this engine, aluminoid case, extra.

**A. L. DYKE AUTO SUPPLY CO., St. Louis.**

AND HOW TO CURE THEM.

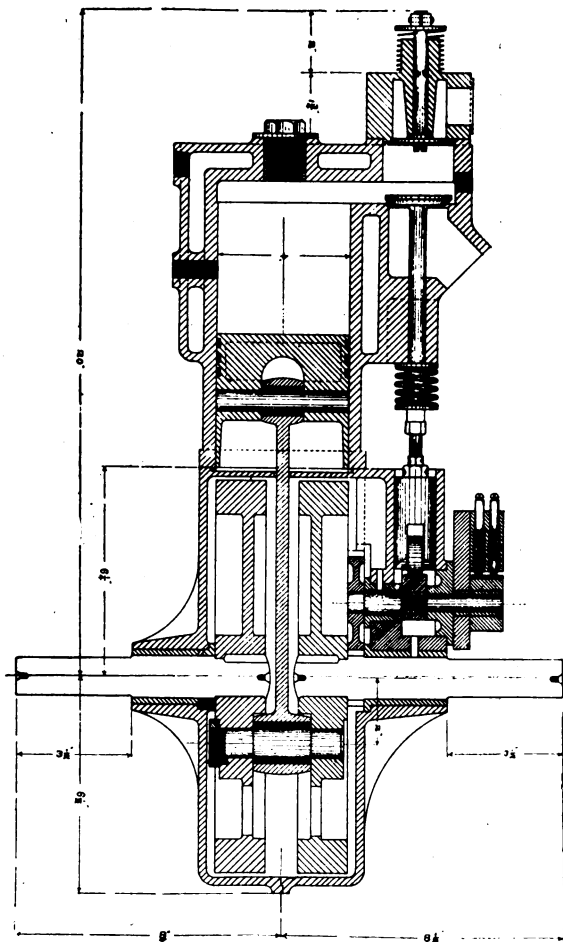

**Dyke's No. 0 Engine.**

**4 H. P., with iron or aluminoid base. We sell the Castings or Complete.**

**A. L. DYKE AUTO SUPPLY CO., ST. LOUIS, MO.**



**DYKE'S LIST of  
SECOND HAND  
AUTOMOBILES  
ARE ALL BARGAINS**

**WHY?**

Because we pick from a large assortment.

Because all machines we sell are tested by a competent mechanic.

Because we could not risk losing the reputation which we have gained by years of hard work in sending you a misrepresentation.

If you are looking for a good machine, and do not mind getting one that has been used, which is oftentimes better than new, then send for our list.

If you do not want a machine and know of anyone who does, kindly refer them to us.

To parties having machines to sell, will say that we will sell your machine if you will send it to us on consignment and make a reasonable price. If your machine is not up-to-date and will not stand a thorough test, it will not pay you to ask us to sell it.

WE WERE the first concern in America to advertise second-hand Automobiles. We have been selling them for a long time and have never displeased a customer. We have testimonials from them all.

**A. L. DYKE**

1402 Pine St.

St. Louis, Mo.

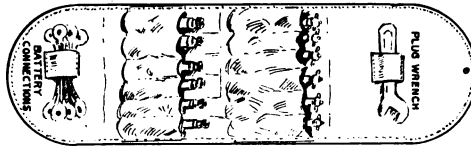

PLUG CASE OPENED



PLUG CASE CLOSED

**DYKE'S PLUG CASE, \$.....**

Extra for 1 Dozen Battery Connections and Plug Wrench, \$0.75

Select your Plugs on Page .....

# MACHINE MADE UP FROM DYKE'S No. 1 OUTFIT.



Showing One-half of Front Raised.

There was only **one** machine in America offering a Tonneau at the time **Dyke's No. 1 A Outfit** was put on the market.

This Outfit was a Tonneau Type Machine.

If our ideas are good, then our material must be good.

**A. L. DYKE AUTO SUPPLY CO.,**  
**ST. LOUIS, U. S. A.**

# Dyke Collapsible Rubber Bucket.

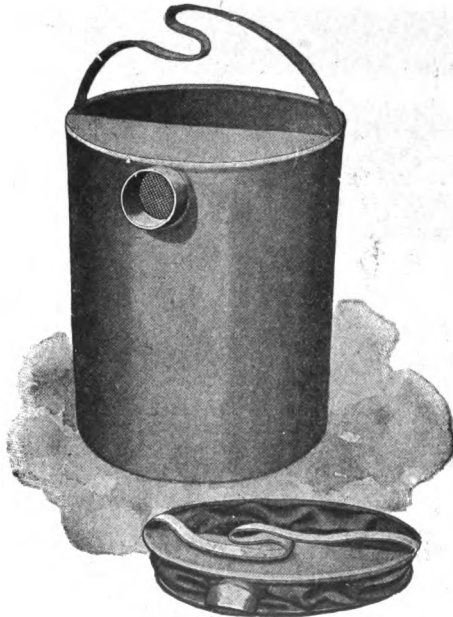

A necessary adjunct to all automobiles.

Folds up (out of the way) in small compact shape. Fitted with gravel screen.

Each  
 A Grade Rubber, **3.00**  
 B Grade Rubber, **2.60**  
 Canvas ..... **2.00**



GASOLINE STRAINER



70 MESH GAUZE

Dyke small copper Funnel with vent tube and water proof strainer for Gasoline.

Price..... **\$0.60**

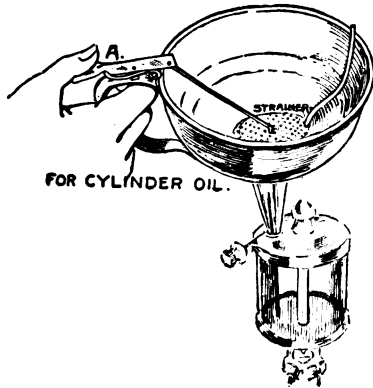

FOR CYLINDER OIL.

## DYKE'S FUNNEL

For Cylinder and Lubricating Oil.  
 Copper, Price..... **\$1.50**



Dyke's Combination Funnel  
 For gasolene or water.  
 Small, compact, oval shape.

Price..... **\$1.00**

IF YOU LIKE  
THIS BOOK

You Should  
Tell Your  
Friends.

We Will  
Appreciate  
The Favor.





**What Might Have Been.**





UNIVERSITY OF MICHIGAN



3 9015 00205 7589

Digitized by Google

