



This is a digital copy of a book that was preserved for generations on library shelves before it was carefully scanned by Google as part of a project to make the world's books discoverable online.

It has survived long enough for the copyright to expire and the book to enter the public domain. A public domain book is one that was never subject to copyright or whose legal copyright term has expired. Whether a book is in the public domain may vary country to country. Public domain books are our gateways to the past, representing a wealth of history, culture and knowledge that's often difficult to discover.

Marks, notations and other marginalia present in the original volume will appear in this file - a reminder of this book's long journey from the publisher to a library and finally to you.

### **Usage guidelines**

Google is proud to partner with libraries to digitize public domain materials and make them widely accessible. Public domain books belong to the public and we are merely their custodians. Nevertheless, this work is expensive, so in order to keep providing this resource, we have taken steps to prevent abuse by commercial parties, including placing technical restrictions on automated querying.

We also ask that you:

- + *Make non-commercial use of the files* We designed Google Book Search for use by individuals, and we request that you use these files for personal, non-commercial purposes.
- + *Refrain from automated querying* Do not send automated queries of any sort to Google's system: If you are conducting research on machine translation, optical character recognition or other areas where access to a large amount of text is helpful, please contact us. We encourage the use of public domain materials for these purposes and may be able to help.
- + *Maintain attribution* The Google "watermark" you see on each file is essential for informing people about this project and helping them find additional materials through Google Book Search. Please do not remove it.
- + *Keep it legal* Whatever your use, remember that you are responsible for ensuring that what you are doing is legal. Do not assume that just because we believe a book is in the public domain for users in the United States, that the work is also in the public domain for users in other countries. Whether a book is still in copyright varies from country to country, and we can't offer guidance on whether any specific use of any specific book is allowed. Please do not assume that a book's appearance in Google Book Search means it can be used in any manner anywhere in the world. Copyright infringement liability can be quite severe.

### **About Google Book Search**

Google's mission is to organize the world's information and to make it universally accessible and useful. Google Book Search helps readers discover the world's books while helping authors and publishers reach new audiences. You can search through the full text of this book on the web at <http://books.google.com/>

**B** 1,298,244

PROPERTY OF

*The  
University of  
Michigan  
Libraries*

1817

ARTES SCIENTIA VERITAS

---









ENGINEERING EDUCATION SERIES

# AUTOMOTIVE IGNITION SYSTEMS

PREPARED IN THE  
EXTENSION DIVISION OF  
THE UNIVERSITY OF WISCONSIN

BY

**EARL L. CONSOLIVER, M. E.**

SOMETIME ASSISTANT PROFESSOR OF MECHANICAL ENGINEERING  
THE UNIVERSITY OF WISCONSIN

AND

**GROVER I. MITCHELL, B. S.**

ASSISTANT PROFESSOR OF MECHANICAL ENGINEERING  
THE UNIVERSITY OF WISCONSIN

FIRST EDITION

McGRAW-HILL BOOK COMPANY, Inc.

NEW YORK: 370 SEVENTH AVENUE

LONDON: 6 & 8 BOUVERIE ST., E. C. 4

1920

**171**



Engine

TL

213  
C75

COPYRIGHT, 1920, BY THE  
MCGRAW-HILL BOOK COMPANY, INC.

THE MAPLE PRESS YORK PA

## PREFACE

This volume has been prepared to satisfy the demand for a systematic course of study dealing with the ignition systems used on automobiles, trucks, tractors, and airplanes. In preparing the text the authors have had in mind the needs of the men who have to install, adjust, and repair ignition systems in the factory and repair shop, as well as the needs of the automobile owner who desires a better understanding of the principles and construction of the modern ignition system. A few systems have been included which are no longer manufactured but many of which are still to be found in operation.

The authors wish to express their appreciation of the help and constructive criticism of Professor Ben G. Elliott; the help of Mr. Lawrence E. Blair in the preparation of many of the drawings; and the coöperation of many of the manufacturers of the equipment described.

THE UNIVERSITY OF WISCONSIN,  
MADISON, WISCONSIN.  
*October 1, 1920.*

G. I. M.  
E. L. C.

368632



# CONTENTS

	PAGE.
PREFACE . . . . .	v
CHAPTER I. PRINCIPLES OF ELECTRICITY AND MAGNETISM	
ART.	
1. Electricity . . . . .	1
2. Hydraulic Analogy of the Electric Current . . . . .	1
3. Conductors and Non-conductors . . . . .	2
4. Resistance . . . . .	2
5. Effect of Temperature on Electrical Resistance . . . . .	4
6. Relation between Current, Voltage, and Resistance . . . . .	4
7. Series Circuits . . . . .	6
8. Parallel Circuits . . . . .	6
9. Electrical Power . . . . .	8
10. Effects of Electric Current . . . . .	8
11. Magnetism . . . . .	9
12. Natural and Artificial Magnets . . . . .	9
13. Magnetic and Non-magnetic Metals . . . . .	10
14. The Poles of a Magnet . . . . .	10
15. The Magnetic Field . . . . .	12
16. Electromagnetism . . . . .	12
17. The Electromagnet . . . . .	14
18. To Determine the Polarity of an Electromagnet . . . . .	14
19. Electromagnetic Induction . . . . .	15
CHAPTER II. IGNITION BATTERIES	
20. Primary and Secondary Batteries . . . . .	19
21. The Dry Cell . . . . .	20
22. Testing Dry Cells . . . . .	22
23. Wiring of Ignition Batteries . . . . .	23
24. Care of Dry Cells . . . . .	25
25. Storage Cells . . . . .	25
26. The Edison Storage Battery . . . . .	25
27. The Lead Storage Battery . . . . .	27
28. Separators . . . . .	31
29. The Electrolyte . . . . .	33
30. The Hydrometer . . . . .	34
31. Action of the Lead Storage Cell on Discharge . . . . .	35
32. Action of the Lead Storage Cell on Charge . . . . .	36
33. Heat Formed on Charge and Discharge . . . . .	36
34. Evaporation of Water . . . . .	37
35. Necessity of Adding Pure Water . . . . .	37
36. Storage Battery Testing . . . . .	37
37. Variations in Cell Readings . . . . .	38

ART.	PAGE
38. Variation in Hydrometer Readings Due to Temperature Changes . . . . .	39
39. Capacity of a Storage Battery . . . . .	40
40. Battery Charging . . . . .	41
41. Detailed Instructions for Battery Charging . . . . .	42
42. Sulphation . . . . .	44
43. Effect of Overfilling . . . . .	46
44. Corroded Terminals . . . . .	46
45. Disintegrated and Buckled Plates . . . . .	47
46. Sediment . . . . .	48
47. Care of Storage Batteries in Winter . . . . .	49
48. Conditions Causing the Battery in the Electrical System to Run Down . . . . .	49

### CHAPTER III. THE JUMP-SPARK IGNITION SYSTEM

49. Requirements of Automotive Engine Ignition . . . . .	51
50. Make-and-break and Jump-spark Ignition . . . . .	52
51. The Low-tension Coil for Make-and-break Ignition . . . . .	52
52. The Induction Coil . . . . .	53
53. Coil Impregnation . . . . .	55
54. Operation of the Simple Jump-spark Ignition System . . . . .	56
55. The Condenser . . . . .	57
56. The Safety Gap . . . . .	59
57. Spark Plugs . . . . .	59
58. The Vibrating Induction Coil . . . . .	64
59. The Three-terminal Coil . . . . .	65
60. The Vibrating Type Ignition System . . . . .	65
61. Timers . . . . .	66
62. Master Vibrators . . . . .	67
63. Spark Advance and Retard . . . . .	69
64. Principles of Ignition Timing . . . . .	69

### CHAPTER IV. MODERN BATTERY IGNITION SYSTEMS

65. Construction of a Typical Battery Ignition System . . . . .	73
66. The Breaker . . . . .	75
67. The Distributor . . . . .	76
68. The Resistance Unit . . . . .	77
69. Effect of the Resistance Unit upon Ignition . . . . .	77
70. Automatic and Manual Spark Advance . . . . .	78
71. The Atwater-Kent Ignition System, Type K-2 . . . . .	79
72. The Atwater-Kent Ignition System, Type CC . . . . .	84
73. The Connecticut Battery Ignition System . . . . .	88
74. The Remy Ignition System . . . . .	94
75. The Remy-Liberty Ignition Breaker for U. S. Military Truck, Class B . . . . .	98
76. The North East Battery Ignition System . . . . .	98
77. The Delco Ignition System . . . . .	101
78. The Westinghouse Ignition Systems . . . . .	103
79. The Philbrin Ignition System . . . . .	107
80. Wagner Ignition System . . . . .	111
80-A. Timing Battery Ignition with the Engine . . . . .	115
81. Care of Battery Ignition Systems . . . . .	116

## CONTENTS

ix

### CHAPTER V. BATTERY IGNITION SYSTEMS FOR MULTIPLE CYLINDER ENGINES

ART.	PAGE
82. Firing Order of Four- and Six-cylinder Engines . . . . .	117
83. Firing Order of Eight-cylinder Engines . . . . .	119
84. Determining the Firing Order of an Eight-cylinder Engine . . . . .	121
85. The Delco Ignition System for the Oldsmobile Eight . . . . .	121
86. The Delco Ignition System for the Cadillac Eight . . . . .	122
87. Firing Order of Twelve-cylinder Engines . . . . .	127
88. The Delco Ignition System for the Packard Twin Six . . . . .	129
89. Delco Ignition for Pierce-Arrow Dual Valve Six . . . . .	132
90. Ignition Requirements of Liberty Twelve Aircraft Engines . . . . .	135
91. The Delco Ignition System for Liberty Twelve Aircraft Engines . . . . .	136
92. Ignition Timing on Eight- and Twelve-cylinder Engines . . . . .	141

### CHAPTER VI. THE LOW-TENSION MAGNETO

93. Magneto Classification . . . . .	143
94. Magneto Magnets . . . . .	143
95. Lines of Force . . . . .	144
96. Types of Magnets . . . . .	144
97. Mechanical Generation of Current . . . . .	145
98. Low- and High-tension Magnetos . . . . .	146
99. Armature and Inductor Type Magnetos . . . . .	147
100. Current Wave from a Shuttle Wound Armature . . . . .	147
101. Magneto Speeds . . . . .	148
102. Low-tension Magneto Ignition System with Interrupted Primary Current . . . . .	149
103. Low-tension Magneto Ignition System with Interrupted Shunt Current . . . . .	150
104. Dual Ignition Systems . . . . .	152
105. Splitdorf Low-tension Dual Ignition System with Type T Magneto . . . . .	153
106. Remy Inductor Type Magneto . . . . .	154
107. The Ford Ignition System . . . . .	157
108. Timing the Ford Ignition System . . . . .	160

### CHAPTER VII. MODERN HIGH-TENSION MAGNETOS—ARMATURE TYPES

109. The High-tension Magneto . . . . .	161
110. The Bosch High-tension Magneto . . . . .	161
111. The Bosch High-tension Dual Ignition . . . . .	170
112. The Bosch High-tension Magneto, Type NU4 . . . . .	173
113. Timing the Bosch Magneto, Type NU4 . . . . .	175
114. The Eisemann High-tension Magneto, Type G4 . . . . .	176
115. The Eisemann High-tension Dual Magneto, Type GR4 . . . . .	181
116. Timing of the Eisemann Magneto to the Engine for Variable Spark . . . . .	185
117. The Eisemann Magneto with Automatic Spark Advance . . . . .	185
118. Eisemann Impulse Starter . . . . .	187
119. Simms High-tension Dual Ignition System . . . . .	188
120. The Berling High-tension Dual Magneto . . . . .	190
121. The Kingston Model O High-tension Magneto . . . . .	192
122. The Mea Magneto . . . . .	194

### CHAPTER VIII. MODERN HIGH-TENSION MAGNETOS—INDUCTOR TYPES

123. Principles of the Inductor Type Magneto . . . . .	197
124. The K-W High-tension Magneto . . . . .	198

ART.	PAGE
125. The Dixie Magneto for Four- and Six-cylinder Engines . . . . .	205
126. The Splitdorf Aero Magneto . . . . .	209
127. The Splitdorf Aero Magneto with Impulse Starter . . . . .	214
128. The Aero Magneto with Battery Starting Connections . . . . .	216
129. The Aero Magneto for Eight-cylinder Engines . . . . .	217
130. The Aero Magneto for Twelve-cylinder Engines . . . . .	219
131. The Aero Airplane Magneto . . . . .	219
132. Aero Magneto Adjustments. . . . .	222

#### CHAPTER IX. CARE AND REPAIR OF IGNITION APPARATUS

133. Methods of Mounting Ignition Apparatus . . . . .	225
134. Magneto Couplings . . . . .	229
135. Bearings and Lubrication . . . . .	230
136. Impulse Starters. . . . .	232
137. General Rules for Magneto Timing . . . . .	232
138. General Rules for Battery Ignition Timing . . . . .	235
139. Care and Adjustment of Breakers and Timers. . . . .	236
140. Wiring and Terminals . . . . .	238
141. Wiring the High-tension System. . . . .	241
142. Testing High-tension Insulation. . . . .	242
143. Care of the Distributor . . . . .	242
144. Installation and Care of Spark Plugs. . . . .	243
145. Spark Plug Testing . . . . .	244
146. Ignition Coil Testing . . . . .	245
147. Condenser Troubles and Method of Testing. . . . .	247
148. Recharging Magnets . . . . .	249

#### CHAPTER X. IGNITION TROUBLES AND REMEDIES

149. Starting the Engine . . . . .	255
150. Failure of the Engine to Start . . . . .	255
151. Testing the Battery Ignition System . . . . .	255
152. Testing the Magneto Ignition System . . . . .	256
153. Locating a Misfiring Cylinder . . . . .	256
154. Defective Spark Plugs . . . . .	256
155. Defective Wiring and Ignition Apparatus. . . . .	257
156. Battery Ignition Breaker . . . . .	258
157. Defective Condenser . . . . .	258
158. The Resistance Unit . . . . .	258
159. Coil Adjustments . . . . .	259
160. Breakdown of Coil Wiring or Insulation . . . . .	259
161. Timers . . . . .	259
162. Improper Spark Timing . . . . .	259
↓ 163. Dry Batteries. . . . .	260
164. Storage Batteries . . . . .	260
165. Magneto Troubles . . . . .	260
166. Premature Ignition. . . . .	261
167. Effects of Faulty Ignition on Engine Operation . . . . .	261
168. Things to Remember Regarding Ignition . . . . .	262
INDEX . . . . .	263

# AUTOMOTIVE IGNITION SYSTEMS

## CHAPTER I

### PRINCIPLES OF ELECTRICITY AND MAGNETISM

1. **Electricity.**—Probably no other factor has played such an important part in making possible the modern gasoline automobile with its four-, six-, eight-, or twelve-cylinder engine than has electricity in its many applications. It may be said that the perfection of the modern automotive power plant has been brought about largely by the development of the electrical equipment. Electricity, in addition to igniting the fuel charge within the engine cylinders, is also called upon to start the engine, furnish the light, operate the horn, and, in some instances, operate cigar lighters and hand warmers, preheat the fuel charge for cold weather starting, and shift the gears of the transmission. That electricity is indispensable in the automotive field is evidenced by the fact that practically all makes of passenger automobiles, as well as many trucks and tractors, are completely equipped with electric starting, lighting, and ignition systems.

Since the successful operation of the automobile depends so greatly upon its electrical equipment, it is essential that this equipment be operated properly and kept in the best of adjustment and repair. In order that this may be done successfully, it is necessary that a clear understanding be had of the fundamental electrical and electromagnetic principles underlying the construction and operation of the electrical equipment used. The exact nature of electricity is not known; but its effects, the laws governing its action, and the methods of controlling it and using it for doing various kinds of work are well understood.

The electric current used in the electrical equipment on the automobile may be generated in either of two ways. One of these is by *chemical action*, the principle employed in batteries, and the other is by the conversion of mechanical energy into electrical energy by means of *electromagnetic induction*. This is the method used in the magneto and in the generator.

2. **Hydraulic Analogy of the Electric Current.**—An electric current flowing through a wire may be compared to a stream of water flowing through a pipe. Just as water will flow through a pipe, due to pressure from a pump or a difference in level, such as from *A* to *B* in Fig. 1, so



electric current will flow through a conductor, due to an *electrical pressure* or *potential* created by a battery or a mechanically driven generator. For example, if a wire is connected to the two terminals of a storage battery, as in Fig. 2, a current will flow through the wire from the *high potential* or *positive (+)* terminal to the *low potential* or *negative (-)* terminal as indicated by the arrows. The pressure causing the water to flow is measured in pounds per square inch and the rate of flow in gallons per unit of time, while in the electric circuit the pressure or *electromotive force* is measured in units called *volts* and the rate of current flow in *amperes*.

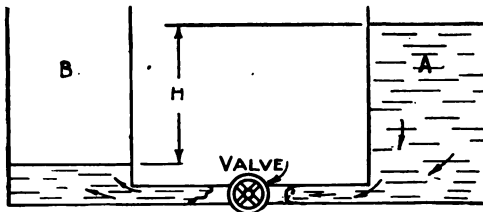

FIG. 1.—Hydraulic analogy of electric current.

force is measured in units called *volts* and the rate of current flow in *amperes*.

**3. Conductors and Non-conductors.**—All substances conduct electricity to some extent, some much better than others. There is no known substance which does

not offer some resistance to the flow of electric current through it. Materials such as silver, copper, etc., which offer a comparatively low resistance, are known as *conductors*, while materials such as porcelain, glass, fiber, rubber, etc., which offer a high resistance to the passage of current, are known as *non-conductors* or *insulators*. Liquids which offer a low resistance to the passage of current are known as *electrolytes*, while liquids which offer a high resistance are known as *non-electrolytes*.

**4. Resistance.**—The opposition which a substance offers to the passage of an electric current through it is the *resistance* of that substance, and the unit of this electrical resistance is called the *ohm*. The *ohm* may be defined as the resistance of a circuit in which one ampere of current flows under one volt pressure. The resistance of a circuit may be compared to the friction

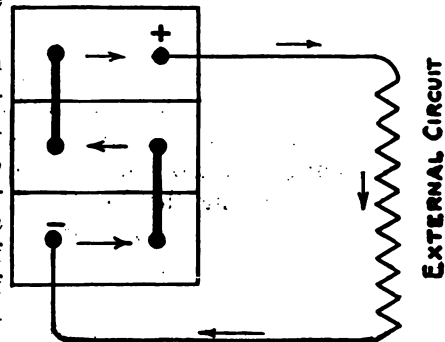

FIG. 2.—Battery electric circuit.

offered by a pipe to the flow of a liquid, in that the electrical resistance of the circuit depends upon the *size, length, material, and temperature* of the conductor, just as the flow of any liquid is resisted by friction which in turn depends upon the size and length of the pipe, the material or kind of pipe (whether smooth, rough, straight, or crooked), and upon the temperature of the liquid. Thus it is evident that the size of a certain wire determines the amount of current it can carry at a given voltage without excessive heating. A small wire can naturally conduct a small

RESISTANCE OF STANDARD ANNEALED COPPER WIRE, AMERICAN WIRE GAGE (BROWN & SHARPE)

Gage No. (B. & S.)	Actual diam. of wire in inches	Nominal diam. inches	Feet per pound (bare wire)	Ohms per 1,000 feet	
				20 deg. Cent. (= 68 deg. Fahr.)	50 deg. Cent. (= 122 deg. Fahr.)
0000	0.4600	1 $\frac{5}{32}$	1.561	0.04901	0.05479
000	0.4096	1 $\frac{3}{32}$	1.968	0.06180	0.06909
00	0.3648	2 $\frac{3}{64}$	2.482	0.07793	0.08712
0	0.3249	2 $\frac{1}{64}$	3.130	0.09827	0.1099
1	0.2893	1 $\frac{9}{64}$	3.947	0.1239	0.1385
2	0.2576	$\frac{1}{4}$	4.977	0.1563	0.1747
3	0.2294	$\frac{7}{32}$	6.276	0.1970	0.2203
4	0.2043	1 $\frac{3}{64}$	7.914	0.2485	0.2778
5	0.1819	...	9.980	0.3133	0.3502
6	0.1620	$\frac{5}{32}$	12.58	0.3951	0.4416
7	0.1443	...	15.87	0.4982	0.5569
8	0.1285	$\frac{1}{8}$	20.01	0.6282	0.7023
9	0.1144	$\frac{7}{64}$	25.23	0.7921	0.8855
10	0.1019	...	31.82	0.9989	1.117
11	0.0907	$\frac{3}{32}$	40.12	1.260	1.408
12	0.0808	$\frac{5}{64}$	50.59	1.588	1.775
13	0.0719	...	63.80	2.003	2.239
14	0.0641	$\frac{1}{16}$	80.44	2.525	2.823
15	0.0571	...	101.4	3.184	3.560
16	0.0508	$\frac{3}{64}$	127.9	4.016	4.489
17	0.0453	...	161.3	5.064	5.660
18	0.0403	...	203.4	6.385	7.138
19	0.0359	...	256.5	8.051	9.001
20	0.0320	$\frac{1}{32}$	323.4	10.15	11.35
21	0.0285	...	407.8	12.80	14.31
22	0.0253	...	514.2	16.40	18.05
23	0.0226	...	648.4	20.36	22.76
24	0.0201	...	817.7	25.67	28.70
25	0.0179	...	1,031.0	32.37	36.18
26	0.0159	$\frac{1}{64}$	1,300.0	40.81	45.63
27	0.0142	...	1,639.0	51.47	57.53
28	0.0126	...	2,067.0	64.90	72.55
29	0.0113	...	2,607.0	81.83	91.48
30	0.0100	...	3,287.0	103.2	115.4
31	0.0089	...	4,145.0	130.1	145.5
32	0.0080	...	5,227.0	164.1	183.4
33	0.0071	...	6,591.0	206.9	231.3
34	0.0063	...	8,310.0	260.9	291.7
35	0.0056	...	10,480.0	329.0	367.8
36	0.0050	...	13,210.0	414.8	463.7
37	0.0045	...	16,660.0	523.1	584.8
38	0.0040	...	21,010.0	659.6	737.4
39	0.0035	...	26,500.0	831.8	929.8
40	0.0031	...	33,410.0	1,049.0	1,173.0

current, while it requires a large wire to conduct a large current at the same pressure, just as it requires a large pipe to conduct a large flow of water. In fact, it has been found that *the resistance of a conductor is directly proportional to its length and inversely proportional to its cross-sectional area.*

The resistance of a conductor depends not only upon its size and length, but also upon the kind of metal of which it is composed, since some metals are much better conductors than others. For instance, silver is a better conductor than copper, copper is much better than iron, and iron is much better than lead. Owing to the relative cheapness, low resistance, and high breaking strength of copper, it is recognized as the best all-round commercial conductor; consequently, it is used universally in the construction and wiring of automobile electrical equipment. The resistance of different sizes of annealed copper wire is given in the table on p. 3. From this table it will be noted that the resistance increases as the size of the wire decreases and increases with an increase in temperature. The change in resistance due to an increase in temperature can readily be seen by comparing the last two columns of the table.

**5. Effect of Temperature on Electrical Resistance.**—With the exception of certain metal alloys, the resistance of practically all substances varies with a change in temperature. It has been found that in the case of all metal conductors used on the automobile, such as platinum, tungsten, copper, lead, iron, etc., an increase in temperature is accompanied by an increase in electrical resistance, while in the case of insulating materials, carbon and various electrolytic solutions, an increase in temperature is accompanied by a decrease in resistance. These characteristics are important to remember in connection with the operation of the ignition resistance unit, spark plugs, carbon brushes, storage battery electrolyte, and other parts of the electrical system.

**6. Relation between Current, Voltage, and Resistance.**—It was discovered by Ohm that in the case of circuits which carry current continuously in one direction (known as direct-current circuits), a definite relation exists between the resistance of a circuit and the current which will flow under a certain voltage. This relation is known as Ohm's law and may be stated as follows: *The current strength in any circuit is directly proportional to the voltage applied to the circuit divided by the resistance of the circuit.* This law is usually expressed as: *Current equals voltage divided by resistance,* or, stating the same thing in another way,

$$\text{Amperes} = \frac{\text{Volts}}{\text{Ohms}} \text{ or } I = \frac{E}{R} \quad (1)$$

in which  $I$  = the current in amperes,  $E$  = the voltage in volts, and  $R$  = the resistance in ohms.

The formula for Ohm's law may also be transposed into other forms convenient for finding the voltage and resistance, namely:

$$\text{Volts} = \text{amperes} \times \text{ohms} \text{ or } E = IR \tag{2}$$

and

$$\text{Ohms} = \frac{\text{Volts}}{\text{Amperes}} \text{ or } R = \frac{E}{I} \tag{3}$$

Thus if the voltage and resistance, or the current and resistance, or the voltage and current are known, the exact relation between the vol-

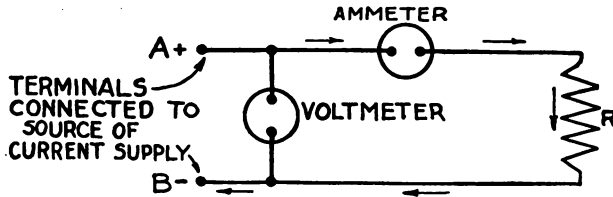

FIG. 3.—Method of connecting ammeter and voltmeter on electric circuit.

tage, current, and resistance can be readily calculated by applying the proper formula.

The voltage and current of a circuit can be readily measured by connecting a *voltmeter* and an *ammeter*, respectively, as shown in Fig. 3. Although the two instruments are usually very similar in external appearance, the voltmeter is designed to measure the electrical pressure in *volts* and is connected across the source of current supply, such as terminals *A* and *B*, Fig. 3, while the ammeter is an instrument for measuring the current flow in amperes and is connected in the circuit, Fig. 3, so that all the current flowing in the circuit passes through the instrument. The ammeter is the only one of the two instruments usually furnished on the automobile, the voltmeter being used chiefly for testing purposes. The ammeter is usually of the type shown in Fig. 4. It is located on the instrument board and is connected in the lighting and battery charging circuits so that it will indicate the amount of current either charging the battery or discharging from the battery.



FIG. 4.—Typical automobile type ammeter.

As there is no instrument for measuring directly the electrical resistance of a circuit, this must be calculated by first measuring the voltage and current as just described and dividing the voltage in *volts* by the current in *amperes* as in formula (3). A practical application of this formula may be seen in the determination of the resistance of a coil of

wire connected across the terminals of a 6-volt battery and drawing a current of 2 amperes. The resistance of the coil will be equal to 6 volts divided by 2 amperes, or 3 ohms.

If this same coil of wire were connected across a 12-volt battery, the current which it would draw would be according to formula (1), 12 volts divided by 3 ohms, or 4 amperes, or twice the amount drawn from the 6-volt battery.

When a wire consists of such material, size, length, and temperature as to offer 1 ohm resistance, the voltage required to force 1 ampere through it, according to formula (2), must be 1 volt. Thus it will be seen that *the volt or unit of electrical pressure may be defined as the pressure required to force a current of one ampere through a circuit having one ohm resistance.*

**7. Series Circuits.**—When two or more electrical devices or circuits are connected so that the same current flowing through one must also flow through the others, such as  $R_1$  and  $R_2$ , Fig. 5, they are said to be in series and the circuit is called a series circuit. The resistance of the entire circuit is the total sum of the resistances of each circuit.

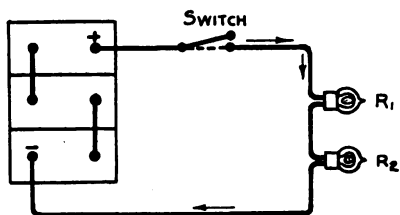

FIG. 5.—Lamps connected in series.

For example, if  $R_1$  and  $R_2$ , Fig. 5, represent two 6-volt lamps connected in series, the filament of each being of such material, size, and length as to offer 2 ohms resistance, the total resistance offered by the lamps will be  $R_1$  plus  $R_2$ , or  $2 + 2 = 4$  ohms. The current which the lamp circuit will draw from a 6-volt battery will then be according to formula (1),

$$I = \frac{E}{R} = \frac{6}{4} = 1\frac{1}{2} \text{ amperes.}$$

If the lamps connected in this manner are both of the same kind, for example, 6-volt, 18 candlepower, each will burn at one-half voltage, and, consequently, at a correspondingly reduced brilliancy.

**8. Parallel Circuits.**—When two or more circuits are connected to the same source of current supply, thus providing more than one path for the current to flow, as in Fig. 6, the circuits are said to be connected in parallel. It is evident that the more paths there are for the current to travel in, the less will be the total resistance and the greater will be the current flowing in the entire circuit. It will also be seen that the amount of current flowing in each parallel circuit will be in proportion to the resistance of that circuit. For example, if two circuits are connected in parallel, as in Fig. 7, having 10 ohms and 1 ohm resistance, respectively, the current flowing in the two circuits will be in proportion to the resistances of the two circuits or a ratio of 10 to 1. Thus if a total current of

11 amperes is flowing through the two circuits, the 10 ohm circuit will conduct 1 ampere, and the 1 ohm circuit 10 amperes.

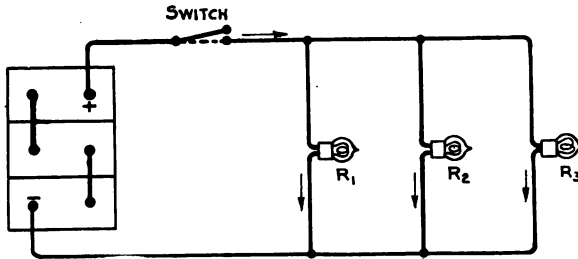

FIG. 6.—Lamps connected in parallel.

The total resistance of two or more parallel circuits may be determined from the following formula:

$$R = \frac{1}{\frac{1}{R_1} + \frac{1}{R_2} + \frac{1}{R_3} + \frac{1}{R_4} + \text{etc.}} \quad (4)$$

in which  $R_1, R_2, R_3,$  etc. represent the resistances of the various circuits connected in parallel. As an example, assume that the lamps  $R_1, R_2,$  and

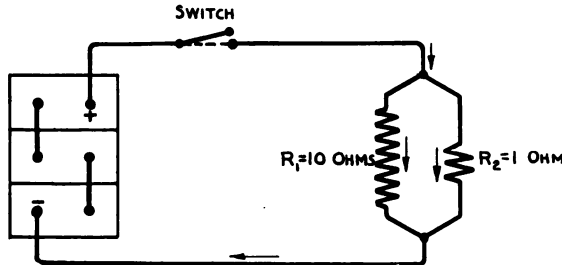

FIG. 7.—Parallel circuits.

$R_3$  in Fig. 6 have a resistance of 8, 4, and 2 ohms, respectively; then by formula (4) the combined resistance of the three lighting circuits will be,

$$R = \frac{1}{\frac{1}{8} + \frac{1}{4} + \frac{1}{2}} = \frac{1}{\frac{7}{8}} = \frac{8}{7}, \text{ or } 1.143 \text{ ohms.}$$

The total current drawn by all the lamps, if connected to a 6-volt storage battery, as shown, can now be found by formula (1),

$$I = \frac{E}{R} \text{ or } \frac{6}{1.143} = 5.25 \text{ amperes.}$$

By connecting the lamps in parallel, each lamp will operate at the same voltage (the voltage of the battery) and independent of the other lamps so that if one lamp is turned off, or burned out, the other lamps

will not be affected, but will continue to burn with full brilliancy. This, however, would not be the case if the lamps were connected in series as in Fig. 5, since the burning out of one lamp would "open" the entire circuit and prevent the current from flowing through the other lamp.

**9. Electrical Power.**—The unit of electrical power is the *watt* which may be defined as the rate at which work is performed by a current of 1 ampere flowing through a circuit under 1 volt pressure. Expressing this as a formula:

$$P = E \times I \quad (5)$$

in which  $E$  = the voltage in volts,  $I$  = the current in amperes, and  $P$  = the power in watts.

Thus it will be seen that if the voltage and current in a circuit are known, the electrical power in watts may be readily determined by multiplying the voltage in volts by the current in amperes. If the primary circuit of an automobile ignition system draws a continuous current of  $2\frac{1}{2}$  amperes from a 6-volt battery (as indicated by the dash ammeter) the electrical power or work required of the battery will be  $P = E \times I$ , or  $6 \times 2\frac{1}{2} = 15$  watts.

In many instances the watt is too small a unit for convenient use; consequently, the kilowatt (kw.) or 1,000 watts is frequently used. It requires 746 watts to equal 1 mechanical horsepower (hp.); therefore,

$$1 \text{ kw.} = \frac{1000(\text{watts in 1 kw.})}{746(\text{watt sin 1 hp.})} \text{ or } 1.34 \text{ hp.}$$

and

$$1 \text{ hp.} = \frac{746 (\text{watts in 1 hp.})}{1000(\text{watts in 1 kw.})} \text{ or } .746 \text{ kw.}$$

Approximately, 1 kilowatt equals  $1\frac{1}{3}$  horsepower, and conversely, 1 horsepower equals  $\frac{3}{4}$  kilowatt. These figures, representing the relation between mechanical and electrical power, will be found very necessary in calculating the power requirements of motors and generators; consequently, it is advisable that they be memorized. It should also be remembered that,

1 kilowatt of power used for 1 hour = 1 kilowatt hour (kw. hr.) and  
1 ampere of current used for 1 hour = 1 ampere hour (amp. hr.)

**10. Effects of Electric Current.**—Experiments have shown that an electric current in flowing through certain circuits produces various *physical, chemical, and magnetic* changes or effects. On the automobile, these effects include (1) *heat and light*, as witnessed in the glow of the lamp filaments; (2) *chemical action*, which is the principle of the storage battery; and (3) *magnetism*, upon which the induction coil, magneto, generator, and starting motor all depend for their operation.

*Heat* is developed in any conductor through which electricity flows, and the temperature of the conductor is, consequently, raised. The

heat represents the loss due to the overcoming of the resistance by the current. The amount of heat developed is often very small and is not noticeable. Fuses burn out because of the heat developed in them by the current. When the current becomes excessive, the fuse wire melts and opens the circuit, protecting it from possible damage. Incandescent lamps produce light because their filaments are heated white hot by the passage of an electric current.

The *chemical* action due to an electric current may be illustrated, as in Fig. 8, by submerging the ends of two wires, connected to battery terminals, in a glass of water in which a little salt has been dissolved. The current in passing through the water will liberate a gas (chiefly hydrogen) in the form of fine bubbles which will rise particularly around the *negative* terminal. This simple

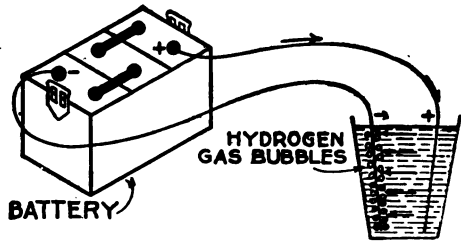

FIG. 8.—Chemical effect of electric current.

test is very valuable to remember as a means of determining the positive and negative of two direct-current leads. It is also valuable in distinguishing between alternating and direct current, since alternating current will cause bubbles to collect equally around both terminals.

The *magnetic* effect of an electric current can be readily seen when a current from a battery passes through an insulated wire wound on an iron bar as shown in Fig. 9. The iron bar then has an attraction for other pieces of iron, and is said to be magnetized.

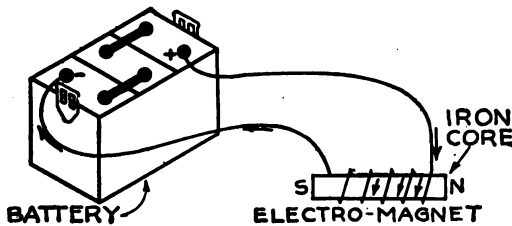

FIG. 9.—Magnetic effect of electric current.

**11. Magnetism.**—Certain metals have the property of being able to attract other metals. This property is known as *magnetism*, and, while it is not known precisely just what magnetism is, any more than it is known what electricity is, the laws

under which magnetism acts are well understood. Although *electricity* and *magnetism* are closely associated they are entirely different and one should not be confused with the other.

**12. Natural and Artificial Magnets.**—Magnetism obtained its name from the fact that certain natural iron ores found near Magnesia, in Asia, exhibited this attractive power. A piece of ore possessing this power was called a *magnet*, and the ore itself has been named *magnetite* or *lodestone*. This ore is the only known form of natural magnet. The magnetic strength of this material is not sufficient to warrant its being used



for commercial magnets. It is possible to manufacture magnets having very high magnetic strength, and these will be the only magnets which will be considered in this volume.

**13. Magnetic and Non-magnetic Metals.**—Only certain metals, chiefly iron and steel or alloys containing these metals, and nickel to a lesser extent, show magnetic properties. These metals are known as *magnetic* metals. Metals such as brass, copper, aluminum, or zinc, which do not show magnetic properties, are called *non-magnetic* metals.

Soft iron is very easily magnetized, but it loses its magnetic properties soon after the magnetizing influence is removed. Magnets made of soft iron are called *temporary* magnets. A bar of hardened steel, on the other hand, after being magnetized will, with proper treatment, retain its magnetism indefinitely. Magnets made of this material are called *permanent* magnets. For these reasons, magnets which must become demagnetized quickly, such as the cores of induction coils, are made of soft iron—usually in the form of a bundle of soft iron wires—while magnets which must retain their magnetic strength, such as the magnets on a magneto, are made of hardened nickel steel, chrome steel, or tungsten steel.

**14. The Poles of a Magnet.**—Certain parts of a magnet possess the power of attracting iron to a much greater extent than other parts. These parts are called *poles*. In a bar magnet the strength is greatest at the ends; consequently, the ends form the poles. These poles differ from each other in certain respects and are called the *North* and the *South* poles.

The force which draws bits of iron or steel to the magnet is said to be exerted along lines which extend from one pole of the magnet through the surrounding space to the other pole. These lines are called *magnetic lines of force*. The number of lines of force present in any particular part of the space, called the *magnetic field*, around a magnet constitutes the magnetic *flux* at that particular point. The lines of force are invisible but their presence may be easily shown by placing a sheet of paper over a magnet and sprinkling fine iron filings upon the paper. Upon gently tapping the paper, the filings will arrange themselves in well-defined lines running from one pole to the other as shown in Fig. 10. It will be noticed that each line runs from one pole to the other in the shortest path possible without touching its neighbor. In this respect they act very much like stretched rubber bands tending to contract as much as possible, but having a marked aversion to touching each other.

In order to explain many of the phenomena which are taken up later it is necessary to assign *direction* to the lines of force. It is now generally considered that the lines of force *leave* the magnet at the North pole, go around through space and *enter* the magnet at the South pole, continuing through the body of the magnet to the starting point. Each line of

force makes a complete loop. An interesting point in the study of the action of lines of force lies in the fact that they never *touch* each other and never *cross* each other, however crowded they may be. The direction of the lines of force of a bar and a horseshoe magnet is clearly shown in Fig. 11.

When two magnets are brought together, it is found that the North pole of one attracts the South pole of the other, and that two like poles, either North and North or South and South, repel each other. This magnetic attraction or repulsion is clearly shown by dipping two horseshoe magnets in iron filings and noting the formation of the filings when the poles of the magnets are brought together as in Fig. 12. The filings will form in metallic strings between

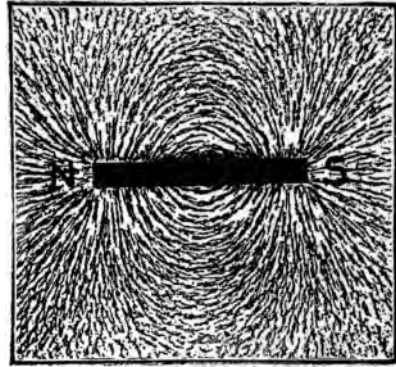

Fig. 10.—Field of a bar magnet as shown by iron filings.

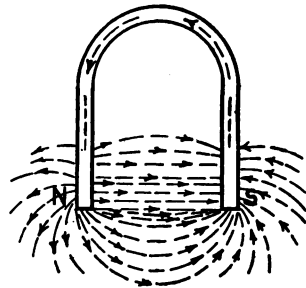
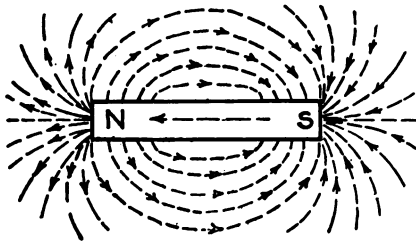

Fig. 11.—Lines of force around bar and horseshoe magnets.

the poles, thus showing the magnetic attraction between unlike poles. With the like poles brought together, as in Fig. 13, the filings will have

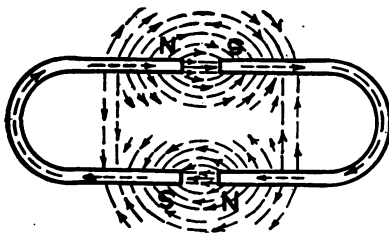

Fig. 12.—Magnetic attraction of unlike poles.

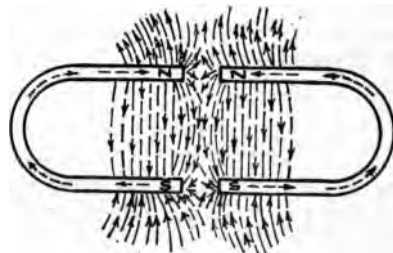

Fig. 13.—Magnetic repulsion of like poles.

the appearance of two jets of water being forced against each other, thus showing repulsion.

**15. The Magnetic Field.**—The zone through which the magnetic flux or lines of force from the North pole pass to the South pole is known as the *magnetic field* of the magnet. The strength of this field depends upon the number of magnetic lines of force per square inch at that part of the field under consideration.

The polarity of a magnet and the direction of its magnetic field may be readily determined by using a compass as shown in Fig. 14. The North

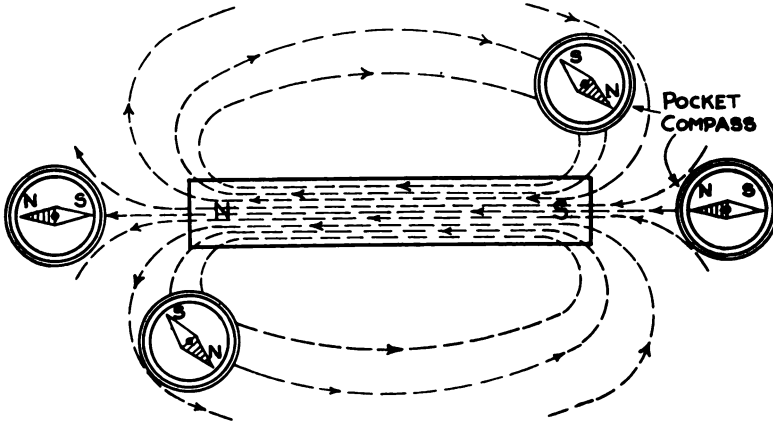

FIG. 14.—Use of a compass to determine magnetic polarity.

end of the compass needle (the end which naturally points toward the geographical North pole) will always point in the direction of the magnetic lines of force or toward the South pole of the magnet. Likewise, the south end of the compass needle will point toward the North pole of the magnet.

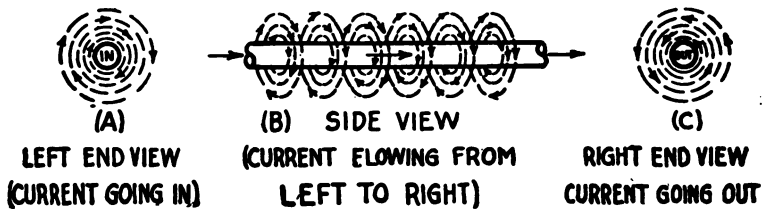

FIG. 15.—Magnetic lines of force about a straight conductor carrying current.

**16. Electromagnetism.**—Magnetism which is produced by an electric current is called *electromagnetism*. Experiments show that a wire or any other form of conductor which carries an electric current will have a magnetic field set up around it in a right-handed direction to the current and proportional in strength to the amount of current flowing. This fact constitutes the basis for the important relation between electricity and magnetism. The magnetic field thus produced is arranged in concentric circles around the wire, as in Fig. 15, and, like the field of a magnet, its

direction can be determined by a pocket compass. The magnetic needle, if held above or below a wire carrying a direct current, will turn cross

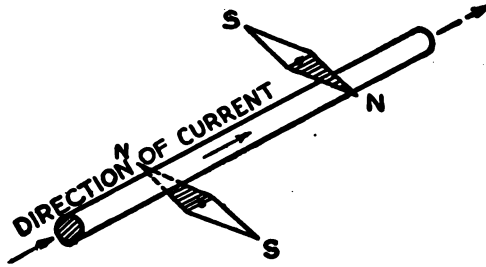

FIG. 16.—Deflection of a compass needle when near a conductor carrying a current.

wise of the wire, as in Fig. 16, with the North end of the compass pointing around the wire in the direction of the magnetic lines of force. By thus determining the direction of magnetic field around the wire, the direction of current flowing in the wire may also be determined.

If the wire is coiled into a loop, as in Fig. 17, it will be found that the lines of force all enter the same face of the loop and come out of the other face. If two loops are placed close together, as in Fig. 18 A, the lines of force will join and go around the two wires together instead of around each one alone. The same is also true of the lines of force surrounding two parallel wires placed close together in which both wires are carrying current in the same direction as in Fig. 18 B. If a number of turns of

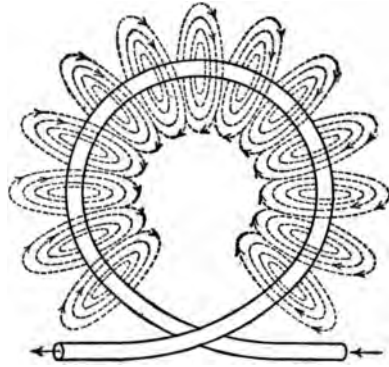

FIG. 17.—Magnetic field produced by current in a single loop.

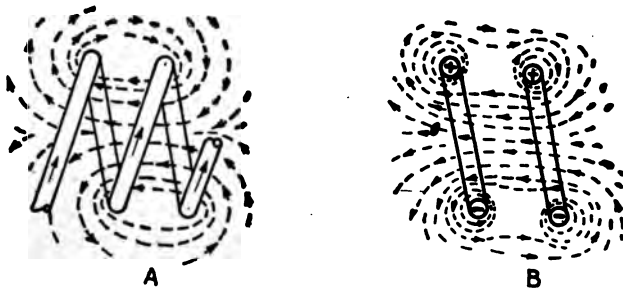

FIG. 18.—Magnetic lines of force around two adjoining loops carrying current in the same direction.

insulated wire are wound into a coil, as in Fig. 19, nearly all the lines of force will enter one end of the coil, pass through it, leave the opposite end,

and return outside of the coil to the starting point. A helical coil carrying an electric current has the same character of magnetic field as a bar magnet having a North pole where the lines of force leave the coil and a South pole where the lines of force enter the coil. Such a coil carrying an electric current is called a *solenoid*.

**17. The Electromagnet.**—The magnetic strength of a solenoid is not great, but may be made so by inserting a core of soft iron or steel, as in Fig. 20, converting it into an *electromagnet*. The iron has the property

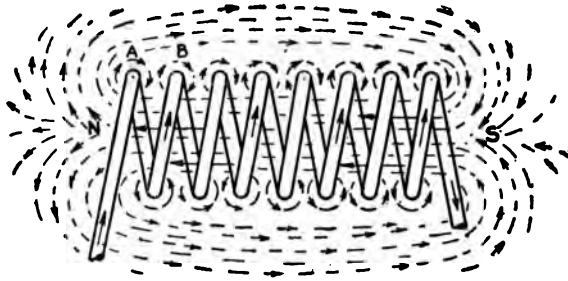

FIG. 19.—Lines of force through a coil or solenoid.

of conducting magnetic lines of force much more readily than the air; hence, a solenoid with an iron core will have greater magnetic strength than a simple solenoid without a core.

The strength of the electromagnet may also be increased by increasing either the amount of current flowing through the winding, or the number of turns in the coil, or both. In fact, the magnetic pull of the core will depend not only on the size and length of the core, but on the number of amperes multiplied by the number of turns in the winding, or the total number of *ampere-turns* producing the magnetism. If the coil in Fig. 20 consists of 10 turns of wire through which a current of 8 amperes is flowing, the magnetic strength of the core will

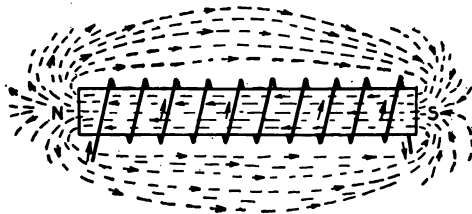

FIG. 20.—Lines of force through an electromagnet.

be due to  $10 \times 8$  or 80 ampere-turns.

**18. To Determine the Polarity of an Electromagnet.**—A simple method for determining the polarity of an electromagnet, if the direction of current is known, is to grasp the coil in the right hand with the fingers pointing around the core in the same direction as the current flowing in the winding. With the hand in this position, the thumb will naturally point in the direction of the magnetic lines of force or along the core to the North pole.

The polarity of an electromagnet may also be quickly determined by

holding a compass near its poles. The North end of the needle will point to the South pole of the magnet as already illustrated in Fig. 14.

**19. Electromagnetic Induction.**—It was pointed out in the preceding paragraphs that a current flowing in a conductor creates a magnetic field around the conductor in a right-handed direction to the flow of current as shown in Fig. 15. It will also be found that *if a magnetic field is set up around a conductor an electric current will be caused to flow in the conductor*, and that the same relation will exist between the direction of current flow and the magnetic field. This relation is shown very clearly in Fig. 21 in which the forward travel of the screw represents the direction of current, and the rotation of the screwdriver, the direction of magnetism.

The process of generating a current in this manner is known as *electromagnetic induction*, and the current thus produced is called an *induced current*. If the current is generated by magnetism alternating in direction, the induced current will also be alternating in direction, with as many reversals through the wire per second as there are reversals of

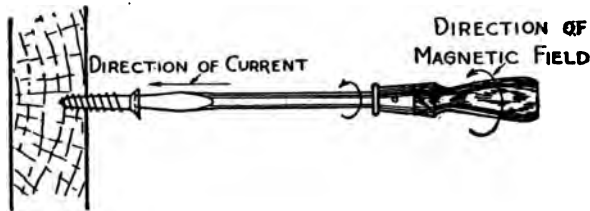

FIG. 21.—Relation between direction of current and magnetic field.

magnetism. Such a current is called *alternating current* and is usually abbreviated A. C.

A magnetic field may be set up around a wire in two ways: either by cutting a magnetic field with a wire, such as rotating an armature of a magneto or generator in a magnetic field; or by cutting the wire or coil of wire with a rapidly moving magnetic field as found in the inductor type magneto and in the induction coil.

The method by which a magnetic field is set up around a conductor and the relative direction of the induced current are illustrated by Fig. 22 *A*, *B*, and *C* in which *N* and *S* represent the North and South poles of a magnet and *W* a wire cutting through the magnetic field between *N* and *S* in a downward direction. The magnetic lines of force between *N* and *S* cause an attraction between the two poles, like that of many rubber bands under tension. It is evident that the rubber bands, if intercepted by a moving wire, will be crowded ahead as indicated in Fig. 22 *B*. In a similar way, it may be supposed that the magnetic lines of force will be distorted by the moving wire as shown in Fig. 22 *C*. From this figure it will be noted that the distorted lines of force crowding ahead of the moving conductor or wire will create a field of greater intensity on one

side of the conductor than on the other. This will have the effect of setting up a magnetic whirl around the conductor in an anti-clockwise direction, thereby inducing voltage and current in the conductor as indicated by the arrows. This whirl of magnetic lines may be likened in direction to a whirlpool caused by water turning a sharp bend in a creek, as in Fig. 23, in which the water corresponds to the magnetic lines of force.

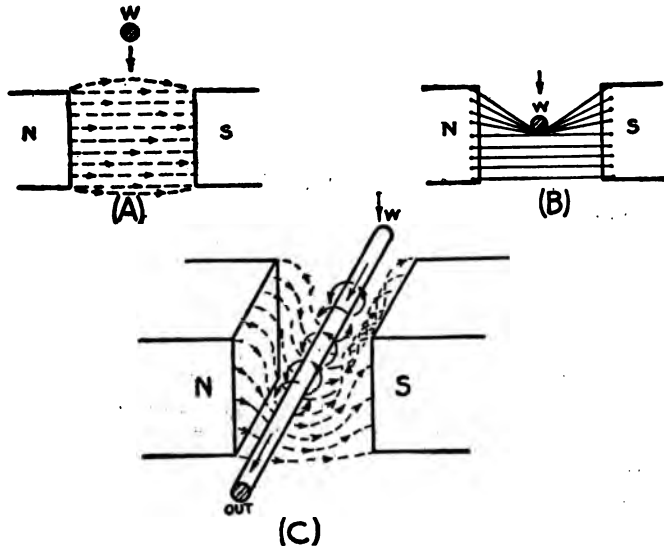

FIG. 22.—Principle of electromagnetic induction.

In this example the field was considered stationary and the wire movable. If instead the wire should be stationary and the magnetic lines made to cut the wire, as in Fig. 24, the effect would also be the same, resulting in a current and voltage being induced in the wire. In either case, the current will be set up in the wire in a direction which will



FIG. 23.—Water analogy of magnetic whirl around a conductor.

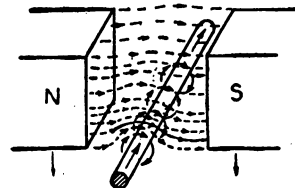

FIG. 24.—Magnetic lines of force cutting a conductor.

depend upon the direction of the magnetic lines between the poles and upon the direction in which the wire cuts the magnetic lines of force. The current thus produced is proportional in strength to the resistance of the wire, to the strength of the magnetic field, and to the speed at which the magnetic lines of force are cut.

*The Right-hand Rule.*—An easy way to determine the relation between the induced current, the direction of magnetism, and the motion of the wire through the magnetic field is by holding the thumb and first two fingers of the right hand at right angles as shown in Fig. 25. If the thumb

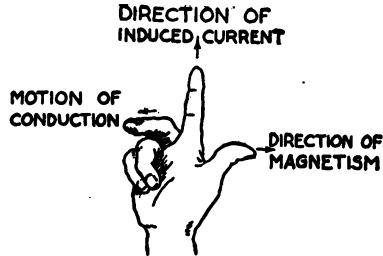

FIG. 25.—Right-hand three-finger rule for determining direction of induced current.

is made to point in the direction of the magnetic field, and the second finger in a direction corresponding to the relative motion of the conductor, the first finger will naturally point along the conductor in the direction of the induced current.





## CHAPTER II

### IGNITION BATTERIES

**20. Primary and Secondary Batteries.**—The most essential part of any electrical ignition system is the source of electric current. For this purpose a battery, generator, or magneto may be used. In the battery ignition system the current is supplied by either a dry battery made up of a number of dry cells, or by a storage battery composed of a number of storage cells. The number of cells used with either type of battery depends upon the voltage and current required to operate the system.

A *cell*, in its simplest form, consists of two plates, which may be of two different metals, or one plate may be of metal and the other of carbon, immersed in such a manner that the plates do not touch each other in a vessel containing a chemical solution called *electrolyte*. The chemical solution acts upon the plates in such a way that a difference in potential or voltage is created between the two plates. When the two plates are joined by a conductor, this pressure or voltage causes a current to flow through the conductor. Cells may be grouped under two classes; namely, *primary* and *secondary*, according to their construction and principle of operation.

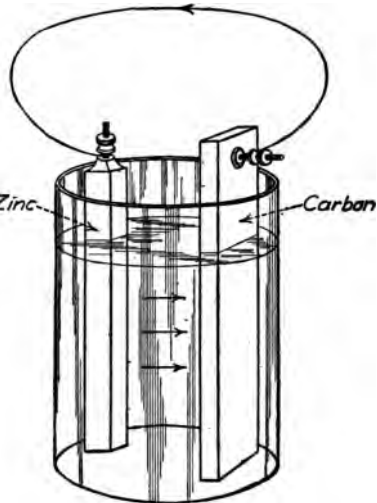

FIG. 26.—Wet primary cell.

The *primary* cell may be further classified as *wet* or *dry*, according to the nature of its electrolyte. In the wet cell, the electrolyte is in the form of a liquid, while in the dry cell it is in the form of a wet paste which will not flow or splash. An example of the wet cell is shown in Fig. 26 in which the two plates, called *elements*, of carbon and zinc are immersed in a solution of salammoniac in water. When the terminals of the cell are connected so as to form a circuit, chemical action will take place between the electrolyte and the elements, resulting in a flow of electricity through the electrolyte from the zinc to the carbon elements, and through the external circuit from the carbon terminal to the zinc terminal

and element. Such a cell, owing to its low voltage (usually about 1 volt) and the relatively small current output in proportion to its size and weight, is very inconvenient to use for automobile ignition. For this service, the *dry cell*, Fig. 27, has gained much favor, since it gives a much higher voltage and current output, namely,  $1\frac{1}{2}$  volts and 25 to 30 amperes when new, and is much more convenient to handle. The chief characteristic of any primary battery is the fact that as electrical energy is produced, one of the elements is destroyed by the chemical action. When a primary cell has become exhausted, it can be replenished only by renewing either the elements or the electrolyte, or both. In the case of dry cells it is more convenient and cheaper to replace the entire cell with a new one.

The *secondary* battery, commonly known as the *storage* battery, Fig. 40, which is now universally employed by automobile manufacturers for electric starting, lighting, and ignition purposes, differs from the primary battery in that it may be charged and discharged many times without renewing either the elements or the electrolyte. A secondary cell must first be charged by sending a direct current through it, thereby causing the elements to undergo an electro-chemical change; then, when the cell is used as a source of current, the current discharge is accompanied by a reverse chemical change which changes the elements or plates back to their original composition. Consequently, a cell of this type can be used repeatedly by providing a means of recharging when it becomes exhausted or discharged.

**21. The Dry Cell.**—The dry cell, Fig. 27, has been used very extensively in the past for passenger automobile ignition purposes and is still used extensively for tractor, truck, and stationary engine ignition, although it is being rapidly supplanted by the storage battery and magneto as a source of current. It consists of a cylindrical zinc shell or can, the inside of which is usually lined with absorbent paper saturated with a solution of salammoniac and zinc chloride. The zinc shell forms the negative terminal of the battery, and the carbon element placed in the center of the cell forms the positive terminal. The space between the absorbent paper and the carbon is filled with a mixture of crushed coke, graphite, and manganese dioxide. This mixture is also saturated with salammoniac and zinc chloride. The purpose of the crushed carbon and manganese dioxide mixture is to act as a depolarizing agent.

*Polarization.*—When a dry cell discharges rapidly, the flow of current through the electrolyte (the electrolyte is the salammoniac and zinc chloride which saturates the carbon mixture), causes hydrogen gas to be liberated. The gas accumulates in the form of bubbles around the carbon or positive element of the cell. This action is known as *polarization*. The gas thus formed tends to insulate the carbon rod from the electrolyte, thereby increasing the internal resistance and decreasing the current

output. The manganese dioxide, which is rich in oxygen, acts to depolarize or absorb this gas by the combining of the oxygen and hydrogen, forming water. If the cell discharges slowly, the hydrogen is united with the oxygen as rapidly as released. However, when the discharge rate is high, the hydrogen is released too rapidly to be taken up by the oxygen in which case the cell will polarize. If the cell is allowed to stand for a short time, to permit the hydrogen to be absorbed, it will regain its normal condition.

Nearly all American dry cells used for ignition are  $2\frac{1}{2}$  in. in diameter and 6 in. high, which size is usually referred to as No. 6. The top is sealed with a special compound to make it air- and water-tight. The entire cell, except the top, is wrapped with pasteboard to prevent the zinc making contact with other zinc cans in the set. The voltage of a

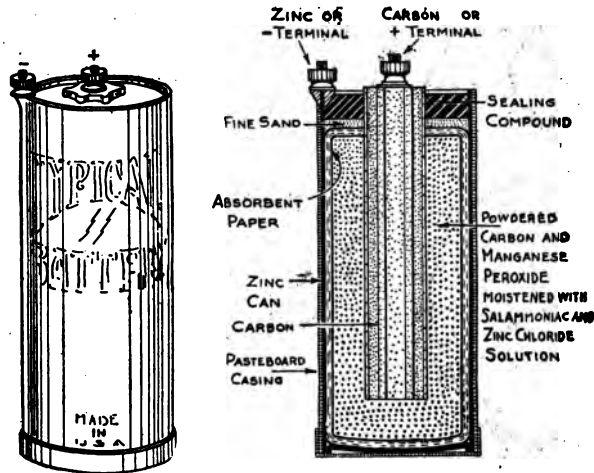

FIG. 27.—The dry cell.

good dry cell on open circuit is about  $1\frac{1}{2}$  volts. The maximum current or amperage which it will give, when new, ranges from 20 to 35 amperes, depending upon the size of the cell and the temperature. A No. 6 cell giving more than 25 to 30 amperes will probably polarize rapidly. Cell capacity and life depend largely on the way the cell is used, both being greater when it is used intermittently.

*The Dry Cell Always Gives out Direct Current.*—Not all dry cells are suitable for ignition. Cells which may be suitable for intermittent use on doorbells, annunciators, telephones, etc. may have a rather high internal resistance. By *resistance* is meant the opposition offered to a flow of current. Ignition cells should be constructed so as to have a low internal resistance. In addition to this, a special effort should be made to reduce polarization to a minimum.

**22. Testing Dry Cells.**—The voltage of a cell depends upon the kind and quality of the elements, the composition of the electrolyte, and the temperature. With identical materials, a small cell will show the same voltage as a large one. On the other hand, the amperage or capacity of a cell depends upon its size. If the terminals of a voltmeter are connected across the terminals of a new dry cell, a reading of about 1.5 volts will be recorded. The voltage of an exhausted cell is almost as high as a new one; consequently, the voltage test of a dry cell does not furnish accurate information as to its condition.

The standard method of testing dry cells is by the use of an *ammeter*. This is an instrument that indicates the rate of flow of current in amperes.



FIG. 28.—Typical pocket volt-ammeter for testing dry cells.

Figure 28 shows a combination voltmeter and ammeter, known as a *volt-ammeter*, such as is usually used for dry cell testing. The flexible terminal is in both the ammeter and voltmeter circuits. When used to test dry cells, the flexible terminal and the terminal marked Amp. are touched to the dry cell terminals, the stationary terminal being connected to the center terminal or positive and the flexible terminal to the zinc or negative. The needle will move across the scale and indicate the current strength of the cell. When new, the reading for a No. 6 ignition cell should be between 25 and 30 amperes. A reading below 8 amperes shows that the cell is nearly exhausted and cannot be considered as a reliable source of energy.

There is a perceptible difference in the action of cells at various temperatures. It is difficult for the chemical action to take place fast enough at a temperature of zero or below; consequently, the cell will test lower than at normal temperatures. On the other hand, heat stimulates the chemical action causing the cell to test higher than at normal temperatures. Heat will also cause a rapid deterioration of dry cells. When not in use, they should be stored in a cool dry place to prevent this rapid deterioration.

A rough test to determine if a cell is good can be made by short circuiting the terminals momentarily by means of a wire. If a small arc can be drawn between the wire and the carbon post, the cell is at least in fair condition. The test can also be made by stretching a piece of fine copper wire of about No. 28 or 30 gage across the terminals. If it

fuses instantly, it proves that the cell will test between 15 and 20 amp. if tested with an ammeter. Another method is to rest a knife blade on the zinc post and to touch the tip of the blade to the carbon. If a small ring of smoke appears at the point, the cell is in fair condition.

**23. Wiring of Ignition Batteries.**—When the current for ignition is supplied by a storage battery, the voltage is usually either 6 or 12 volts. This voltage is fixed by the design of the starting and lighting system which generally uses the same voltage as the ignition system and which operates from the same battery. The battery may vary in size from 60

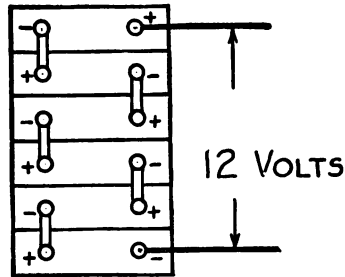
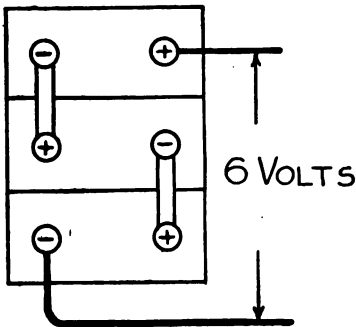

FIG. 29.—Cell connections for a six-volt storage battery.

FIG. 30.—Cell connections for a twelve-volt storage battery.

to 130 ampere-hour capacity, depending upon the requirements of the starting and lighting system. Each storage cell gives approximately 2 volts; consequently, the proper voltage may be obtained by connecting 3 cells in series; that is, connecting the *Positive* (+) terminal of one cell to the *Negative* (–) terminal of the next as shown in Fig. 29. In like manner, a 12-volt storage battery must have 6 cells connected in series as in Fig. 30.

When dry cells are used for ignition, two methods of connecting several cells may be resorted to in order to raise the voltage and amperage to



5 Dry cells in series

FIG. 31.



5 Dry cells in parallel

FIG. 32.

the proper amount, namely, through *series* or *parallel* connection. The *series* method of connection is shown in Fig. 31 in which the carbon or *Positive* of one cell is connected to the zinc or *Negative* of the next, leaving one carbon and one zinc free for connection. Thus the current has to pass through the entire set of cells to complete its circuit. This method increases the voltage as many times as there are cells. The five cells of Fig. 31, each giving about  $1\frac{1}{2}$  volts will, when connected in series,

furnish a current at  $5 \times 1\frac{1}{2}$ , or  $7\frac{1}{2}$  volts pressure. The current output is equal to the current of one cell, or about 20 amperes. If all the carbons are connected and all the zincs fastened together, as shown in Fig. 32, the connection is known as *parallel*. The resultant voltage equals the voltage of one cell, and the current output equals the current output of one cell multiplied by the total number of cells. For example, the current output of 5 cells connected in parallel would be  $5 \times 20$  or 100

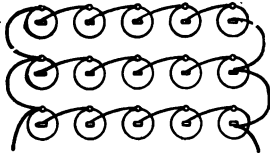

15 cells in multiple series arrangement

FIG. 33.

amperes and the voltage would be  $1\frac{1}{2}$  volts. Therefore, to increase the voltage, the cells are connected in series, and to increase the current output they are connected in parallel. Where the current demand is small or not continuous, 5 cells connected in series may be used. This arrangement gives  $7\frac{1}{2}$  volts and 20 amperes and is suitable for single cylinder engines or for starting engines of two or more cylinders where a magneto is used after the engine is in operation. It is also suitable for battery ignition systems designed so as to be very economical in the use of current.

When the amount of current required is great and a storage battery is not available, the multiple series connection may be used. This is suitable for engines of two or more cylinders and for continuous service.

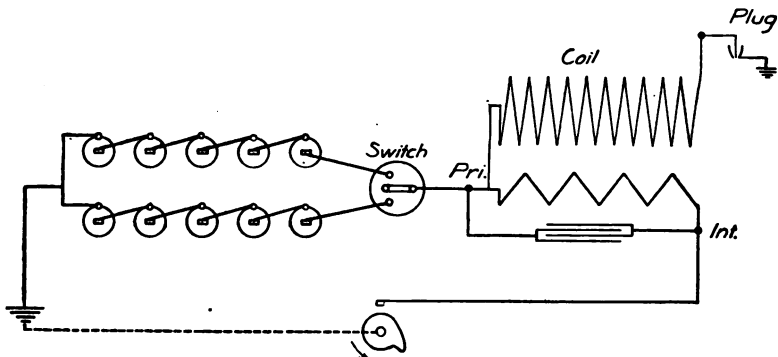

FIG. 34.—Ignition circuit with two sets of dry cells for alternate use.

The arrangement consists of parallel groups of as many cells in series as may be required for the service. Figure 33 shows an arrangement with three parallel sets, each having 5 cells connected in series. This arrangement provides for a current of about 60 amperes at  $7\frac{1}{2}$  volts.

A scheme for using two distinct sets of cells is often employed as shown in Fig. 34. By means of the three-point switch, the two sets of cells can be used alternately. This scheme allows relatively long periods for recuperation of the cells.

**24. Care of Dry Cells.**—Dry cells are subject to a trouble known as *local action*. Unless the zinc of which the container is made is very pure, chemical action will be set up between the zinc and any impurity, such as particles of iron. This chemical activity is known as local action and will cause the zinc to be rapidly destroyed. The moisture rapidly finds its way out of the openings, and as a result the cell dries out and becomes worthless.

If the cells are located in a damp place, there is a possibility of the paper covers absorbing enough moisture to set up a local circuit between the cells. This means that the cells will be continuously discharging. In order to avoid deterioration of the cells from this cause, it is advisable to avoid wet locations for the cells. Cells which must be used in such locations, however, can be protected to a great extent by being imbedded in paraffin. With this arrangement, local discharge cannot take place, neither can moisture escape through any holes in the zinc which may result from local action.

**25. Storage Cells.**—In storage cells, the current results from chemical action, as in any primary cell. When the cells are exhausted, however, they need not be discarded or the elements replaced, but instead may be restored to normal condition by passing a direct current through them. By this process, a reverse chemical change takes place, restoring the elements to their original structure. It is erroneous to say that electricity is stored in the elements of a storage cell. In reality, the storage cell is a device which converts electrical energy into chemical energy during charge, and reconverts the chemical energy back into electrical energy during discharge. The energy stored is in the form of chemical energy. When the current is drawn from the cell, the chemical action takes place, thus converting chemical energy into electrical energy.

There are two kinds of storage cells in use, the *nickel-iron* type and the *lead* type. The former consists of elements of nickel and iron compounds in a solution of caustic potash. The latter consists of two groups of lead composition plates immersed in a solution of sulphuric acid. Both types of cells may be put up in either stationary or portable form, the latter always being used for automobile purposes.

**26. The Edison Storage Battery.**—A typical Edison storage battery suitable for ignition and lighting purposes is shown in Fig. 35. This battery was developed by Thomas A. Edison in an attempt to overcome the objectionable features of the lead storage battery, such as heavy weight, acid fumes, and rapid deterioration. The plates are composed of iron and nickel, the container is nickel-plated steel, and the electrolyte is a solution of caustic potash. The top of the cell, showing the filling aperture for adding water, is shown in Fig. 36.

The complete element of the Edison cell is shown in Fig. 37. The negative plate, Fig. 38A, consists of a steel grid containing pockets filled



with iron oxide, such a pocket being shown in Fig. 38B. The positive element, Fig. 39A, consists of thirty perforated steel tubes reinforced by steel seamless rings equi-distantly spaced and mounted on a steel grid. Each perforated tube, Fig. 39B, is filled with alternate layers of nickel



FIG. 35.—Edison storage battery.



FIG. 36.—Top of Edison storage cell showing filling aperture open for adding water.



FIG. 37.—Edison cell assembled, but removed from container.

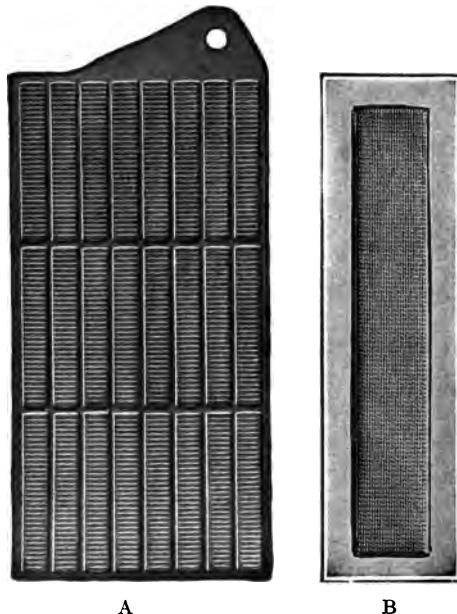

A

B

FIG. 38.—(A) Edison negative plate. (B) Pocket for negative plate. (Iron oxide).

hydrate and flake nickel. During charge and discharge, the solution of caustic potash transfers oxygen from one element to the other. The positive and negative plates are insulated by several hard rubber rods between them. The voltage of each cell is normally about 1.1 volts, the capacity depending upon the size and number of plates in the cell.

Although the Edison nickel-iron type of battery has the advantages of great mechanical strength, long life, and a relatively high capacity (at a low discharge rate) per pound of cell, it is not so well adapted for automobile service as is the lead type of battery. This is due to the lower normal voltage of the Edison cell (being about 1.1 volts per cell or approximately one-half as high as that of the lead cell), its rapid drop in voltage and efficiency in cold weather, and its inability to discharge at a high rate for the short time necessary to operate the starting motor.

Since a battery capable of giving a high current output for a short period is required to operate the starting motor, and since it must also operate under a very wide range of temperature conditions, the Edison battery is seldom used on the automobile, other than for lighting and ignition purposes. The lead storage

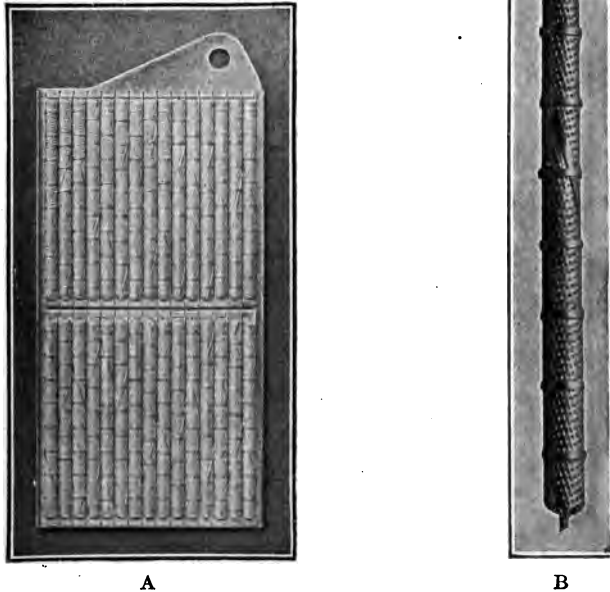

FIG. 39.—(A) Positive plate (nickel hydrate). (B) Tube for positive plate.

battery has been satisfactorily developed to meet all these requirements; consequently, it has been universally adopted by automobile manufacturers as standard equipment for starting, lighting, and ignition purposes.

**27. The Lead Storage Battery.**—A typical storage battery as used for automobile starting, lighting, and ignition purposes is shown in Fig. 40. The battery may consist of three or more cells, depending upon the voltage desired. Each cell has an electrical pressure of about 2 volts; consequently, a battery of 3 cells connected in series is known as a 6-volt battery and one of 6 cells connected in series is known as a 12-volt battery.

Each cell consists of a hard rubber jar in which is placed two kinds of lead plates known as *positive* and *negative*. These plates are separated or held apart from each other by suitable separators and are submerged in a solution of sulphuric acid and water. A sectional view of a typical lead storage cell showing the construction and arrangement of parts is shown in Fig. 41. As the lead plate storage battery produces current at a pressure of but 2 volts per cell, a single cell is rarely used. The lowest number of cells in practical use is found in the three-cell 6-volt battery, the different cells being permanently connected together by heavy lead strips, while detachable terminals are provided for connecting the battery to an outside circuit.



FIG. 40.—Typical 6-volt automobile storage battery.

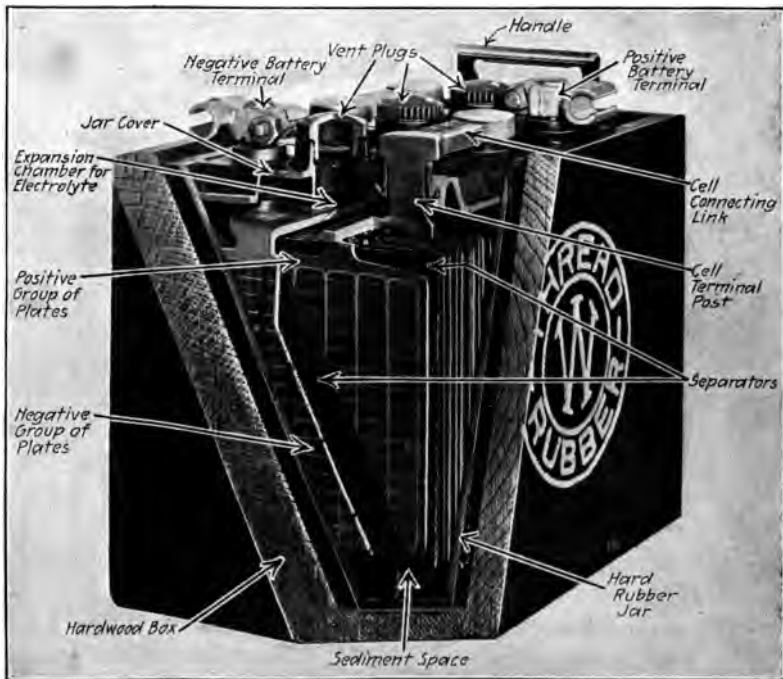

FIG. 41.—Section of typical lead storage battery.

**Plates.**—Each plate consists of a grid or framework, Fig. 42, composed of lead and antimony, the openings of which are pasted full of a lead compound known as *active material*. When dry, this active material

becomes hard like cement. The plates are then put through an electrochemical process which converts the active material of the positive plates into brown peroxide of lead, Fig. 43, and that of the negative plates into a gray spongy metallic lead as shown in Fig. 44. This process is known as *forming* the plates.

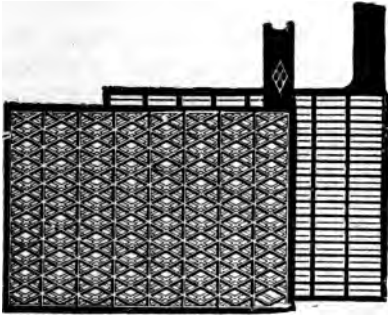

FIG. 42.—Types of grids for battery plates.



FIG. 43.—Positive plate.



FIG. 44.—Negative plate.

After the positive and negative plates have been formed, they are built into positive and negative groups as in Fig. 45. A *positive group* consists of one or more positive plates burned to a connecting strap and a *negative group* of two or more negative plates connected to a similar



FIG. 45.—Battery group.



FIG. 46.—Battery element.

connecting strap. To each strap is attached a post which is used to make electrical connection between two adjoining groups or to the starting and lighting system. One positive and one negative group, together with the separators, form an *element* as shown in Fig. 46. The negative group always has one more plate than the positive group as shown in Fig. 47.

This is true regardless of the number of plates in the element. For example, a three-plate element would have one positive and two negative plates, and a five-plate element would have two positive and three negative plates.

The plates are welded or "burned" to the connecting straps usually by a hydrogen or oxy-acetylene flame so that the plates and strap form one unit.

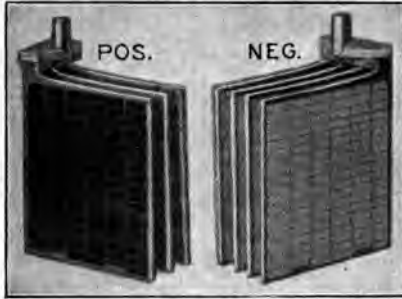

FIG. 47.—Positive and negative group.



FIG. 48.—Rubber jars.

The plates are so arranged that when the element is assembled, each positive plate surface is adjacent to a negative plate surface, the distance between these surfaces being  $\frac{3}{32}$  in. to  $\frac{1}{8}$  in. The positive and negative surfaces are kept apart by thin sheets of wood or rubber known as separators.

*Jars and Covers.*—The jars forming the cells, Fig. 41 and Fig. 48, are made of hard rubber, designed to resist both the action of the electrolyte

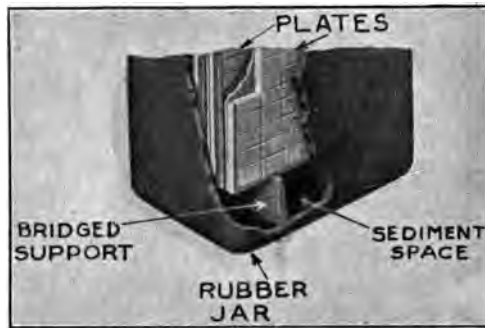

FIG. 49.—Cut away section of storage cell showing sediment space below the plates.

and the mechanical strains. Bridged supports, Fig. 49, are molded in the bottom of each jar to hold the plates and separators off the bottom, thus forming a sediment chamber below for catching the accumulation of any active material which may free itself from the plates.

The cover, Fig. 50, is of hard rubber with an opening in the center for the vent cap and an opening on each side for the connecting posts of

the positive and negative groups, which are known as terminals. The cover also provides an expansion chamber for the electrolyte.

**Battery Box.**—The battery box is made of hard wood thoroughly coated with an acid proof paint. The cells are usually sealed in place in the battery box by pouring a sealing pitch compound over the entire top. This prevents any vibration of the jars and renders the top of the cells dirt and leak proof. In some cases, where specially designed covers are used, only the individual cell tops are sealed. This adds greatly to the ease with which the battery can be taken apart.

It is absolutely essential that the battery be securely held in position on the car. For this purpose, brackets are fitted on the battery case to which bolts are attached to hold the battery firmly in position.

**Markings of the Battery.**—For convenience in connecting the battery, the terminals are ordinarily marked either with *Pos.* (+), or a red fiber sleeve on the positive post, and with *Neg.* (−), on the negative post. This marking is in accordance with the way the battery discharges, the current leaving the positive terminal and returning to the negative.

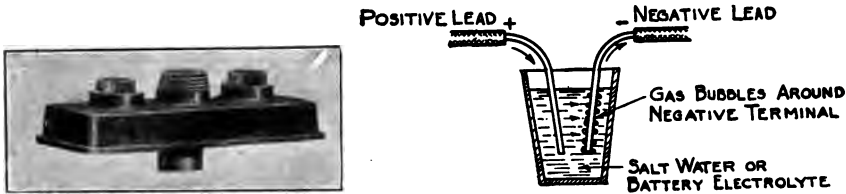

FIG. 50.—Cover for battery cell. FIG. 51.—Method of determining polarity of storage battery terminals.

It is also customary among battery manufacturers to make the positive cable connection larger than the negative. If the terminals are not marked, the polarity can be readily determined by attaching a wire lead (pronounced *lēd*) to each terminal and inserting the two free ends in a glass of salt water or battery electrolyte, whereupon gas bubbles (hydrogen) will be noticed to form around the negative lead as in Fig. 51.

**28. Separators.**—The separators play a very important part in the life and operation of the battery since they insulate the positive and negative plates from each other and prevent short circuits between them. If the separators become cracked, or damaged in any other way, permitting metallic contact between the plates, the battery will discharge internally and may ultimately become useless. Two principal kinds of separators are used, namely, *wood*, and *threaded rubber*.

The wood separator, Fig. 52, is made of specially selected wood, usually basswood or cypress, which is chemically treated to remove the acetic acid and other impurities which are always in the wood and which are harmful to the battery. This chemical treatment also makes the

wood more porous, to allow ready diffusion of the electrolyte through the separator pores upon the charging and discharging of the battery. Each separator is grooved on one side. When they are installed, this grooved side should be placed next to the positive plate with the grooves running vertical as in Fig. 53. The purpose of these grooves is to permit the gas which accumulates around the positive plate,

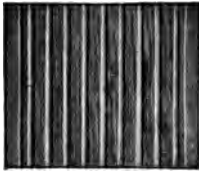

FIG. 52.—Wood separator.



FIG. 53.—Inserting separators in battery element.

which is the more active plate, to escape freely to the surface. The grooves also provide a passageway for any active material, which may free itself from the plate, to fall to the sediment space below.

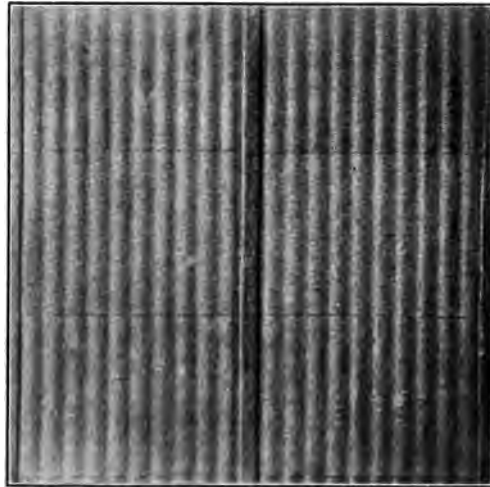

FIG. 54.—Willard threaded rubber separator.

The threaded rubber separator, Fig. 54, is manufactured by the Willard Storage Battery Company and is used exclusively in the Willard battery. From Fig. 55, which shows a magnified view of this separator, it will be seen that the threads run through the separator at right angles to the surface. According to the manufacturers, there are 196,000 of

these threads per sq. in. The theory is that each thread acts as a wick between the positive and the negative plates. The separator is thus rendered porous, due to the capillary attraction of the threads. Another feature of this separator is that it does not carbonize and crack upon drying out as does the wood separator. On this account the life of the separator and battery is greatly increased. The threaded rubber separator has corrugations which correspond to the grooves of the wood separator and should be installed in a similar manner, with the corrugations running vertical.

**29. The Electrolyte.**—The electrolyte, as used in all types of automobile lead storage batteries, consists of a mixture of chemically pure

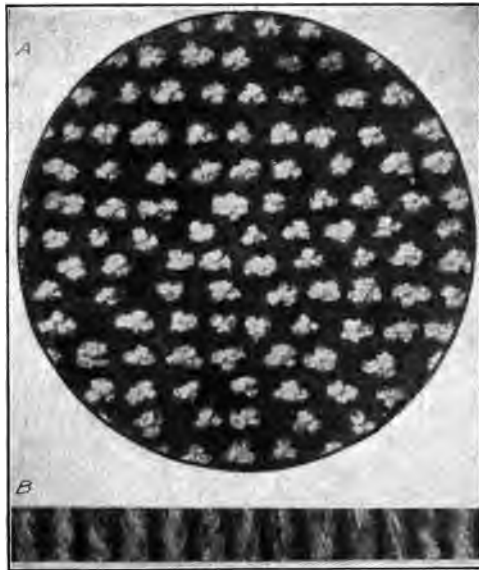

FIG. 55.—Microscopic section of Willard threaded rubber separator.

sulphuric acid ( $H_2SO_4$ ) and distilled water, the proportion being about two parts of acid to five parts of water by volume. The proportion of water and acid should be such that the density of the solution will have a specific gravity of 1.300 at  $70^\circ F$ .

*Specific Gravity.*—By specific gravity is meant the ratio of the weight of any substance compared with the weight of an equal volume of pure water at normal temperature and pressure. Pure water is considered to have a specific gravity of 1, usually written 1.000 and spoken of as *ten hundred*. One pound of water has a volume of approximately one pint. An equal volume of chemically pure sulphuric acid weighs 1.835 lb. It, therefore, has a specific gravity of 1.835 and is spoken of as *eighteen thirty-five*.



In the cells, the electrolyte should cover the tops of the plates from  $\frac{1}{4}$  in. to  $\frac{1}{2}$  in. at all times to prevent injury to the plates and separators.

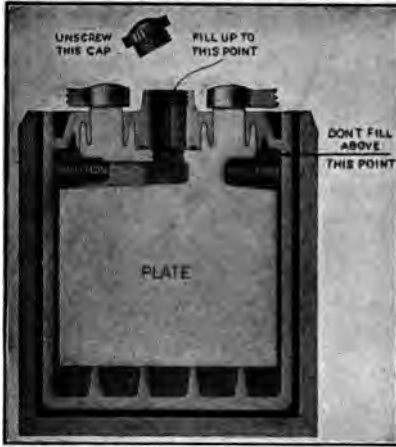

FIG. 56.—Section of storage cell showing proper level of electrolyte.

The proper level of the solution is shown in Fig. 56.

**30. The Hydrometer.**—A convenient way of testing the specific gravity of the electrolyte is by the hydrometer syringe as shown in Fig. 57A. This instrument consists of a large glass tube syringe within which is a small elongated glass hydrometer float with a vertical cylinder graduated from 1.100 to 1.300. The rubber bulb at the top is used to draw the liquid into the instrument. Normally, the hydrometer rests on the bottom of the tube but, as soon as a liquid with a specific gravity greater than 1.100 is drawn into the syringe, the hydrometer floats

at a depth according to the specific gravity of the liquid. The graduation on the scale in line with the surface of the electrolyte, Fig. 57B, is

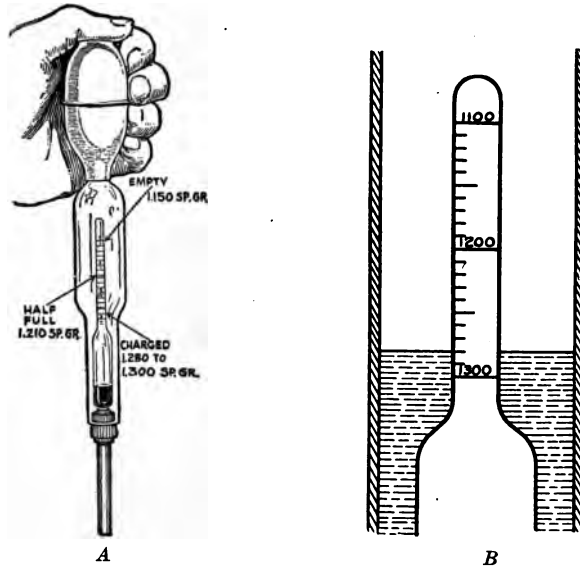

FIG. 57.—The syringe hydrometer.

the reading of the specific gravity of the solution. For convenience, its reading is spoken of as being 1150, 1200, 1280, 1300, etc., instead of 1.15, 1.2, 1.28, and 1.3 which is of course correct. The reading on the scale of

Fig. 57B is 1.280 or twelve-eighty. The hydrometer syringe is also used for adding water to the cells.

**31. Action of the Lead Storage Cell on Discharge.**—When the cell is fully charged, the electrolyte has a density, or specific gravity, of 1.275 to 1.300; the active material on the positive plates being peroxide of lead and on the negative plates pure spongy metallic lead. The voltage between the positive and negative groups is from 2.1 to 2.2 volts. Consequently, if the cell terminals are connected through an electric circuit, such as the ignition system, lighting system, or starting motor, current will flow due to this voltage. As the cell discharges, chemical action takes place between the sulphuric acid in the electrolyte and the lead in the plates, changing the lead peroxide of the positive plates and the pure spongy metallic lead of the negative plates into sulphate of lead. This lead sulphate is formed in the same way that copper sulphate is formed when sulphuric acid is dropped on a copper wire terminal and in the same way that iron sulphate is formed when sulphuric acid is dropped on the iron work of the car. In cases of this kind, it will always be noticed that the amount of sulphate formed is out of all proportion to the quantity of metal eaten away. In the same manner, when the sulphuric acid of the electrolyte combines with the lead in the plates to form lead sulphate, the volume is increased so as to fill completely the pores of the active material when the cell is completely discharged. This makes it difficult for the charging current to reach all parts of the active material, and accounts for the manufacturer's instructions never to discharge the battery below a certain point.

As the discharge progresses, the electrolyte becomes weaker, due to the amount of acid absorbed by the active material of the plate in the formation of lead sulphate, which, as previously explained, is a compound of sulphuric acid and lead. This lead sulphate continues to increase in bulk, filling the pores of the plates eventually to such an extent that the free circulation of the acid is retarded. Since the acid cannot reach the active material of the plates fast enough to maintain the normal action, the battery becomes less active. This is indicated, if tested at intervals by a low reading voltmeter, by a rapid falling off in the voltage. Starting at slightly over 2 volts per cell (the battery being fully charged), this voltage is maintained at normal discharge rates with but a slight drop until the lead sulphate begins to fill the plate. When this occurs, the voltage gradually drops to 1.8 volts per cell, and from this point on drops very rapidly. A voltage of 1.7 per cell indicates practically complete discharge; also, that the plates of the cell are filled with lead sulphate, and that the battery should be placed on charge immediately.

During the normal discharge, the amount of acid used from the electrolyte will cause the gravity of the solution to drop from 100 to 150 points, so that if the hydrometer shows a reading of 1.280, when the cell

is fully charged, it will indicate but 1.130 to 1.180 when it is exhausted or completely discharged. The electrolyte is then very weak; in fact, it is little more than pure water, since practically all of the available acid has been combined with the active material of the plates. Toward the end of the discharge, the electrolyte becomes so weak that it is no longer capable of producing current at a rate sufficient for any practical purpose.

**32. Action of the Lead Storage Cell on Charge.**—The action of the cell on charge consists of a reversal of the process which takes place when the cell discharges. This is accomplished by sending a direct current through the cell in a charging direction which is opposite in direction to the current flow when the cell discharges; namely, *in* at the positive terminal and *out* at the negative terminal. When the charging current is sent through the cell, the action is as follows: The sulphuric acid, which was absorbed by the plates on discharge, forming lead sulphate, is forced out of the plates back into the electrolyte thus raising the specific gravity. At the same time the lead sulphate on both plates (caused by the sulphur in the acid combining with the lead) is converted back to peroxide of lead in the positive plates, and into spongy metallic lead in the negative plates. When practically all of the acid has been transferred from the plates to the electrolyte and the sulphate converted back into its original form, the cell is said to be fully charged and should then show a specific gravity of 1.275 to 1.300 and a voltage of about 2.2 volts on open circuit.

When the cells are completely charged, the charging current can do no more useful work. Its only effect then will be to convert particles of water in the electrolyte to hydrogen and oxygen gas which will bubble up violently and thereby indicate that the battery is nearing a full state of charge. On the other hand, if the elements of the cells do not receive sufficient charge, the sulphate may harden to such an extent as to be very difficult to remove from the plates. Furthermore, if the battery is allowed to remain in an uncharged condition, a denser and harder sulphate, which is even more difficult to remove, will form on the plates. This hardening of the sulphate, commonly known as sulphation, takes place to some extent even when the battery is considered fully charged. It is advisable, therefore, to charge the battery immediately after a discharge and about once a month when out of service, even though it is considered fully charged.

**33. Heat Formed on Charge and Discharge.**—When the cell is charged or discharged, the chemical reactions due to the passage of the current through the electrolyte cause heat to be generated. This heat does not become injurious until the temperature rises to about 105°F., and it may rise to 110°F. or even higher for a brief period of time without injury to the plates. It is not considered advisable, however, to charge a battery for any length of time after the temperature has risen to 105°F.

The battery should either be taken off charge and allowed to cool or the charging rate should be reduced.

**34. Evaporation of Water.**—The water in the electrolyte evaporates slowly due to the heat formed on charge and discharge and also due to the gassing on overcharge. The sulphuric acid, however, does not evaporate and, consequently, the solution becomes denser. This loss of water due to evaporation must, therefore, be made up by adding only pure water. The amount of evaporation depends on the temperature and on the amount of work done by the battery, and is a varying quantity. A safe rule to follow is to replace the water every week in summer and every two weeks in winter, during ordinary use of the car. If the car is out of service, water should be added once every two weeks in summer and once a month in winter before it is given a refreshing charge. During cross-country touring it is good practice to add distilled water every 200 miles of travel, or once a day. The hydrometer syringe may be used for adding the water. Enough water should be added to keep the level of the electrolyte at all times up to the bottom of the inside cover, or  $\frac{3}{8}$  in. to  $\frac{1}{2}$  in. above the tops of the plates as shown in Fig. 56. The cells should never be filled above this level. The electrolyte expands when charging, due both to the increase in temperature and to the gas bubbles which rise from the plates; therefore, space must be allowed for expansion. The battery if filled too full will run over, resulting not only in loss of electrolyte, but in the eating away of the battery box and serious corrosion of the battery terminals and connectors. Discharge circuits may also result from the film of electrolyte remaining on the top of the battery.

**35. Necessity of Adding Pure Water.**—Only absolutely pure water, such as distilled water, should be used in filling the battery. Distilled water is obtained by boiling water, catching the steam that comes off, and condensing it into a liquid. Distilled water can usually be obtained at any drug store or garage and must be kept in an acid-proof vessel. A common way of storing it is in a glass bottle or jug. Water which has merely been boiled should not be used. If distilled water is hard to obtain, melted artificial ice, or filtered rain water which has not come into contact with iron pipes or tin roofs, may be used. A common way of collecting the latter is to catch the rain directly in an earthenware jar set out after it has been raining for about 5 or 10 minutes. This is to insure that there are no impurities in the form of gases and small solid particles taken into the water on its journey from the clouds. The use of spring, river, hydrant, or well water should be avoided as these are liable to contain iron or other substances detrimental to the life of the battery.

**36. Storage Battery Testing.**—Due to the action which takes place in the battery cells upon discharge (the acid of the electrolyte combining with the active material in the plates forming lead sulphate), the specific gravity change of the electrolyte will be directly in proportion to the

state of charge of the battery. Thus by merely testing the gravity of the electrolyte with a hydrometer the exact state of charge of the battery can at once be determined, providing there has been no loss of electrolyte through spilling, and that no acid or other liquid has been added by persons not familiar with battery principles in an attempt either to charge the battery or to keep it from freezing. If it is known that the battery has been so treated, the voltage of each cell should be taken with a low-reading voltmeter to check the hydrometer readings. When fully charged, each cell should show a specific gravity of 1.280 to 1.300 and about 2.2 volts per cell. The following table gives the state of charge, also the freezing temperature of the storage battery at different specific gravities. It will

Specific Gravity	Approximate Voltage Per Cell	Condition of Battery	Freezing Point in Degrees Fahrenheit
1.275 to 1.300	2.2	Fully charged	90 degrees below zero
1.260	2.1	$\frac{3}{4}$ charged	60 degrees below zero
1.210	2.0	$\frac{1}{2}$ charged	20 degrees below zero
1.160	1.9	$\frac{1}{4}$ charged	Zero
1.120 or below	1.8 or less	Completely discharged	20 degrees above zero

be noted that the freezing point of electrolyte depends upon its specific gravity and the condition of battery charge. Therefore, to prevent a battery from freezing, it should be kept in a fully charged condition.

**37. Variations in Cell Readings.**—If the specific gravity in any cell tests more than 25 points lower than the other cells in a battery, it is an indication that this cell is out of order. One reading to determine the specific gravity of a cell is not sufficient. Several readings should be taken and the average determined. Variations in the readings of different cells may be due to short circuits inside one or more of the cells; putting too much water in the cell, causing the electrolyte to overflow; or to loss of electrolyte due to a cracked or leaky jar.

Low specific gravity in one or more cells can very often be brought up by driving the car (using starter and lights sparingly), or charging by means of the generator with the engine running idle, in which case readings ought to be taken at frequent intervals. If the specific gravity in any cell does not come up to at least 1.260 after the other cell readings indicate that the battery is fully charged, it is an indication that the low cell is in need of internal adjustment. This can only be done by an experienced battery repairman.

Most battery troubles can be traced to the electrolyte becoming too low in the cells. The effect of this is to weaken the battery, thus permitting it to be more easily discharged, and frequently causing harmful sulphation of the plates and injury to the separators. This may also allow the plates to come together, causing internal short circuits. It is

very important, therefore, that pure distilled water be added regularly to all cells in order to keep the electrolyte up to the level specified by the manufacturer.

If the battery does not regain its full power and efficiency within one or two days after continuous charging on the car as explained above, it is an indication that the battery is badly sulphated, or has some other internal trouble. In such condition the battery should receive immediate attention from a competent battery man, otherwise it may be entirely ruined. A frequent cause for the electrolyte being low in one or more cells is the presence of a cracked or leaky jar. If one cell needs more frequent addition of water than the other cells, it is a good indication that the jar leaks. This condition calls for immediate action, as the trouble can very easily be corrected if the battery is taken to a service station at once and a new jar installed. If the cracked or leaky jar is not immediately replaced, the cell will be totally ruined and very likely the entire battery seriously damaged, if left in service. Jars are frequently broken due to the battery hold-down bolts or clips coming loose, allowing the battery to jolt around; or to freezing of the electrolyte in cold weather.

### 38. Variation in Hydrometer Readings Due to Temperature Changes.

All the definite figures given in hydrometer readings are based on the normal temperature of 70°F. for the electrolyte. This refers to the temperature of the liquid itself, and not to the temperature of the surrounding atmosphere. The weather might be freezing cold and yet the temperature of the liquid solution in the battery might be normal or above, either from the heat of the engine or because the battery was being vigorously charged.

The temperature of a battery may be readily measured with a dairy thermometer or a special inexpensive battery thermometer intended for this purpose. The thermometer is inserted through the vent plug-hole in the liquid in the same way as a hydrometer. The rule in making temperature correction is that for every 3° above 70°F., 0.001 be added to the hydrometer reading; and for every 3° below 70°F., 0.001 be subtracted from the observed reading. For example: If the temperature at the end of charge is 120°F. and the observed gravity reading is 1.260, the corrected reading is determined as follows:

$$\begin{aligned} 120^\circ - 70^\circ &= 50^\circ \\ 50^\circ \div 3^\circ &= 17^\circ (\text{approximately}) \\ 17^\circ \times 0.001 &= 0.017^\circ \end{aligned}$$

$$\text{Corrected reading: } 1.260^\circ + 0.017^\circ = 1.277^\circ.$$

Again, if the reading at 0°F. is 1.210, then

$$\begin{aligned} 70^\circ - 0^\circ &= 70^\circ \\ 70^\circ \div 3^\circ &= 23^\circ (\text{approximately}) \\ 23^\circ \times 0.001 &= 0.023^\circ \end{aligned}$$

$$\text{Corrected reading: } 1.210^\circ - 0.023^\circ = 1.187^\circ$$

From the above it can be seen that the temperature must be taken into consideration, otherwise the hydrometer reading will be misleading. It is usually unnecessary to make allowance for temperature variations, but it is well to bear them in mind, particularly in the case of a battery which has been giving trouble.

Another thing to remember in this connection is that in hot weather, if the temperature of the liquid is more than 20° in excess of the temperature of its immediate surroundings, the battery is possibly being overcharged or being charged at too high a rate, or is in a bad condition. This, however, cannot be given as a positive rule. In theory, the temperature of the liquid in a battery should never exceed 105°F. as high temperatures have an injurious effect and tend to shorten the life of the battery; but as long as batteries are carried in locations subjected to engine heat, and used on automobiles in hot climates, ideal conditions do not exist and the battery must get along as well as it can.

**39. Capacity of a Storage Battery.**—The amount of current that a cell will produce on discharge is known as its capacity, and is measured in *ampere-hours*. It is impossible for a cell to discharge as much current as was required to charge it, the efficiency of the average cell of modern type when in good condition being 80 to 85 per cent., or possibly a little higher when at its best, which is after five or six discharges. In other words, if 100 ampere-hours are required to charge a battery, only 80 to 85 ampere-hours can be discharged from it. This ampere-hour capacity of the cell depends upon the area of the plates and the number of plates in the cell.

The capacity of the cell as expressed in ampere-hours is based on its normal discharge rate. A 100 ampere-hour battery will produce current at the rate of one ampere for practically one hundred hours or more, two amperes for fifty hours, or five amperes for twenty hours, but as the discharge rate is increased beyond a certain point, the capacity of the battery falls off; consequently, it would not produce 50 amperes of current for 2 hours. This is because of the fact that a heavy discharge produces lead sulphate so rapidly and in such large quantities that it fills the pores quickly and prevents further access of the acid to the active material. Although the battery will not produce 50 amperes of current for two hours on continuous discharge, it will be capable of a discharge as great or considerably greater than this if allowed periods of rest between. On open circuit, the storage battery recuperates very rapidly. It is for this reason that when trying to start the engine the starting switch should never be kept closed for more than a few seconds at a time. Ten trials of ten seconds each with a half minute interval between them cause the battery to become much less exhausted than if the engine is turned over steadily for a minute and forty seconds.

**40. Battery Charging.**—When batteries are charged from an outside source, only *direct current* should be used. It is not possible to charge batteries from an alternating current supply without an apparatus, either a *motor-generator* or some other form of *rectifier*, to convert the alternating current into direct current.

In charging, the positive wire of the charging circuit must always be connected to the positive (+) terminal of the battery. If this is reversed, serious injury may result to the battery. The charging wires may be tested for polarity either by using a voltmeter or by immersing the ends of the wires in a glass of water to which a few drops of acid or a little salt have been added, when excessive bubbles will form on the negative wire.

In charging from a 110-volt direct-current supply it is necessary to introduce either a rheostat (an adjustable resistance unit), Fig. 58, or a bank of lamps, Fig. 59, in series with the battery in order to regulate the flow of charging current. When using a lamp bank to regulate the rate

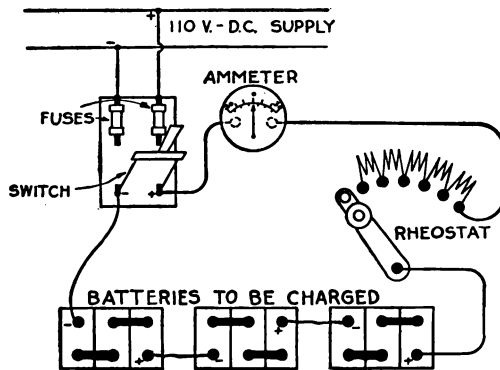

FIG. 58.—Charging batteries from 110-volt D.C. supply, using rheostat for resistance.

of current, as in Fig. 59, 110-volt 32 candlepower carbon filament lamps should be used. These lamps should be connected in parallel with each other, and the combination connected in series with the battery. With this arrangement, each lamp will permit about one ampere of charging current to pass through the battery so that the number of lamps in use will be approximately equal to the number of amperes of current to be used in charging. The charging rate may be adjusted by turning the lights off or on, or by moving the rheostat handle until the ammeter shows the proper reading.

Where more than one battery is to be charged at a time, the batteries should be connected in series; that is, the positive terminal of one battery should be connected to the negative terminal of the adjoining battery. Rubber covered copper wire (No. 14 or larger) cut in lengths of about 18 in. should be used to connect batteries in this manner. The wire is connected to the terminals, either by attaching clips to the ends of the



wires, or by twisting the wire around the terminals. Care should be taken to see that a good contact is made without damaging the terminals.

The total voltage of a combination of batteries is the sum of all the cells in the circuit multiplied by the voltage of each cell (2 volts). In charging batteries, each cell requires 2.5 volts; therefore, care should be taken to see that the total voltage required for charging all the cells does not equal or exceed the operating voltage of the generator. Should the total voltage of the cells, while on charge, equal the voltage of the generator, no current will pass through the battery. Should the total voltage of the cells exceed the voltage of the generator, the batteries will discharge themselves through the generator. When charging several batteries in series, care should be taken to see that the charging rate does not exceed the maximum rate of the battery requiring the lowest charging current.

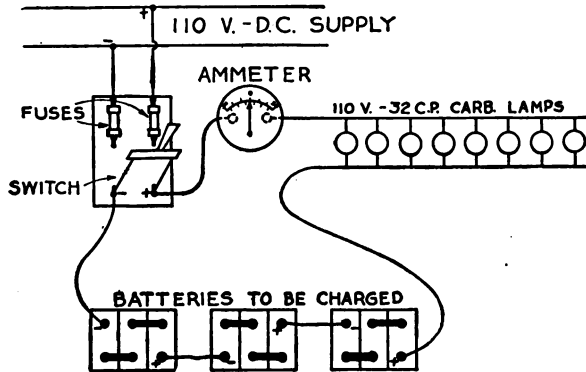

Fig. 59.—Charging batteries from 110-volt D.C. supply, using lamps for resistance.

The charging rate of most batteries is marked on the name plate; in fact, two rates, *start* and *finish*, are usually given. The reason for this is that it is much better for the battery if the charging rate is reduced when approaching a full state of charge, to avoid excessive heating and evaporation of the electrolyte. If the charging rates are not marked on the battery, a safe charging rate at the start would be about 10 per cent. of the rated ampere-hour capacity, and 5 per cent. of this rating to finish. In the case of an 80 ampere-hour battery, the charging rate at the start should be 10 per cent. of 80 or 8 amp. and at the finish 5 per cent. of 80 or 4 amp. If the ampere-hour capacity is not known, the charging rate at the start may be 8 to 10 amp., but should be reduced to a lower rate if any of the cells show signs of excessive heating or gassing.

**41. Detailed Instructions for Battery Charging.**—Before placing the battery on charge, or removing the vent plugs (or caps), the entire top of the battery should be thoroughly cleaned off to prevent any

dirt or impurities from falling into the cells. If any of the cells or outside battery parts are corroded, the corrosion should be cleaned off with a solution of ordinary washing soda and water, applied with a clean cloth or sponge. The vent plugs (or caps) should then be removed and not replaced until the battery is removed from the charging circuit, unless a special type of filler tube is used which requires the plug to remain in place while the battery is charging. In this case, the plug is removed only when it is necessary to take a hydrometer reading or to add distilled water. Distilled water should be added to all the cells in sufficient quantities to bring the electrolyte up to the proper level, which in most batteries is  $\frac{1}{2}$  in. above the top of the plates.

The battery is placed on charge at the *start* rate specified on the name plate and the voltage of each cell tested immediately. The voltage and hydrometer readings of each cell should be made every hour. The charge at the *start* rate should continue until one or more of the cells are *gassing* vigorously and the voltage of each cell reads 2.5 or higher during charge. The charging rate should then be reduced to the *finish* rate and charging continued at this rate until the battery is fully charged.

A battery is fully charged when, with the current flowing at the *finish* rate, all cells are *gassing* vigorously; the voltage and specific gravity of each cell have stopped rising and have been constant for one hour; the voltage will read 2.4 or higher per cell while charging, but will drop to 2.25 immediately upon removing the battery from charge, after which it will gradually drop to about 2.1 volts per cell; and the specific gravity of each cell tests between 1.275 and 1.300.

Although it is always advisable to use a voltmeter in battery charging it is not absolutely essential. When a voltmeter is not used, the *start* rate should be continued until the battery is *gassing* vigorously. The rate should then be reduced to the *finish* rate and charging continued until the specific gravity of all the cells has stopped rising and remains constant for one hour. If the specific gravity rises above 1.300, while the battery is on charge, part of the electrolyte should be drawn from the cells and enough distilled water added to reduce the specific gravity to 1.285. If, on the other hand, the specific gravity will not come up to 1.275 by continuous charging, it indicates that there is insufficient acid in the electrolyte. The specific gravity should be corrected by removing some of the electrolyte from the defective cell and replacing it with a like amount of electrolyte of 1.350 to 1.400 sp. gr. Pure acid should never be added to a battery as it will gas and heat violently and will damage the plates and separators. Figure 60 shows the effect on wood separators by filling the cell with too strong an acid solution. After the specific gravity has been adjusted, the battery should remain on charge for at least one hour. The voltage at the completion

of the charge should be about 2.5 volts for each cell, but this will immediately drop to approximately 2.2 volts per cell making the voltage of a fully charged three-cell battery about 6.6 volts. The voltage, however, will vary slightly with the temperature.

*Caution.*—Care should be taken to keep open flames away from a battery which is or has been charging or discharging. The gas which accumulates in the cells, due to the chemical action, is combustible and may cause sufficient explosion to wreck the battery and injure the operator.

After the battery has been removed from the charging line, the vent caps should be screwed tightly into place and the battery top and connecting terminals cleaned with water. To prevent corrosion of the



FIG. 60.—Effect of strong electrolyte on wood separator.

battery terminals by the acid they should be greased with a light coat of vaseline or soft grease.

**42. Sulphation.**—When a storage battery is discharging, the plates are acted upon by the sulphuric acid in the electrolyte, converting the lead peroxide of the positive plate and the pure sponge lead of the negative plate into a lead sulphate, which is converted back into its original form when the battery is recharged. When the plates are permitted to remain in a discharged condition, the lead sulphate grows into a hard, white, crystalline formation, which closes up the pores, destroying the active area of the plates. This formation is known as *sulphation*. Figure 61 shows a positive group of a battery with wood separators that has been operated in a partially discharged condition for some length of time. The white area on the plate indicates the sulphation.

Sulphation is also caused by low electrolyte or because the cell has not been filled with water. If water is not added at regular intervals to replace loss through evaporation, the electrolyte level will soon fall below the plate tops, causing that portion of the plates which is exposed to the air to sulphate rapidly. Figure 62 shows a sulphated condition of plates, after a few months' use (or rather misuse), produced by lack of water and by allowing the solution to become low and not cover the plates. A hard white sulphate has formed on the top half of the plates. It is difficult and sometimes impossible to recharge and bring back to normal condition a plate that has dried out and has become hard. The concentrated condition of the electrolyte (only the water evaporates) is also injurious to the lower half of the plates and

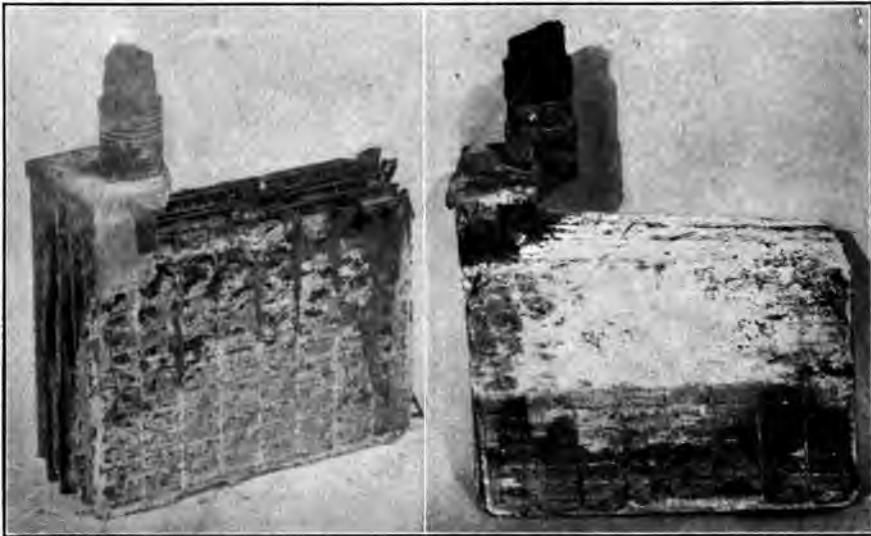

FIG. 61.—Sulphation of battery plates due to undercharging.

FIG. 62.—Sulphation due to underfilling of battery.

separators. Sulphate is a non-conductor of electricity; therefore, it is quite destructive to the activity of the plates and reduces materially the ampere-hour capacity of the battery. For example, in a 100 ampere-hour battery in which one half of the plate area is sealed up by the sulphation, the capacity will be reduced approximately 50 per cent. and the battery capable of no more work than a battery rated at 50 ampere-hour capacity. The only way sulphation can be removed, if it is not too bad, is by prolonged charging at a very slow rate, usually the finish rate for the battery. It may require charging for several days to restore it to a fully charged condition.

*In order to prevent sulphation, the battery should be kept charged and the plates well covered with electrolyte.*

**43. Effect of Overfilling.**—The effect of overfilling a battery is well illustrated by Fig. 63. The battery should be filled with water up to the bottom of the cover tube, or  $\frac{3}{8}$  in. to  $\frac{1}{2}$  in. above the top of the plates. If it is filled above this point, it will run over upon charging, due to the lack of space for expansion. This will result in a loss of the electrolyte and an eating away of the battery box as indi-



FIG. 63.—Effect of over-filling the battery cells.

cated. The electrolyte may also get into the metal case and eat out the bottom.

**44. Corroded Terminals.**—Frequently, the terminals and connectors will be found covered with a greenish deposit. This is a corrosion due to the acid fumes which are constantly passing off from the cells



FIG. 64.—Effect of corrosion on battery cable terminals.

and attacking the metal connectors. Figure 64 shows a cable terminal badly corroded by the splashing or spraying of electrolyte on the bare cable wires where insulation has been stripped off.

The eating action may be stopped and all corrosion removed by soaking the parts in a solution of bicarbonate of soda (common baking soda) or ammonia and brushing them with a stiff brush, after which they

should be wiped dry. Further corrosion will be prevented by covering the parts with a light coat of vaseline or cup grease.

**45. Disintegrated and Buckled Plates.**—Overheating of the plates, through excessive charging or discharging, causes them to warp or *buckle*. It also causes disintegration of the active material, especially in the positive plates. Figure 65 shows what continuous overcharging does to the positive plates. It softens up the material and causes the battery to give unusually high capacity for a short time. The material then begins to disintegrate and fall out. The effect is about the same as freezing. In order to determine which condition has existed it should

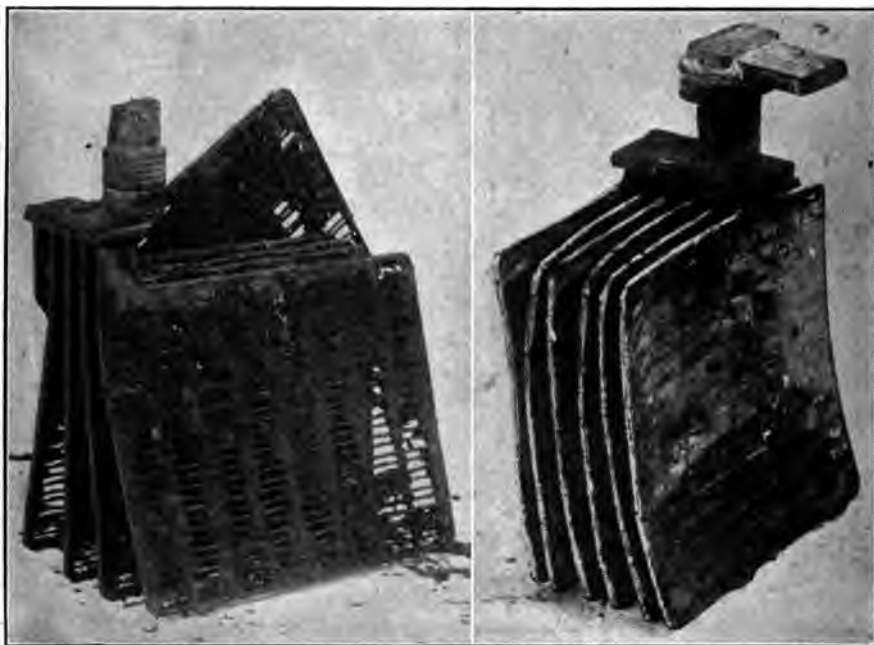

FIG. 65.—Effect on battery plates of continuous overheating.

FIG. 66.—Buckled battery plates.

be remembered that overheating usually blackens and softens the wood separators.

A plate is especially liable to buckle, when in a sulphated condition, if discharged or charged at a high rate. The sulphated portion of the plate does not expand at the same rate as the active area, thus causing unequal expansion and a warping, sometimes cracking, of the grid. A group which has been allowed to stand discharged at a low point for some time, then charged at a high rate to restore its energy, is shown in Fig. 66. On account of the hardness of the plates and the extra resistance of the sulphate formed during the excessively low period of discharge the plates become very hot and being only slightly flexible or

elastic, warp or buckle when expanded by heat. Figure 66 shows the difference between a cell continuously overcharged and one which has been undercharged so that the sulphation has become hard. Buckling also causes a breaking down of the separators and often results in cracking the jar, as in Fig. 67, resulting in loss of the electrolyte.

To avoid overheating and buckling of the plates, the following precautions should be taken:

1. Sulphation should be prevented by keeping the battery charged and properly filled.
2. The generator should be adjusted to charge the battery at the proper rate.
3. The starting motor should not be operated excessively.
4. The car should not be propelled with the starter.



FIG. 67.—Cracked jar due to buckled plates.



FIG. 68.—A worn-out battery plate showing the active material fallen out and the grid exposed.

5. The battery temperature should be watched in hot weather, and when touring. If the top connectors feel warm to the hand, the headlights should be turned "ON" to cut down the battery charging rate.

**46. Sediment.**—When a battery is used, a deposit known as *sediment* collects in the bottom of the jars, due to the gradual wearing away of the active material in the plates. Figure 68 shows a worn-out plate from which practically all the active material has fallen. In time, this sediment may fill up the sediment or *mud* space, causing a short circuit at the bottom of the plates. In this event, the cell must be dismantled and the sediment removed. Broken down insulation due to high sediment or defective separators is indicated by the inability of a cell to hold a charge on open circuit. Other indications of broken down insulators are undue heating of the cells upon charging, little or no voltage or gravity rise

after a prolonged charge, and the impossibility of making the cells gas properly. Such a cell is considered *dead* and can be remedied only by dismantling and rebuilding the battery. This is a job which should be undertaken only by an experienced battery repairman as it involves lead burning usually with either a hydrogen or oxy-acetylene flame, an art requiring special lead burning equipment, and much practice.

**47. Care of Storage Batteries in Winter.**—It will be noted from the table on page 38 that the freezing point of electrolyte depends upon its specific gravity and the condition of battery charge. Therefore, to prevent a battery from freezing, it must be kept in a fully charged condition. The effects of freezing are clearly shown in Fig. 69 and Fig. 70.

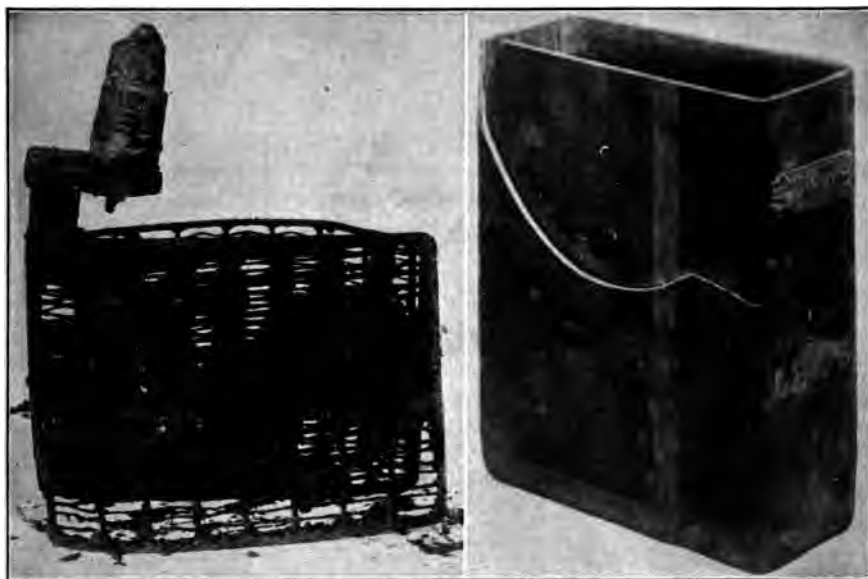

FIG. 69.—Effect of freezing on battery plates.

FIG. 70.—Cracked battery jar due to freezing.

If it becomes necessary to add water to the battery in cold weather, this should be done just before running the engine. In very cold weather, however, it is better to start the engine and have the battery charging before the water is added. This is done because water, being lighter than electrolyte, remains on the surface of the liquid in the cells until circulated and mixed by the charging current. If water is added, therefore, and the battery allowed to stand for a time without charging, there is a possibility of the water's freezing on the surface of the solution.

**48. Conditions Causing the Battery in the Electrical System to Run Down.**—It is impossible to include here all the conditions which may cause the battery in the electrical system to run down, since many of the causes may be due to faults in the starting and generating system. How-



ever, a few of the most important causes are given to assist in diagnosing battery trouble on the automobile.

A discharged or weak condition of the battery, which is indicated by feeble ignition, a loss in cranking power of the starter, dim lights, low specific gravity, etc. may be attributed to one of the following causes:

1. Generator either not charging the battery or charging at insufficient rate.
2. Battery plates not kept properly covered with electrolyte, causing sulphation of the plates.
3. Drain on battery due to excessive lamp load or too many electrical accessories not intended for the battery.
4. Engine not driven fast enough to charge at sufficient rate.
5. Too much night driving with full lamp load on.
6. Excessive use of the starting motor; starting switch sticking.
7. Electrical cut-out not operating properly.
8. Battery ignition switch left *on* with engine not running.
9. Cracked jar causing loss of electrolyte.
10. Broken down battery insulation due to high sediment or defective separators.
11. Loose connections on generator, cut-out, or battery.
12. Corroded battery terminals.
13. Overfilling, causing loss of electrolyte and short circuits.

## CHAPTER III

### THE JUMP-SPARK IGNITION SYSTEM

**49. Requirements of Automotive Engine Ignition.**—The internal combustion engines used for automobile, truck, tractor, motor boat, and airplane propulsion at the present time depend upon some form of electrical ignition for igniting the charge of fuel within the engine cylinder. This is accomplished by means of an electric spark produced inside the cylinder when the respective piston is nearing the end of its compression stroke.

The engines used on automobiles, trucks, tractors, and airplanes operate on the *four-stroke cycle* principle in which four strokes of the piston are required to complete the four events of the engine cycle: namely, the *suction stroke* in which a charge of fresh gas is drawn into the cylinder; the *compression stroke* in which the charge of gas is compressed into the upper end of the cylinder; the *power* or *working stroke* at the beginning of which the gas is ignited; and the *exhaust stroke* during which the burned gas is pushed out of the cylinder. These four strokes are completed in two revolutions of the flywheel. Consequently, one ignition spark is required for each cylinder every two revolutions of the engine. When it is considered that many of the modern four-, six-, eight-, and twelve-cylinder engines run up to 3,000 and 4,000 revolutions per minute, requiring of a single ignition system as many as 400 sparks per second, it will be realized that the proper action of the ignition system in supplying a spark in each cylinder at the proper time is of the utmost importance.

Another type of internal combustion engine used to some extent on motor boats and for small stationary installations operates on the *two-stroke cycle* principle, in which but two strokes of the piston are needed to complete the events of the engine cycle. In this type of engine the suction stroke and the exhaust stroke of the four-stroke cycle engine are absent, the crank case of the engine being used as a pump to force the fresh gas into the working end of the cylinder. The entering charge of gas blows the burned gas out of the cylinder through a port in the cylinder wall which is uncovered by the piston at the lower end of its stroke. This engine requires one spark for each cylinder every revolution of the crankshaft, but due to the fact that the speed of the two-stroke cycle engine is limited to about 1,000 revolutions per minute, the total number of ignition sparks required per second from the ignition system never reaches the maximum mentioned for the four-stroke cycle engine.

**50. Make-and-break and Jump-spark Ignition.**—Two methods of electrical ignition have been used; namely, the *make-and-break* and the *jump-spark*. The latter method, however, is the only one satisfactory for high-speed service, the make-and-break system being used chiefly on low-speed engines with a high compression of 150 lb. per sq. in. or over.

In the *make-and-break* method of ignition, an electric current of low voltage, furnished either by a battery or by a magneto, is made and broken by a contact mechanism known as an *igniter*, Fig. 71, the contact points of which extend into the combustion chamber of the engine cylinder. The igniter mechanism is operated by a push rod which in turn is operated by a cam driven by the crankshaft at one-half engine speed. This mechanism is timed so as to effect ignition when the fuel charge is near maximum compression or when the piston is approximately on head end dead center position. The spark for ignition occurs at the instant the contacts open, and is caused by the sudden stoppage of the electric current in combination with the action of a low-voltage coil connected in the circuit.

In the *jump-spark* ignition system, current is derived either from a battery or from a magneto, but it is first transformed from low voltage to high voltage by means of an induction coil, whereupon the high-voltage current is made to jump the points of a *spark plug* inside the cylinder. The spark thus created sets fire to the combustible gases.

For automotive engine ignition the *make-and-break* method is no longer used, it having given way to the jump-spark method on account of the greater simplicity and many advantages of the latter. However, owing to the similarity in the action of the ignition coils used in both systems, the operation of the make-and-break coil should be clearly understood.

**51. The Low-tension Coil for Make-and-break Ignition.**—The coil used for make-and-break ignition is very simple in construction in that it consists of a single winding of insulated copper wire wound on a soft iron core as shown in Fig. 71. The core is usually made of a bundle of soft iron wire so that it will magnetize and demagnetize rapidly. Such a coil is usually termed a *kick* coil for the reason that, if a current through the coil is suddenly interrupted by breaking the circuit, a *flashy spark* of considerable intensity or "kick" will occur at the point of current interruption. The spark thus produced occurs between the igniter points inside the cylinder and is made use of in igniting the fuel charge.

The large flashy spark which occurs at the point of current interruption is due to the induction of a voltage and a current in the winding of the coil by the collapsing lines of force when the circuit is broken. From a study of Fig. 71 it will be seen that, upon the demagnetizing of the core, the magnetic lines of force will move rapidly toward the core and cut

each turn of wire much the same as in Fig. 24. This cutting of the wire by the lines of force will set up a whirl of magnetic lines around each turn of wire and induce a voltage in the coil in the same direction as the original current from the batteries. This induced or kick voltage of the coil is in series with the battery voltage and often reaches a momentary pressure of 200 to 300 volts, depending on the design and the size of the coil. Such a voltage is sufficient to break down for an instant the resistance of the air gap between the igniter points, when the circuit is broken, thus permitting the induced current to flow across this gap and produce a very hot, yellow, flashy spark.

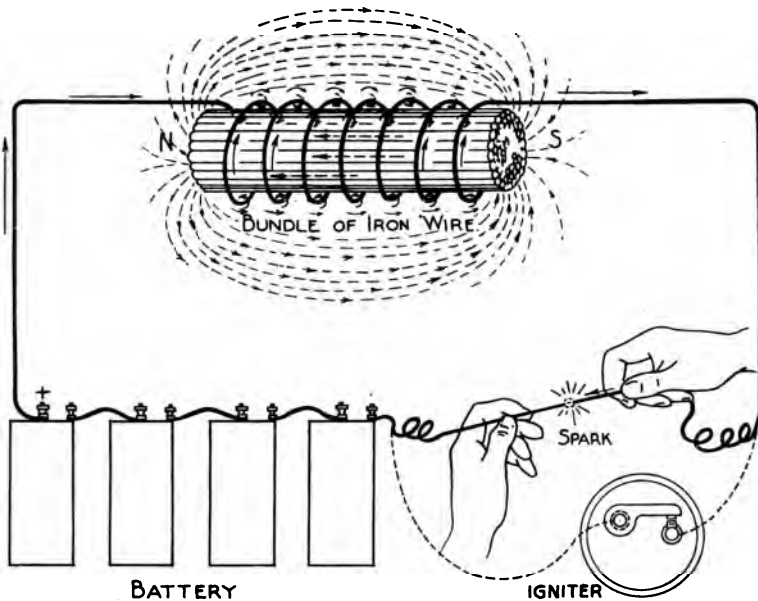

FIG. 71:—Principle of the low-tension coil.

The action of a *kick* coil may be compared to the water hammer in a water pipe. If the valve is closed suddenly, when the water is flowing, the momentum of the water in motion will produce a terrific blow on the valve, known as water hammer. The instantaneous pressure produced by the water hammer may be several times that of the ordinary pressure of the water which set up the motion when the valve was open.

**52. The Induction Coil.**—When the current for automobile ignition is derived from the *dry battery, storage battery, low-tension magneto, or generator*, the voltage usually ranges from 6 to 12 volts. This voltage is too low to force a spark to jump the gap between the spark plug points inside of the engine cylinder; consequently, the low-voltage current must first be transformed to a current of high voltage by a special transformer known as an *induction coil*. Induction coils may be of either the vibrat-

ing or non-vibrating type, but in either case the general construction and principle of operation are the same. The chief difference is that the vibrating type induction coil operates with a *timer* and gives a shower of sparks at the plug, while the non-vibrating type of coil operates with a *breaker* and gives a single spark at the plug. The non-vibrating coil is the more popular for automobile ignition. Its application to a jump-spark ignition system is illustrated in Fig. 72.

The induction coil consists essentially of a *primary* and a *secondary* winding, both wound on a core of soft iron. This core usually consists of a bundle of soft iron wires, the core being about  $\frac{1}{2}$  in. to  $\frac{3}{4}$  in. in diameter and 5 in. to 6 in. long. The wires are annealed to make them as soft as possible so that the core will magnetize and demagnetize rapidly.

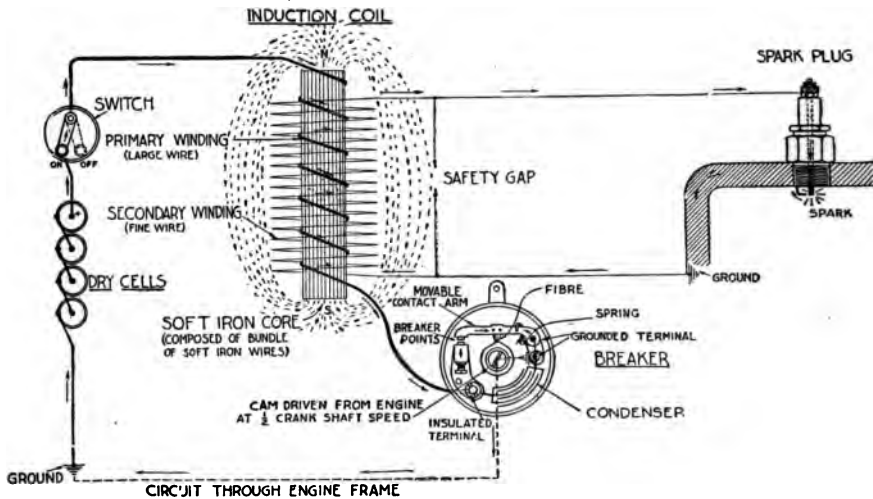

FIG. 72.—Jump-spark ignition with breaker and non-vibrating coil.

The *primary* winding which is connected to the source of current supply consists usually of several layers of insulated copper wire, ranging in size from No. 16 to No. 20 B & S gage. The wire is wound around the core so as to make it an electromagnet. The insulation of the wire usually consists of layers of cotton fiber, though in some cases an enamel insulation is used.

The *secondary*, or high-tension winding, to which the spark plug is connected, is wound outside of the primary coil and is made up of several thousand turns of enameled or silk covered copper wire, usually about No. 36 B & S gage. This winding is sometimes made up of many layers, each layer running the entire length of the coil, the layers being insulated from each other by paraffin wax paper. In another type of construction, the winding is made up of several narrow spools or "pancakes" assembled over the primary coil with suitable insulation between. The adjacent

ends of these pancake coils are connected so that their windings are in series.

The reason for this construction is as follows: The secondary winding of an induction coil used for gas-engine ignition produces, at times, a pressure of 10,000 to 20,000 volts. This means that the quality of the insulation and construction must be very high to prevent this induced current from escaping at some other point than at the spark-plug gap. The normal voltage necessary to jump the spark-plug points under compression and with the points properly adjusted is usually from 5,000 to 6,000 volts. Each turn of the winding develops its share of the voltage of the whole coil. In coils where the winding is made in long layers, the full voltage developed exists between the inner and outer layers. One can see, then, that there is a chance for the spark to leap between layers, which, of course, must be prevented by high-quality insulation. It is a common practice to run a layer of thin waxed paper between the layers of wire and to impregnate the whole winding with wax. In this way the coil is not affected by dampness and there is less chance for the winding to break down due to defective insulation. By break down of the secondary winding is meant a flow of the current between layers of the winding, causing an arc within the coil instead of at the desired point where the spark is wanted. In pancake windings, the terminals of the secondary coil are separated the full length of the coil and the voltage difference between the successive reels or pancakes is only a fraction of the total voltage.

The secondary winding of a coil should also be well insulated from the primary winding. For insulating purposes a material having a high *dielectric* or insulating strength should be used. The best dielectric materials are glass, mica, rubber, paraffined paper, "empire cloth," porcelain, etc. For this particular purpose, empire cloth is particularly suited, having a high dielectric strength and being flexible and comparatively thin.

**53. Coil Impregnation.**—Induction coils are sometimes treated by a special process in which an attempt is made to exclude all moisture. If any moisture remains, the coils will always cause more or less trouble, due to short circuits and consequent breaking down of the insulation. The usual practice consists of placing the coils in a large steam jacketed tank, sealed absolutely air-tight, and heated for 6 hours to a temperature of 250°F. This temperature, being above the boiling point of water, drives the moisture out of the windings. At the end of this period a vacuum is created in the tank, drawing out all the moisture, after which a molten dielectric solution such as wax or paraffin is allowed to flow in. A pressure of 125 lb. to the sq. in. is then maintained for about 3 hours in the tank containing the coils. This pressure forces the dielectric or insulating compound into every pore of the paper and silk

insulation, replacing the moisture that has been removed by the high temperature and vacuum process.

**54. Operation of the Simple Jump-spark Ignition System.**—In Fig. 72 is shown a circuit diagram of a simple ignition system for a single cylinder four-cycle engine. The induction coil is of the *non-vibrating* type operating with a breaker for making and breaking the primary current. It will be noticed that a condenser is connected across the breaker contact points. This is to protect the points against pitting and to assist the primary coil in inducing a high voltage in the secondary winding. (The operation of the condenser is taken up in Section 55.) The breaker points are normally held closed by spring tension and open only when the lobe of the cam lifts the movable contact arm. This cam is driven by the engine and rotates at one-half crankshaft speed in order to produce one spark in two revolutions of the crankshaft. The cam must be timed with the engine so that the spark will occur when the piston is nearing the end of its compression stroke.

When the switch is turned to the "ON" position, and the cam is in such a position that the breaker contacts are closed, current flows through the primary circuit from the positive (+) terminal of the dry cells, through the switch and primary winding of the coil (magnetizing the core as indicated), to the insulated terminal of the breaker. From here it crosses the breaker contacts and passes through the contact arm to the ground, returning through the ground to the negative (-) grounded terminal of the dry cells, thus completing the circuit. (A ground circuit is that part of the circuit in which the current travels through the engine and chassis frame, the frame or ground acting as a conductor the same as one wire.) When the primary current is interrupted by the cam lobe lifting the breaker contact arm so that the contact points are separated, the core demagnetizes thus causing the magnetic lines of force to collapse toward the core, cutting each turn of the primary and secondary winding. This sudden collapse of the magnetic lines induces a current in both windings causing it to flow around the core in the same direction as the original battery current. By having several thousand turns of very fine wire in the secondary winding, sufficiently high voltage will be induced in the secondary circuit to force a current to jump across the spark plug points, thus completing the circuit and giving the desired ignition spark within the cylinder. The path followed by the secondary current, as shown by the arrows, leads from one end of the secondary winding to the spark plug terminal, through the insulated electrode of the plug, jumping the gap between the plug points to the engine frame, and returning through the engine frame to the other end of the secondary winding. It will be seen that the primary winding and its current are used for magnetizing the core, while the current which is induced in the secondary coil, when the primary circuit is broken, is that used for the ignition spark.

A voltage will be induced in the secondary winding when the core is being magnetized as well as when it is being demagnetized, but owing to the fact that the core magnetizes more slowly than it demagnetizes, the induced voltage at this time is negligible. When the primary circuit is broken, the core, assisted by condenser action, demagnetizes very rapidly and induces a current of very high voltage in the secondary winding.

**55. The Condenser.**—The action of the primary circuit is very similar to that of the kick coil in a make-and-break ignition system, and the same kind of a flashy spark which occurs between the igniter points also occurs at the interrupter points when the primary circuit

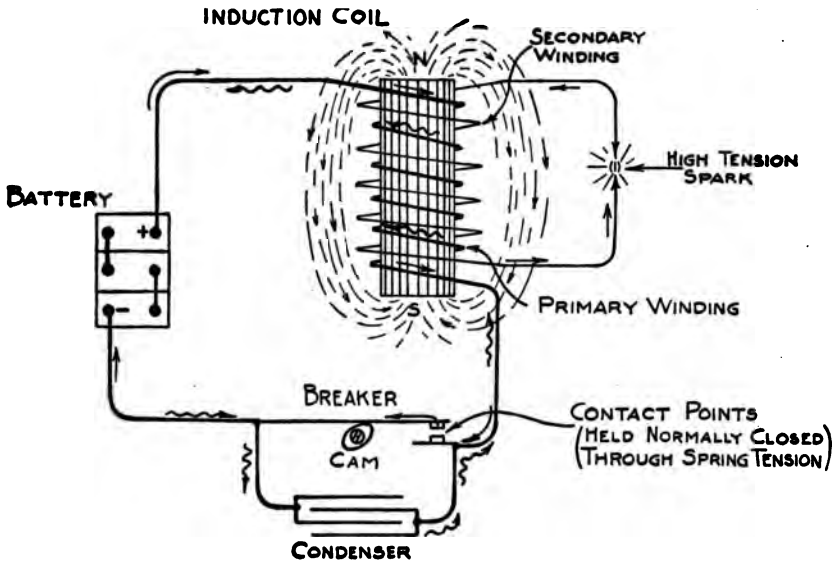

FIG. 73.—Operation of the condenser.

is broken. In the jump-spark ignition system this spark is prevented and the action of the coil greatly improved by the use of a *condenser*.

The condenser usually consists of two folded strips of tinfoil insulated from each other by other strips of paraffined paper, each strip of tinfoil being provided with a terminal. The condenser may also be made up of small sheets of tinfoil insulated by thin sheets of mica of approximately .002 in. to .003 in. in thickness. With this construction, the alternate sheets of tinfoil are connected in parallel, thus forming two groups, the sheets in each group being connected (usually soldered) along the edge, forming in all two common terminals for external connection. The two condenser terminals are connected to the interrupter terminals as shown in the circuit diagrams of Fig. 72 and Fig. 73. The condenser may be mounted either in the breaker



head or in the coil housing, preferably as near to the breaker points as possible. In either case, the condenser should be well protected against moisture or physical damage. *There is no electric circuit through a good condenser.* If, under operating conditions, current does pass through the condenser it is short circuited and must be replaced. The condenser has the property of being able to absorb and discharge an electric charge, and it is this characteristic which makes its use essential to jump-spark ignition.

Referring to Fig. 73, the operation of the condenser is as follows: When the break of the primary circuit occurs, the induced surge of current in the primary, which is in the same direction as the original battery current and which would otherwise cause an arcing between the contact points, rushes into the condenser and charges it. The

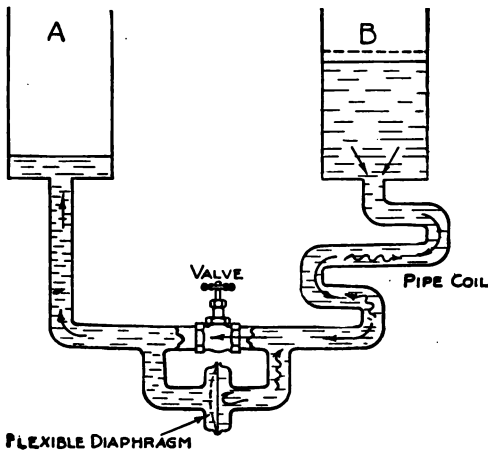

Fig. 74.—Water analogy explaining action of condenser.

side of the condenser which receives the surge is temporarily charged positive and the other side negative. Instantly, the condenser discharges back through the primary winding and battery in the opposite direction in an attempt to equalize the potential of the two sides. As this backward surge is opposite in direction to the original magnetizing current, it assists in quickly reducing the magnetism of the core to zero, thus aiding in securing the maximum voltage in the secondary winding.

In reality, the current surges or oscillates to and fro from the condenser before it finally dies out. The initial condenser discharge is represented by the crooked arrows in Fig. 73.

The action of the condenser may be compared to that of the flexible diaphragm shown in Fig. 74. When the valve is closed, suddenly cutting off the flow of water from tank B through the coil of pipe into tank A, the water depresses the diaphragm for an instant, due to the momentum attained by the water. The diaphragm will then rebound immediately, forcing a surge of water back through the pipe into B; in fact, the water will surge back and forth several times before it finally comes to a standstill in the pipe. This surging action of the water may be compared to the surging of the electric current upon successive discharges of the condenser.

Since the condenser is subjected to the full kick voltage of the coil,

namely, 150 to 300 volts impressed across the contact points at the instant the primary current is interrupted, it is evident that a good insulating material between the tinfoil plates is essential in order that no connection between the opposite plates may occur through a puncturing of this material. If a flashy spark occurs at the interrupter points, it is usually self-evident that the condenser has become either broken down (short circuited) or disconnected.

The capacity of a condenser depends on the size, number, and arrangement of the tinfoil plates, and upon the thickness and quality of the dielectric material between them. The actual number of square inches of tinfoil needed in a condenser depends upon the size of the wire and the number of turns in the coil windings; the shape and quality of the iron core; and upon the speed of the interrupter. Condenser capacity is usually determined experimentally and that capacity used which gives the most satisfactory ignition. The action of a good condenser of proper capacity results in intensifying the secondary current nearly 25 times. It also eliminates any arcing at the breaker points, when they are separated, thus preventing rapid pitting and wearing away at the contact points.

**56. The Safety Gap.**—Owing to the extremely high voltage induced in the secondary winding of an induction coil upon the interruption of the primary circuit, a gap of  $\frac{5}{16}$  in. to  $\frac{3}{8}$  in. known as a *safety gap* is usually provided across the ends of the secondary winding, in parallel with the gaps of the spark plug points. The purpose of this is to provide a by-pass for the high-voltage current in case a spark plug lead should become disconnected thus causing the secondary circuit to be opened, or, in case the spark plug points should become too far apart for the spark to jump when subjected to the high compression of the gas in the cylinder. In case such a break or extra high resistance should occur in the secondary circuit, which offers greater resistance to the high-tension current than the resistance across the safety gap, the spark will jump the safety gap, thereby safeguarding the winding of the coil against any excessive voltage which might puncture the insulation and cause short circuits.

**57. Spark Plugs.**—Figure 75 illustrates the internal construction of several typical spark plugs. The center terminal is insulated from the rest of the plug and the other terminal. The insulation between the center electrode and the body of the plug is usually either of *porcelain* or of *mica*. The outside terminal is in contact with the engine cylinder and is, consequently, grounded. The only way the current can get from one terminal to the other is across the air gap between them. The proper gap between the points for ignition systems used on automobile engines of normal compressions up to 80 lb. should usually be about  $\frac{1}{32}$  in. (.030 in.) or the thickness of a worn dime. This adjustment, however, may vary slightly with the type of ignition equipment used.

Some plugs are made with a single grounded electrode; others are made with two or more. Certain advantages are claimed for multiple-pointed plugs, chief of which is a surer spark. In time, the gap gradually widens, due to a burning of the points. Consequently, a single-point plug will need adjustment of the gap from time to time. In the case of plugs with several grounded points, it is claimed the electrodes will not burn up so fast, and, therefore, will require less attention.

A good serviceable plug will not short circuit, leak, or break down. Short circuiting is usually caused by a deposit of carbon on the porcelain or mica elements. This may be caused either by too rich a mixture, or by too much lubricating oil, or both. Good spark plugs are assembled so as to be gas-tight. This necessitates using good copper or asbestos gaskets of durable construction since it becomes necessary to disassemble the plugs from time to time for the purpose of removing carbon deposits. The

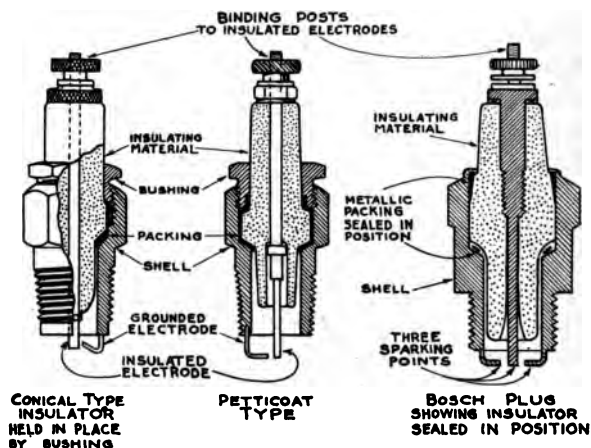

FIG. 75.—Sections of typical spark plugs.

insulation must be of high-quality material to confine the electric current to the insulated electrode; in fact, any current leakage through the porcelain or mica renders the spark plug practically worthless. Figure 76 shows a few of the many types of spark plugs now in use. Although the designs vary somewhat to suit varying conditions of service, the requirements mentioned above are fulfilled in each type.

In automobile and aviation engines of moderate compression, the voltage required to jump the gap of the spark plug points, when properly adjusted, is approximately 6,000 volts. This "break down" voltage, however, may vary a great deal, depending upon the density of the compressed gas, since the voltage increases or decreases in proportion to the increase or decrease of the gas density. The gas density in turn depends upon the compression, the proportion of gasoline and air, and the temperature of the compressed mixture. Thus it will be seen that in engines

of high compression the spark plug points should be adjusted a trifle closer than in engines of low compression in order to compensate for the increased resistance of the gas when subjected to the higher pressure and in order to insure a good ignition spark. Common practice is to set the



FIG. 76.—Types of spark plugs.

spark plug points to a gap of .025 in. to .030 in. for automobile engines with compressions less than 80 lb., and .020 in. for aviation engines with compressions up to 125 lb.

One of the important factors in the successful operation of a spark plug

is its proper installation in the cylinder or cylinder head. The location of the spark plug in the cylinder head is governed largely by the type of head used. The usual spark plug locations in the I-head, L-head, and T-head types of engines are shown in Fig. 77. This figure also shows the typical arrangement of the valves and the shape of the combustion chamber for each type of engine, both of which have consider-

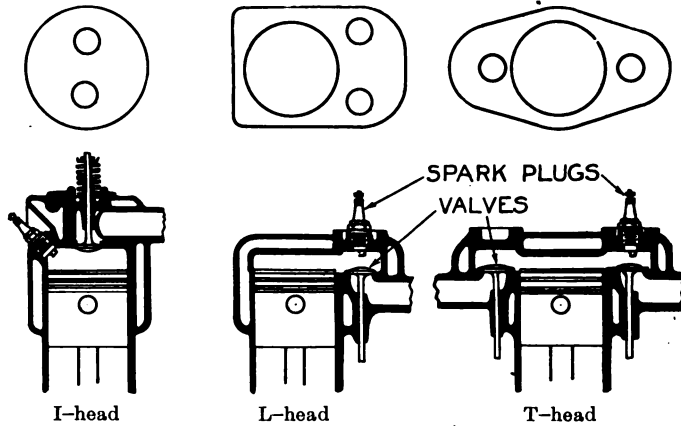

Fig. 77.—Arrangement of valves and spark plugs in various types of engines.

able influence on ignition. Since the cylinder head construction varies in thickness on the different types of engines, the spark plug shells are made in several different lengths so as to locate the sparking points in proper relation to the gases in the combustion chamber. The shell should be of such length that when the plug is screwed into place the inner edge of the shell comes flush with the inside of the cylinder head wall

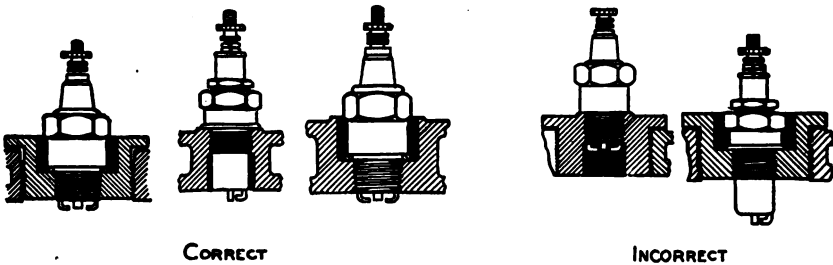

Fig. 78.—Correct and incorrect methods of installing spark plugs.

as shown in Fig. 78. If the shell extends beyond the inner surface of the cylinder, there is danger of the plug overheating, thus causing premature ignition. On the other hand, if the plug does not extend entirely through the hole into which it screws, a pocket is formed for the burned dead gases, and there is danger of misfiring, owing to the difficulty of the fresh gases in reaching the spark plug points. There is also danger of the plug fouling badly (short circuiting) by oil or carbon accumulation.

In order that the spark plugs used by different engine manufacturers may be made interchangeable, as far as possible, the dimensions of the shell portion have been standardized to conform to the dimensions shown in Fig. 79 as recommended by the Society of Automotive Engineers. The threaded portion is  $\frac{7}{8}$  in. in diameter and has a pitch of 18 threads per in. This is known as the S. A. E. standard. This size of plug has been adopted as standard on practically all present American makes of automobiles with the exception of three or four makes which use either the  $\frac{5}{8}$  in. diameter, 18 thread shell, or the  $\frac{1}{2}$  in. size having standard pipe threads. The latter size is standard for the Ford car.

SMALL HEX  $\frac{7}{8}$ " ACROSS FLATS. LARGE HEX.  $1\frac{1}{8}$ " ACROSS FLATS.

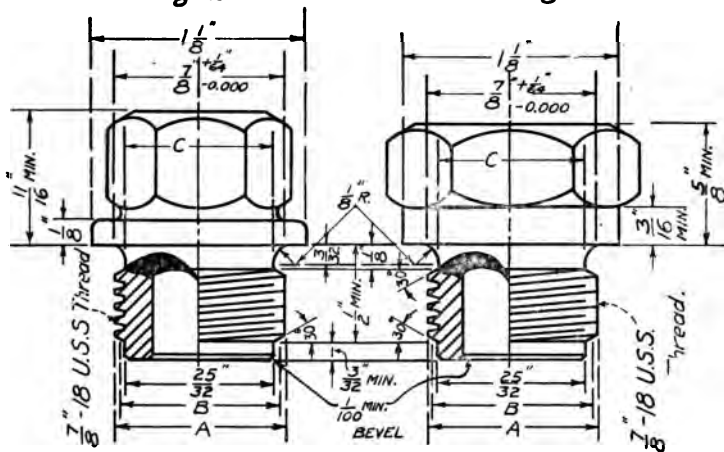

FIG. 79.—Spark plug shell dimensions.

The upper part of the spark plug shell is made in two sizes, as may be seen from Fig. 79, while the dimensions below the shoulder are identical for both sizes of shells. With these dimensions the spark plugs can be turned in by hand, using a wrench only for final tightening. The thread taps used should be made to dimensions as follows:

Diameters	Nominal Dimension	Thread Limits	
		Spark Plug	Tap
Outside (A).....	0.875	0.872 Min. 0.875 Max.	0.877 Min. 0.879 Max.
Pitch (B).....	0.839	0.836 Min. 0.839 Max.	0.841 Min. 0.843 Max.
Root (C).....	0.803	0.800 Min. 0.803 Max.	0.805 Min. 0.807 Max.

The nominal tap-drill diameter is  $1\frac{3}{16}$  in. or 0.8125 in.; the minimum diameter is 0.810 in. and the maximum 0.813 in.

*Spark Plug Terminal Threads.*—The standard thread used for spark plug terminals is No. 8-32 (0.164 in. dia.) A. S. M. E. standard.

**58. The Vibrating Induction Coil.**—The vibrating coil ignition system differs from the non-vibrating type chiefly in the addition of a vibrator for the coil and the employment of a *timer* instead of a *breaker* for opening and closing the primary circuit. The essential parts of the coil are a *core* of soft iron wire; a *primary winding* of coarse insulated wire; a *secondary winding* of fine insulated copper wire; a *condenser*; and a *vibrator*.

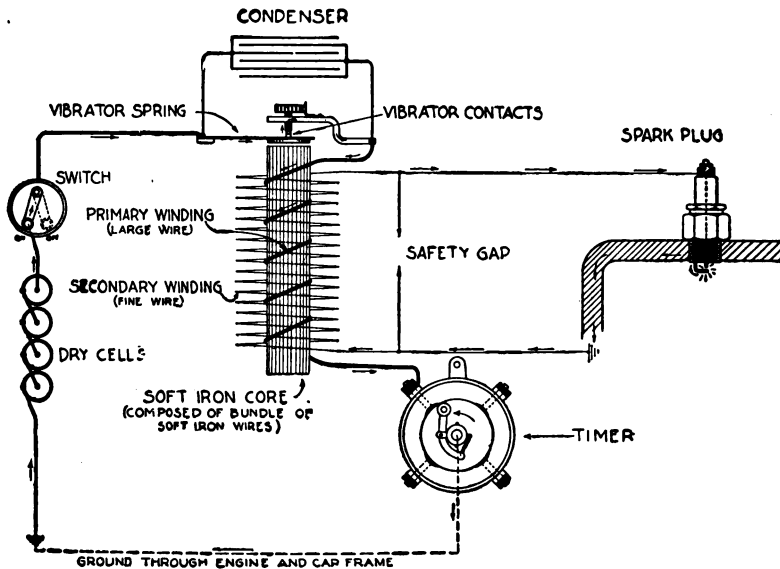

FIG. 80.—Simple jump-spark ignition system with vibrating coil and timer.

In Fig. 80 is shown a circuit diagram of a simple jump-spark ignition system using a vibrating coil with timer. There are two separate and distinct electric circuits, namely, the *primary* circuit, and the *secondary* circuit the same as in the non-vibrating system. The primary or battery circuit includes the battery, the switch, the vibrator, the primary winding of the coil, the timer, and the condenser. The condenser is connected across the vibrator points. The secondary circuit contains the fine or secondary winding of the coil and the spark plug. When the primary circuit is completed at the timer (which is usually driven by the camshaft of the engine), current will flow from the battery through the primary winding of the coil in the direction indicated by the arrows. The core of the coil thus becomes magnetized and as long as the current flows this core will have the properties of a magnet. The core exerts a pull on the

iron disc or *armature* attached to the end of the vibrator and in so doing separates the contact points on the vibrator from the stationary contact. This breaks the primary circuit and the current ceases to flow. The core then loses its magnetism and the vibrator returns to its former position. In so doing, it reestablishes the primary circuit and the action is repeated. Thus, as long as the primary circuit is closed by the roller making contact with the segment of the timer, the vibrator will vibrate rapidly, similar to the vibrator of an ordinary electric doorbell.

Each time the vibrator opens, breaking the primary circuit, the magnetic field dies away very quickly followed by a high-tension spark at the plug. The flashy spark which would naturally occur at the vibrator points is absorbed by the condenser which is connected across the points. Since the vibrator makes and breaks many times during each contact of the timer, a shower of sparks is delivered at the plug. These sparks begin at the instant the timer contact is made and last throughout the period of contact.

**59. The Three-terminal Coil.**—Many of the coils used on automobile ignition systems have only three terminals instead of four. In Fig. 81 is shown a typical three-terminal coil such as is used on the Ford car. One end of the secondary winding is joined to one end of the primary, and the junction connected to one of the terminal binding posts which, when connected in the system, leads to the ground through the primary wiring. The other end of the secondary has a separate terminal which is connected to the spark plug.

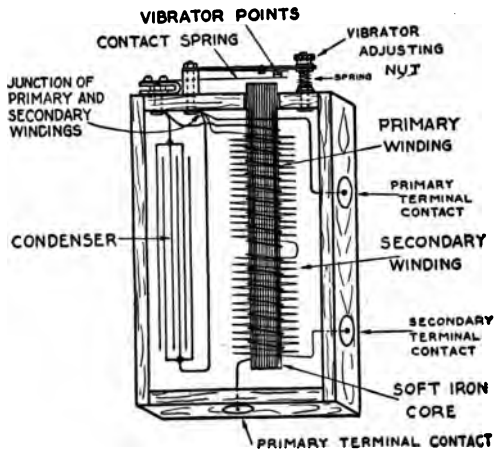

FIG. 81.—Ford induction coil, showing typical three-terminal coil.

**60. The Vibrating Type Ignition System.**—Where vibrating coils are used for ignition on a multiple cylinder engine, it is customary to use a coil for each cylinder. These coils are usually enclosed in an upright box, as shown in Fig. 82, which is a coil-set for a four-cylinder engine. The box is fitted with interchangeable slip-type coil units such as that in Fig. 81. The connections for these coils are made by contact springs in the coil box bearing on the metal contacts of the coil as shown in Fig. 83. This makes it possible to remove any of the coils without disconnecting any of the wiring. The switch on the front of the box permits the primary current to be used from either a battery or low-tension magneto.



This system may also be used with two independent batteries, one being held in reserve.

Figure 83 shows the circuit diagram of a typical vibrating coil ignition system for a four-cylinder engine using either dry batteries or low-tension magneto as the source of current supply. This is similar to the Ford system of ignition which is taken up in detail in Chapter VI.



FIG. 82.—Ford four-cylinder coil-set.

**61. Timers.**—The timer may be defined as a revolving switch driven by the engine for the purpose of connecting the source of primary current supply to the proper vibrating induction coil at the proper time. It is, consequently, always placed in the primary circuit.

The timer used on the Ford engine is shown in Fig. 84. The inside or rotating part is fastened to, and rotates with, the camshaft at one-half crankshaft speed.

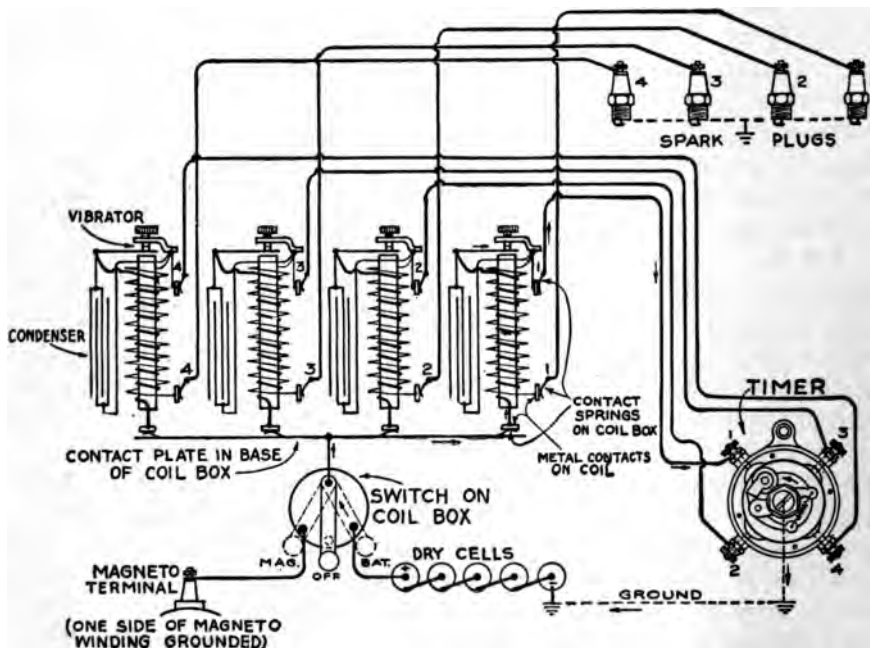

FIG. 83.—Diagram of four-cylinder vibrating coil ignition system.

When the roller comes into contact with one of the four terminals on the timer housing, the primary circuit is completed through the coil which is connected to that terminal, causing its vibrator to operate and a series of

sparks to occur in rapid succession at the plug. The housing of the timer does not turn with the camshaft, but can be shifted forward or backward in respect to the camshaft and roller so as to advance or retard the time of the spark.

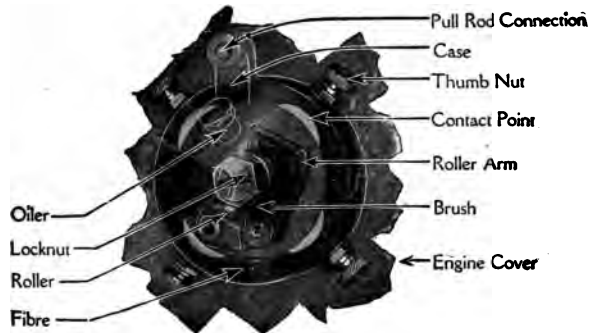

FIG. 84.—The Ford timer.

The timers, when used for six-, eight-, and twelve-cylinder engines, are similar to the above but instead of four terminals, have six, eight, or twelve insulated terminals equally spaced in the housing.

**62. Master Vibrators.**—A master vibrator is a single vibrator or interrupter that takes the place of the separate vibrators of the coil units on a multi-cylinder engine, doing away with the separate vibrator adjustment for the different coils. With this system one fast vibrator with a good condenser will produce sparks of like intensity at each of the plugs. Figure 85 shows the external view of a K-W master vibrator with a three-position switch which permits the use of a low-tension magneto or a battery to furnish the current for ignition. A master vibrator is quite similar in construction to a vibrating coil except that it has no secondary winding. It consists of an iron core, a switch, and a vibrator across the points of which a condenser is connected. The master vibrator is connected in series with the batteries and the coils so that the primary current passes through the master vibrator coil before going to the induction coils. The master vibrator thus operates regardless of which cylinder is firing. Figure 86 shows the Pfanstiehl master vibrator, which is cylindrical in shape.



FIG. 85.—K-W master vibrator.

When a master vibrator is installed in connection with coils having separate vibrators, a change is made in the coils, cutting out or short circuiting the separate condenser and vibrators. This may be done by simply screwing down each of the vibrator contacts so that they make firm contact and cannot vibrate. The three-position switch on the coil box is also discontinued and that on the master vibrator used instead. Figure 87 shows a wiring diagram for a four-cylinder coil-set with a master vibrator such as is often equipped on the Ford car. This diagram shows the switch thrown to "Magneto" position so that the magneto is furnishing the primary current. The firing order is 1, 2, 4, 3, and the connection is shown to give a spark in cylinder No. 1.



FIG. 86.—Pfanstiehl tubular type master vibrator.

The demand for such a device as a master vibrator has been brought about by the difficulty experienced in securing uniform adjustment of the various vibrators, by

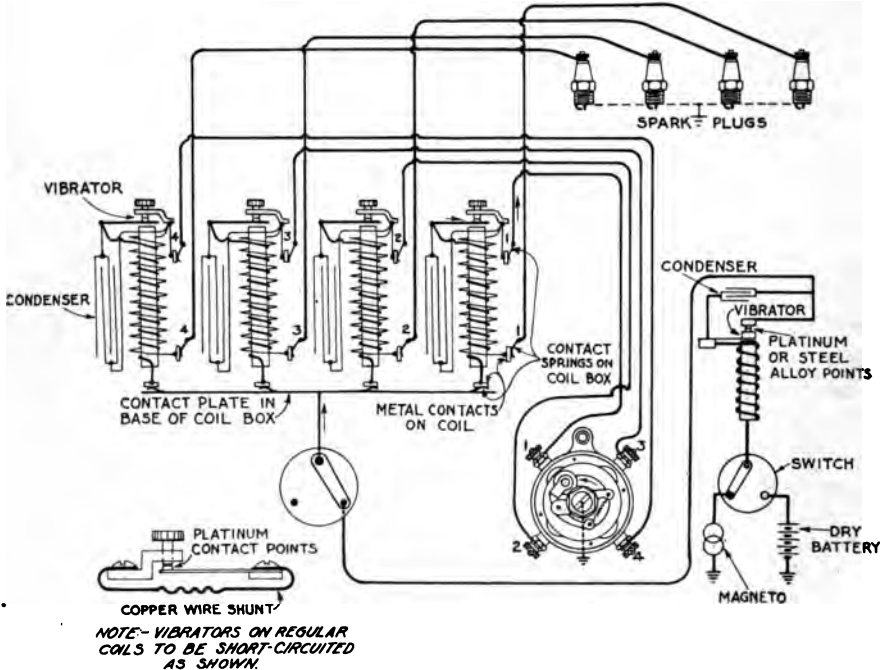

FIG. 87.—Wiring diagram of four-cylinder ignition system using master vibrator in connection with four vibrating type coils.

deterioration of the vibrator points, and by the frequent troubles encountered with defective condensers, it being about as cheap to install a

master vibrator as to replace the expensive points or to buy new coils. As the condensers and vibrators of the individual coils are inoperative when the master vibrator is used, any defects in those parts will not prohibit their use in the new scheme. One advantage in using a master vibrator is due to the fact that sparks of equal intensity are delivered to all the spark plugs as the result of one vibrator adjustment.

**63. Spark Advance and Retard.**—On a variable speed gasoline engine it is very essential that the time at which the spark occurs in the cylinder be changed according to the engine speed, since it takes a certain length of time for the explosion to take place regardless of the engine speed. When the engine speed is high, the spark must occur before the piston reaches dead center in order to have the full force of the explosion exerted when the piston has just passed the center position. When the engine speed is low, the spark can occur later and the force of the explosion will be exerted just after dead center. It is necessary when starting the engine that the spark occur when a piston is approximately on dead center; but when the engine must start on ignition from a high-tension magneto, the spark can occur slightly before dead center. This is especially true when an electric starter is used for cranking, since the engine is cranked at a higher speed and with sufficient momentum stored in the flywheel to carry the pistons past the dead center positions.

These various considerations demand that the position of the spark be made variable. This is usually done by shifting the timer, or interrupter housing, causing the break of the primary current (and, consequently, the spark in the cylinder) to occur earlier or later. The position of the spark in most cases is governed by the spark control lever on the steering wheel. In starting the engine, the spark should be retarded so that it will not occur until the piston is starting on its downward stroke. The spark should then be advanced as the engine increases its speed. If the spark is too far advanced, there will be a decided knock in the cylinders. The best results are obtained with the ignition advanced as far as possible without causing the engine to pound.

**64. Principles of Ignition Timing.**—Correct ignition timing is one of the most important points in engine economy. The best efficiency will be obtained when the time of ignition is so regulated that the greater part of the combustion occurs while the crank is passing the head or upper dead center. If any great part of the combustion occurs before the dead center is reached, there will be an undue pressure exerted against the further motion of the piston in completing the compression stroke. If the combustion is delayed, the full fuel energy will not be available for the whole expansion stroke and there will be a consequent loss in the amount of work secured from the fuel.

The rate at which the flame spreads through the fuel mixture depends on the quality of fuel and the mixture. A weak mixture will burn more slowly than a well-proportioned one. An overly rich mixture will also burn slowly. A fuel low in heating value will also burn more slowly than one high in heat units. Fundamentally, the rate of flame propagation through the charge depends upon the intensity of the heat generated by the combustion. The ignition spark starts combustion in a small sphere surrounding the spark plug points. The heat thus generated is transmitted to the surrounding charge, which in turn burns and passes the heat on to succeeding layers. The rate of propagation thus depends on the intensity of the heat generated in each unit of volume of the mixture. Weak gases or mixtures must, therefore, mean slower combustion. The state of compression also affects the rate of burning. If the charge is compressed into a smaller space, the intensity of the heat generated in each unit of space is greater; the flame also has a shorter distance to travel to ignite the whole charge.

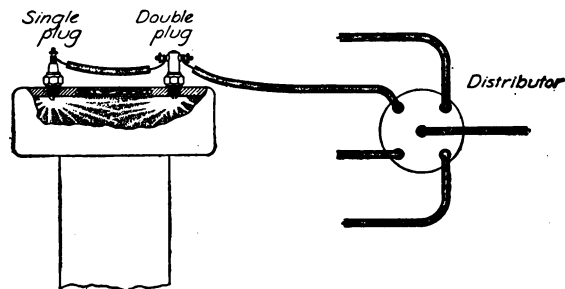
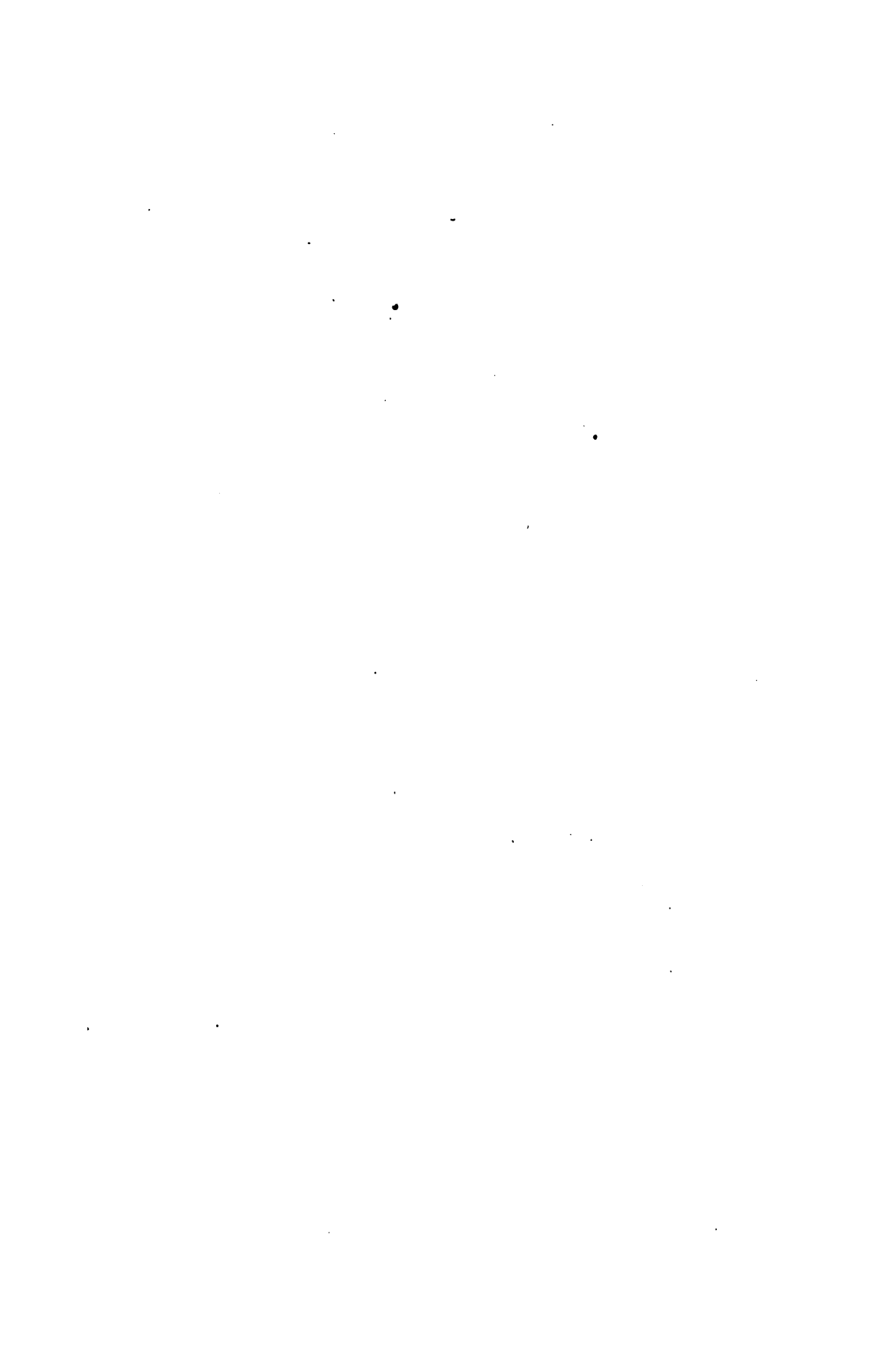

FIG. 88.—Series plug ignition system.

Thus it is evident that the shape of the combustion chamber has considerable influence on the time required for flame propagation and the consequent power and fuel economy of the engine. In this respect the I-head type of engine has the advantage over the L- and T-head types, Fig. 77, since it has the most compact combustion space and, consequently, the shortest distance for the flame to travel.

The location of the spark plug is also important in this respect. If it is located near the center of the combustion chamber, the flame will spread through the whole mass more quickly than if ignition occurs at one corner of the combustion chamber. To lessen the time for securing combustion, T-head engines are sometimes provided with two spark plugs located at distant points in the cylinder head, usually one plug over each valve, and arranged so that a spark will occur at the same instant in both plugs. This arrangement requires the use of one special plug, known as a *series plug*, in which both electrodes are insulated, the two plugs being connected in series as shown in Fig. 88.

It will be evident that the procedure for timing the ignition apparatus with the engine depends largely upon the type of ignition system used, the characteristics of the engine, and the conditions under which it is to operate. Since there is no particular gain in having the spark occur much after the piston has passed the upper dead center position, it is usually advisable to fix the time of the spark on the maximum retard in relation to the engine crankshaft, rather than to fix the time of the spark for maximum advance. This will give the operator the full available advance range through which he may advance the spark ahead of dead center, as the engine speed increases, in order to obtain the best performance of the engine. Thus it will be seen that the chief aim in ignition timing is to fix definitely the occurrence of the spark so that it will occur in the cylinder when the piston is approximately on upper dead center position at the end of its compression stroke with the ignition breaker or timer in full retard position. It should be remembered that in ignition systems using a non-vibrating coil and breaker, the spark occurs at the plug the instant the breaker contact points separate; while, in the case of a system using vibrating coils with a timer, a shower of sparks will occur at the plug the instant the timer contact is made. The exact methods employed in ignition timing will be taken up later in connection with the various types of ignition systems.



## CHAPTER IV

### MODERN BATTERY IGNITION SYSTEMS

**65. Construction of a Typical Battery Ignition System.**—The main parts of a modern automobile battery ignition system are: a *storage battery*, a *high-tension non-vibrating induction coil*, a *breaker*, and a *distributor*. A typical installation of such a system is shown in Fig. 89. The source of current is the storage battery, which also supplies current for the starting and lighting system. The breaker and high-tension distributor are usually combined into a single unit driven either through

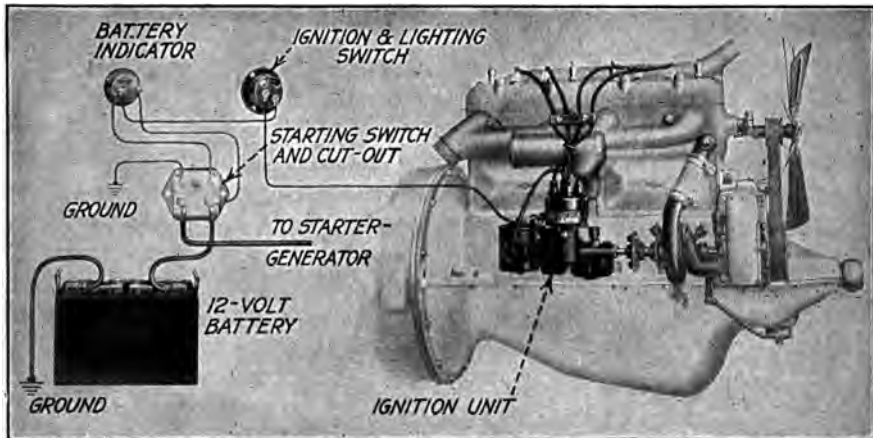

FIG. 89.—Installation and wiring of North East ignition system on Dodge.

spiral gears on one end of the generator armature shaft, as in Fig. 90, or by a separate shaft similar to the method of driving a magneto as shown in Fig. 89.

The induction coil is usually mounted close to the breaker unit, common locations for it being on top of the generator as in Fig. 90; on a bracket on the side of the engine; or on the back of the dash. The ignition switch may be an independent switch; or, as is more often the case, it may be combined with the lighting switch. This switch may be mounted either on the instrument board or on the steering column within convenient reach of the driver.

A wiring diagram of a typical automobile battery ignition system for a six-cylinder engine is shown in Fig. 91. As may be seen, the breaker points and the distributor are operated by a single vertical shaft, the



distributor arm or block being carried on the upper end of this shaft immediately above the cam which actuates the breaker points.

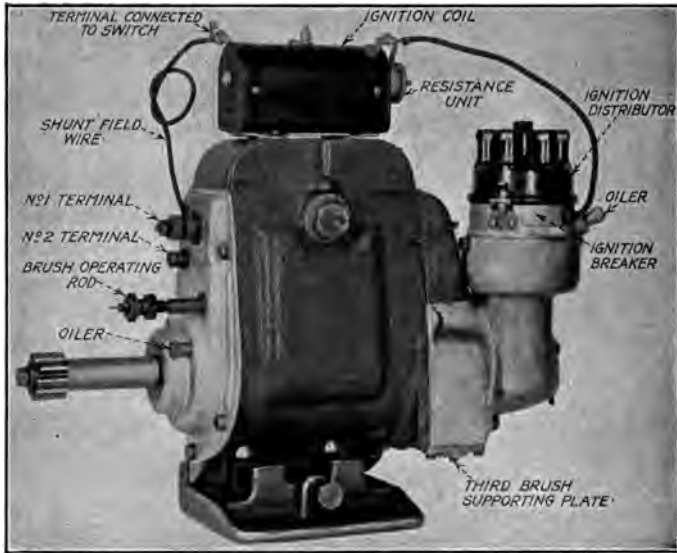

Fig. 90.—Delco ignition equipment mounted on motor generator for Buick Six.

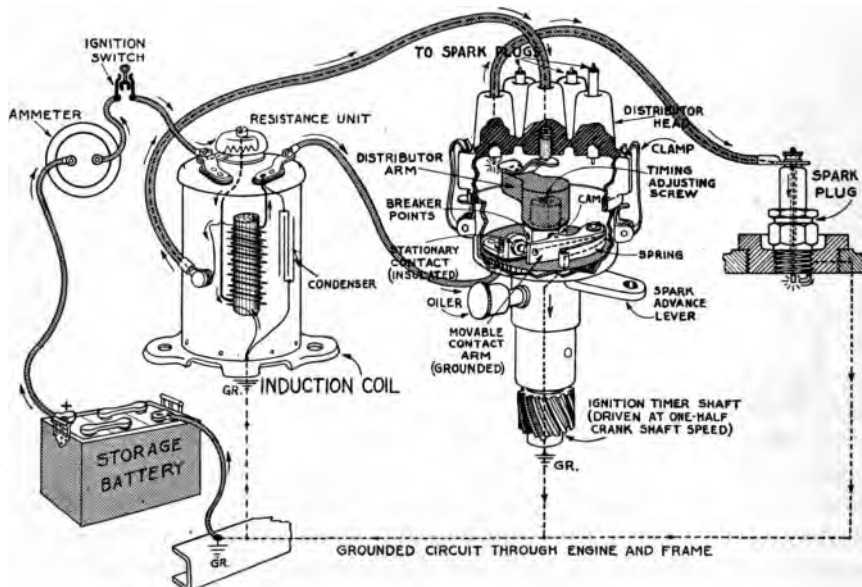

Fig. 91.—Typical battery ignition system.

In all four-, six-, eight-, or twelve-cylinder four-stroke cycle engines, such as used in automobiles, trucks, tractors, and airplanes, all of the

engine cylinders must fire in two revolutions of the crankshaft. This means that for each revolution of the engine crankshaft one-half of the total number of cylinders must fire and must receive an ignition spark. Thus the ignition system must deliver to the engine cylinders two sparks for a four-cylinder engine, three sparks for a six-cylinder engine, four sparks for an eight-cylinder engine, and six sparks for a twelve-cylinder engine, during each revolution of the crankshaft.

This is made possible by using a four-, six-, eight-, or twelve-lobed cam for interrupting the primary circuit, and a high-tension distributor with as many equally spaced segments as there are cylinders for directing secondary current to the various plugs in their proper order of firing. With this arrangement, the cam and distributor are both driven at the same speed, namely, one-half that of the crankshaft.

Since the spark occurs in the cylinder at the instant the breaker points open, it is very essential that the cam lobes be ground and spaced very accurately so that the spark will occur in each cylinder at exactly the same point in the revolution. The cam lobes and distributor segments are, therefore, spaced to correspond to the angle passed through by the crankshaft during the period between successive cylinder explosions. This crank angle is normally  $180^\circ$  or one-half of a revolution for a four-cylinder engine,  $120^\circ$  or one-third of a revolution for a six-cylinder engine,  $90^\circ$  or one-fourth of a revolution for an eight-cylinder engine, and  $60^\circ$  or one-sixth of a revolution for a twelve-cylinder engine. One complete revolution is  $360^\circ$  so that the angles between the cams may be readily determined by dividing  $720^\circ$  by the total number of engine cylinders. For example: the crank angle between explosions in a six-cylinder engine is  $720^\circ \div 6$  or  $120^\circ$ . Likewise, in a twelve-cylinder engine this angle is  $720^\circ \div 12$  or  $60^\circ$ .

**66. The Breaker.**—The function of the breaker or *interrupter* is to make and break the primary circuit, thereby energizing the induction coil and producing a spark at the plug at the proper time. Where a non-vibrating coil is used, the secondary spark occurs at the instant the contact points open. These points consist of two small contact pieces, usually tungsten alloy or platinum, one of which is stationary while the other is mounted on a pivoted arm as shown in Fig. 91. This arm is made to bear against the cam by spring tension, with the points held normally in contact. As the cam revolves, each lobe presses against the contact arm separating the points about .020 in. The opening of the contact points interrupts the current in the primary winding of the coil thus permitting the core to demagnetize and causing a high-voltage current to be induced in the secondary winding. The points being made of tungsten alloy or platinum, both have extremely high melting points, and will withstand burning and pitting due to any sparking that may occur when the contacts open. To prevent this sparking as much as possible, a condenser is used, it being electrically connected across the two contacts.

**67. The Distributor.**—As previously explained, the function of the distributor is to direct the secondary current from the induction coil to the various spark plugs of a multi-cylinder engine in the proper order of operation. The distributor head or cap has a center terminal which connects with the secondary terminal of the induction coil, and as many more metal segments or terminals equally spaced around it as there are spark plugs. The head is usually molded of a very high resistant insulating material such as *Bakelite* or *Condensite* which is moisture proof and possess high insulating properties even under excessive heat. The terminals are of metal alloy molded in position and terminating on the underside in the form of either a segment flush with the surface of the head, or in the form of a pin as in Fig. 91.

The center terminal, to which is connected the high-tension cable from the induction coil, has a button or brush on the underside, usually of carbon, which makes electrical contact with the center point of the spring or segment on the distributor arm. This arm or *rotor*, which is usually a molded block of the same material as the head, fits upon the shaft in only one correct position relative to the cam, so that, as it rotates, its distributing button or segment always comes opposite the correct terminal in the head to conduct the spark to the proper cylinder when the cam separates the breaker points. In some distributors such as the Delco, North East, and Westinghouse the end of the distributing arm makes rubbing contact with the segments in the head by means of either a metal button



FIG. 92.—Method of cleaning distributor head.

or carbon brush, while in other types such as the Remy, Atwater-Kent, and Connecticut, the outer end of the distributor segment merely rotates close to the terminal extensions without quite touching them. In this type, the secondary current must leap the small gap (usually not over  $\frac{1}{64}$  in.) between the segment and the terminal extension in order to complete its current.

The distributor head is usually held in place by two spring clips which fit only when the head is in its proper position. By simply removing the head, the distributing arm and breaker mechanism are readily accessible for inspection and adjustment. On systems where the distributor makes a wiping contact, it is advisable to remove the cap about once a month, or each 1000 miles of travel, and wipe the track clean, using a rag slightly moistened with vaseline as shown in Fig. 92. This will keep the distributor track polished and prevent the rotor button from sticking and cutting the track.

**68. The Resistance Unit.**—The resistance unit, Fig. 91, which is very generally used on automobile storage battery ignition systems, plays a very important part in the operation of the system and serves as a protective device to the coil and battery in case the switch is left "ON" with the engine not running.

It consists usually of a number of turns of resistance wire of either German Silver or a special Nickel-Chrome alloy, commonly known as "Nichrome," connected in the primary ignition circuit. The important characteristic of this wire is its property of increasing its resistance as it is heated up, the change in resistance being used to control the current flowing in the circuit. For this purpose "Nichrome" wire is more generally used since its increase in resistance is practically in direct proportion to its increase in temperature up to a dull cherry red heat (approximately 1400°F.), which temperature may be considered the highest at which the unit will operate normally. In case the ignition switch is left in the "ON" position with the engine not running and with the breaker closed, the resistance wire will heat up immediately, due to the current flowing, accompanied by a sudden rise in the resistance. This will cause the current discharge from the battery through the primary winding to decrease sufficiently to protect the coil against damage from overheating and the battery against rapid discharge.

**69. Effect of the Resistance Unit upon Ignition.**—It will be seen that the period during which the breaker contact points remain closed at high speed is exceedingly brief, while, at low speed, the contacts remain closed for comparatively longer periods of time. This causes the current consumption to be slightly greater at low speeds. In order to limit the increase of primary current to an amount which will not overheat the coil, the resistance unit is connected in the primary circuit in series with the coil and breaker, it being usually mounted either on top of the coil or on the side of the breaker housing. The effect of a slight increase of current through the circuit at low speeds is to heat up this resistance unit, thus increasing its resistance. This change in resistance automatically decreases the current at the lower speeds yet permits sufficient current to flow through the coil at high speeds to produce an effective spark.

It will also be seen that the resistance unit tends to equalize the intensity of the secondary spark at high and low engine speeds, due to its change in resistance and the difference in the value of the primary current at different speeds. The period of time which the primary current has for magnetizing the core will, of course, decrease in proportion to the increase in engine speed; consequently, since it requires a certain length of time for the core to become fully magnetized (usually .001 to .02 of a second, depending upon the design and construction of the coil), there is a tendency at high speed for the breaker to interrupt the primary current before the core is fully magnetized, thus decreasing the intensity of the

secondary spark. This is counteracted, to a certain extent, by the decrease in temperature and resistance of the resistance unit at high speeds, as a decrease in resistance will permit a larger momentary flow of current through the primary winding during the brief period the breaker points are closed. By thus controlling the primary current, the intensity of the secondary voltage is kept more nearly uniform at the different speeds of the engine.

The resistance unit also assists the coil to produce a hotter spark when the battery voltage is low since at that time the current is correspondingly low, and the temperature and resistance of the unit do not increase greatly.

**70. Automatic and Manual Spark Advance.**—In several modern automobile ignition systems, means are provided by which the posi-

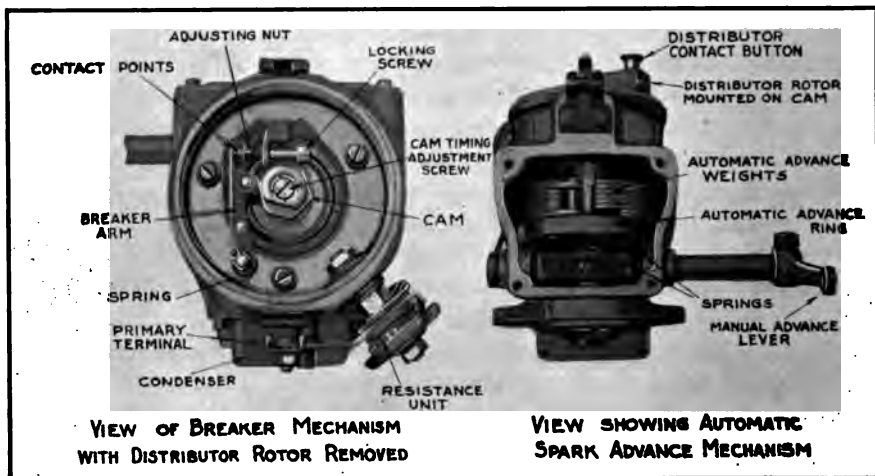

FIG. 93.—Delco interrupter and automatic spark advance mechanism.

tion of the spark is advanced and retarded automatically with the changes in engine speed. The purpose of this is to relieve the driver of the responsibility and uncertainty of correctly gaging the proper position for setting the spark control lever during normal driving speeds. Figure 93 shows the Delco ignition breaker and automatic spark advance mechanism as used on the Hudson Super-Six.

As can be seen from this figure, the automatic advance mechanism is in the form of a revolving weight type governor mounted on the timer shaft below the interrupter cam. The weights are carried by a ring which is mounted on a short hollow shaft integral with the cam. Above the cam is mounted the distributor arm or *rotor* which rotates with it. The entire mechanism is arranged so that, as the engine speeds up and the weights spread outward against the resistance

of the spring, the ring and cam are shifted in a forward direction in respect to the timer shaft. This has the effect of advancing the spark automatically to the correct position in proportion to the engine speed. As the engine speed decreases, the springs pull the weights inward and the spark is retarded automatically.

The manual spark advance lever is connected to the spark control lever on the steering wheel and is for the purpose of securing proper timing and hand control of the spark under various conditions such as starting, difference in gasoline, variable weather conditions, and at extremely high speeds, requiring spark control beyond the automatic advance range. Other types of automatic spark advance mechanism will be discussed in connection with the system on which it is used.

**71. The Atwater-Kent Ignition System, Type K-2.**—The Atwater-Kent battery ignition system is made in two principal types, the *open circuit* type in which the interrupter points are normally open, and the *closed circuit* type in which the interrupter points are normally closed. The open circuit type system was developed primarily for use with dry cells, while the closed circuit type was developed for use with storage battery and generator.

A typical model of the Atwater-Kent open circuit type system is the type *K-2*, which has been widely used on such cars as the Hupmobile, Peerless, King, Franklin, and Chalmers. Several of these cars, however, have recently changed to the closed circuit type Atwater-Kent system commonly known as type *CC* or *CA*. The principal parts of the type *K-2* system are: the ignition breaker and distributor unit or *unispark* as shown in Fig. 94 and Fig. 95; and the non-vibrating underhood type of induction coil as shown in Fig. 96. The switch may be a simple key switch combined with the lighting switch of the car or it may be a special polarity changing type mounted independent of the lighting switch, as shown in Fig. 97, the function of which is to reverse the direction of the primary current through the interrupter points each time the switch is turned on.

The chief feature of this system is the special form of contact mechanism. This is located immediately below the distributor as may be seen in Fig. 95 which gives an exploded view of the entire unit. The important feature of the contact mechanism is that the length of contact is independent of engine speed, thus giving the same intensity of spark at racing speeds as when slowly cranking the engine.

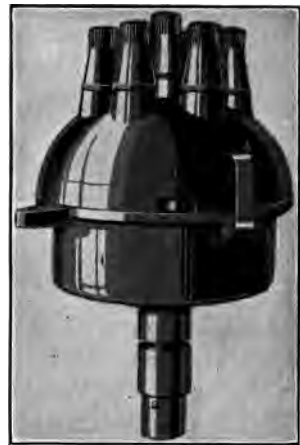

FIG. 94.—Atwater-Kent Unispark, Type K-2.

The action of the contact mechanism is shown in Fig. 98. The four views show the movement described in producing one spark. The



FIG. 95.—Construction of Atwater-Kent ignition unit, type K-2.

principal moving parts are: the hardened steel rotating shaft in the center with as many notches as there are cylinders; the lifter; the latch;



FIG. 96.—Atwater-Kent under-hood coil.



FIG. 97.—Atwater-Kent polarity reversing ignition switch.

and the contact spring. The contact points are normally open. The contact is made and broken by the action of the lifter spring in draw-

ing the lifter back, or after the lifter has become unhooked from the notched shaft. When the lifter is pulled forward by the notched shaft, it does not touch the latch. It is pulled forward until it reaches a point where it unhooks from the notched shaft and is then snapped back by the lifter spring, striking the latch as it returns. The latch, being struck by the lifter, presses against the contact spring and closes the points for a brief instant, opening immediately after the lifter passes. With the latch and lifter returned to their original position, the mechanism is again ready to repeat the same operation for producing the next spark. The spring action makes the speed of the break independent of the speed of the engine. It also makes the time of contact uniform, and, since the period of contact is so brief, the system draws the least possible current from the batteries. This makes it particularly adapted for use with dry cells.

It is while the contacts are making momentary contact that the current flows through the primary winding of the ignition coil. Then,

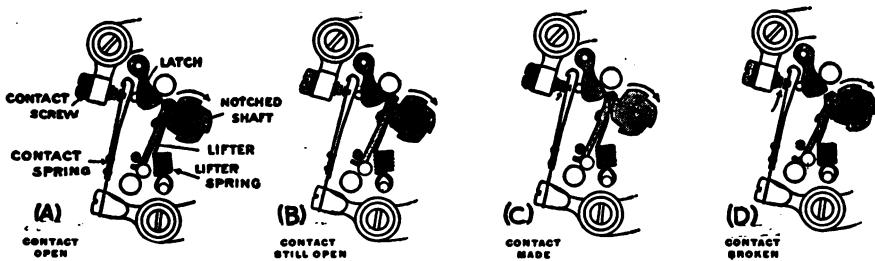

FIG. 98.—Operation of Atwater-Kent contact mechanism for type K-2 ignition system.

when the points separate, the coil demagnetizes and a high-voltage current is induced in the secondary winding. The secondary current is led to the center terminal of the distributor, from which point it is directed to the various spark plugs in their proper order of firing by the revolving distributor block, Fig. 99.

Owing to the very short period in which the contacts are together and the consequent short duration of the current flow, the coil used with such an interrupter must be designed to magnetize or *build up* very rapidly. This is due to the fact that it requires an appreciable amount of time for the primary current to rise to its full value, depending upon the quality and shape of the core, and the number of turns and size of wire in the primary coil winding. Thus it will be seen that an induction coil designed to operate with an interrupter of the closed circuit type will not operate satisfactorily with one of the open circuit type since the points will open before the core becomes fully magnetized. On the other hand, a coil intended for the open circuit type interrupter will be of too low resistance to give satisfactory service with a closed



circuit type of breaker, as the current flow will be abnormally high, usually causing rapid burning of the contact points and possible injury to the condenser.

A complete wiring diagram of the type K-2 system using a switch of the polarity changing type is shown in Fig. 99. The switch has two positions "OFF" and "ON." When the switch is turned "ON," if terminal *B* is connected to *S*, and *B'* to *S'*, the current will flow as indicated by the arrows. The next time the ignition is turned on, by turning the switch another quarter turn in the same direction, the connections in the switch are reversed, connecting *B* to *S'*, and *B'* to *S*. This reverses the direction of the primary current through the unisparker. The purpose of this is to equalize the transfer of metal

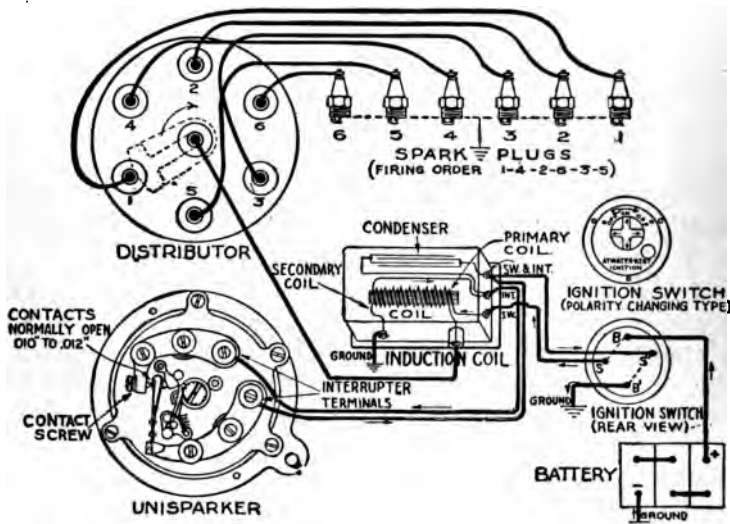

FIG. 99.—Wiring diagram for Atwater-Kent ignition system, type K-2.

by the action of the spark at the point of contact, thereby decreasing the wear and prolonging the life of the points.

*Contact Point Adjustment.*—The normal gap between the contact points is from .010 in. to .012 in.—never closer. When the gap becomes too wide, due to wear, the engine will be hard to start and will fire irregularly. The head of the contact screw, Fig. 99, is set up against several thin washers. A sufficient number of these washers should be removed to give the correct gap when the screw is set up tight.

The contact points are made of purest tungsten, a material which is many times harder than platinum. When the contact points are working properly, small particles of tungsten are carried from one point to the other, sometimes forming a rough surface, characterized by a dark gray color. This roughness does not in any way affect the proper working

of the points, owing to the fact that the rough surfaces fit into each other perfectly. However, when it becomes necessary to take up the distance between these points, due to natural wear, it is advisable to remove both contact screw and spring contact arm, and dress down the high spots with an oil stone or a new fine file. This makes it possible to obtain a more accurate adjustment and eliminates danger of any high points on the contacts touching each other when the parts are at rest.

*Automatic Spark Advance Mechanism.*—The mechanism for automatically advancing and retarding the spark, as shown in Fig. 100, is located in the housing immediately below the interrupter. It consists of a system of weights and springs or governor arranged so as to advance the spark automatically as the engine speed increases. The



Motor stopped or running slowly.

Motor at high speed.

Fig. 100.—Atwater-Kent automatic spark advance mechanism.

timer shaft is divided, the upper portion being notched for operating the contact mechanism. As the speed increases, the weights fly outwardly, due to centrifugal force, shifting the upper part of the shaft more and more ahead of the lower or driving shaft, thus causing contact to occur earlier and thereby advancing the spark. The relative positions of the governor weights at high and low speeds are shown in Fig. 100. As the speed of the engine is reduced, the pull of the springs causes the weights to move inwardly, turning the upper or notched end of the shaft backward, or reverse to the direction of rotation of the driving shaft, thereby retarding the spark. The total amount of automatic spark advance at high speed is from  $30^{\circ}$  to  $40^{\circ}$ . This is indicated in Fig. 100 by the position of the offset slot in the top of the notched shaft shown in the right-hand view compared with that in the left-hand view which shows its low speed position.

*Timing the Spark.*—Since the type *K-2* is not generally used with a spark control lever it should be installed so as to allow a small amount of angular movement for the initial timing adjustment. In other words, the socket into which the unisarker fits should be provided with a clamp which will permit the unisarker to be turned and locked rigidly in any given position.

In timing, the piston in No. 1 cylinder should be raised to upper dead center between compression and power strokes. The clamp which holds the unisarker should then be loosened and the unisarker (the entire ignition unit) slowly and carefully turned backwards or counterclockwise (opposite in direction to the rotation of the timer shaft) until a click is heard. This click occurs at the exact instant of the spark. At this point, the unisarker should be clamped and care taken not to change its position. The distributor cap, which fits only in one position, should then be removed and the position of the distributor block on the end of the shaft noted. The terminal to which it points must be connected to

No. 1 cylinder. The other cylinders should then be connected in turn to the other terminals in their proper order of firing, bearing in mind the direction of rotation of the timer shaft.



FIG. 101.—Atwater-Kent ignition unit, type CC.

When timed in this manner, the spark will occur in each cylinder exactly on *dead center* if the engine is turned over slowly. At cranking speeds and for safe starting, the spark is retarded automatically by the governor, and, as the speed increases, the spark is advanced

automatically, thus requiring no attention on the part of the driver.

**72. The Atwater-Kent Ignition System, Type CC.**—The Atwater-Kent ignition system type *CC* is of the closed circuit type developed for use on cars equipped with electric starting and lighting equipment and is intended to operate on current from a storage battery. It consists of a breaker and distributor unit mounted with a non-vibrating coil on a base as shown in Fig. 101. The unit has the same general dimensions as the standard high-tension magneto and is driven in the same manner. For this reason it is termed a magneto replacement unit. Figure 102 shows the Atwater-Kent installation on the 1918 Maxwell engine.

The principal feature of the system lies in the design of the breaker mechanism as shown in Fig. 103. The contact maker consists of an exceedingly light steel contact arm, the end of which rests lightly on a hardened steel cam which rotates at one-half crankshaft speed. The other end of the contact arm is grounded permanently to the base through the spring which carries the contact arm. This has an advantage in that there is no pivot which the arm swings on, to wear and otherwise cause

trouble. The normal gap between the breaker points should not be less than .005 in. nor more than .008 in. The standard setting is .006 in. This is about the thickness of two pages of this book.

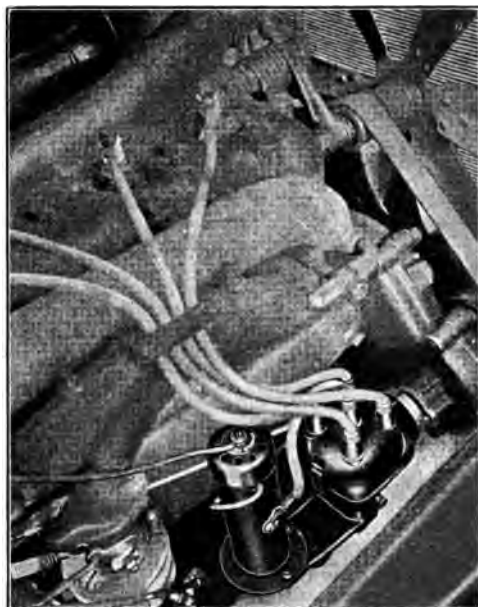

FIG. 102.—Atwater-Kent type CC ignition system mounted on 1918 Maxwell engine.

For use on four-cylinder engines, the cam has four lobes which open the contact points four times for each revolution of the timer shaft or twice for each revolution of the engine crankshaft. Each time the con-



FIG. 103.—Atwater-Kent breaker mechanism, type CC.



FIG. 104.—Construction of Atwater-Kent distributor head, type CC.

tact points are opened, the primary circuit of the ignition system is interrupted, thus producing a discharge of secondary high-tension current at one of the spark plugs. The secondary spark occurs when the contacts separate.

The distributor head, a section of which is shown in Fig. 104, forms the top of the ignition unit. Each spark plug wire terminates in an electrode which passes through the distributor cap. A rotating distributor block takes the high-tension current from the center terminal of the distributor and distributes it to the plugs in the proper firing order. The distributor block just clears the distributor points without actually touching. The high-tension current jumps this small gap without appreciable loss.

In Fig. 105 is shown a complete circuit diagram of the usual type *CC* installation. In some cases, the ignition switch may be combined with the lighting switch. With the switch shown, the primary circuit is

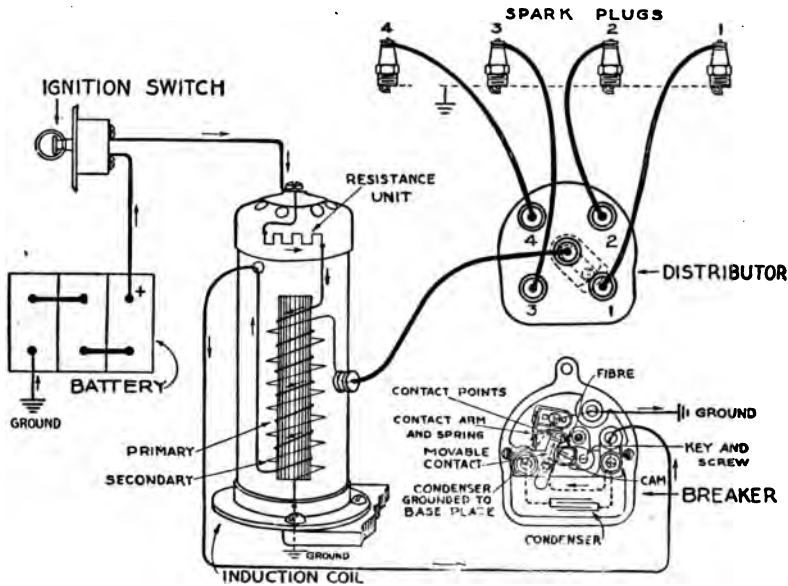

Fig. 105.—Wiring diagram for Atwater-Kent ignition system, type *CC*.

complete when the ignition button is pushed in, the arrows indicating the path of the current. A resistance unit is mounted in the top of the coil housing to provide protection for the coil and battery in case the switch is left on. It also assists in equalizing the secondary spark at high and low engine speeds as previously explained.

*The Condenser.*—The condenser is mounted directly on the timer base beside the breaker, the electrical connections to the breaker contacts being as shown in Fig. 105. The method of condenser installation is shown in Fig. 106. The condenser has two flat copper terminals which are clamped under the screws which hold the condenser cover in place. In installing the condenser, one copper terminal *A* should be clamped under the insulating washer 3 so as to force it in contact with the bright

metal surface of the timer base plate thus grounding terminal *A*. The other terminal *B* is forced against the upper condenser cover plate 4 on the side adjacent to the breaker connection screw. This cover plate is insulated from the base plate; consequently, terminal *B* is insulated from the ground and makes electrical connection with the adjustable contact 7.

The sequence of operations in installing the condenser is as follows:

1. Insulated washer placed in position.
2. Condenser placed in pocket.
3. Insulated washer No. 3 is laid on top of condenser terminal.
4. Condenser cover No. 4 placed in position.
5. Insulated screws put in.

Note that contact adjustment is corrected; that is, the points meet squarely and open a maximum distance of .006 in. to .008 in.

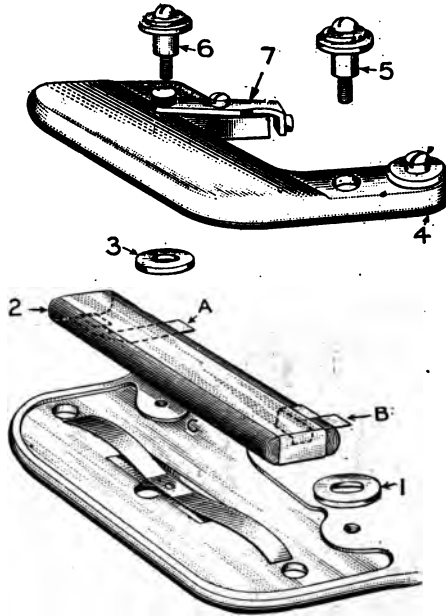

FIG. 106.—Installation of Atwater-Kent condenser, type CC.

*Timing.*—The method of timing the ignition unit with the engine is practically the same for four-, six-, or eight-cylinder engines since by timing the spark in one cylinder the rest will be in proper time. The following procedure should be followed in timing a four-cylinder automobile engine equipped with Atwater-Kent ignition, type *CC*, such as used on the Maxwell models 1917 to 1920 in which the ignition unit is driven by a slotted coupling as shown in Fig. 107.

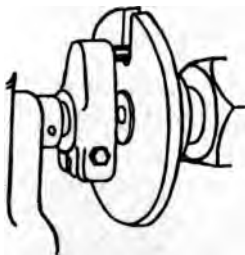

FIG. 107.—Atwater-Kent ignition unit drive coupling.

After making sure that all the advance rods and electrical connections are complete, and that the advance rods are so adjusted as to allow a full movement of the breaker head for the full movement of the advance lever, proceed as follows:

1. After all ignition wiring is complete, including the connections to the plugs, as in Fig. 105, remove all plugs and lay them in order on the top of the cylinder casting, leaving the plug wires attached. Make sure that the terminal ends of the spark plugs do not touch the engine frame.

2. With the ignition switch "ON," crank the engine slowly by hand and note that each spark plug sparks in its proper order (1, 3, 4, 2 for Maxwell), turning "OFF" the ignition when this is checked.

3. Set the spark lever on the steering wheel about  $1\frac{1}{4}$  in. from "full retard" position.

4. Loosen the ignition timer coupling so that the collar on the horizontal shaft, Fig. 107, may be easily turned.

5. Crank the engine slowly by hand until the piston in No. 1 cylinder is on upper dead center firing position. In this position the notch in the drive-shaft half of the coupling should be up.

6. Turn the ignition switch "ON."

7. With the fingers or with the point of a screwdriver turn the collar to the right slowly and carefully until a spark jumps across No. 1 plug as it lays exposed on the cylinder, stopping



Fig. 108.—Connecticut igniter, model 16C.



Fig. 109.—Connecticut coil showing spark gap and connections.

at the instant the spark occurs. In case it should be turned past the correct point, give the collar a quarter turn back and try it slowly and carefully again until it is stopped at the right point.

8. Lock the adjustment by tightening the hexagonal screw on the coupling clamp, and screw the spark plugs into place.

The engine is now timed so that the spark occurs with No. 1 cylinder on dead center when the spark lever is within  $1\frac{1}{4}$  in. of "full retard." This will allow about  $10^\circ$  retard for safe starting and smooth idling and about  $20^\circ$  advance for high speeds.

**73. The Connecticut Battery Ignition System.**—The principal parts of the Connecticut battery ignition system consist of an *igniter*, Fig. 108, a *non-vibrating induction coil*, Fig. 109, and a *switch* of special construction, typical examples of which are shown in Fig. 110 and Fig. 111.

The *igniter*, details of which are shown in Fig. 112 and Fig. 113, operates on the closed circuit principle, the primary circuit being interrupted or broken, and the secondary spark produced when the lobes of the cam strike the roller of the contact arm, separating the contact



FIG. 110.—Front and rear views of Connecticut combination lighting and ignition switch, type H-ND.

points. The cam has as many lobes as there are cylinders and rotates at one-half crankshaft speed. The distributor arm, which directs the secondary current to the various plugs in their proper order of firing, is

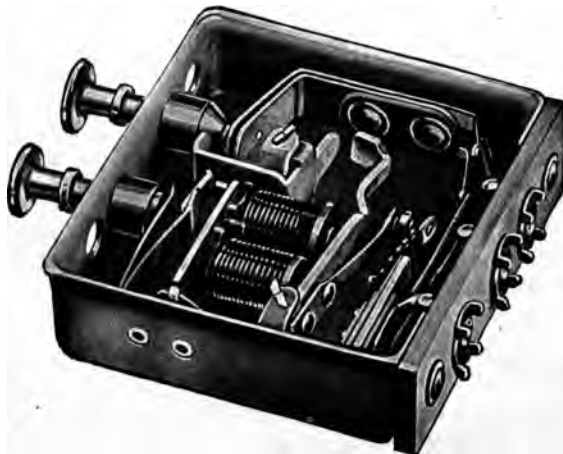

FIG. 111.—Internal view of Connecticut automatic ignition switch, type H.

carried above the cam on the upper end of the same shaft. In most installations, the igniter is mounted on the side of the engine and is driven through spiral gears from one end of the generator shaft.

The *coil*, which also houses the condenser, is mounted close to the



igniter on the engine frame, or on top of the generator, and is connected to the breaker by short flexible leads. One side of the condenser, as well as one side of the primary and secondary winding, is grounded through

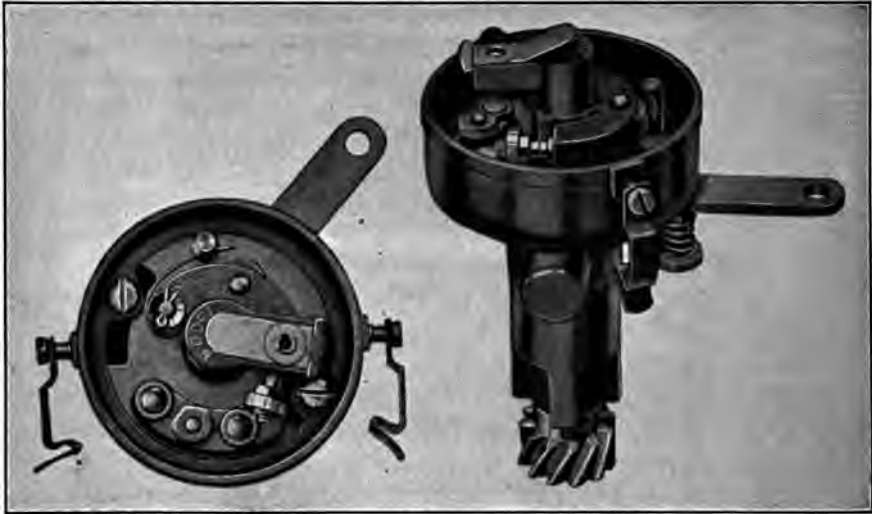

FIG. 112.—Connecticut igniter with distributor head removed showing breaker mechanism, models 16 and 16C.

the brass strip on the side of the coil to the coil base and engine frame. The condenser, although mounted in the coil, is connected electrically

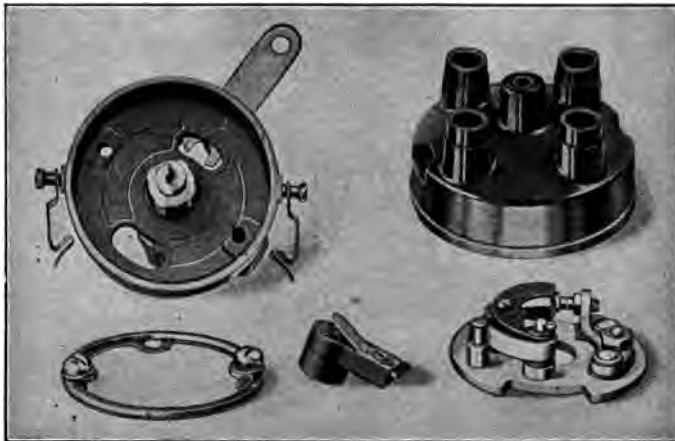

FIG. 113.—Connecticut igniter with distributor head removed showing breaker mechanism, models 16 and 16C.

across the interrupter points through the two short leads which connect the coil with the igniter. Its purpose is to protect the points against pitting as previously explained.

One of the distinct features of the Connecticut ignition system is the switch which is provided with an automatic "kick out" mechanism for releasing the switch and thus opening the primary battery circuit in case the switch should be accidentally left on with the engine not running. The purpose of this is to safeguard against undue draining of the battery and to prevent overheating of the ignition coil.

The switch is made in two principal models known as type *H*, Fig. 111, and type *K*, Fig. 114, the latter being of the latest design as introduced on many 1919 and 1920 cars. When the switch is mounted integral with the lighting switch, the complete switch unit or panel is known as type *H-ND* and *KVD*, respectively, as shown in Fig. 110 and Fig. 115.

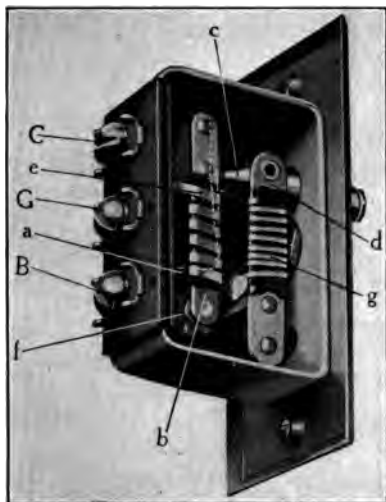

FIG. 114.—Connecticut automatic ignition switch, type K.

A complete circuit diagram of the Connecticut system using the type *H-ND* switch is shown in Fig. 116. When the ignition button (the left-



FIG. 115.—Rear view of Connecticut combination ignition and lighting switch, type KVD.

hand button to the driver) is pushed in, the primary current from the battery completes its circuit as indicated. The current flows from the positive battery terminal to the switch terminal *B*, then through the switch contacts and resistance element to the switch terminal *C* which is connected to the terminal *C* on the ignition coil. The current then flows through the primary winding of the coil to the stationary side of the igniter, across the breaker points to the grounded terminal of the coil, returning to the negative terminal of the battery through the ground. The current induced in the secondary winding of the coil, upon interruption of the primary, flows from the secondary winding to the center of the distributor, through the distributor arm to the spark plug, across the plug, and back to the grounded coil terminal. It will be noted that a safety gap is provided in the top end of the coil. It is enclosed in a mica

tube inaccessible to vapor or fumes yet is under a mica window so that the spark may be readily observed in the case of a misfiring cylinder. The purpose of this gap, as previously explained, is to protect the secondary winding from the destructive action of the high voltage, in case a plug terminal should become disconnected and the high-tension current thus prevented from taking its regular path. The ignition is turned off by simply pushing in on the "OFF" button, which will release latch *G* allowing the "ON" button to fly out and the switch contacts to open.

*Operation of Automatic Switch, Type H.*—A study of Fig. 116 will also show the principle of the automatic switch mechanism. The thermostat consists of two strips of dissimilar metals, nickel steel and spring brass, welded along their entire surface and wound with a heating element similar to that used for resistance units. Brass expands with increase

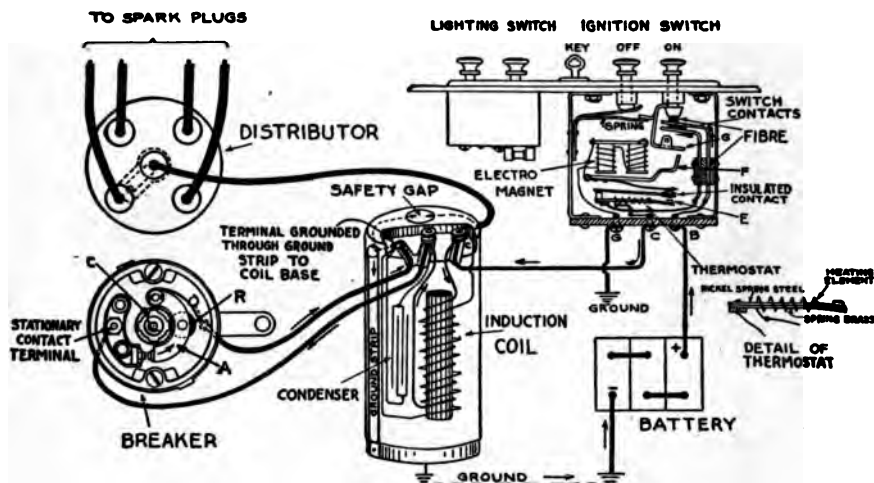

Fig. 116.—Wiring diagram of Connecticut battery ignition system, wiring type H ignition switch.

in temperature much more rapidly than nickel steel; consequently, the thermostat blade, which is fixed at one end, will bend as it is heated up in proportion to the increase in temperature. The resistance unit is in the primary ignition circuit.

In case the switch is left on with the engine not running and the breaker points closed, the continuous flow of current through the resistance unit will cause the thermostat blade to heat up and bend sufficiently to close the contacts *E*. This will complete a circuit from the battery through the winding of the electromagnet causing the arm *F* to vibrate rapidly. The end of arm *F* upon striking the lever *G*, automatically releases the switch button. The thermostat can be adjusted to operate at any time from 30 seconds to 4 minutes. This adjustment is made after the engine stops by varying the gap of the thermostat contacts. The nor

mal setting should be such as to release the switch in about three-quarters of a minute after the engine has stopped.

*Operation of Automatic Switch, Type K.*—The automatic switch, type *K*, differs from type *H*, principally in the arrangement of the thermostats, two being employed instead of one, and in the method of releasing the switch button, as may be seen by comparing Fig. 111 and Fig. 114. A circuit diagram of a typical ignition system using the type *K* switch is shown in Fig. 117. Referring to Fig. 114 and Fig. 117, the operation of this switch is as follows: With the switch button plunger *c* pushed in, the contacts *h* are closed and the primary circuit is completed through the thermostatic bar *b* and heater tape *e*, the current entering the switch at

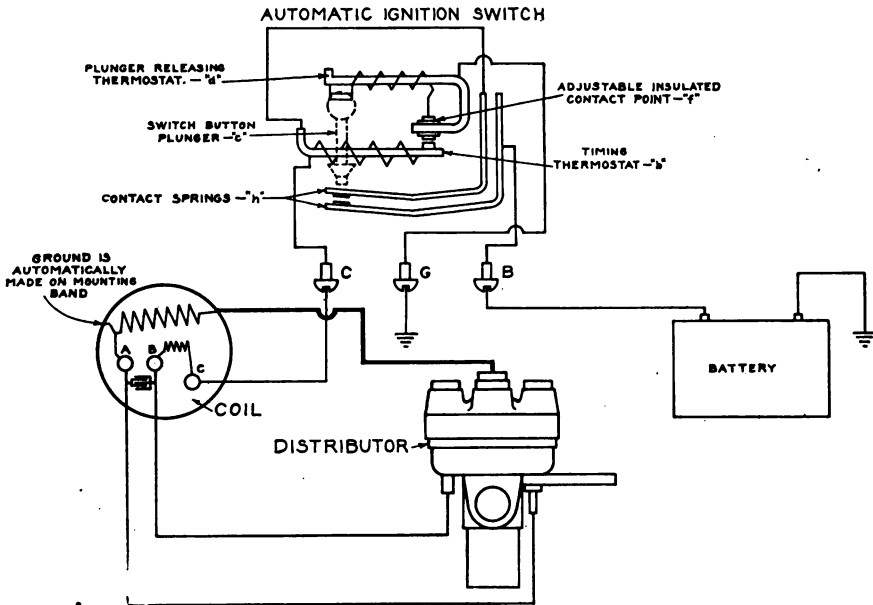

FIG. 117.—Wiring diagram of Connecticut battery ignition switch using type *K* switch.

terminal *B* and leaving at terminal *C* as indicated. The switch button is held in by a fiber wedge-shaped block mounted on the free end of a second thermostatic bar *d* the fixed end of which is grounded to the switch case and electrically connected to terminal *G* which is also grounded. If the switch is left on and an uninterrupted flow of current is allowed to pass through the heater tape *e*, the thermostatic bar *b* will bend down until it makes contact on adjustment screw *f*. This will allow current to flow from the battery through the heater tape *g* to the ground post *G* causing the thermostatic latch *d* to bend up sufficiently to release the switch button plunger *c*, thus opening the switch contacts *h*. The switch can be also turned off by pulling plunger *c* which will release the latch and accomplish the same result.

The time in which the switch will release itself after the engine has stopped may be regulated by turning the adjustment screw *f*. The time for release may be increased by increasing the gap between the contacts slightly, and the time decreased by decreasing the gap slightly. The normal adjustment should be such that release of the switch will occur in about three-fourths of a minute, the same as for the switch type *H*.

The breaker mechanism is very simple as Fig. 116 shows. In operation, the rotation of the cam *C* causes it to strike the fiber roller *R* thus lifting the arm *A* and separating the contact points. The arm is returned to its normal position by a flat spring attached to the contact arm.

The breaker mechanism is mounted on a plate which rests in the casing and is held in place by a spring ring and also by a solid ring, the latter being held by two screws as shown in Fig. 113. The advance lever engages a pin on the breaker plate, the whole plate being advanced around the shaft to advance the time of ignition. The contacts should be adjusted to open .020 in.



FIG. 118.—Remy battery ignition breaker and distributor unit.

Inasmuch as the system operates on the closed circuit principle, the maximum time is allowed for the complete magnetization of the induction coil. The intensity of the sparks produced at the plugs depends upon this magnetization. It follows that the slower the speed of the engine the greater the magnetization of the core and the greater the spark intensity. However, this is partly counteracted by the action of the resistance unit surrounding the thermostat. This resistance unit tends to equalize the intensity of the secondary spark at high and low engine

speeds in the same way as the resistance units on other systems.

**74. The Remy Ignition System.**—The Remy battery ignition system, which is of the high-tension distributor type, consists principally of a vertical breaker unit, Fig. 118; a non-vibrating coil, a typical design of which is shown in Fig. 119; and a switch which may be of either the plain or polarity changing type. The ignition switch is often combined with the lighting switch.

One type of Remy ignition system which has been used very extensively is that shown in Fig. 120. In this system the breaker is driven from the generator shaft through spiral gears and the coil is mounted close by on the generator frame. The coil is supported by a special bracket which also serves to ground one side of both the primary and the secondary windings. The breaker operates on the closed circuit principle and is very simple in construction as may be seen from Fig. 121.

interrupter comprises two contact points of platinum-iridium or steel, usually the latter, one being stationary while the other is fixed at the free end of a pivoted lever which bears against the rotating cam. The cam has accurately ground corners (one for each cylinder) which bear against the fiber block on the lever in rotation and cause



FIG. 119.—Remy induction coil—two primary terminal type.

contact points to open and close at correct intervals. The cam has as many lobes as the engine has cylinders and is, therefore, driven at one-crankshaft speed. The high-tension current is distributed to the spark plug leads by a distributor brush which is carried above the cam so that it does not touch the pins in the distributor head.

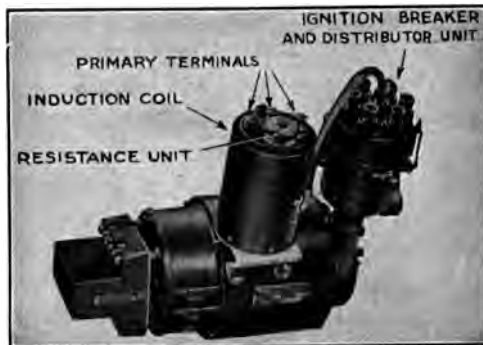

FIG. 120.—Remy generator with ignition coil and distributor mounted.

The distributor brush in some models also carries the *safety gap* which is a gap of  $\frac{3}{8}$  in. between the distributing segment and the bottom plate which is grounded upon the shaft. This provides a safety gap across which the spark can discharge in case any of the connections from the distributor to the spark plug should become broken. The destruction of the

coil windings due to excessive voltage is thus prevented. The safety gap should not be less than  $1\frac{1}{32}$  in. as the spark might then discharge across it instead of across the spark plug gap when the plug is under compression. Some of the distributor units are equipped with an automatic spark advance in which case the governor mechanism is mounted in the housing below the cam. The advance of the spark is provided by the



FIG. 121.—Remy breaker and distributor.

revolving weights which spread more and more due to centrifugal force and shift the cam in an advance direction. As the engine slows down, the cam is shifted in the reverse direction and the spark is retarded.

Two types of coils are used. One has two primary terminals on top, as shown in Fig. 119, in which case the coil operates with a simple switch of the "ON" and "OFF" type, while the other has three primary termi-

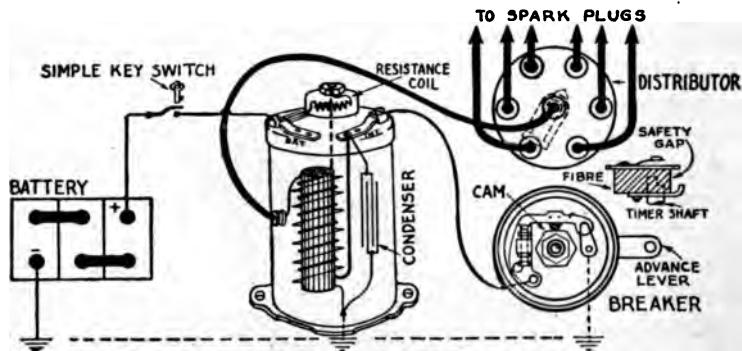

FIG. 122.—Wiring diagram for Remy battery ignition system using two primary terminal coil.

nals on top as shown in Fig. 120 and operates with a four-terminal switch of the polarity changing type. In both cases the condenser is placed inside the coil and a resistance unit is mounted on top for controlling the primary current. Figure 122 shows a typical wiring diagram of the Remy system using the two-terminal coil, and Fig. 123 shows a typical wiring diagram of the system using the three-terminal coil.

The purpose of the polarity changing type switch is to reverse the direction of current flow across the breaker points each time the ignition is used. It is absolutely necessary that the ignition switch be placed in the "OFF" position when the engine is not running. If it is left in the "ON" position, current from the storage battery will discharge through the ignition coil. If this discharge continues, the battery will be ex-

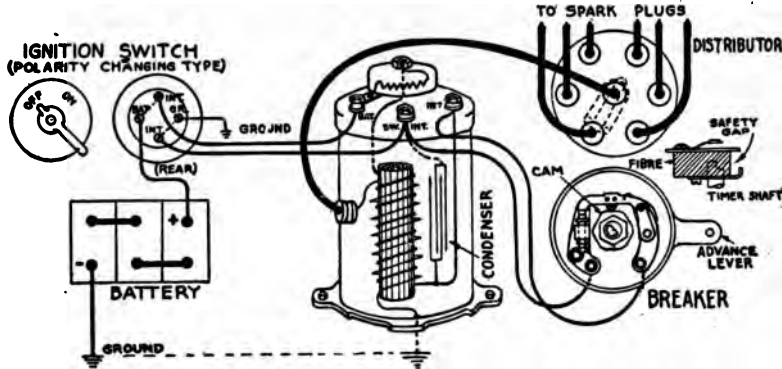

FIG. 123.—Wiring diagram for Remy battery ignition system using three primary terminal coil.

hausted. To aid in preventing theft or unauthorized use, the operator should remove the switch key when leaving the car.

*Adjustment of Contact Points.*—The contact points should have a maximum opening of .020 in. to .025 in., or the thickness of the gage which is on the side of the wrench furnished for adjusting the contact point opening. It is recommended that an inspection of the points be made every 1000 miles. If the points are found to be worn unevenly or are dirty, they may be cleaned by passing a fine flat file, or preferably a piece of No. 00 sandpaper, between them. When the contacts are properly fitted, they should make clean square contact as shown by A in Fig. 124. Adjustment of the gap between the contacts is made by loosening the lock nut with the wrench furnished, turning the adjusting screw, and then locking the nut again. *These contact points should not be oiled.* A slight trace of vaseline placed on the fiber block or on the cam every 1000 miles will keep the cam from rusting.

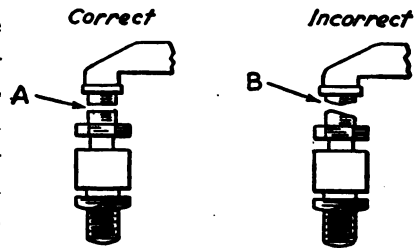

FIG. 124.—Correct and incorrect shapes for battery breaker contact points.

*Timing Ignition to the Engine.*—The time of opening the breaker contact points relative to the travel of the piston is determined as follows: The distributor advance lever is pushed back to full retard position. The



engine is brought to *dead center* position with No. 1 piston at the top of its compression stroke. Dead center is accurately indicated when the line *U. D. C.* on the flywheel is opposite the corresponding prick-punch mark on the engine frame. In this position of the flywheel the pistons in both of the two cylinders indicated by the numerals after *U. D. C.* will be at the top of the stroke. By holding the finger over the open pet-cock as the engine is turned in the proper direction of rotation the cylinder on compression can be determined. The breaker contact points should just be starting to separate (the flywheel being turned in the direction of rotation past dead center position) for a six-cylinder engine, or from 1 in. to  $1\frac{3}{4}$  in. (as measured on the flywheel) past dead center for a four-cylinder engine.

If it is found necessary to readjust the timing, the distributor arm (which has an arrow on it) should be removed and the nut which holds the cam in place unscrewed. The cam can be loosened by giving it a sharp rap to release it from the taper part of the shaft on which it fits snugly. It should be turned to obtain the proper time of opening the contact points, noting that it strikes the fiber in the proper direction of rotation. The cam is then rapped down in place and the nut tightened to keep the cam from slipping.

*Oiling.*—The grease cup below the distributor head should be kept full of medium grease, and should be given two turns to the right every 500 miles, so as to force a little grease into the bearings.

*Spark Plugs.*—Failure of spark is sometimes due to the spark plug gap inside the cylinder becoming clogged with carbon or oil. This gap should measure .025 in. to .030 in., or the thickness of the gage supplied by the manufacturer.

**75. The Remy-Liberty Ignition Breaker for U. S. Military Truck, Class B.**—The special battery ignition breaker manufactured by the Remy Electric Company for the U. S. military truck, Class B, is shown in Fig. 125 and Fig. 126. The breaker is of the closed circuit type and operates with a plain non-vibrating coil. Both breaker and coil are mounted on the left side of the engine in front of the water pump. The coil is designed so that a resistance unit is not used in the primary circuit. The condenser is mounted inside the distributor head where it is very accessible. Another feature is that the breaker mechanism is mounted on a plate separate from the main distributor body. This permits the advancing and retarding of the spark by simply shifting the breaker mechanism around the cam instead of shifting the entire head, thus avoiding the bending of the wiring. The operation and adjustment of the system are identical with other systems of the closed circuit type.

**76. The North East Battery Ignition System.**—The installation and wiring of the North East battery ignition system as used on the Dodge car is shown in Fig. 89. The ignition unit, Fig. 127, is virtually a magneto

replacement outfit, being driven the same as a magneto. This unit comprises an *induction coil*, a *breaker* of the closed circuit type, a *condenser* mounted in the breaker housing, and an *automatic spark advance mech-*



Fig. 125.—Remy-Liberty battery ignition unit for U. S. Military truck, Class B.

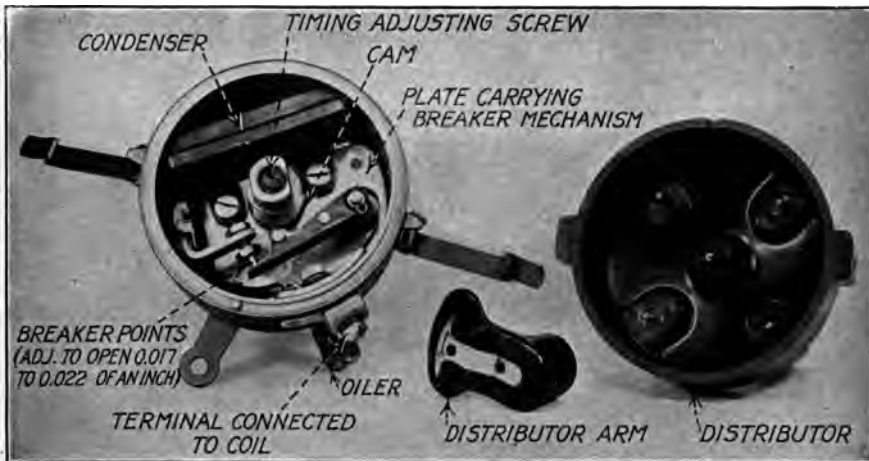

Fig. 126.—Construction of Remy-Liberty battery ignition unit for U. S. Military truck, Class B.

*anism* which is shown separately in Fig. 128. Either one of two types of breaker is used. In one type, the terminals of the breaker are both insulated and the system operates with a polarity changing type switch.

In the other type, Fig. 129, one breaker terminal is grounded and the system operates with a simple key switch.



FIG. 127.—North East ignition unit.



FIG. 128.—North East automatic spark advance mechanism.

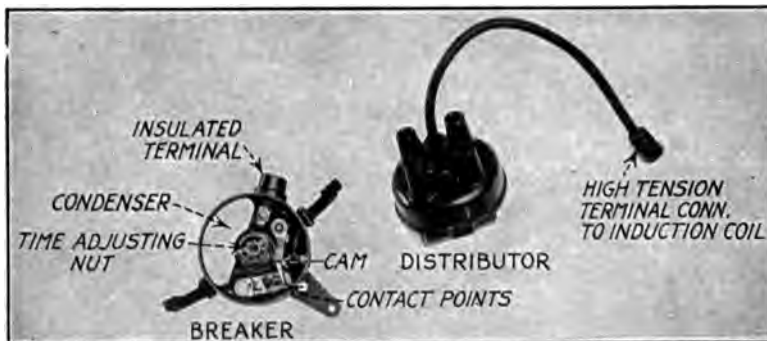

FIG. 129.—North East breaker and distributor.

The principle of the system, as well as the method of ignition timing, is very similar to that in other systems of the closed circuit type. To time ignition the cam is loosened and the time of contact break is adjusted by shifting the cam so that the points are on the verge of separating when

the cam is being turned forward with No. 1 piston about  $\frac{1}{8}$  in. below upper dead center position on the working stroke.

A good way to check the time of contact break is with a test lamp, connected as shown in Fig. 130. After the ignition switch is turned on, the engine should be turned over slowly by hand. The light will flash on and off depending upon whether the contacts are open or closed. The instant the points separate, the lamp will light. The light should occur (with the above setting) when the dead center mark on the fly-wheel is  $\frac{1}{2}$  in. to  $\frac{3}{4}$  in. past dead center position. The time of contact opening should be the same for each cylinder. The points should be adjusted to separate .020 in.

**77. The Delco Ignition System.**—A few of the many types of Delco ignition equipment in use are shown in Fig. 131 and Fig. 132. The varied designs are due not so much to the principle involved, as this is practically the same in all models, but to the many individual igni-

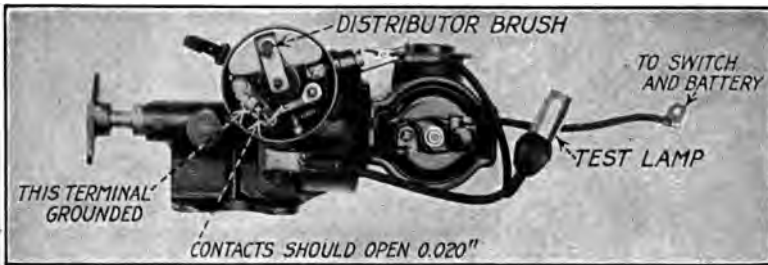

FIG. 130.—Method of connecting test lamp to check time of contact opening.

tion requirements of the four-, six-, eight-, or twelve-cylinder engine on which they are used.

The distributor and breaker unit are carried on the front end of the generator and are driven at one-half crankshaft speed by the same shaft which drives the generator. The distributor consists of a cap or head of insulating material with one high-tension contact in the center and as many similar contacts as there are cylinders spaced equidistant about the center. The distributor arm or rotor carries a contact button which makes continuous contact with the head and serves to direct the secondary current to the proper spark plug.

Beneath the distributor head and the rotor is the breaker, Fig. 133, which is provided with a screw in the center of the shaft. The loosening of this screw allows the cam to be turned in either direction to secure the proper timing. The breaker operates on the closed circuit principle, and the spark occurs at the instant the timer contacts open. The adjustment screw must always be screwed down tight after the cam is adjusted.

The distributor is equipped with both manual and automatic con-

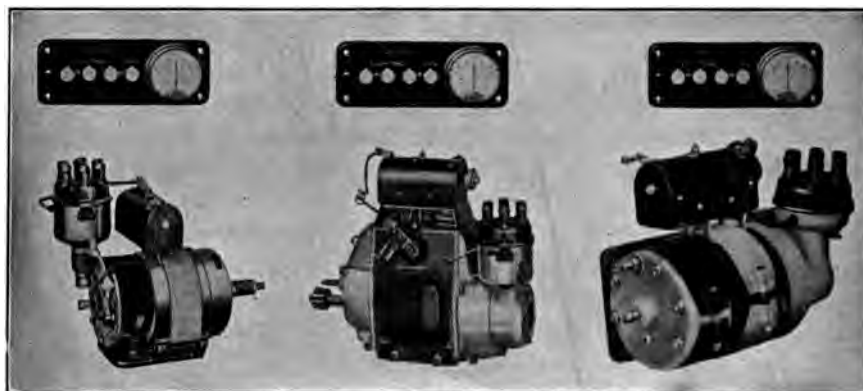

OLDSMOBILE.

AUSTIN.

PATTERSON.

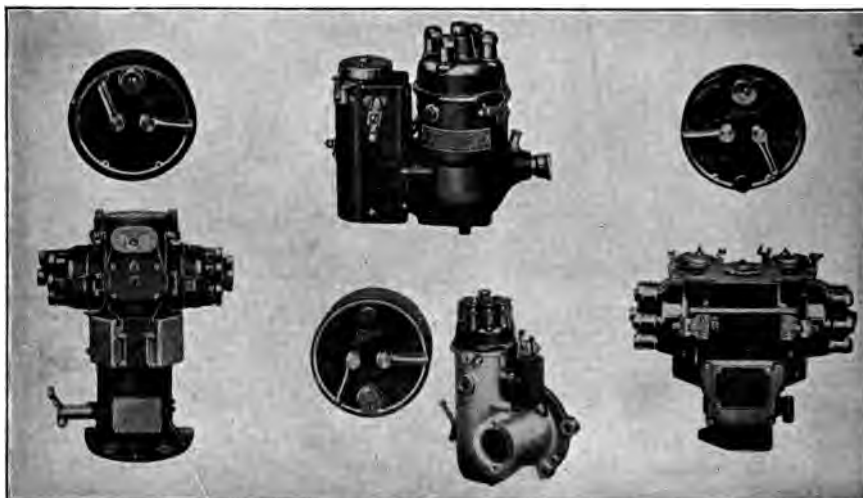

PACKARD.

CADILLAC.

NATIONAL.

FIG. 131.—Types of Delco ignition equipment.



FIG. 132.—Typical 1920 Delco ignition type generators.

trol. The manual control is linked up with the spark lever on the steering wheel sector. This is for the purpose of securing the proper retard of the ignition for the starting operation and very slow idling speeds, and to secure the proper advance required for maximum power at very low engine speeds over which the automatic feature has no control.

The automatic spark advance mechanism is located in the lower part of the breaker housing. This mechanism is for the purpose of securing the additional advance that is required to give the best operating conditions of the engine at the higher engine speeds. This feature makes it unnecessary to manipulate the spark lever for varying engine speeds in order to secure the best performance of the engine.

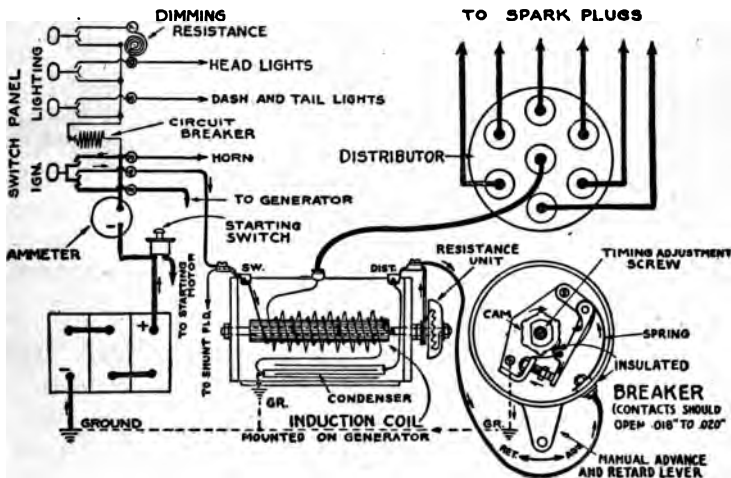

Fig. 133.—Wiring diagram for typical Delco ignition system.

The ignition coil is mounted on top of the generator as shown in Fig. 132. It will be noticed from Fig. 133 that an *ignition resistance unit* is mounted on one end and that the condenser is placed in the bottom of the coil with one side grounded. The switch button next to the ammeter, Fig. 131 and Fig. 132, controls both the ignition circuit and the circuit between the generator and the storage battery. It connects the three contacts numbered 2, 4, and 3 in the wiring diagram, Fig. 133. The second button from the ammeter controls the cowl and tail light; the third button controls the headlight dim; and the button on the extreme left controls the headlight bright.

**78. The Westinghouse Ignition Systems.**—The Westinghouse Vertical Ignition System is characterized mainly by the fact that the interrupter, condenser, distributor, and induction coil are all contained in a single unit known as the Westinghouse Vertical Igni-

tion Unit. This ignition unit is sometimes mounted independently, but it is generally mounted on the generator as shown in Fig. 134.

The construction of the unit is clearly shown in Fig. 135 which shows the interrupter at the bottom of the assembly with the condenser connected directly across the contact points. This close association of the contact points and the condenser gives a more positive condenser

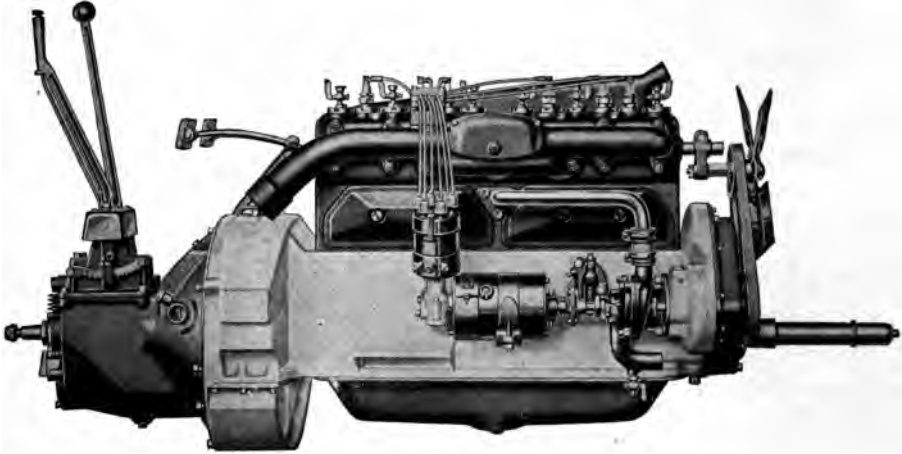

FIG. 134.—Westinghouse vertical ignition unit mounted on an automobile engine.

action and a better operation of the ignition system than when the contact points and the condenser are widely separated. Immediately above the interrupter is the induction coil containing the primary and secondary windings. At the top of the unit is the distributor. The distributor arm is driven by a shaft which extends upward from

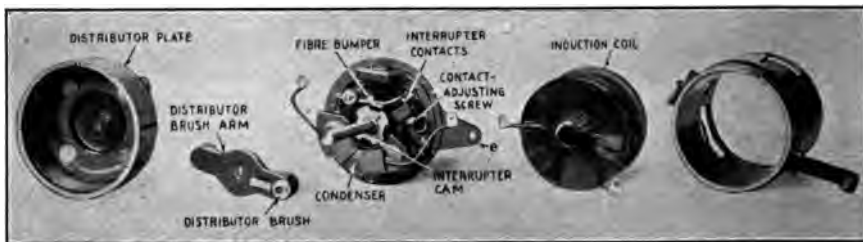

FIG. 135.—Parts of Westinghouse vertical ignition unit.

the interrupter through the hollow core of the induction coil. This arrangement gives a very compact ignition system as most of the required parts are located in one unit. The only parts of the circuit that are outside of this unit are the battery, ignition switch, and ballast resistor. The ballast resistor is mounted on the back of the ignition switch, Fig. 136 and Fig. 137. The ignition switch is double pole

and is so arranged that the current passes through the breaker points in a different direction every time the switch is turned on. This re-



FIG. 136.—Front view, Westinghouse ignition switch.



FIG. 137.—Rear view, Westinghouse ignition switch with resistor ballast mounted in place.

versal of current through the breaker points prevents them from pitting away unevenly and lengthens their life.

The ballast resistor, which is an integral part of the primary circuit, consists of a resistance unit having a high temperature coefficient. It is placed in series with the primary of the induction coil and all current flowing through the primary circuit must pass through this resistor. If the ignition switch should be left on with the engine idle, the uninterrupted current would heat the resistor, thus increasing its resistance and cutting down the amount of current to such a low value that the coil would not be burned out.

When the engine is running, a certain amount of current will flow through the primary circuit at each closing of the contacts. With an increase in engine speed, the time of contact is shortened and the time allowed the primary current to build up is materially reduced. As the period of current flow is reduced in length, the resistor cools, its resistance is lowered, and the value of the current in amperes

that passes is increased, allowing the current in the primary coil to build up very rapidly. Under this regulation, a small current is produced in the primary circuit at low engine speeds, and a large current at high engine speeds, while the magnitude of the spark produced by the sec-

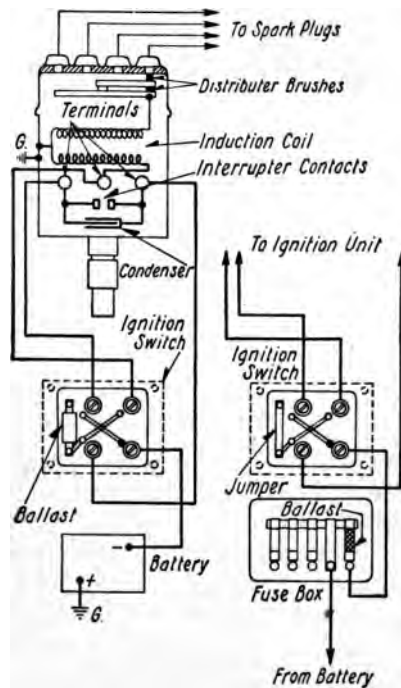

FIG. 138.—Wiring diagram for Westinghouse vertical ignition system.



ondary winding is uniform at all engine speeds. The wiring diagram of the vertical unit ignition system is shown in Fig. 138.



FIG. 139.—Westinghouse type SC ignition coil.



FIG. 140.—Westinghouse type SC distributor for an eight-cylinder engine.

*The Westinghouse Type SC Ignition System.*—A later model Westinghouse ignition system is the type SC which uses a coil separate from the

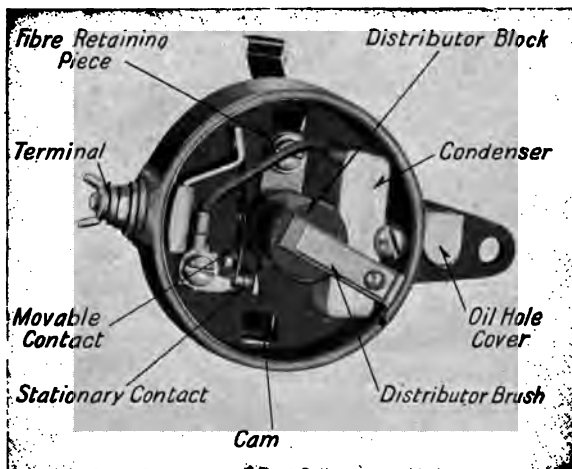

FIG. 141.—Interior of Westinghouse Type SC interrupter.

distributor unit. This coil, shown in Fig. 139, is tubular in shape and is mounted upon a metal base plate which facilitates its installation at

by convenient place either on the engine or on the dash. The ballast resistor is carried in a groove around the porcelain cap instead of being mounted on the ignition switch as in the Vertical Unit.

The distributor unit for an eight-cylinder engine is shown in Fig. 140. The distributor unit carries but one low-tension binding post since the high-tension current is grounded in the interrupter. Figure 141 shows the interior construction of the interrupter. The movable contact point is mounted upon a steel spring which flexes under the action of the interrupter cam, thus opening the circuit at the contact points. The condenser is contained in the interrupter housing and is in electrical contact with the moving contact point. The stationary contact is grounded directly to the metal housing as is also one terminal of the condenser. This puts the condenser in parallel with the breaker points.

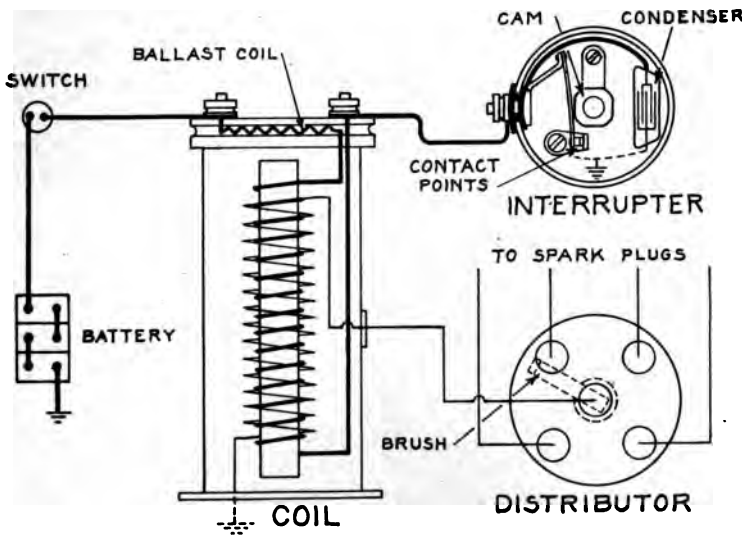

Fig. 142.—Wiring diagram, Westinghouse type SC ignition system.

The wiring diagram of the type SC system is shown in Fig. 142. The primary winding of the coil has two terminals located on the top of the coil, and the secondary winding has one terminal on the side, the other end of the secondary winding being grounded on the base plate of the coil. If this coil be mounted on an insulating support, such as the wooden sh of an automobile, a wire should be run from one of the screws or nuts holding the coil in place to some convenient nut or bolt on the metal work of the engine. A simple two-point switch is used for the ignition control.

**79. The Philbrin Ignition System.**—The Philbrin ignition system provides a combination of the single spark and the high frequency vibrator coil continuous spark systems. This combination is effected by a

special type switch. With the Philbrin system the driver has the option of using a single spark system, especially adapted for driving at ordinary touring speed after the motor has been warmed up; or a high frequency

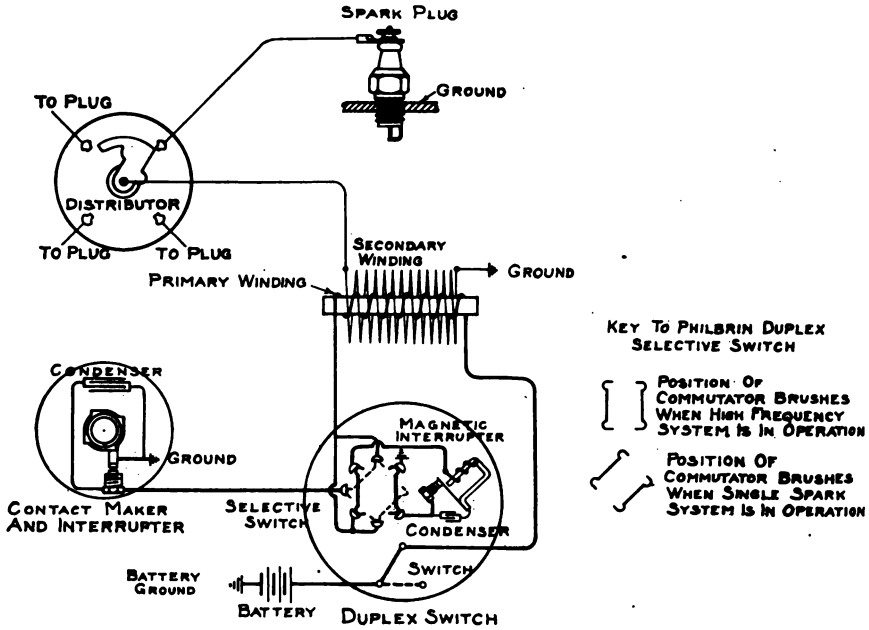

FIG. 143.—Wiring diagram, Philbrin Duplex ignition system.

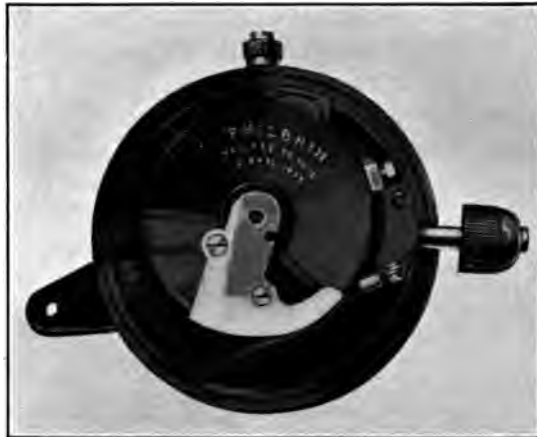

FIG. 144.—Philbrin distributor.

spark system adapted for slow driving through crowded traffic or when the engine is cold.

That a clear understanding of the operation may be had, the high frequency system, the one to be used for starting a cold motor in

winter, will be considered first. Figure 143 is the wiring diagram of the Philbrin ignition system. With the selective switch in the position shown by the heavy solid lines the path of the current through the circuit is as follows: From battery to primary winding on coil, to selective



FIG. 145.—Interior of Philbrin Duplex switch.

switch, to vibrating coil winding through vibrating points, to ground. The contact maker or interrupter is not included in this circuit; consequently, the vibrator is working continuously, producing a steady stream

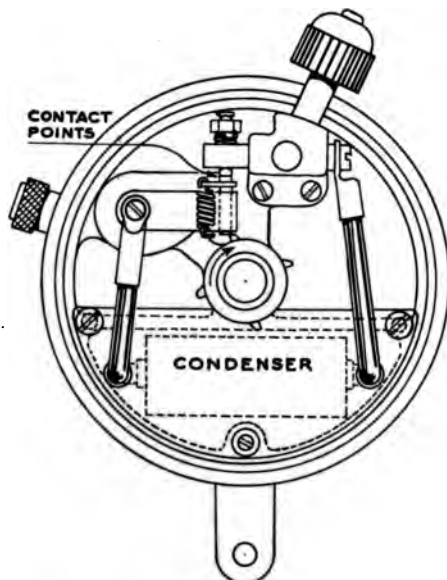

FIG. 146.—Philbrin contact maker.

of sparks in the secondary circuit. This stream of sparks is distributed to the proper cylinder by the distributor, Fig. 144. In this case, the distributor acts as a timer for the high-tension circuit. The continuous stream of high frequency sparks produced under this operation permits



FIG. 147.—Philbrin distributor and contact maker for an eight-cylinder engine.



FIG. 148.—Philbrin waterproof coil.



FIG. 149.—Philbrin distributor unit for twelve-cylinder engine, with coil mounted on base.

a cold motor to be started easily, or allows the driver to throttle down the engine and drive slowly in crowded traffic.

Figure 145 shows the interior construction of the switch used by Philbrin. It carries a high frequency vibrator with a condenser connected across its points.

By turning the selective switch to the position shown by the dotted lines in Fig. 143, the system will operate on a single spark. The high frequency vibrator is now cut out of the circuit and the contact maker or interrupter, Fig. 146, is introduced in its place. The contact maker is of special form, designed to give a very short closed circuit period with a quick break, and carries a condenser connected across the points. On single spark operation, the system gives but a single spark in each cylinder

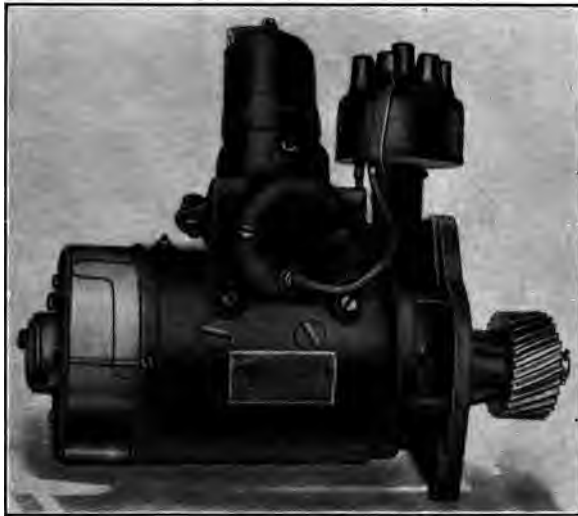

FIG. 149a.—Wagner ignition system mounted on generator.

at the proper firing time. The assembled contact maker and distributor for an eight-cylinder motor is shown by Fig. 147. The coil, Fig. 148, is of special waterproof construction, and is usually mounted on the underhood side of the dash, but for some installations the coil, contact maker, and distributor are grouped into a compact unit as shown in Fig. 149.

**80. Wagner Ignition System.**—The Wagner ignition system employs a single non-vibrating coil with a high-tension distributor. The system is usually mounted on the generator, as shown in Fig. 149a, but may also be mounted independently if desired. The units which compose the Wagner system have been designed so as to be water and dust proof, removing many causes of ignition trouble and making the operation of the system more reliable.

The coil shown in Fig. 149b is contained in a pressed steel case which

protects the parts of the coil from mechanical injury and moisture. A resistance unit is mounted on one of the primary terminals near the bot-



FIG. 149b.—Wagner coil.

tom of the coil. The high-tension terminal is at the extreme top of the unit. Immediately below is the safety gap placed inside the case with a



FIG. 149c.—Wagner condenser.

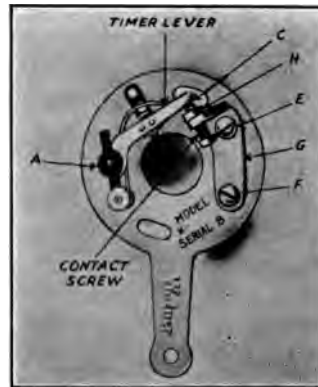

FIG. 149d.—Wagner timer or interrupter.

mica window through which it may be seen. The condenser, Fig. 149c, is contained in a pressed steel case. This construction and method of assembly protect the condenser from moisture, temperature changes, or

mechanical vibrations. The condenser may be mounted either on the distributor housing or on the base of the coil.

The timer or interrupter, Fig. 149*d*, is carried immediately beneath the high-tension distributor in the distributor unit shown in Fig. 149*e*. The distributor disc, Fig. 149*f*, distributes the high-tension current to the various spark plug cables by means of the plate *D*. The plate does not make actual contact with the distributing pins shown in Fig. 149*g*, but passes very close to them with about one ten-thousandths of an inch of



FIG. 149*e*.—Complete Wagner timer distributor.

air gap across which the current jumps. This avoids the use of carbon brushes and does away with cleaning the distributor head.

The interrupter, Fig. 149*d*, provides means for adjusting the contact points. One point is mounted on the end of an adjustable contact screw held in place by the lock nut *H*. After the points have worn until they no longer give the proper opening, which should be about 0.020 in., the lock nut may be loosened and the contact screw turned up until the opening is again correct. The lock nut should then be tightened.

After continued use for a long period the contact points may need replacing. A new timer lever and contact screw will then be required.



The old timer lever and contact screw should be removed and the new parts placed in position. The opening of the contact points should then be adjusted to the proper distance and the lock nut tightened. The points should face each other squarely and should touch throughout their whole surface *C*, Fig. 149*d*. If they do not line up, the screws *E*



FIG. 149*f*.—Wagner distributor disc.



FIG. 149*g*.—Wagner distributing head.

and *F* should be loosened and the support plate *G* moved sufficiently to align the points properly, after which *E* and *F* should be tightened.

The timer lever pivot is lubricated by an oil-soaked wick contained in the hollow spindle under the spring clip *A*, Fig. 149*d*. At the beginning of the season this wick should be given about three drops of thin oil to

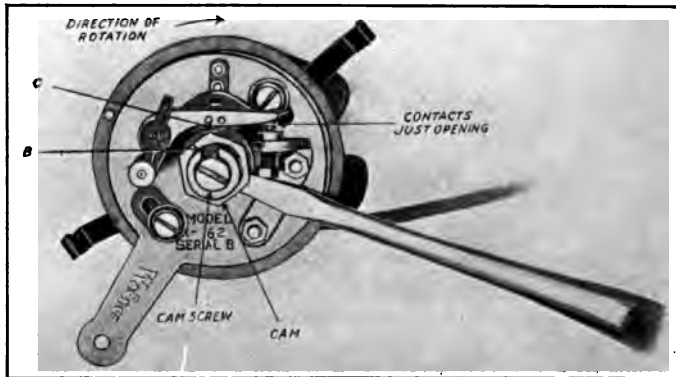

FIG. 149*h*.—Timing the Wagner interrupter.

provide lubrication for the season. The grease cup on the distributor shaft, Fig. 149*e*, should be filled with grease and screwed down one-half turn every 500 miles.

If the setting of the interrupter has been disturbed and it is desired to reset it, the cam screw should first be loosened and the cam raised off

its taper on the shaft by prying it up with a screwdriver as shown in Fig. 149*h*. Cylinder No. 1 should then be set on top dead center of the working stroke and the spark lever retarded to the limit of its travel. The cam then should be rested lightly on the taper of the shaft and turned around in the direction in which it rotates when driven by the engine until the slot *B* is opposite the cam on the timer lever *C*, with the points just opening. The top of the cam should then be tapped lightly with the handle of the screwdriver to force it solidly on to the tapered portion of the shaft and the cam screw tightened. The opening of the contact points should be again checked with the position of the piston to insure that the adjustments have not been disturbed when the cam was tightened. The wiring diagram is shown in Fig. 149*i*.

#### 80a. Timing Battery Ignition with the Engine.—

The details connected with ignition timing depend somewhat on the make and type of ignition system and also on the type of engine. The general principles, however, are the same. The following rules for timing a four-cylinder engine, with minor modifications to suit certain individual conditions, will apply generally to all systems of the closed-circuit type having an adjustable interrupter cam.

Place the spark lever on the steering wheel in the fully retarded position, making sure that the interrupter timer lever is fully retarded and that all play in the connecting mechanism from spark lever to timer has been taken up.

With the pet cocks open or the spark plugs removed, turn the engine over slowly by hand. After noting the firing order, either by testing the order of compression or by watching the operation of the valves, turn the engine until the dead-center mark on the flywheel for No. 1 and 4 cylinders (D. C. 1-4) is about 1 in. past dead-center position with No. 1 cylinder (the cylinder next to the radiator) on the upper end of its compression stroke. (One inch measured on the rim of a 16½ in. flywheel measures off about seven degrees of the crank angle.) In a four-cylinder engine, the exhaust valve in No. 4 cylinder should just be closed with this setting.

Remove the distributor head and loosen the timing adjusting screw or nut in the center of the timer shaft. Turn the breaker cam so that the distributor brush or button will be in the position under No. 1 high-tension terminal when the distributor head is fastened in the proper position.

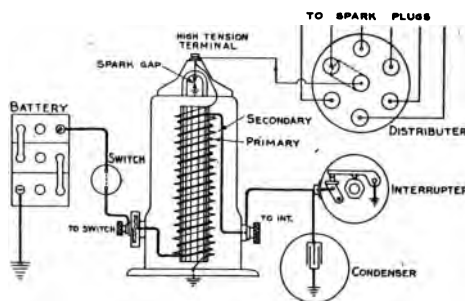

Fig. 149*i*.—Wiring diagram, Wagner ignition system.

In this position, adjust the breaker cam carefully so that when the distributor arm is rocked forward, taking up the slack in the gears, the contacts will be opened by the breaker cam, and, when the arm is rocked backward, the contacts will close.

Tighten the adjustment screw or nut securely and replace the distributor arm and head. The head should be properly located by the locating tongue and the hold-down clips. The distributor should be wired to the plugs in the proper order of firing, beginning with No. 1 and proceeding around the distributor head in the direction of breaker rotation.

**81. Care of Battery Ignition Systems.**—General rules which will provide proper care and insure long life to practically all types and makes of battery ignition systems are as follows:

*Contact Points and Distributor.*—The distributor cap should be removed and the contact points inspected every 1000 to 1500 miles. If found dirty or uneven and pitted, a fine flat file, or preferably a piece of No. 00 sandpaper, should be passed between them. The contact points have a standard opening of .017 in. to .020 inch.

*The Distributor.*—The distributor cap will require no attention except to wipe out from time to time any dust which may accumulate. This may be done by using a rag moistened with gasoline.

*Oiling.*—Each bearing of the breaker distributor unit should be given a few drops of clean cylinder oil every 1000 miles. Oil is much cheaper than new bearings.

Every 1000 to 1500 miles a slight trace of clean oil or grease placed on the fiber block or on the steel cam will keep the cam from rusting. The contact points should not be oiled.

*Wiring.*—Once or twice each season all wiring, especially the high-tension cables, should be thoroughly inspected and all wires with worn or cracked insulation replaced with new. All terminals should be kept tight. Care should be taken that each secondary wire is kept free from oil and well supported so that there is no rubbing contact with the engine frame. Short circuits and misfiring of the engine are thus avoided.

*Spark Plugs.*—Failure of ignition is usually due to dirty spark plugs. When the engine does not fire regularly, the plugs should be examined, and, if found to be sooted, they should be cleaned by scraping off the carbon and washing them in gasoline. The opening of the plug gap should measure .025 in. to .030 in., or the thickness of a worn dime. After the plugs have been replaced in the cylinder, the procelains should be examined to be sure that they are not cracked.

## CHAPTER V

### BATTERY IGNITION SYSTEMS FOR MULTIPLE CYLINDER ENGINES

**82. Firing Order of Four- and Six-cylinder Engines.**—The firing order of a multiple cylinder engine is arranged so as to give an even time distribution of power impulses along the crankshaft. The standard four-cylinder crankshaft has the two center cranks, No. 2 and No. 3, side by side. The end cranks No. 1 and No. 4 are at an angle of  $180^\circ$  from the center cranks as shown in Fig. 150. This arrangement causes the pistons to move in pairs, No. 2 and No. 3 forming one pair and No. 1 and

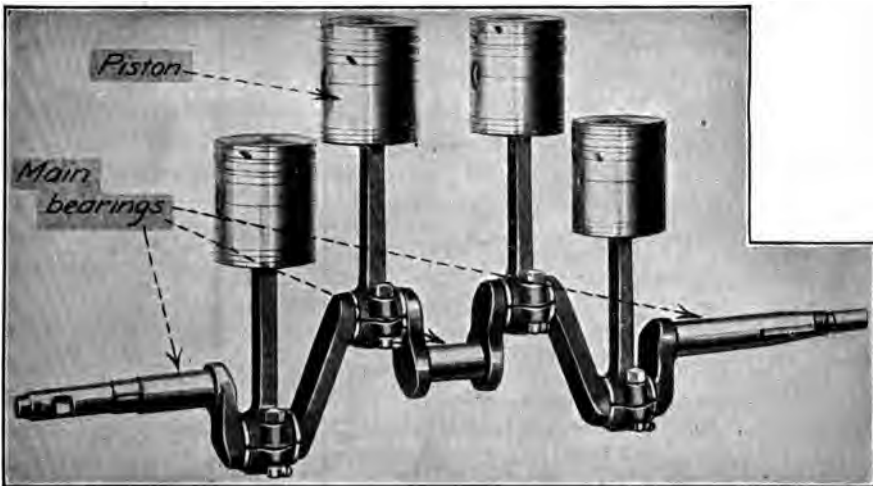

FIG. 150.—Four-cylinder crankshaft.

No. 4 the other pair. When the center pair of pistons is moving up, the end pair is moving down and vice versa, thus giving a smooth running motor without excessive vibration. The No. 1 piston and the No. 4 piston are in the same position in the cylinders at the same time. Likewise, No. 2 and No. 3 pistons are in the same position. If No. 1 piston is on the compression stroke, No. 4 must necessarily be on the exhaust stroke, and No. 2 and No. 3 on the suction and explosion strokes. On account of the arrangement of the cranks on the shaft, the order of firing in a four-cylinder engine must be 1, 3, 4, 2, or 1, 2, 4, 3. Either of these firing orders gives an even distribution of the power impulses. Ignition systems to be used on four-cylinder engines must have their timers, con-

tact makers, and distributors designed to deliver the spark to the cylinders of the engine in one of these firing orders. By a study of the timer in Fig. 83 and the distributor in Fig. 105, it can readily be understood how this is accomplished. These timers and distributors are driven at one-half crankshaft speed.

There are two ways in which cranks on a six-cylinder crankshaft are arranged. The sketches in Fig. 151 show this essential difference. Starting with crank 1 up, as shown, crank 2 may be either  $120^\circ$  to the right or left. Crank 3 is then  $120^\circ$  beyond crank 2. In either case, cranks 1 and 6, 2 and 5, 3 and 4 are in the same plane and in the same position. A crankshaft is either *right* or *left*, depending upon whether cranks 3 and 4

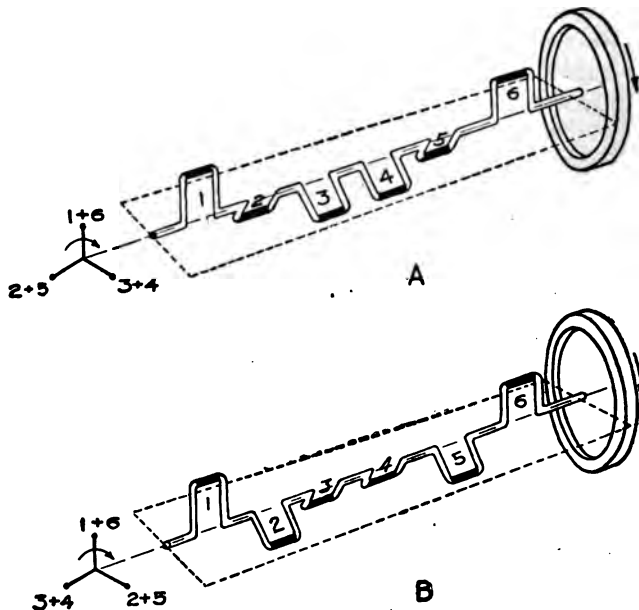

FIG. 151.—Methods of crank arrangement for six-cylinder engine.

are  $120^\circ$  to the *right* or *left* of cranks 1 and 6, when the latter are vertical. Figure 151A represents a *right* crank and Fig. 151B a *left* crank, the flywheel being at the far end of the shaft. As each cylinder fires once in two revolutions of the crankshaft, there are, consequently, three explosions per revolution, or one every one-third revolution of a six-cylinder crank.

The only essential difference between a *right* and a *left* crank is that in one case the flywheel is on one end of the crankshaft, while in the other it is placed on the opposite end. The crank arrangement determines the firing order, assuming that the direction of rotation is the same in each case. Referring to Fig. 151, obviously pistons 1 and 6, 2 and 5, and 3 and 4, will be in the same respective positions in their cylinders at the same time. If pistons 1, 2, or 3 are on the suction stroke, then pistons 6,

5, or 4 will be on the expansion stroke, If 1, 2, or 3 are on the compression stroke, then 6, 5, or 4 will be on the exhaust stroke. It is also evident that the cylinders can fire only in certain definite orders. For instance, the right crank in Fig. 151A might fire, 1, 5, 3, 6, 2, 4, or 1, 2, 3, 6, 5, 4, or 1, 5, 4, 6, 2, 3, or 1, 2, 4, 6, 5, 3. The first order given, 1, 5, 3, 6, 2, 4, is the best and most usual firing order because the power impulses are better distributed along the crankshaft. The left crank, Fig. 151B, might fire 1, 3, 5, 6, 4, 2, or 1, 4, 5, 6, 3, 2, or 1, 3, 2, 6, 4, 5, or 1, 4, 2, 6, 3, 5. The last order, 1, 4, 2, 6, 3, 5, is the best order for the reason given above.

**83. Firing Order of Eight-cylinder Engines.**—The eight-cylinder automobile engine has two rows or "blocks" of four cylinders each placed



FIG. 152.—Sectional view of Cadillac eight-cylinder engine.

at an angle of  $90^\circ$  with each other as shown in Fig. 152. The crankshaft is like the conventional four-cylinder crankshaft. The cylinders in the two blocks are opposite, and the connecting rods of opposite cylinders work on the same crank as shown in Fig. 153.

The cylinders of an eight-cylinder engine are generally numbered as shown in Fig. 154A, the right and left blocks being numbered from the radiator to the rear. The possible firing orders of each block are the same as in a four-cylinder engine. It will be noticed that on account of the cylinder blocks being placed at an angle of  $90^\circ$ , when the pistons of cylinders 1L and 4L are at the top of the stroke, pistons 2L and 3L are at the bottom of the stroke and all pistons of the right block are at the middle of the stroke, two of them moving towards the top and the other two towards the bottom. This means that the power impulses will be  $90^\circ$

apart, and that the firing will alternate from one side to the other. Although it is possible to have four firing orders for an eight-cylinder engine, two of these are practically never used. Both cylinder blocks usually fire in the 1, 3, 4, 2 order or the 1, 2, 4, 3 order. If in the 1, 3, 4, 2

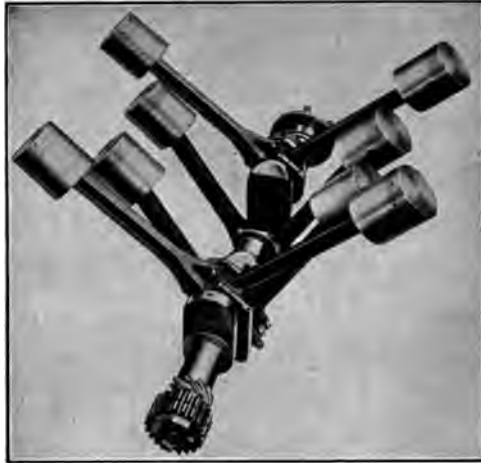

Fig. 153.—Cadillac crankshaft, piston, and connecting rod assembly.

order, the firing order for the engine is 1L, 2R, 3L, 1R, 4L, 3R, 2L, 4R as shown in Fig. 154A. If the 1, 2, 4, 3 order is used, the engine fires 1L, 3R, 2L, 1R, 4L, 2R, 3L, 4R as in Fig. 154A.

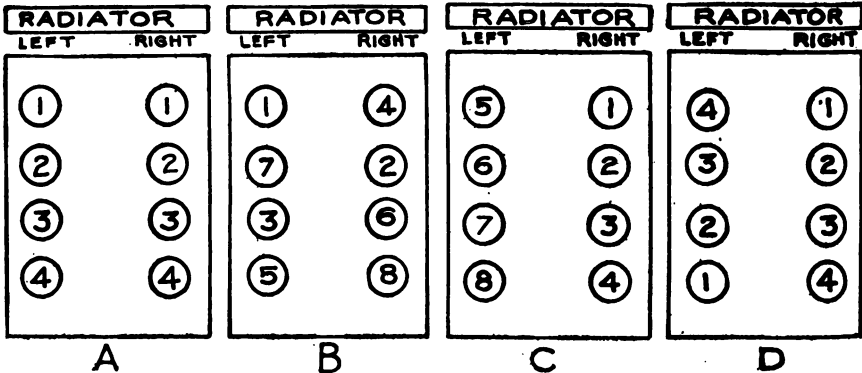

Fig. 154.—Methods of numbering the cylinders on an eight-cylinder engine.

The system of numbering the cylinders is not always as shown in Fig. 154A. The cylinders may be numbered in the order of firing as on the Cadillac, Fig. 154B, or as on the Cole car, Fig. 154C, where the cylinders are numbered 1, 2, 3, 4, on the right side, beginning at the radiator, and 5, 6, 7, 8 on the left side, also beginning at the radiator. The order of

firing on the Cadillac corresponds to the order previously given, 1L, 2R, 3L, 1R, 4L, 3R, 2L, 4R. The firing order on the Cole is 1, 8, 3, 6, 4, 5, 2, 7, as in Fig. 154C, which is the same order as on the Cadillac. The numbering and order of firing on the Oldsmobile and King Eight are the same as on the Cole car, Fig. 154C.

**84. Determining the Firing Order of an Eight-cylinder Engine.**—If it becomes necessary to determine the firing order of an eight-cylinder engine it can be easily done by assuming that the cylinders are numbered as indicated in Fig. 154D. The firing order for the right block is determined by cranking the engine so that cylinder No. 1 is on compression. By further cranking, it can be determined whether cylinder No. 2 or cylinder No. 3 is next on compression. If No. 1 is followed by No. 2, the firing order for the block will be 1, 2, 4, 3; if No. 1 is followed by No. 3, the order will be 1, 3, 4, 2. The firing order for the engine can then be determined by starting with right cylinder No. 1, following this with left cylinder No. 1, and then by R2, L2, R4, L4, R3, L3 if the firing order of the block is 1, 2, 4, 3. If the firing order of the block is 1, 3, 4, 2, then the order for the engine will be R1, L1, R3, L3, R4, L4, R2, L2.

If the distributor and the ignition system have been installed, the easiest way to determine the firing order of any engine is to note the direction of rotation of the distributor arm. The cable from the spark plug in cylinder No. 1 on the right block, or the front cylinder if the engine has but one block, is followed to the distributor and the distributor terminal to which it is attached noted. By noting to which cylinders the successive cables lead, when going around the distributor in the direction of rotation of the distributor arm, the firing order can readily be determined. This method is the better when the ignition system is already installed; if this is not the case, the first method must be used.

**85. The Delco Ignition System for the Oldsmobile Eight.**—A typical eight-cylinder ignition system is the Delco ignition equipment as installed on the Model 45A Oldsmobile Eight. The ignition unit, consisting of the interrupter and an eight-point distributor, is mounted vertically on the commutator end of the electrical generator, Fig. 155. The generator in turn is mounted between the cylinder blocks at the front end of the engine as shown in Fig. 156. The ignition unit, although mounted on the generator which is driven by the fan belt, is not driven from the generator shaft but has an independent drive consisting of a vertical shaft with a spiral gear which meshes with a gear on the camshaft.

In the lower part of the ignition unit case is located the automatic spark advance mechanism of the conventional centrifugal weight governor type. Immediately above is the breaker and at the top the distributor covered by its hard rubber cap. The condenser is located within the breaker housing in close association with the breaker points. The cam operating the breaker has eight lobes so as to give eight sparks per revolu-



tion of the cam, the ignition unit being driven at one-half crankshaft speed.

The coil used is of the regular Delco tubular three-terminal form with the resistance unit carried at one of the primary terminals. The coil is mounted on a bracket secured to the engine side of the dash. The wiring

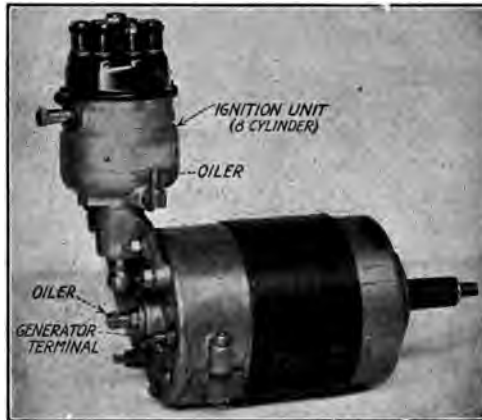

FIG. 155.—Delco generator and ignition unit for Oldsmobile Eight.

diagram of the electrical equipment on the Oldsmobile Model 45A is shown in Fig. 157. The different parts of the electrical equipment are shown here in their relative positions, and, consequently, the parts described can be readily located.

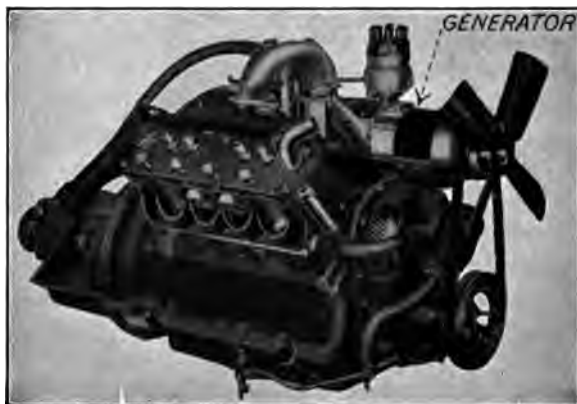

FIG. 156.—Delco ignition installation on Oldsmobile eight-cylinder engine, model 45A.

**86. The Delco Ignition System for the Cadillac Eight.**—This ignition system embodies the following elements: A *source of current*, the generator, or at low engine speeds, the storage battery; an *ignition timer or interrupter*, which interrupts the low-tension current at the proper instant

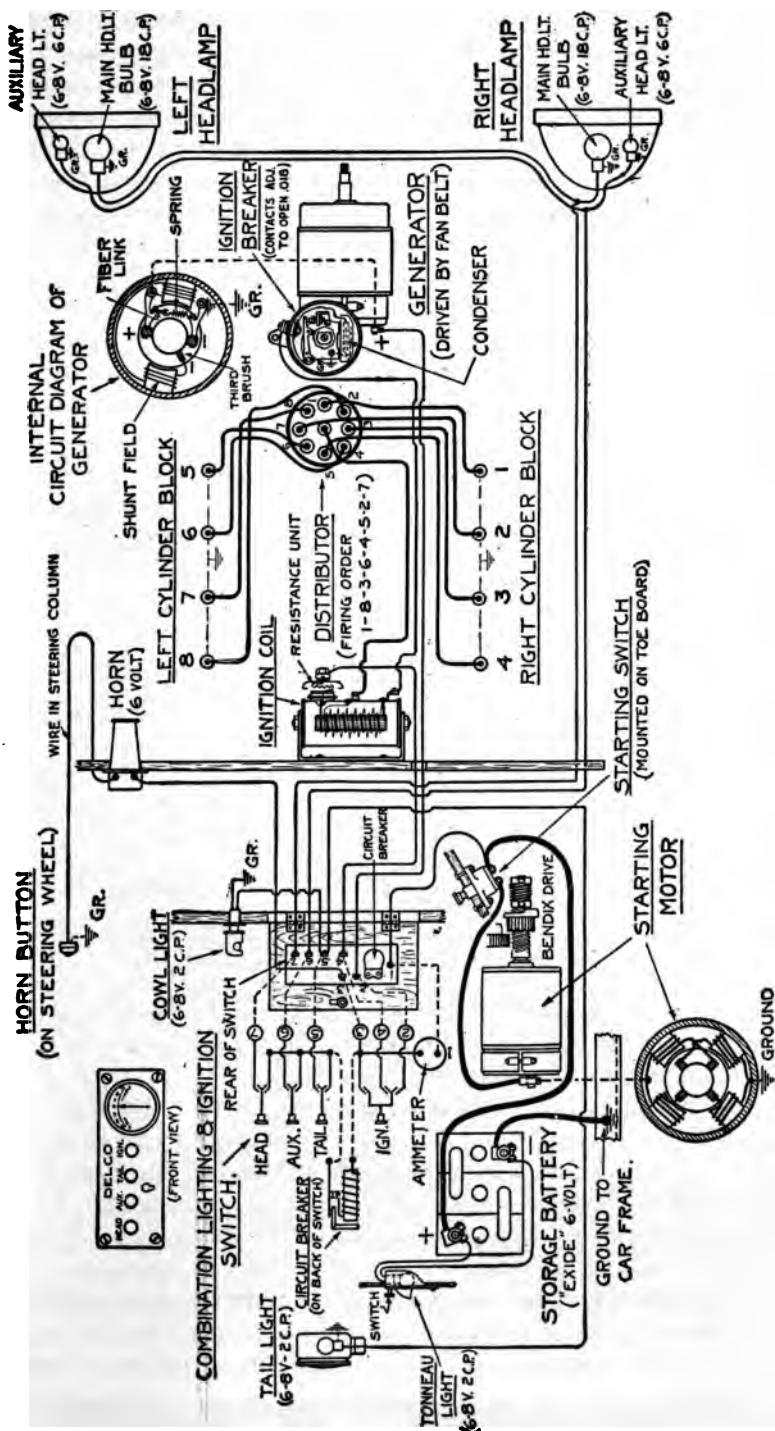

Fig. 157.—Circuit diagram of Delco starting, lighting, and ignition system on Oldsmobile Eight, model 45A.

to produce a spark in the high-tension circuit; an *induction coil*, transforming the primary current of six volts into one of sufficient voltage to jump the gaps in the spark plugs; a *condenser*, which assists the inductance coil to raise the voltage, and which protects the contact points of the breaker from burning; and a *high-tension distributor*, which directs the distribution of the high-tension current to the spark plugs in the respective cylinders. These various parts are shown in Fig. 158. The combination switch, which controls the lighting as well as the ignition circuit, is shown in the upper left-hand portion of the figure. The ignition circuit is controlled by means of the right-hand lever on this switch. The switch is mounted on the instrument board. The coil is shown in the upper right-hand corner and below it is the resistance unit followed by the interrupter and condenser connected in parallel between the resist-

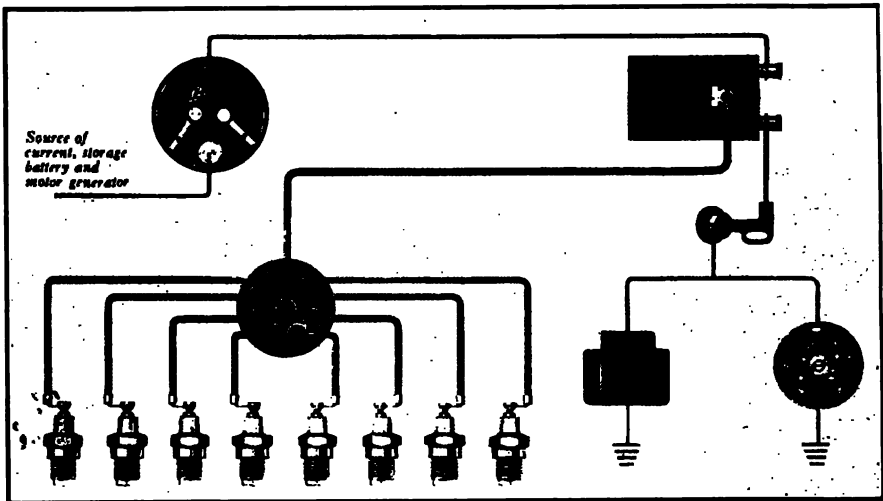

FIG. 158.—Elements of Cadillac Eight ignition system.

ance unit and the ground. The distributor, with its leads to the eight spark plugs, is shown to the left of the condenser. The wiring diagram of the system is shown in Fig. 159.

The interrupter, the distributor, the condenser, and the automatic spark advance mechanism are all located in a compact unit mounted on the fanshaft housing and are driven by the fanshaft through spiral gears. Figure 160 is a view of the Cadillac engine and shows the ignition unit mounted between the blocks on the fanshaft housing. One feature of this installation is the fact that the ignition unit is completely enclosed by a metal container, and has metal conduits leading from the unit to each cylinder block to carry the high-tension spark plug wires. The cover protects the unit from dust, and the conduits protect the wires from accidental injury.

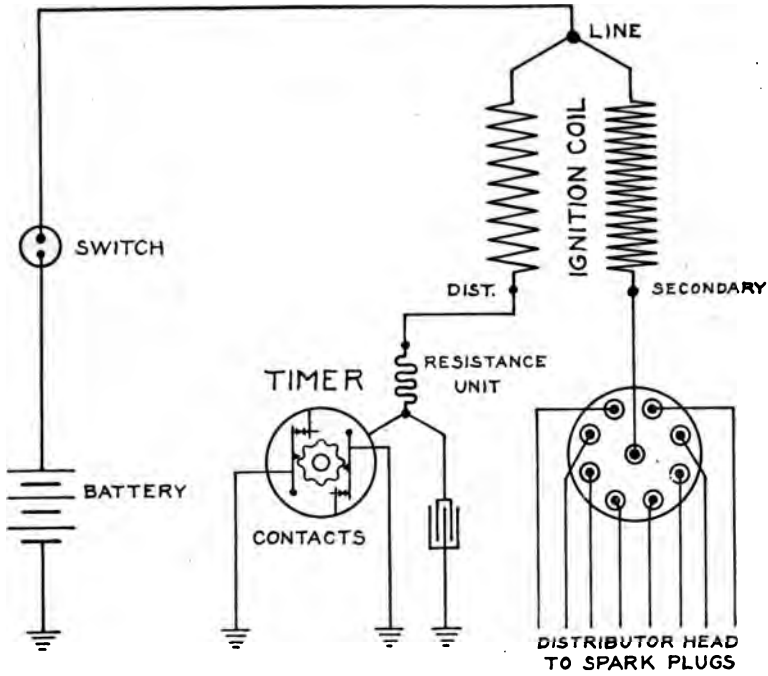

FIG. 159.—Wiring diagram, Cadillac Eight ignition system.

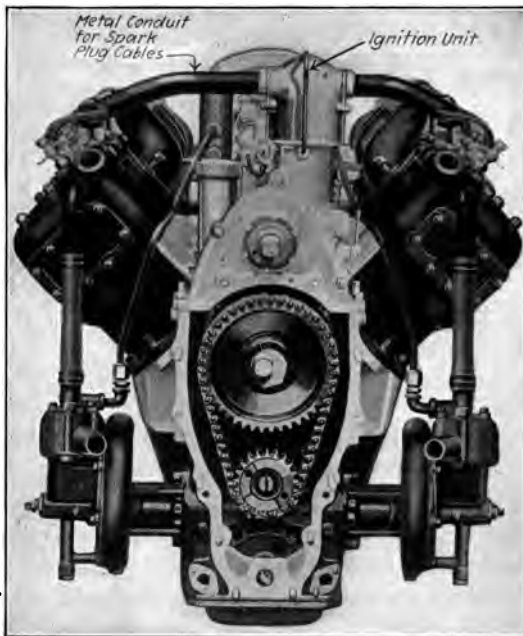

FIG. 160.—Cadillac eight-cylinder engine showing ignition system.

Figure 161 is a sectional view of the ignition unit showing the distributor at the top, the timer or interrupter below, and the automatic spark advance mechanism in the bottom. The condenser is mounted on the right-hand side of the unit in a waterproof casing. The spark timing is controlled automatically by the automatic spark advance mechanism which advances or retards the position of the timer cam relative to the driving shaft, as the engine speed increases or decreases. A spark lever at the steering wheel is provided, however, by which the timing may be

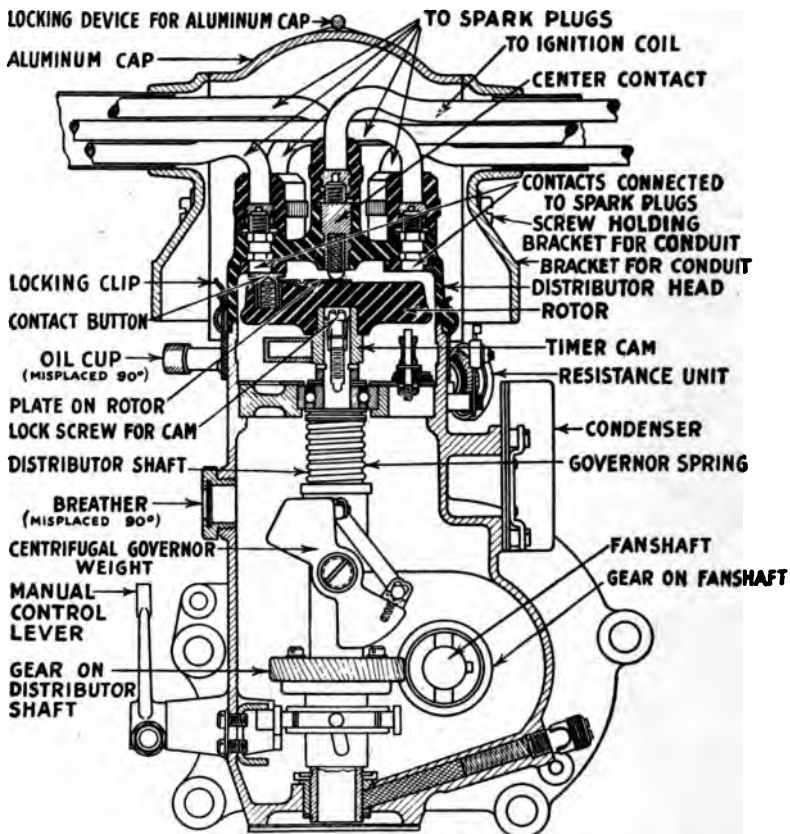

FIG. 161.—Sectional view of Cadillac Eight ignition unit.

further advanced or retarded. This spark lever is connected to the manual control lever at the left of the distributor housing.

The timer or interrupter used on this system is shown in Fig. 162. The striking feature of this timer is that it employs two sets of contact points. The eight-lobed cam on the timer shaft operates two contact arms. These contact arms and the contact points are connected into the circuit in parallel, as shown in the wiring diagram Fig. 159, and each set of contact points handles but one-half of the primary current, thus reduc-

the wear and also the pitting and burning of the points. To accomplish this, however, it is absolutely necessary that both sets of contact points be adjusted to open at exactly the same instant and exactly the same amount. The proper distance between points, when opened, is .020 in. This adjustment should be watched carefully and kept correct because if one set of contact points wears slightly more than the other set, the one set will open first, leaving the second set still closed. The primary current will then be flowing through the second set. When the second contacts open, the arcing and pitting will be as bad as if the first set of contact points were not present. This latter condition would, of course, defeat the object of installing the two sets of breaker points.

**87. Firing Order of Twelve-cylinder Engines.**—The twelve-cylinder engine has two blocks of six cylinders each. The blocks are arranged in a V with an included angle of 60° as shown in Fig. 163. One block of

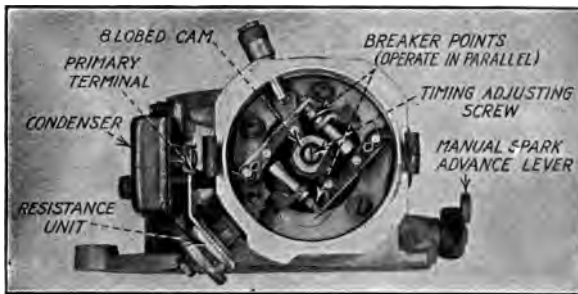

FIG. 162.—Delco breaker mechanism used on Cadillac Eight, model 57.

indicators is usually set ahead of the other by about  $1\frac{1}{4}$  in. to permit the other end of the connecting rods of opposing cylinders to be placed side by side on the same crank pin. The crankshaft is of the conventional cylinder type, with three main bearings, similar to one or the other of the forms shown in Fig. 151.

The several methods of numbering the cylinders on a twelve-cylinder engine are shown in Fig. 164. The firing order in each block is similar to that in a six-cylinder engine and is usually 1, 5, 3, 6, 2, 4, or 1, 4, 2, 6, 5, with the cylinders numbered as in Fig. 164A, the impulses alternating from one side to the other.

On the Packard engine, numbered as in Fig. 164A, the firing order is 6L, 4R, 3L, 2R, 5L, 6R, 1L, 3R, 4L, 5R, 2L, corresponding to a firing order for each block of 1, 4, 2, 6, 3, 5. On the Pathfinder, numbered as in Fig. 164C, the firing order is 1R, 1L, 4R, 4L, 2R, 2L, 6R, 6L, 3R, 3L, 5R,

This order is the same as used on the Packard, and can be determined by a careful study of the firing orders given above and the methods of numbering the cylinders. The order of firing for the National twelve,

with the cylinders numbered as in Fig. 164*B*, is 1, 12, 9, 4, 5, 8, 11, 2, 10, 7, 6. This corresponds to an order of 1, 5, 3, 6, 2, 4 for each block numbered as in Fig. 164*A*.

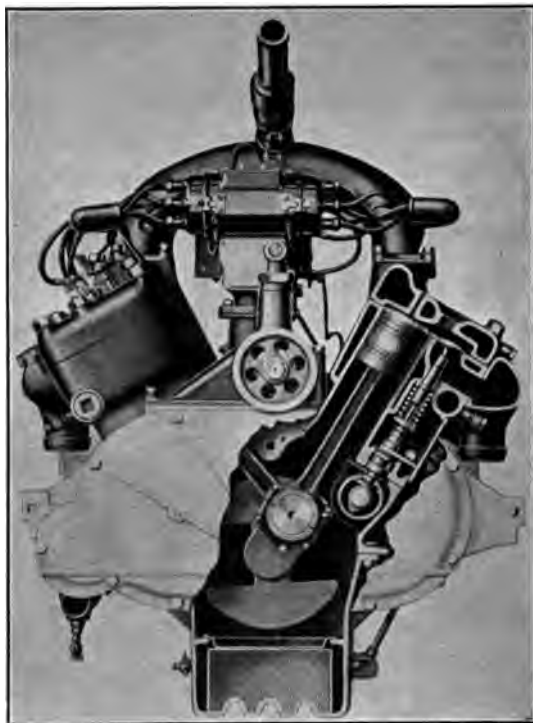

FIG. 163.—National twelve-cylinder engine.

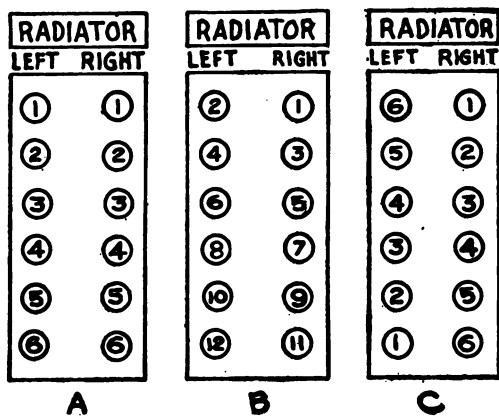

FIG. 164.—Numbering of cylinders on twelve-cylinder engines.

Perhaps the best way to determine the firing order of any twelve-cylinder engine is to number the cylinders of the right block starting :

the radiator end and the cylinders of the left block starting at the other end of the engine as shown in Fig. 164C. Considering only the right block, the engine should be cranked by hand with the priming cocks open or the spark plugs removed until cylinder No. 1 on the right block is on compression. By further cranking, it can be determined whether cylinder No. 5 or cylinder No. 4 of the right block is next on compression. If No. 5 is next, the firing order for the right block is 1, 5, 3, 6, 2, 4. If No. 4 is next, the firing order for the right block is 1, 4, 2, 6, 3, 5 as explained in Section 82 of this chapter. Knowing the firing order of the right block, the firing order of the engine is found by following each cylinder on the right block by the cylinder of the same number on the left block. For instance, if the firing order of the right block is 1, 5,

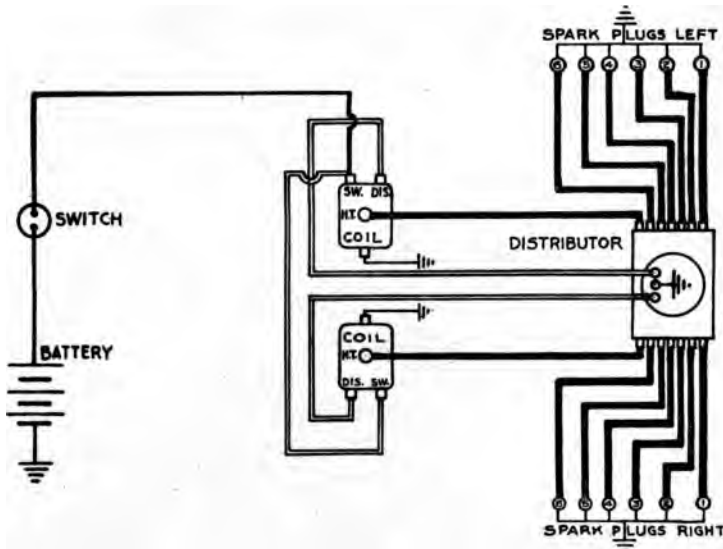

FIG. 165.—Wiring diagram, Packard Twin Six ignition system.

3, 6, 2, 4, the firing order of the engine is 1R, 1L, 5R, 5L, 3R, 3L, 6R, 6L, 2R, 2L, 4R, 4L, with the cylinders numbered as in Fig. 164C. Knowing the firing order with the cylinders numbered as in Fig. 164C, the firing order with the cylinders numbered as in Fig. 164A or in Fig. 164B is easily found.

**88. The Delco Ignition System for the Packard Twin Six.**—As the number of cylinders is increased on an engine, the load or duty imposed on the ignition system becomes proportionately greater. The ignition systems for the four- and six-cylinder engines are relatively simple, but the eight- and twelve-cylinder engines require special means for producing the large number of sparks required, and at the same time keep the wear on contact points and other parts down to a reasonable limit. This was



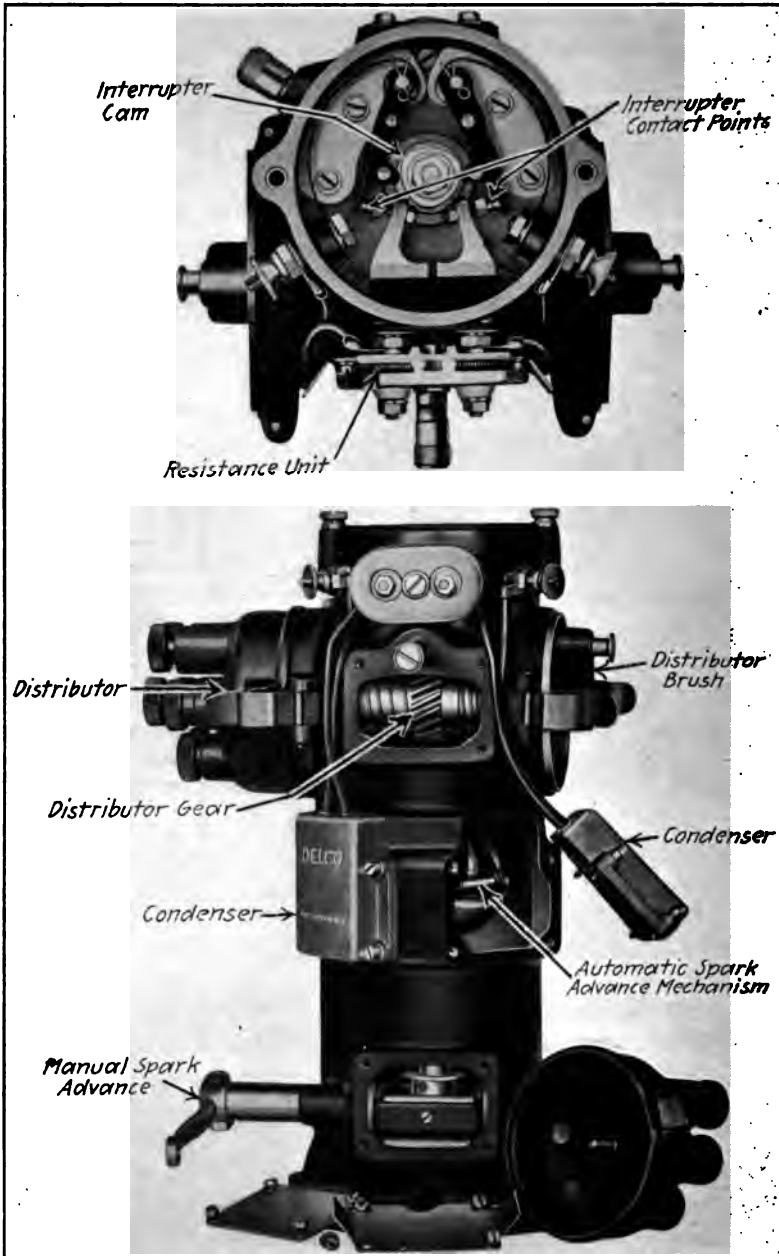

FIG. 166.—Ignition unit, Packard Twin Six.

accomplished on the Cadillac Eight by providing two sets of breaker points that operate in parallel. On the Packard "Twin Six," with its high speed twelve-cylinder engine, the same result is accomplished by using a coil, an interrupter, and a distributor for each block of six cylinders. This gives practically a separate ignition system for each block.

The primary current from the battery divides into two parallel paths through the ignition switch, giving each block an individual primary circuit incorporating a coil, a breaker, and a condenser. This arrangement

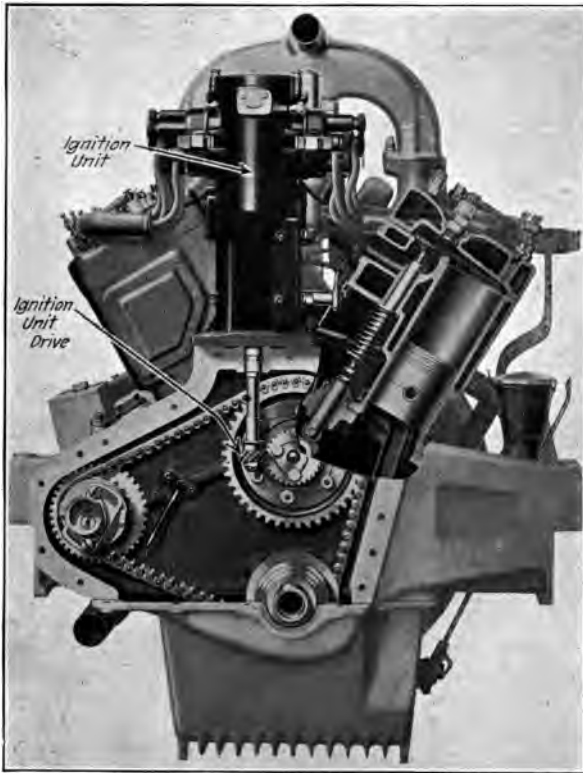

FIG. 167.—Front view of Packard Twin Six engine showing ignition unit drive.

requires two distributors, each controlling the distribution of the high-voltage secondary current to the six cylinders in its respective block. The wiring diagram is shown in Fig. 165.

The distributors, the breakers, and the condensers are all mounted on the vertical ignition unit shown in Fig. 166. The upper view is the breaker box containing its two contact arms, one for each primary circuit. These arms are operated by a three-lobed cam that revolves at crankshaft speed thus giving three sparks in each block per revolution of the crankshaft, or six sparks and six explosions per revolution of the crankshaft for

the entire engine. The two breaker arms are so placed that the points in the two primary circuits open in the proper sequence to give the correct firing order.

Below the breaker box are the two distributors, one on either side, driven by spiral gears from and at one-half the speed of the vertical shaft which carries the breaker cam.

Two condensers, one for each pair of primary contact points, are mounted on the ignition unit housing. These condensers serve as cover plates for openings in the housing through which the automatic spark advance mechanism in the lower part of the case may be examined. The ignition unit is mounted between the blocks at the front of the engine and is driven by spiral gears from the camshaft as shown in Fig. 167.

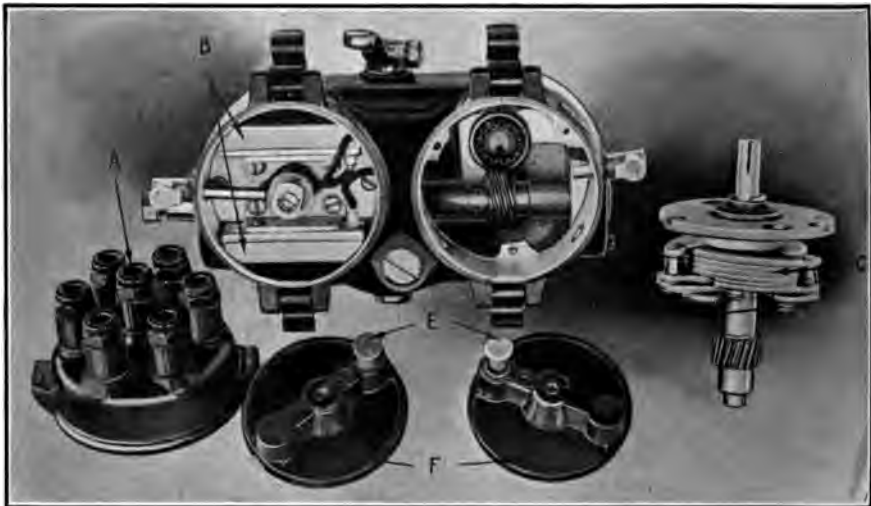

FIG. 168.—Pierce-Arrow ignition unit showing condenser mounting and driving mechanism.

**89. Delco Ignition for Pierce-Arrow Dual Valve Six.**—The Pierce-Arrow Dual Valve Six engine is distinctive in that it has two inlet and two exhaust valves and two spark plugs for each cylinder. The engine is provided with a dual battery ignition system. This means that the ignition system is equipped with two independent sets of spark plugs, condensers, breaker points, transforming coils, etc. The ignition switch is so constructed that either or both sets of ignition may be operated at will. The double system is recommended because under such conditions two spark plugs are being fired synchronously in each cylinder. This means a considerable increase in power and more miles per gallon of fuel because of the better combustion when the charge of gas is ignited from two points. The single system can be used when it is desired to test out the ignition system, or under special conditions where the storage battery might be badly discharged.

The double distributor, Fig. 168, is equipped with an automatic spark advance which is located on the lower part of the vertical shaft which carries the interrupter cam *H*, Fig. 169. To this shaft is attached a centrifugal type of governor, which is so designed that as the engine speed increases, the governor weights are thrown outward by centrifugal force. The movement of the governor weights revolves the top of the interrupter shaft through a slight angle in the proper direction to advance the spark.

The battery breaker points *KL* and *EP*, Fig. 169, should be set to open approximately .015 in. A special wrench is furnished by the makers

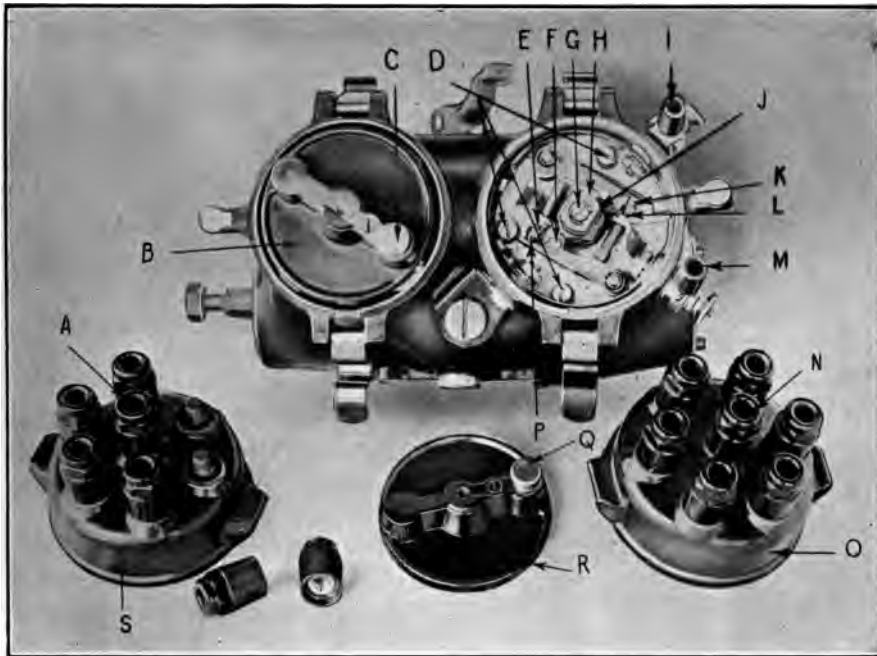

FIG. 169.—Pierce-Arrow ignition unit showing distributor and interrupter mechanism.

for this purpose and is equipped with two gages, one for the approximate setting of the spark plug gaps and the other for the approximate opening of the breaker points. These breaker points are of tungsten and normally need but little attention; in instances where it is necessary to adjust the points, as wearing takes place, it is not necessary to take special pains to true the points up so that they will make contact over their entire surfaces, as they have a tendency to true themselves up in service.

Before putting a car into service it is advisable to put a little vaseline around the track in the distributor heads *S* and *O*, Fig. 169, on which the contact button *Q* travels. After this is done, any excess

vaseline should be wiped from the track with a dry cloth. In other words, it is not desirable to permit this lubricant to remain in quantities upon the surface of the insulator.

The fiber cams *F* and *J*, Fig. 169, on the breaker arms will wear slightly in the first few hundred miles of use. After the car has been run about one thousand miles, the setting of the breaker points should be checked. The breaker points should operate in exact synchronism;

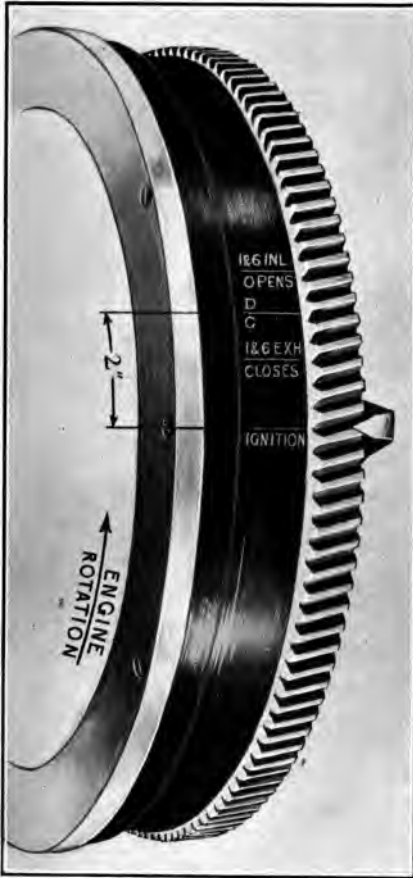

FIG. 170.—Position of flywheel for ignition timing on Pierce-Arrow Dual Valve Six.

that is, they should open at the same instant, or the advantage of having two sets of spark plugs in each cylinder will be lost. If it is desired to make them open at a point more closely approaching exact synchronism, it can be done by loosening the three screws *D*, Fig. 169, on the sub-base to which these breaker mechanisms are attached. After the screws are loosened, the sub-base may be moved about within limits until the desired equalization is obtained. The screws should then be tightened. The firing order of the engine, 1, 5, 3, 6, 2, 4, is imprinted on the Bakelite distributor heads *S* and *O*, Fig. 169, with the proper cylinder number opposite each terminal.

For timing this double ignition system with the engine, the flywheel should first be placed so that the indicator is over the "ignition" mark on the flywheel as shown in Fig. 170. Care should be taken to see that the engine is on the compression stroke of No. 1 cylinder when this is done. The distributing arms in the Delco unit, Fig. 168, should then be set in a position

to be firing No. 1 cylinder as marked on the head of the distributors. Both sets of breaker points should just be beginning to open with the spark lever fully retarded. In this position, the distributor unit should be coupled to the driving flange.

The two coils used with this double system are mounted on the engine side of the dash as shown in Fig. 171. Each coil carries a re-

sistance unit to protect the coils, should the ignition switch be accidentally left "ON" with the engine not running. The wiring diagram

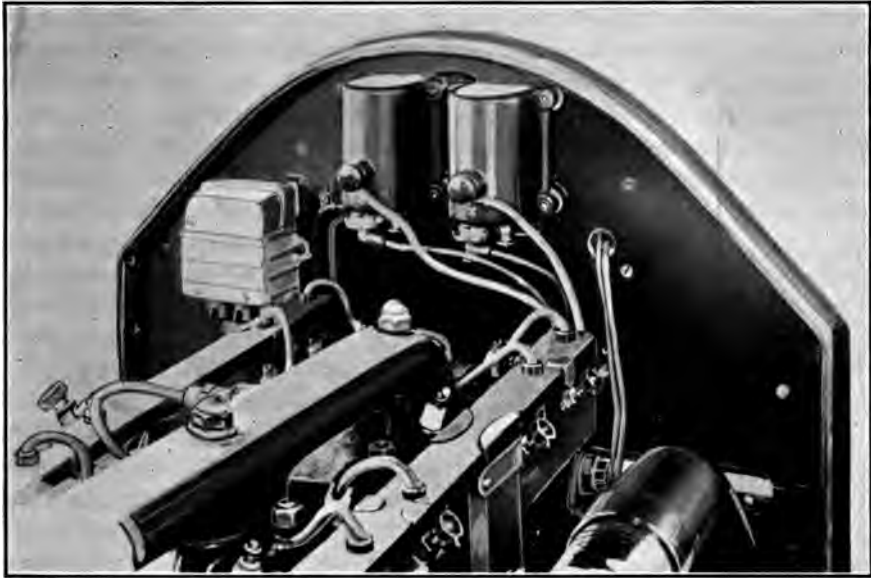

FIG. 171.—Dash of Pierce-Arrow showing location of ignition coils.

for the double ignition system of the Pierce-Arrow Dual Valve Six is shown in Fig. 172.

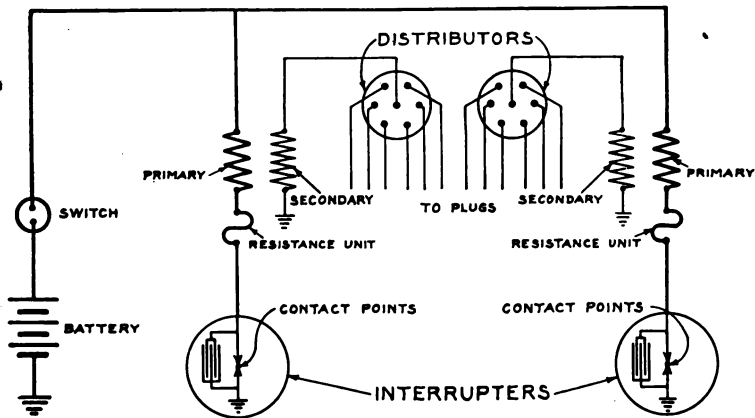

FIG. 172.—Wiring diagram, Pierce-Arrow Dual Valve Six ignition system.

**90. Ignition Requirements of Liberty Twelve Aircraft Engines.—**The service expected of aircraft engines is so severe and exact that nothing is overlooked that will better the performance of these engines.

The life of the aviator and the success of his flying depend on the consistent performance of all parts entering into the construction of the power plant. The ignition systems used on airplane engines have been developed to keep pace with the improvements made in other parts. The result of these improvements is an ignition system that can be depended upon to deliver a spark to the cylinder under practically any condition met in the most strenuous military service. Two complete and independent ignition systems are provided, either of which will fire all twelve of the engine cylinders. This duplication of ignition system precludes the possibility of the engine becoming stalled, due to the failure of the ignition system. The two systems may be used at the same time giving two sparks in each cylinder, an advantage in high speed flying.



FIG. 173.—Special storage battery for airplane service.

The engine is cranked or started by pulling over on compression by means of the propeller. The compression is tested by rocking the engine back and forth several times by the propeller. It is very necessary that the engine should not kick back at these times or severe injury to the mechanics may result. The interrupter used on the aircraft engines was developed with this in mind making a back kick impossible. The method of accomplishing these results, as explained by the Equipment Division of the U. S. A. Signal Corps, is given in the following paragraphs.

#### 91. The Delco Ignition System for Liberty Twelve Aircraft Engines.

The ignition system used on the "Liberty Twelve" aero engines is known as the generator-battery type. This system comprises two independent breaker and distributor mechanisms or heads, identical in every respect and each firing all twelve cylinders. These distributors are supplied with electrical energy from two sources. For starting and for idling speeds up to 650 r.p.m. current is drawn from a specially constructed four-cell storage battery. This battery, Fig. 173, is very light and carries very little liquid or electrolyte (barely enough to fill a hydrometer syringe, besides what is absorbed by the plates and separators). Nevertheless, it has sufficient capacity to ignite the engine at full speed for three hours. It is so constructed that, even though it be turned upside down, it will still continue to function properly.

*Generator.*—In addition to the battery, a positively driven generator is provided, so geared that it runs at one and one-half times crankshaft speed. As stated above, electrical energy for starting and idling speeds is supplied by the battery. As the engine speed is increased, the generator “builds up” and its output grows greater until, at about 650 r.p.m., the generator voltage equals that of the battery. The maximum generator output exceeds the requirements for ignition so that, at a speed above 650 r.p.m., the direction of flow of current is reversed and the excess output of the generator goes to recharge the battery. The rate at which the battery will be recharged will depend upon the condition of the battery. With an almost discharged battery, the rate will be about 10 amperes, but will diminish as the battery voltage rises until the battery is completely charged, when the charging rate will be just sufficient to maintain the battery in a properly charged condition.

*Regulation.*—The generator is controlled by a voltage regulator which prevents the output exceeding a predetermined figure. In view of this fact, the generator will supply current for ignition indefinitely, without the battery, as long as the engine speed is not allowed to drop below 500 r.p.m. It is not possible to crank the engine fast enough to start it on the generator, however.

*Switch.*—A duplex ignition switch is provided which will permit either one or both distributors to be turned “ON.” This switch is so constructed that either ignition set can be used alone without connecting in the generator. In starting, only one side should be used since with both switches “ON” the generator is connected to the battery. Under this condition, the discharge from the battery through the generator before the engine is started would be an excessive drain on the battery. It is essential, however, that both switches be “ON” at all flying speeds. The ignition switch has an ammeter incorporated in it, and this ammeter indicates the amount of current flowing to or from the storage battery. If the ammeter shows a discharge at any speed above 650 or 700 r.p.m., with both switches “ON,” it is an indication that something is wrong with the generator circuit and that all electrical energy is being supplied from the battery. If the ammeter stands at zero, under the same conditions, it indicates that the storage battery is not receiving a charge, but that the ignition is being carried by the generator.

*Distributors.*—The interrupter, the condenser, the distributor, and the coil are all contained in one compact unit. Two of these units are provided, one being mounted near the top of each row of cylinders as is shown in Fig. 174. These units are driven direct from the camshafts, which are mounted above the two rows of cylinders. The interior construction of the interrupter is shown in Fig. 175. The circuit breaker mechanism for each of the distributor heads is identical with



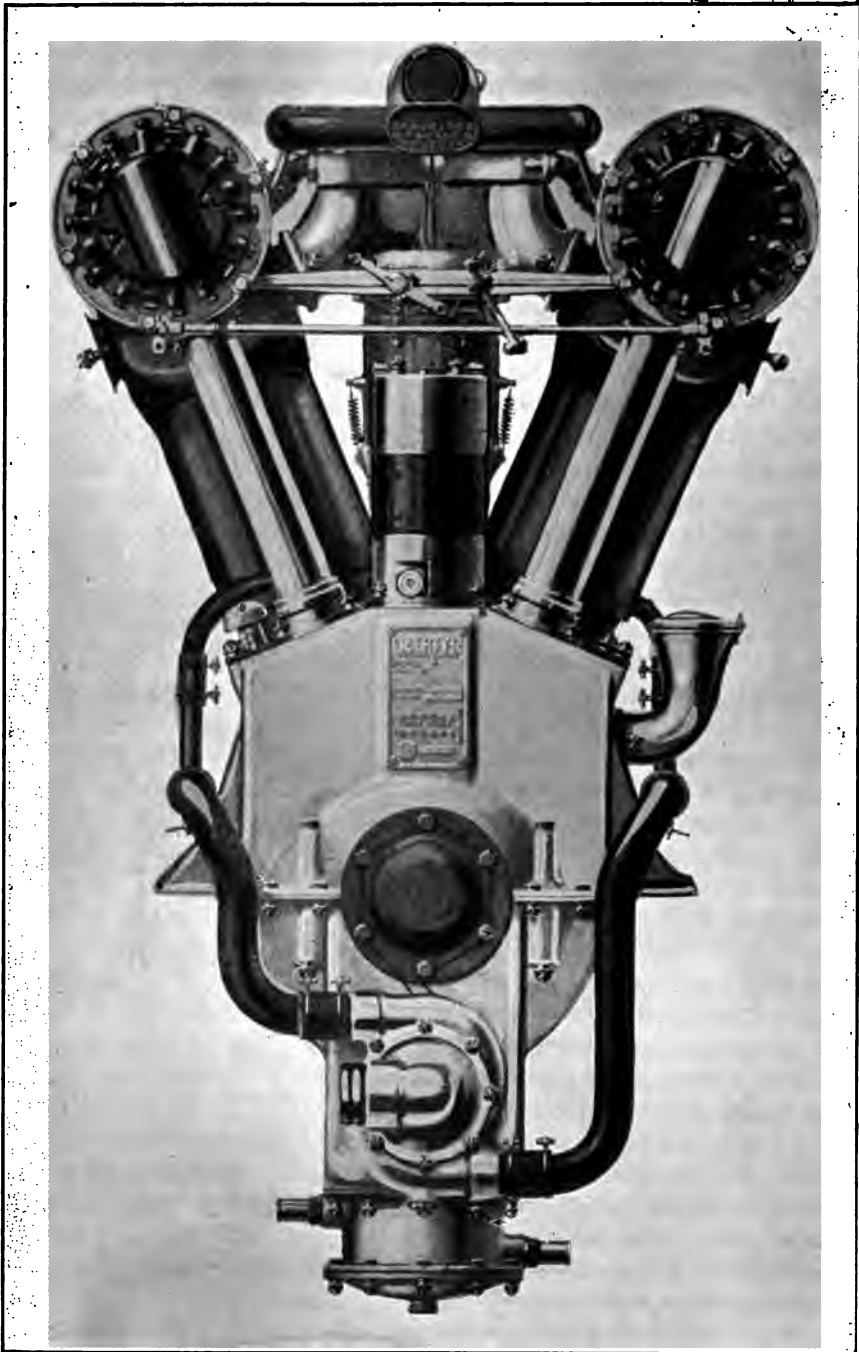

FIG. 174.—Liberty Twelve aircraft engine showing location of ignition units.

that used in high-grade magneto or battery ignition systems, with two exceptions, as follows: Two main circuit breakers, connected in parallel, are provided instead of one. The two breakers are timed to operate simultaneously and are provided in duplicate as a precautionary measure. An auxiliary circuit breaker, the function of which is to prevent the production of a spark when the engine is turned backward or "rocked," is also provided. This auxiliary breaker is connected in parallel with the other two through a resistance unit which reduces the amount of current flowing through it. The breaker is so timed that it opens slightly *before*

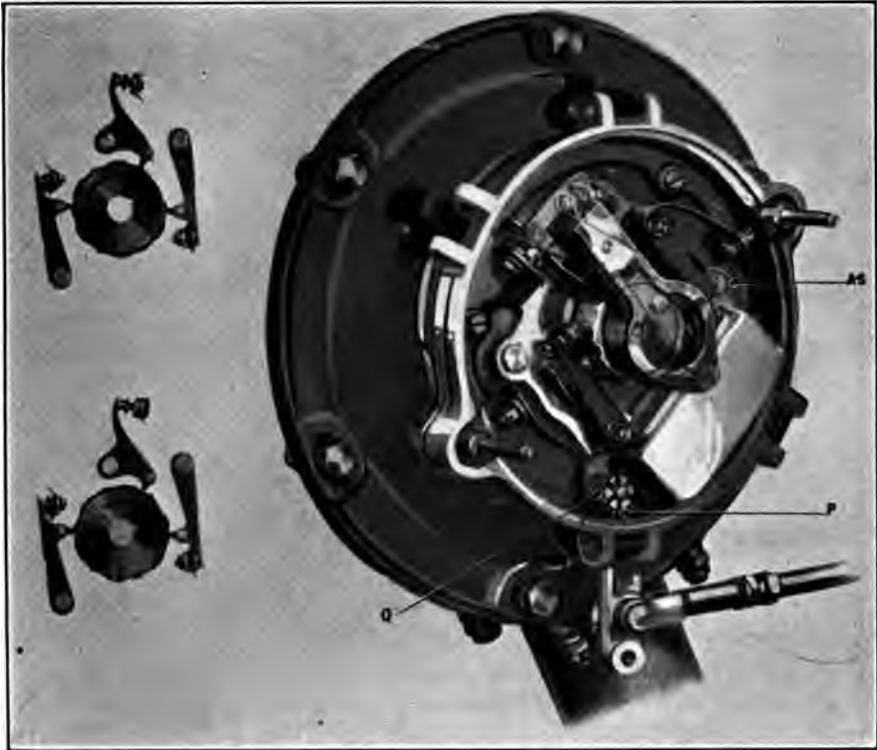

FIG. 175.—Interrupters, Liberty Twelve aircraft engine ignition system.

the other two when the engine is turned in a forward direction. The opening of the main breakers then results in the production of a spark. When the engine is turned in a *backward* direction, the two main breakers open first and no spark is produced, due to the fact that the current continues to flow through the coil through the auxiliary breaker, but in diminished quantity, due to the resistance unit. By the time the circuit is opened, at the auxiliary breaker, the intensity of the magnetic field of the coil has weakened to such an extent that no spark is produced. This action prevents an explosion in the cylinder, when the engine is being

cranked backwards, or when it rocks back after being pulled over on compression. An unexpected explosion in the engine might result in severe injury to the men handling the propeller when starting the engine.

The advantages this system presents over the magneto system are:

1. Easy starting—a spark of greater intensity is produced at cranking speed than at flying speed.

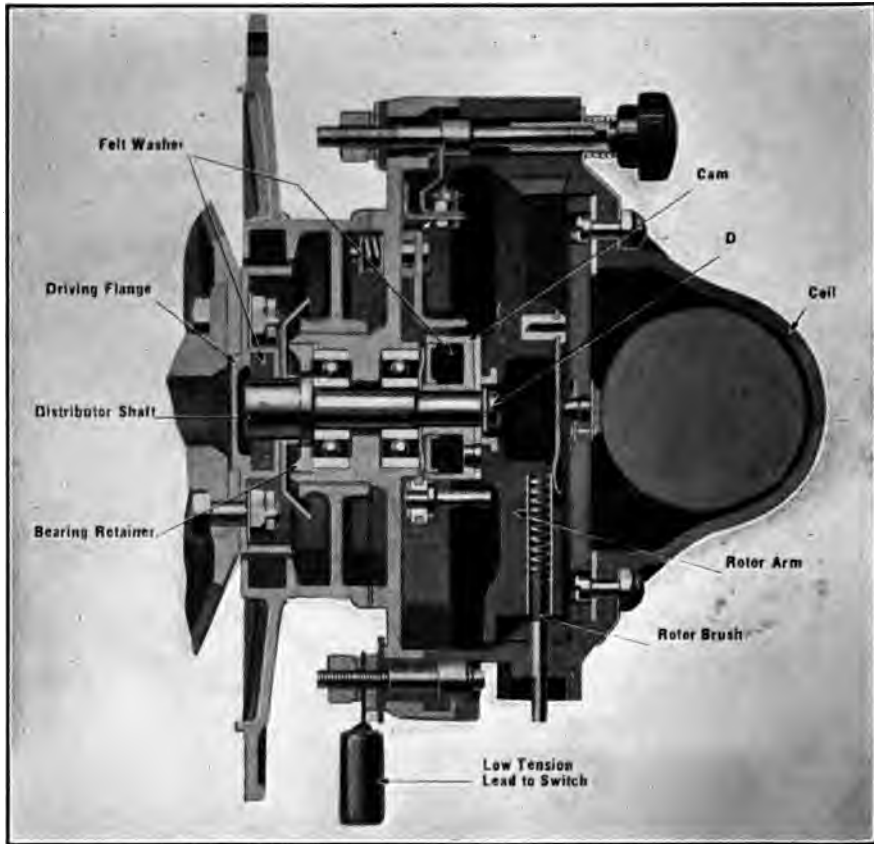

FIG. 176.—Cross section of Liberty Twelve aircraft engine distributor, showing location of coil.

2. Reliability—two distinct distributor mechanisms, each igniting all twelve cylinders through separate spark plugs, each distributor head being fitted with two sets of breaker arms and contact points. Two distinct sources of electrical energy—the battery and the generator.

3. Safety—the auxiliary breakers prevent the possibility of a back kick.

The transformer or induction coil is incorporated in the Bakelite insulation cover of each distributor head as shown in Fig. 176. This

location of the coil is ideal as it is completely covered and protected from damage and is also close to the distributor and interrupter so that very little wiring is needed to connect the coil into the circuits. The wiring incorporated in and is well protected by the hard insulation. The wiring diagram of the complete electrical equipment is shown in Fig. 177. No automatic spark advance mechanism is used, the time of the spark being controlled by the aviator by means of a small hand lever conveniently located on the control. A second lever controls the throttle. It has been found that the automatic spark advance is not adaptable to aircraft engines, the highly trained aviator being able to carry the spark at the proper point for best engine performance at all speeds. The lack of an automatic spark advance mechanism eliminates many of the complicated parts of the automobile ignition system and tends to promote reliability and to better the performance of the craft upon which this system is used.

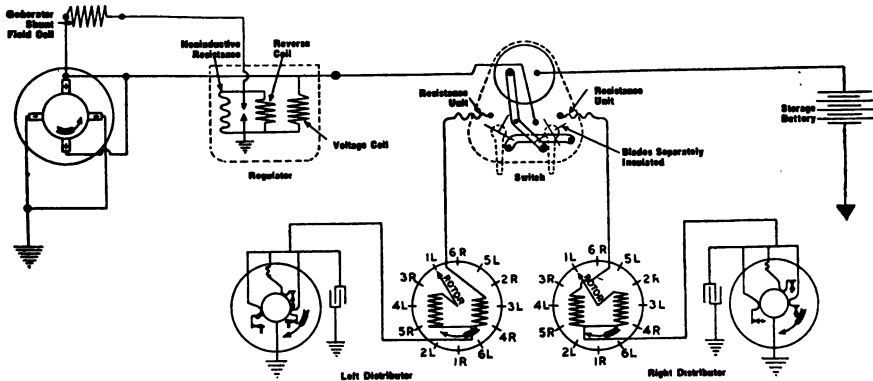

FIG. 177.—Circuit diagram of Liberty Twelve aircraft engine ignition system.

**92. Ignition Timing on Eight- or Twelve-cylinder Engines.**—The timing of the ignition system on an eight- or twelve-cylinder engine is very little different from the timing of a four- or six-cylinder ignition system. The same method is employed in each case. The firing order of the engine should be determined by the method described in this chapter. The next step is to set cylinder No. 1 on the firing position, which is generally 5° (on the flywheel) past upper dead center on the working or expansion stroke. Then with the spark level fully retarded, the screw holding the breaker cam should be loosened and the breaker cam turned until the breaker points are just opening and the distributor arm is on the distributor segment having the high-tension cable leading to the spark plug in cylinder No. 1. The breaker cam should be tightened in this position, and the remaining high-tension cables connected to the plugs in the cylinders according to the firing order previously determined, going around the distributor in the direction of rotation of the distributor arm.



## CHAPTER VI

### THE LOW-TENSION MAGNETO

**93. Magneto Classification.**—The magneto, which is used very extensively for ignition purposes on automobiles, trucks, and tractors, consists essentially of two parts, the *magnets* which supply the magnetic field, and the *armature* which carries the winding and which usually must revolve in this magnetic field in order to generate a current. The magneto is built in two general types according to the methods employed for generating the current, namely, the *armature wound* or H type and the *inductor* type. In the armature wound type, the current is generated

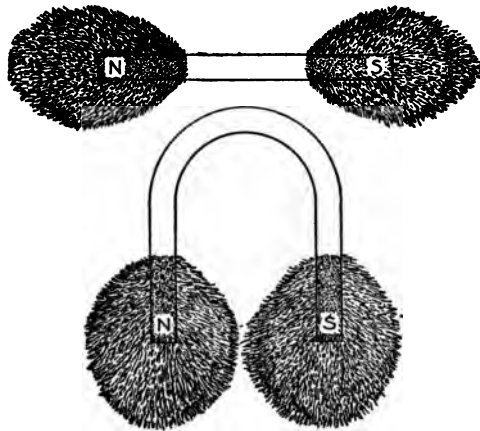

FIG. 178.—Bar and horseshoe magnets.

in a winding revolving in and cutting the magnetic field. In the inductor type, the winding in which the current is generated is stationary. The current is generated by the reversal of the magnetism through the coil and the cutting of the winding by lines of force. The magneto may also be classified either as *high-* or *low-tension*, according to the voltage of the current which it generates. Both the high- and low-tension magnetos may be constructed on either the armature wound or the inductor principle.

**94. Magneto Magnets.**—It is a well-known fact that either in a bar magneto or in a magnet bent in the shape of a horseshoe, as in Fig. 178, the magnetic strength is concentrated near the ends, as indicated by the bunches of iron filings at the ends of these magnets. One end of the mag-

net is called the *North* or N-pole, and the other the *South* or S-pole. The difference between the two poles can be seen by taking two horseshoe magnets and placing their like poles and again their unlike poles together. It will be found that the *like* poles repel each other and the *unlike* poles attract each other. This is one of the fundamental laws of magnetism.

**95. Lines of Force.**—If a horseshoe magnet be placed on its side, as shown in Fig. 179A, a piece of paper put over it, and iron filings sprinkled over the paper it will be found that the filings arrange themselves in well defined lines. This arrangement indicates that there is a magnetic force acting between the two poles of the magnet. The influence which two horseshoe magnets (such as used on magnetos) have on each other, when laid side by side, is clearly shown in Fig. 179 B and C. In Fig. 179B two magnets are arranged in a vertical position to show the magnetic flux between the pole ends when properly assembled; while in, Fig. 179C, the magnets are incorrectly assembled, the North end of one magnet

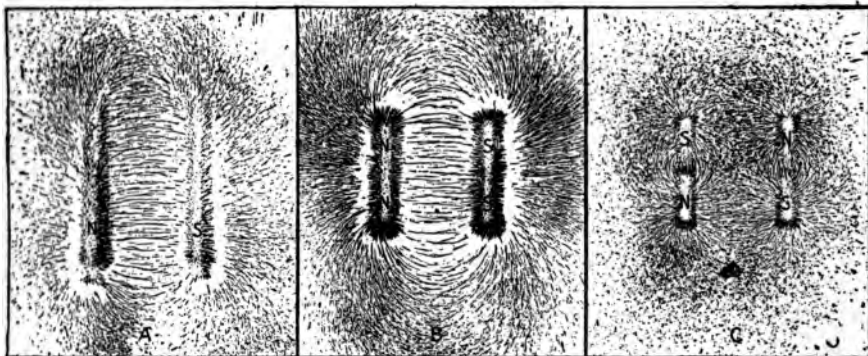

FIG. 179.—Magnetic field shown by iron filings.

lying next to the South end of the other, thereby greatly reducing the number of lines of force that would be cut by an armature rotating between the poles. In placing the magnets on a magneto, great care must be taken to get all the North poles together and all the South poles together. An easy way to make sure of this, before putting the magnets on the magneto, is to lay the magnets together so that the poles will repel each other.

**96. Types of Magnets.**—In some types of magnetos, compound permanent magnets are used. A compound magnet is one built up of several simple magnets arranged with like poles together as shown in Fig. 180C. Experience has proved that a compound magnet is much stronger than a simple magnet of the same size, and is, therefore, more desirable. The number of magnets required to produce the desired magnetic field strength depends to a great extent on both the kind and the quality of the steel used in the magnets. At the present time, chrome or tungsten

steel is most generally used, so that two magnets, arranged as shown in Fig. 180B, are usually found sufficient. It is generally recognized that the magnetic pull of each magnet should be able to sustain a weight of at least 15 lb. in order to give satisfactory service.

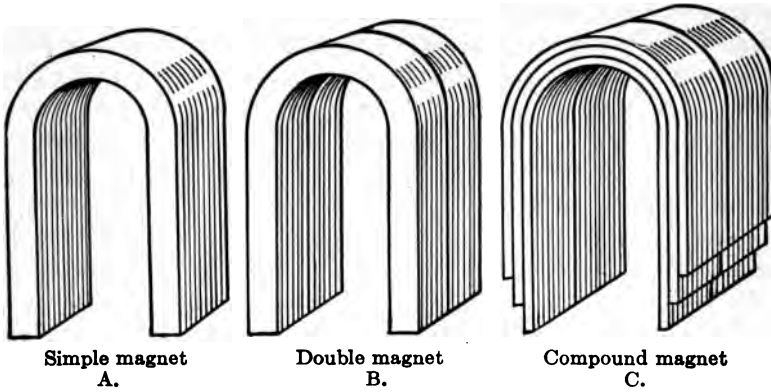

FIG. 180.

**97. Mechanical Generation of Current.**—It has been found that if a wire be moved across the magnetic field between the poles of a magnet so as to cut the *lines of force*, there will be an electric current generated in the wire. If the wire should then be moved across the lines of force in the opposite direction, the current would again flow in the wire but in the opposite direction. The exact reason for this is unknown, but it is a well-known fact that cutting magnetic lines of force by moving a wire across them will generate current in the wire. The process of generating a current in this manner is known as *induction*, and the current thus produced is termed an *induced current*.

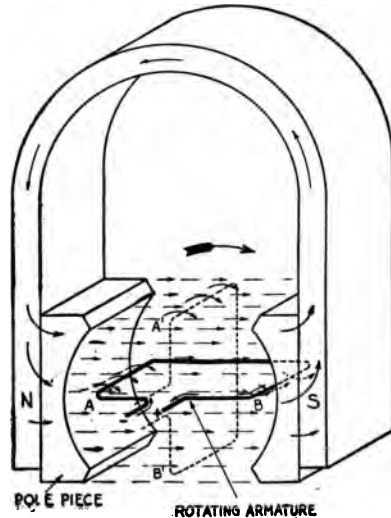

FIG. 181.—Mechanical generation of current.

The fact that current can be generated through induction is made use of in the magneto, an elementary type of which is shown in Fig. 181. The wire is formed in the shape of a rectangle and arranged to rotate between the pole pieces of the magnet. If the ends of the wire are connected by a measuring instrument, a current of electricity will be found to flow out of one end of the wire and into the other end as the wire is revolved. In the position shown, with the loop rotating in a clockwise



direction, the current will flow out at *B* and in at *A*. If the loop of wire is turned through a complete revolution, it will be found that the current generated will alternate in direction, making one complete reversal in one revolution of the wire. This is due to the wire cutting the magnetic lines of force first in one direction, and then in the other. When the wire is cutting the lines of force at right angles, the voltage is the maximum, and it is at this period of rotation that the current is best for ignition purposes. This condition occurs twice during a complete revolution of the loop of wire. *A-B* represents the position of maximum induced voltage, and *A'-B'* the point of no induced voltage since at this point the wire is travelling parallel to the lines of force and is, therefore, not cutting them. After passing the vertical position, the side of the loop *A* will cut the magnetic lines of force in the opposite direction, causing the induced current in the wire to reverse, flowing out at *A* instead of at *B*.

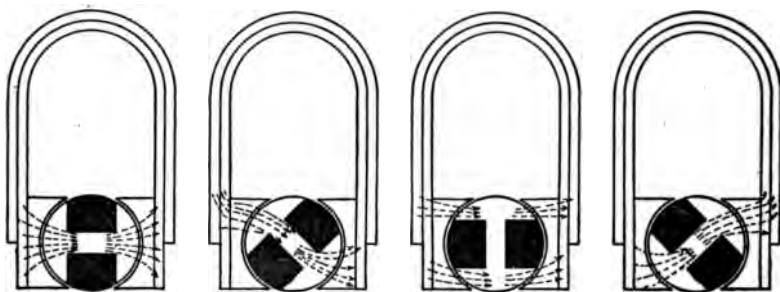

FIG. 182.—Change of magnetic field through H-type armature.

In the actual magneto, instead of having only one turn of wire, a great many turns of wire are wound in the shape of a coil around a piece of laminated iron, called the *armature core*. This coil is caused to rotate between the magnetic poles, thus generating a current. Figure 182 illustrates the change and cutting of the magnetic lines of force during one complete revolution of the armature. By using the laminated iron armature core, the strength of the magnetism between the poles of the magnet is increased, thus increasing the number of lines of force that are cut by the coils of wire.

**98. Low-and High-tension Magnetos.**—A *low-tension* magneto is one which delivers current of a low voltage. This current must be converted to the necessary high voltage for ignition by an external *induction* or *transformer* coil. The armature contains only a primary winding, while the transformer coil has the usual primary and secondary windings.

A *high-tension* magneto delivers current from the armature at sufficiently high voltage for ignition, without the use of an external transformer coil. The high-tension current is generated in a high-tension

winding on the armature of the magneto. The armature assembly also contains the primary winding and the condenser. The true high-tension magneto must not be confused with the so-called high-tension magneto in which the armature current is transformed by a coil placed in the top of the magneto, instead of outside as is done in the low-tension type. The coil is contained in the magneto assembly merely for convenience, but this does not make it a high-tension magneto in the correct sense of the term.

**99. Armature and Inductor Type Magnetos.**—An *armature* or *shuttle wound type* magneto is one in which the lines of force are cut by means of a coil of wire wound on an armature or *shuttle* rotating between the magnetic pole pieces as just described. It may be of either the high- or low-tension type.

In an *inductor* type magneto, the coil of wire is stationary. The cutting of the lines of force by the stationary coil is caused by a revolving *inductor*. Since the coil in which the current is generated is stationary,

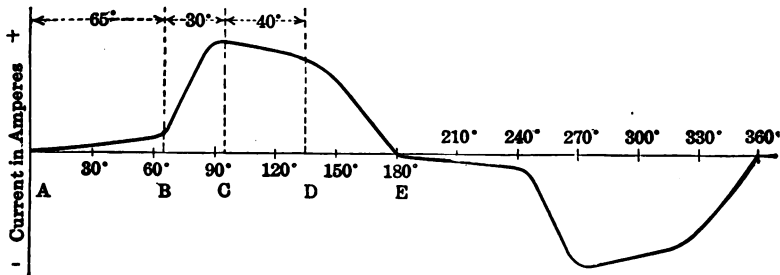

FIG. 183.—Typical curve of current from shuttle armature.

this avoids the necessity of having sliding contacts and brushes in order to connect the coil with the external circuit. The inductor type magneto may also be either low- or high-tension. The constructional features of these two general types will be pointed out in considering the several types of modern magnetos.

**100. Current Wave from a Shuttle Wound Armature.**—Figure 183 shows a typical curve of the current generated in the winding of a shuttle wound armature as it turns through one revolution. In Fig. 184 are shown the positions of the armature corresponding to the points, *A*, *B*, *C*, *D*, and *E* of Fig. 183. In position *A* the flux is passing through the armature in one direction while in position *E*, after turning  $180^\circ$ , the flux is in the other direction, because the armature has turned around. During the remainder of the revolution, from position *E* around to position *A*, the current generated will be opposite in direction to that generated during the first half of the revolution. The current generated during the first half of the revolution is shown in Fig. 183 by the height of the curve above the base line, while that generated during the second half is shown below the line.

The exact positions of the armature at which the strongest electrical impulses can be obtained, and also the shape of the current wave, depend upon the forms of the pole pieces and the armature core, as well as upon the speed of rotation and the strength of the magnets. Any change in one of these factors will produce a change in the electrical pressure at the terminals of the armature winding.

Most magnetos that are run at variable speeds are constructed so that a strong current can be produced throughout a considerable range of position of the armature. This is done to allow for the advance and retard of ignition relative to the position of the pistons, as well as to allow for the lag of the current in the armature with regard to the position of the armature at the instant of maximum impulse or voltage. This current lag for the speeds in usual practice is small, so that in general the positions of the armature for the maximum current are as indicated in Fig. 183 and Fig. 184.

**101. Magneto Speeds.**—It is evident from the current wave diagram of Fig. 183 that, whatever the system of ignition with which a low-tension magneto is used, the best spark will be produced only during the angle of

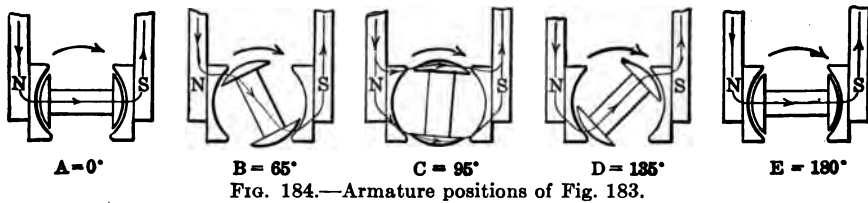

rotation in which the current generated is at or near its maximum. When the armature is in position *C*, Fig. 184, the current is at its maximum and the spark is strongest. As the armature rotates from position *C* to *D* the curve, Fig. 183, is near its maximum height; hence, during this period the current produced is most favorable for ignition purposes. Position *C* would correspond to extreme advance and *D* to extreme retard for this magneto, giving a spark range of about 40° of armature rotation. It is evident from the shape of the curve that a position of advance beyond *C* or of retard beyond *D* would give a spark too weak for ignition purposes or no spark at all. This shows the necessity of having an alternating current magneto gear-driven from the engine shaft, so that the armature will always be in the proper position with relation to the engine pistons. The curve of Fig. 183 also shows that there are two points in a revolution of this type of armature during which a spark can be obtained, namely, between *C* and *D* as just mentioned and at a similar position 180° later, when the current is in the other direction. Consequently, the magneto with an H type or shuttle wound armature, ordinarily used for automobile ignition, gives two sparks per revolution of its armature. Because of this,

the armature speed of a magneto must have a definite relation to the number of cylinders of the engine. In a four-cylinder four-stroke engine the armature must revolve at crankshaft speed in order to produce four sparks during two revolutions of the engine crankshaft. On a six-cylinder four-stroke engine the armature must make three revolutions during two revolutions of the crankshaft, or it must turn at one and one-half times crankshaft speed.

**102. Low-tension Magneto Ignition System with Interrupted Primary Current.**—In this type of ignition system, the current is supplied at low voltage by a low-tension magneto and is stepped up to a high voltage by an induction coil similar to the non-vibrating coil used with a battery

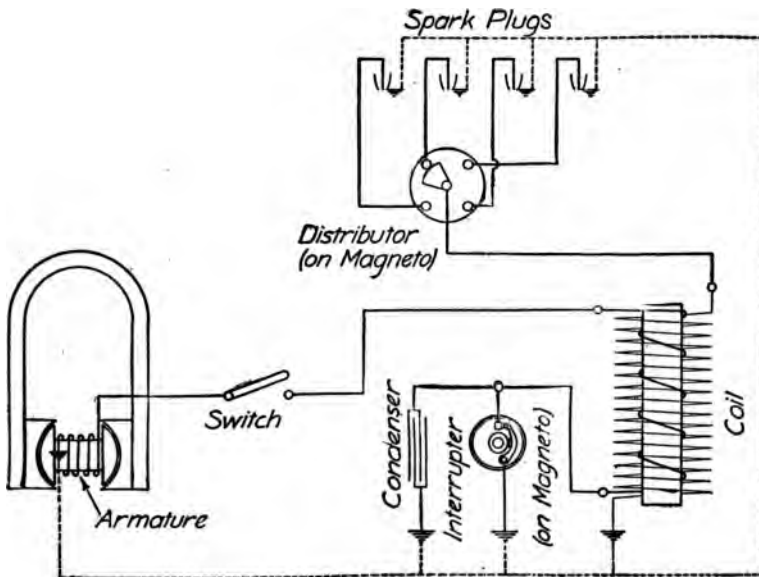

FIG. 185.—Low-tension magneto ignition system with interrupted primary current.

ignition system. The mechanical interrupter for the primary or low-tension current, and the distributor for the high-tension current, are provided on the magneto. Figure 185 shows this system in its simplest form. A magneto with a shuttle wound armature is shown, although a magnet of the inductor type could be used as well. One end of the armature winding is grounded to the metal of the armature as is usual in magnetic construction. The current is collected from the other end of the winding by a collector ring and brush which are not shown. The interrupter is shown separate, but it is always mounted on the magneto shaft so that the time of opening the circuit is in proper time with the period of greatest current flow in the armature winding. Assuming the interrupter contacts to be closed, the low-tension current generated in

the armature winding flows through the switch and the primary winding of the coil and through the interrupter to the ground (on the armature shaft) and back into the armature winding. During the next half revolution of the armature, the current in the circuit is in the reverse direction. At the desired time for the spark, which must be during the period of maximum current flow, the primary circuit is broken at the interrupter. This is caused by the high point of the cam raising the interrupter lever from its contact with the fixed contact point. A condenser placed in parallel with the interrupter absorbs the induced current in the primary winding, caused by this sudden interruption of the current flow, and assists in rapidly breaking down the magnetism of the coil core, in the same manner as in a battery ignition system. By this action, a high-tension current is induced in the fine secondary winding of the coil. The distributor, which is mounted on the magneto, receives this current at its central connection and directs it to the proper plug.

The secondary winding of the coil, as shown, is entirely separate from the primary and has its own ground connection. This is not necessary as the two coils could be connected at their upper ends and the secondary ground be made through the armature to the grounded end of that winding. The connection to the distributor would then be made from the other end of the secondary winding.

Instead of having the switch in series with the armature, and the circuit through the coil and the interrupter, so that opening the switch breaks the circuit, the switch connection might be from the insulated side of the circuit to the ground. In this case, the circuit would be through the coil and the interrupter when the switch was open. When the switch was closed, the current would have a permanent and easy path to the ground and back into the armature, so that practically no current would flow through the coil and the interrupter. In this case, closing the switch would ground the primary current so that the coil would become inoperative and ignition would cease.

The interrupter cam has two lobes corresponding to the two current waves produced per revolution in the shuttle type of armature and also in some magnetos of the indicator type. This arrangement is used when the number of cylinders is such that each current wave can be used for the production of a spark, and is common for four- and six-cylinder engines.

**103. Low-tension Magneto Ignition System with Interrupted Shunt Current.**—The interrupter in this system is not in series with the circuit through the primary winding of the coil, but is in a *shunt* or cross connection as shown in Fig. 186. This system is the one commonly used when a low-tension magneto is employed for ignition. The primary current has two possible paths, either through the interrupter,

if that is closed, or through the primary winding of the coil. The current naturally takes the easy path through the interrupter, when that is closed, there being practically no current through the coil at this time. When the magneto armature reaches the desired position for the spark, which is at some point during the period of maximum current flow, the interrupter is opened. This sudden interruption of the current through the shunt circuit, combined with the action of the condenser, produces an induced current in the armature circuit, and this, having no other path, rushes instantly through the primary winding of the coil. This sudden current through the primary winding induces a powerful momentary voltage in the secondary winding, and this voltage is used for the production of the spark at the plugs.

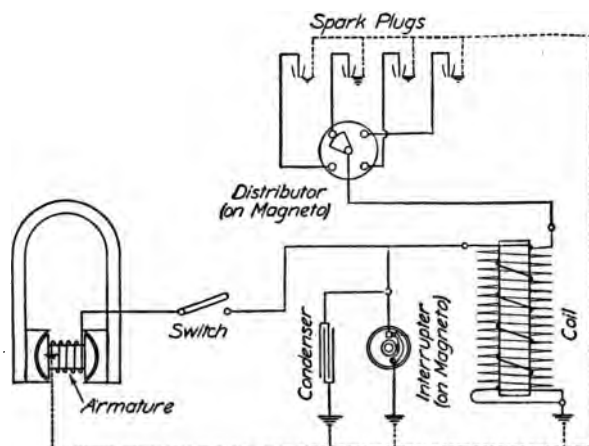

FIG. 186.—Low-tension magneto ignition system with interrupted shunt.

It will be noted that the spark from this type of magneto is produced by the building up of the magnetic field of the coil instead of by the breaking down of the field as in the interrupted primary system previously described. For this reason, and also because of the resemblance of its action to that of the ordinary transformer, the coil is sometimes called a *transformer coil*. An induced voltage is created in the secondary of any coil when the magnetic field is built up as well as when it is broken down. In battery ignition systems, however, the action of building up is comparatively slow, and the induced current is, therefore, not of sufficient voltage to be used. In the interrupted shunt type magneto, the coil winding of the armature, coupled with a condenser of proper capacity, produces, on the break of the shunt circuit by the interrupter, an impulse of current of sufficient power to magnetize the coil very rapidly and to give the desired induced voltage in the secondary winding.

After the armature has passed the position of maximum current, the interrupter is closed and the armature again has the easy shunt path through which to build up its current, when it again rotates into the position of maximum current.

As shown in the diagram of Fig. 186, the coil has a common ground connection for the two windings, making three terminal connections for the coil. The switch and coil are usually mounted as a unit on the dash. The collector brush on the magneto is connected to the switch on the coil. There is also a connection from the switch in the coil back to the insulated contact point on the interrupter and another connection from the primary winding of the coil back to a grounded binding post on the magneto frame. The secondary terminal of the coil is connected to the central post on the distributor. This makes

four connections when the switch is on the coil, although there are really only three coil connections. When a battery is used for starting purposes, another connection is added to the switch, and sometimes two if the one side of the battery is not grounded directly.



FIG. 187.—Splitdorf low-tension magneto, model T.

The condenser may be placed in the coil box or it may be built in the magneto. The switch may be placed in series with the connection from the armature to the coil and interrupter, as shown, or it may be arranged to ground the armature current permanently so as to short circuit the current from the coil and interrupter,

thus rendering them inoperative. In this latter connection, closing the switch cuts off the ignition current, while opening the switch permits the ignition to operate. A safety gap is also provided, either at the coil or at the magneto.

**104. Dual Ignition Systems.**—The majority of the low tension magnetos of the type just described are provided with an arrangement for using battery current for starting purposes when the magneto current is small, due to the low rotative speeds. The batteries can also be used for continuous running in cases of emergency, although the life of the batteries in this case is usually short because of the long contact at the interrupter, which wastes the battery current. The connections at the switch are usually made so that when the battery is used, the interrupter is in series between the battery and the coil; then the spark is induced by the interruption of the battery current through the coil.

In some of the dual systems, the switch is provided with a push-button operating a vibrator or interrupter in the battery circuit, so that a spark can be produced without turning the engine. This enables the operator to start the engine on the spark if there is an explosive charge in the cylinder.

**105. Splitdorf Low-tension Dual Ignition System with Type T Magneto.**—The Splitdorf low-tension magneto ignition system is a typical dual ignition system of the interrupted shunt current type. Figure 187 shows the model T magneto and Fig. 188 the circuit wiring of this magneto with the typical box type induction coil which is mounted on the dash. The magneto is of the armature wound type having

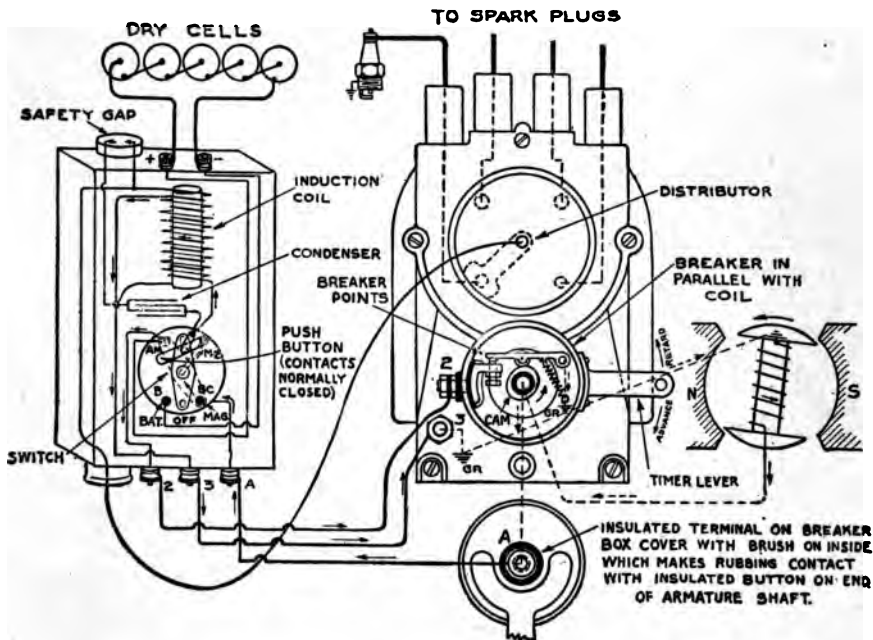

FIG. 188.—Wiring diagram of Splitdorf low-tension dual ignition system.

a single winding. The switch on the coil box has three positions, "Off," "Battery," and "Magneto." Figure 188 shows the switch dotted in on the "Magneto" position. The armature current is led from the collector brush A, which is mounted in the breaker cap and which rubs on an insulated button on the end of the armature shaft extending through the cam, to the coil box terminal A, and to the lower right switch button as indicated by the arrows. From there, the current has two paths back to the magneto ground. One path is by the way of No. 2 terminal over the breaker points which are normally closed; the other, through the primary winding of the coil to the grounded No. 3 magneto terminals. With the contacts closed, practically all of the primary



current will flow across the breaker points, owing to the fact that the resistance is much less than that through the primary coil winding. When the points open, this path is broken and there will be a sudden rush of current through the primary winding of the coil. The action of the primary current combined with the discharge from the condenser induces a high-tension current in the secondary winding of the coil. This high-tension current is directed to the proper plug by the distributor on the magneto. A safety gap is provided on the top of the coil box.

With the switch on the "Battery" position the magneto is disconnected and the dry cells connected to the primary circuits. When the system is operating on the battery, the coil and the breaker are in series and the system operates as an interrupted primary current system. The secondary circuit will be the same as when operating on the magneto, namely, from the high-tension terminal on the coil to the distributor, to the plug, to the ground, and returning to the secondary winding over the primary wire connected to No. 3 grounded terminal.

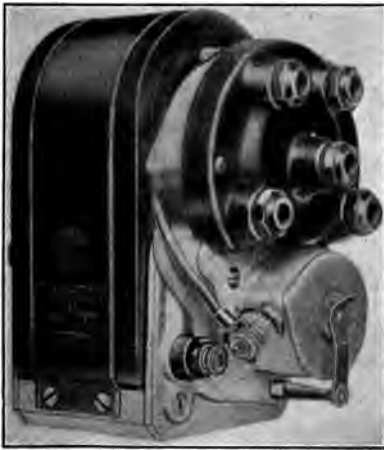

FIG. 189.—Remy magneto, model RL.

The condenser is mounted in the coil and is connected so as to protect both the magneto interrupter points and the push-button contacts on the switch.

The push-button contacts are in the primary circuit in series with the coil and are normally closed. When the switch is thrown on "Battery"

position and the breaker points are closed (which they normally are when the engine is at a standstill), the primary circuit will be completed and the coil magnetized by current from the dry cells. If the push-button is pressed and the contacts opened, the primary current will be interrupted, causing a sudden demagnetizing of the coil and creating a secondary spark in the cylinder which is lined up to fire in accordance with the position of the distributor arm. If the cylinder should contain a combustible mixture, it is possible that a spark caused in this manner would ignite the mixture and create sufficient explosive pressure to kick the engine over, causing it to start without the usual cranking.

**106. Remy Inductor Type Magneto.**—The Remy magneto, model RL, as shown in Fig. 189, is a typical low-tension magneto of the inductor type. Figure 190 shows the inductor and coil, while Fig. 191 shows the coil and the shaft in their places with respect to the pole pieces, the mag-

nets and the shaft bearings having been removed. The two wing-shaped inductors are mounted on a steel shaft and are revolved on either side of the stationary coil. Figure 192 shows the path of the magnetism during one complete revolution of the inductor.

When the inductors are in the horizontal position, the flux enters one inductor, makes a right-angled turn, passes along the shaft and through the coil to the other inductor and then to the other pole piece. In this position the same condition exists as when an armature of the

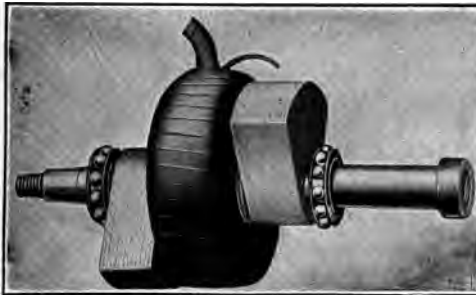

FIG. 190.—Remy inductors and stationary coil.

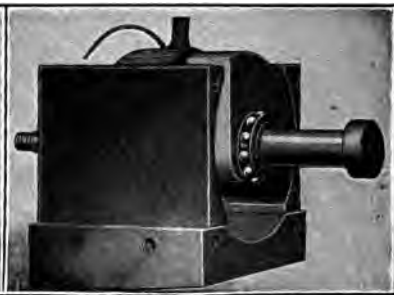

FIG. 191.—Remy inductor shaft and coil assembled in pole pieces and base.

shuttle type is in the horizontal position. When the inductors are revolved to the vertical position, the flux passes from one pole piece directly across through the inductors to the other pole piece, and there is no flux through the coil. This change, therefore, produces a voltage in the coil winding. The outer ends of the inductors are of such length that when they are in the vertical position, they offer a direct path from one pole piece to the other, but when they are horizontal, the flux must enter the

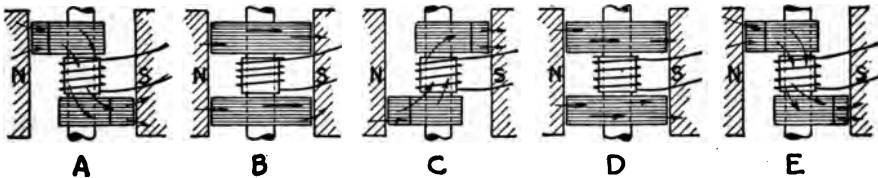

FIG. 192.—Path of magnetic flux through Remy inductor during one revolution.

one inductor, pass through the center of the coil, and out through the other inductor.

This magneto will produce two current waves per revolution in the same manner as the shuttle type. The current produced is also an alternating current as the direction of the flux through the coil is reversed each 180° of revolution of the shaft. Due to the design of the parts, the current wave has an abrupt rise and fall with an almost flat top, making possible a large timing range (35°) with practically the same

intensity of spark. This magneto is used for jump-spark ignition, the low-tension current generated in the coil being used with a circuit breaker and a step-up transformer coil. The secondary current from the transformer is led to a distributor on the magneto and is there distributed to the different plugs of the engine. The circuit breaker, Fig. 193, is mounted on the magneto and operated by a cam on the end of the arma-

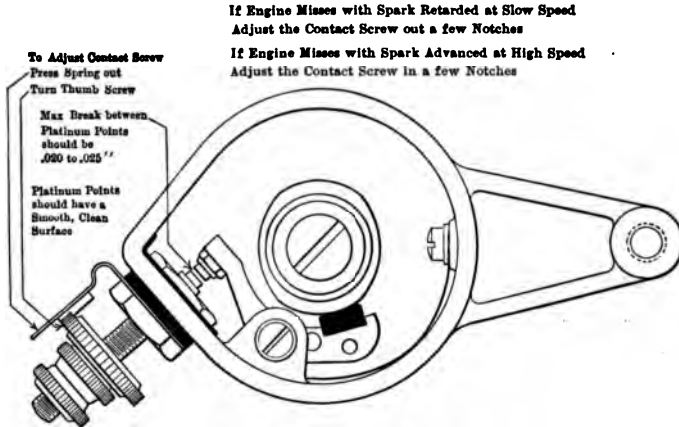

FIG. 193.—Circuit breaker of Remy magneto.

ture shaft, the cam being mounted so as to break the circuit in proper relation to the position of the armature for maximum current. The condenser, Fig. 194, is mounted in the arch of the magnets and is connected directly across the breaker points.

Figure 195 shows an external wiring diagram of the model RL magneto with type LE switch and coil, while Fig. 196 shows a diagram of the internal circuits. The lettering, *R*, *Y*, and *G*, on the coil indicates the color of the wire intended by the manufacturer to be connected to that terminal. The wiring from the coil to the magneto is connected as follows:



FIG. 194.—Condenser for Remy model RL magneto.

Red *R* wire goes to ground binding post on timer end bearing.

Yellow *Y* wire goes to contact screw

post on circuit breaker.

Green *G* wire goes to insulated screw post on the timer end bearing.

*Timing.*—For timing this magneto, the engine should be turned over with the crank until No. 1 piston reaches top dead center on compression stroke. The timing button at the top of the distributor should be pressed in and the magneto shaft turned until the plunger of the timing button

is felt to drop into the recess on the distributor gear. With the magneto in this position it should be coupled to the engine. No attention should be paid to the circuit breaker when coupling or setting gears as the breaker is automatically brought into the correct position, and the dis-

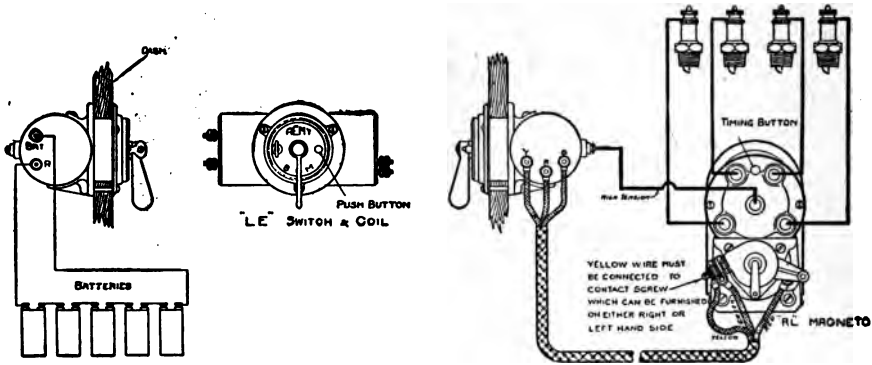

FIG. 195.—External wiring diagram of Remy magneto, model RL.

tributor segment is in contact with No. 1 terminal. This No. 1 terminal is plainly marked on the distributor.

**107. The Ford Ignition System.**—The Ford magneto may be classed as a high-frequency, alternating current magneto of the inductor type.

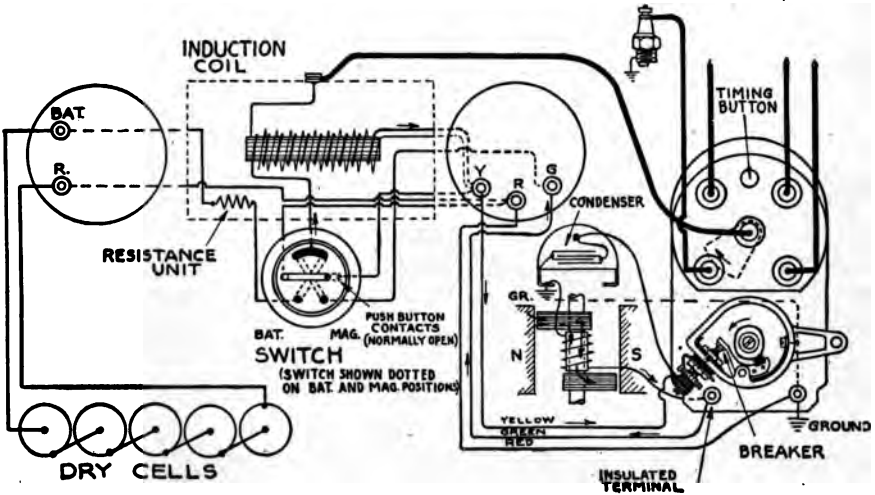

FIG. 196.—Internal circuit diagram of Remy magneto, model RL.

It serves merely as the source of primary current for an ordinary vibrating coil type of ignition system. The construction of the magneto is shown in Fig. 197 and Fig. 198, while the wiring diagram is shown in Fig. 199.

The stationary and revolving elements are interchanged from the

customary relation. The armature coils are stationary and the magnets revolve. The armature consists of 16 coils which are attached to a stationary supporting disc in the flywheel housing. An equal number of

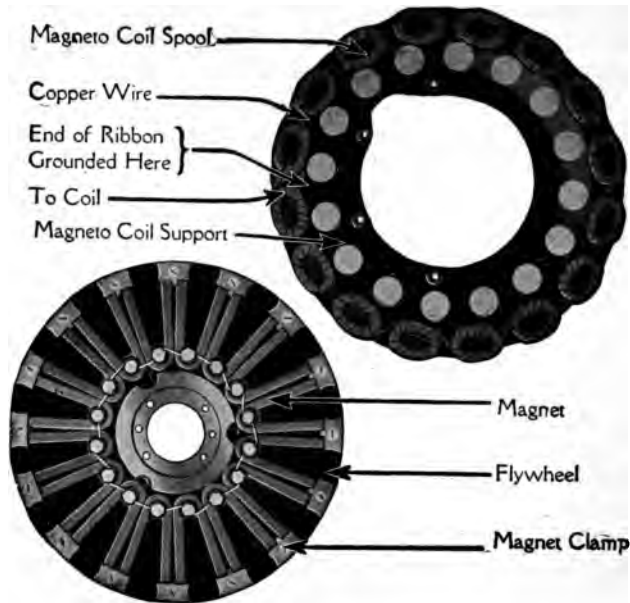

FIG. 197.—The Ford magneto.

permanent magnets of the horseshoe or V type are secured to the flywheel through non-magnetic studs. The magnets revolve with the flywheel at a

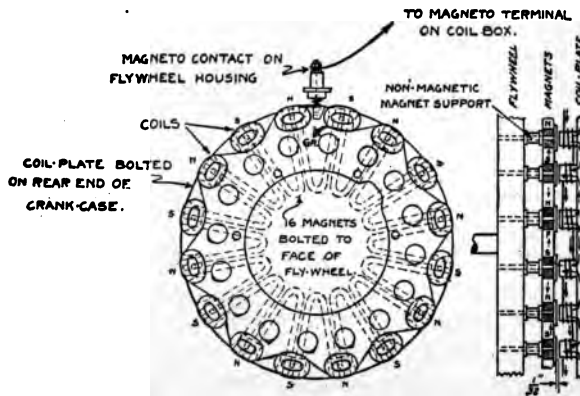

FIG. 198.—Diagram showing scheme of Ford magneto.

distance of  $\frac{1}{32}$  in. from the coils. The North poles of two adjacent magnets are fastened together, likewise the next pair of South poles. When a pair of North poles is in front of the core of one of the coils,

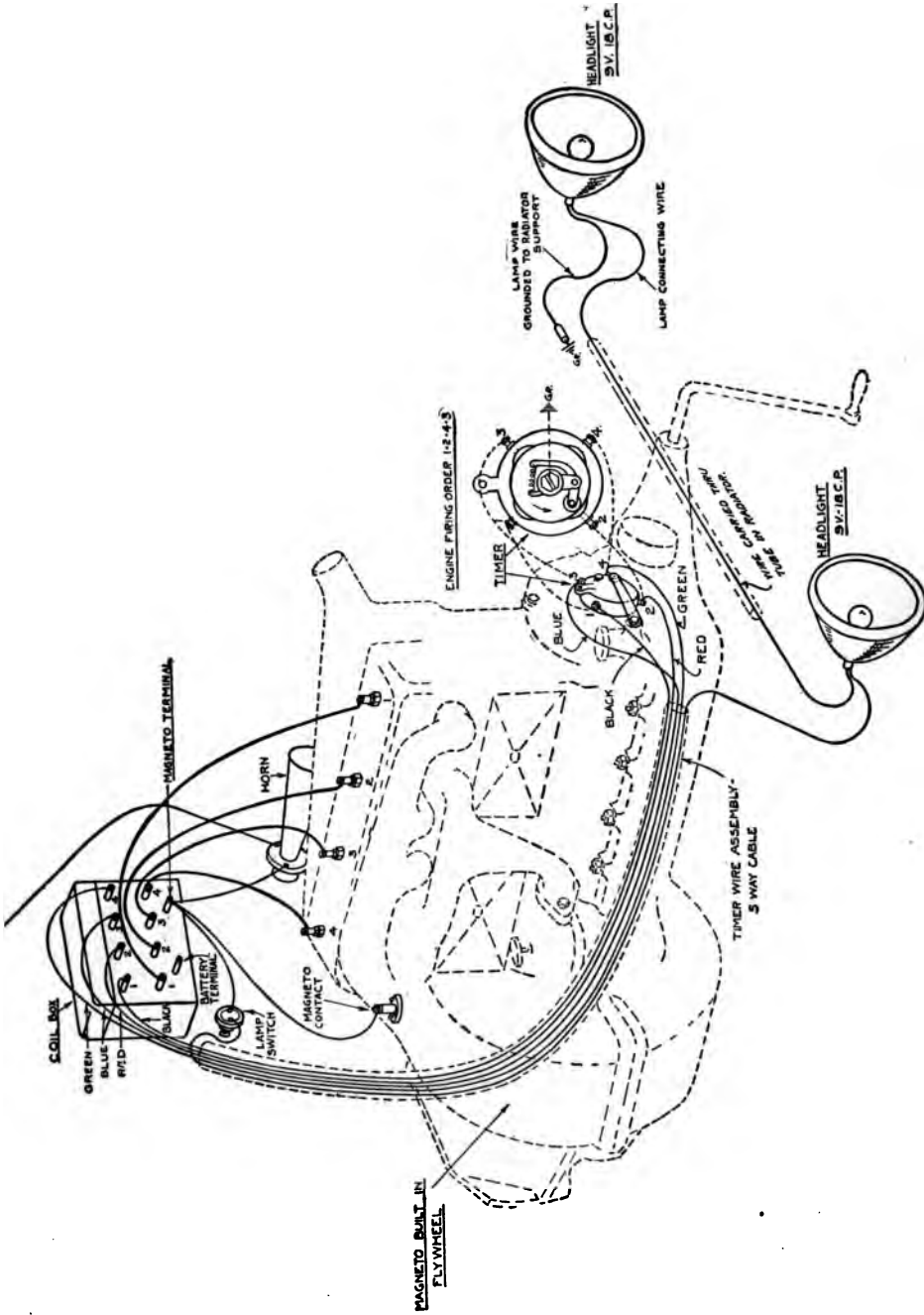

Fig. 199.—Wiring diagram of Ford ignition and lighting system.

the magnetic flux will flow in through the core, through the supporting coil plate, and out through the core of the adjacent coils to the South poles as shown in Fig. 198. When the flywheel makes  $\frac{1}{16}$  revolution, this flow is reversed. Thus, 16 current waves are generated per revolution of the flywheel. The coils are all connected in series with one end of the winding grounded and the other end connected to an insulated binding post on the outside of the flywheel housing. This post is connected to all four induction coils through a contact plate in the bottom of the coil box. The other ends of these coils are connected to the four posts of the timer mounted on the front end of the camshaft. Since one end of the magneto winding is grounded, and since the timer completes the circuit to the ground from each induction coil in proper order, it follows that the magneto current will pass through whichever induction

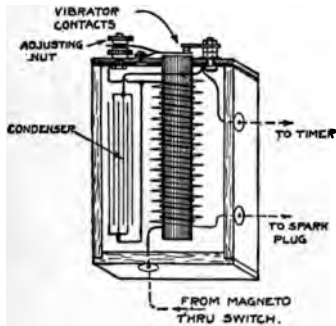

FIG. 200.—Diagram of Heinze-Ford induction coil.

coil is grounded at the timer. The induction coils are of the ordinary double wound induction type with vibrators to interrupt the primary current from the magneto. A diagram of the Heinze-Ford coil is shown in Fig. 200. The secondary of each coil has a direct connection to the plug of one of the cylinders with a grounded return.

#### 108. Timing the Ford Ignition System.

The magneto is quite unlike those previously described in that the current waves are of high frequency and are not all used for ignition. The magneto itself does not have to be timed to the engine. The alternations of the magneto current are frequent enough to cause only a slight variation in the instant of ignition as affected by the periods of no current. The length of contact in the timer is sufficient to overlap from one current wave to the next. In case the magnet is in a position where no current is generated when the timer first makes contact, there will be a lag of a very few degrees in the spark until the magneto has turned into a position where it will generate sufficient current to operate the coil. Due to the shape of the current waves, the greatest possible lag due to this cause is probably not more than  $5^\circ$  on the engine crankshaft. The actual timing of this system is all done at the timer. The roller in the timer is set so that it will be just making contact with the timer segment of cylinder No. 1 when the piston in that cylinder is  $\frac{1}{8}$  in. below top dead center on the working stroke and the spark control lever on the steering wheel is fully retarded.

## CHAPTER VII

### MODERN HIGH-TENSION MAGNETOS—ARMATURE TYPES

**109. The High-tension Magneto.**—Under the name of high-tension magneto are included all magnetos which generate, directly in the magneto winding, a current of sufficiently high voltage for jump-spark ignition without the aid of a separate induction coil. The magneto winding contains both a primary and a secondary winding, similar to the winding of a non-vibrating type induction coil, instead of the usual single winding found in the low-tension magneto. In the high-tension magneto is also

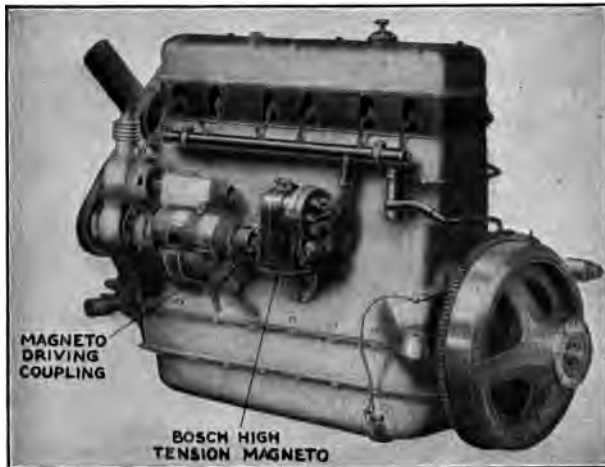

FIG. 201.—Bosch high-tension magneto installation on 1918 Marmon engine.

incorporated the interrupter, the distributor, and the condenser, so that the magneto contains within itself practically all the essentials of a complete ignition system, the only necessary outside parts being the spark plugs and the magneto controlling switch. This applies to both the armature wound and the inductor type of magneto.

**110. The Bosch High-tension Magneto.**—The Bosch magneto, Fig. 201 and Fig. 202, is a typical high-tension magneto of the armature wound type. The armature or rotating element, Fig. 203, is mounted on ball bearings supported in the end housings and rotates between the magnet pole pieces shown in Fig. 204. The armature, a cross section of which is shown in Fig. 205, consists of a soft iron core, a primary winding of comparatively few turns of coarse wire, a secondary winding of many turns



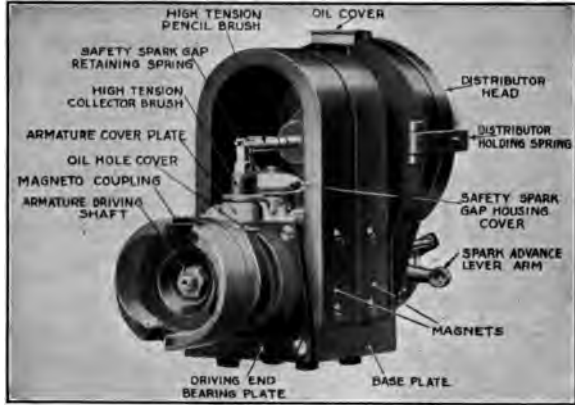

FIG. 202.—View of driving end of Bosch high-tension magneto.

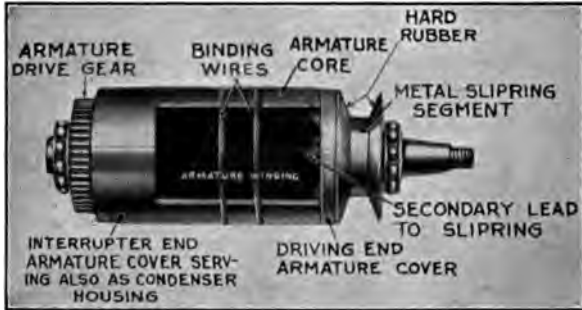

FIG. 203.—View of armature of Bosch DU4 high-tension magnetos showing ball bearing on armature shaft, and pinion that drives distributor gear.

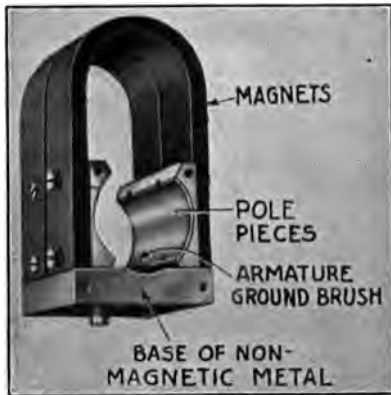

FIG. 204.—Magnets and pole pieces of Bosch magneto.

of fine wire wound on the outside of the primary, and a condenser. The condenser, Fig. 206, is mounted in one end of the armature housing and connected so as to protect the interrupter points, the interrupter or circuit breaker being mounted on one end of the armature shaft and revolving with it. The cams for actuating the interrupter points are

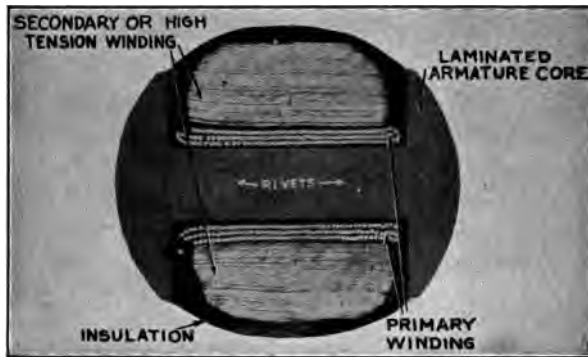

FIG. 205.—Cross sectional view of Bosch high-tension magneto armature.

on the inside of the interrupter housing. This arrangement is the reverse of that of the usual low-tension magneto which has the cam on the armature shaft and the interrupter in the housing. By having the interrupter, the condenser, and the primary winding all on the armature, the entire primary circuit is thus contained in the armature, forming a very com-



FIG. 206.—Condenser of Bosch DU4 high-tension magneto.

pact and efficient unit. One end of the primary winding is grounded on the armature core, and the live end brought out to a circuit breaking device. The grounded end of the secondary winding is connected to the live end of the primary winding so that one is a continuation of the other. The magneto armature core is grounded to the magneto base by the ground brush shown in Fig. 207.

During certain parts of the rotation of the armature the primary circuit is closed, and the variations in magnetic flux induce an electric current in the winding. When the current reaches a maximum, which will occur twice during each rotation of the armature, the primary circuit is broken, and the resulting collapse of the magnetic field in the armature

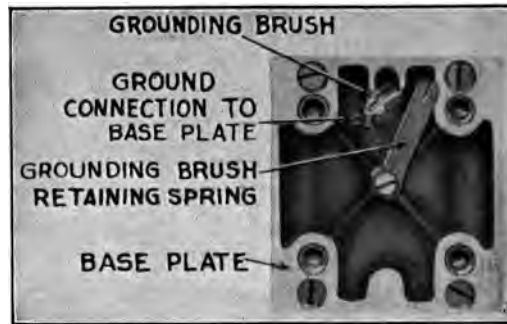

FIG. 207.—Bottom view of magneto base plate showing ground brush.

produces a high-tension current of extreme intensity in the secondary winding. This current is transmitted to the distributor through which it passes to the spark plugs in the cylinders in the proper order of firing.

The Bosch DU4 high-tension magneto is shown in Fig. 208, while a longitudinal section and the rear view with the breaker cover removed are shown in Fig. 209. Figure 210 is a circuit diagram for the magneto.



FIG. 208.—Bosch high-tension magneto, type DU4.

*Magneto Interrupter.*—The magneto interrupter mechanism is mounted on a circular disc which is held rigid to the armature shaft by the interrupter fastening screw. The relative position of the interrupter to the armature is fixed by a keyway in the end of the armature shaft which is taper bored. As may be seen in Fig. 210, the fastening screw also forms the electrical connection between the stationary (insulated) half of the interrupter and the primary winding of the armature.

This fastening screw also makes connection with the insulated terminal of the condenser, the other terminal of which is grounded as are also one end of the primary winding and the movable contact arm of the interrupter.

Twice during each revolution of the armature, the primary circuit closes and opens, this being caused by the fiber block on the interrupter

lever striking the two steel cams on the inside of the interrupter housing. When the interrupter is not being acted upon by the cams, the interrupter points are normally held closed by spring tension; consequently, the primary circuit is also closed. It is very important in this type of interrupter that the interrupter lever unit be very accurately balanced on its pivot to insure proper opening and closing of the points at high rotating speeds. The interrupter points are made of platinum and should be adjusted to open .012 in. to .015 in. on engines of normal compression.

*Principle of Operation.*—The function of the interrupter or breaker is to interrupt the circuit of the primary winding of the armature when a

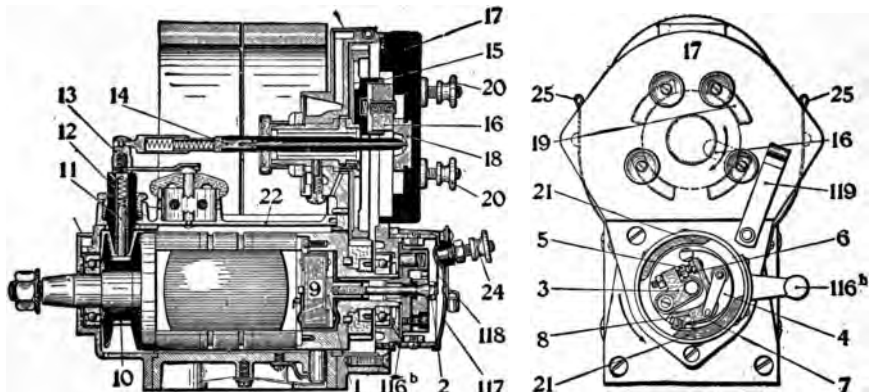

- |   |  |
|---|--|
| <p>Longitudinal section.</p> <ol style="list-style-type: none"> <li>1. Brass plate for connecting the end of the primary winding.</li> <li>2. Fastening screw for magneto interrupter.</li> <li>3. Contact block for magneto interrupter.</li> <li>4. Magneto interrupter disc.</li> <li>5. Long platinum screw.</li> <li>6. Short platinum screw.</li> <li>7. Flat spring for magneto interrupter lever.</li> <li>8. Magneto interrupter lever.</li> <li>9. Condenser.</li> <li>10. Collecting ring.</li> <li>11. Carbon brush.</li> <li>12. Brush holder for same.</li> <li>13. Terminal piece for conducting bar 14.</li> <li>14. Conducting bar.</li> </ol> | <p>Rear end interrupter cover removed.</p> <ol style="list-style-type: none"> <li>15. Distributor brush holder.</li> <li>16. Distributor carbon brush.</li> <li>17. Distributor plate.</li> <li>18. Central distributor contact.</li> <li>19. Brass segment.</li> <li>20. Knurled nut on terminal stud.</li> <li>21. Steel cover.</li> <li>22. Dust cover.</li> <li>24. Knurled nut on grounding terminal stud</li> <li>25. Holding spring for distributor plate 17.</li> <li>116b. Interrupter housing and timing arm.</li> <li>117. Cover for interrupter housing.</li> <li>118. Conducting spring for grounding terminal stud.</li> <li>119. Holding spring for interrupter housing cover.</li> </ol> |
|---|--|

FIG. 209.—Construction of Bosch high-tension magneto, type DU4.

high-tension spark is to occur at the plug, the action in the armature being similar to that of an induction coil. This interruption must take place when the flow of current through the primary winding is at or near its maximum value, which occurs twice per revolution when the armature core is approximately in a vertical position, as shown in Fig. 210, the same as in the low-tension magneto. In this position, the corner of the armature is just leaving the corner of the pole piece and the winding is cutting the greatest number of magnetic lines of force. In Bosch magnetos, having a variable spark advance, the interrupter points are timed to open when the corner of the armature has left the corner of the pole piece about  $\frac{1}{16}$  in. with the interrupter housing in full advance position. The

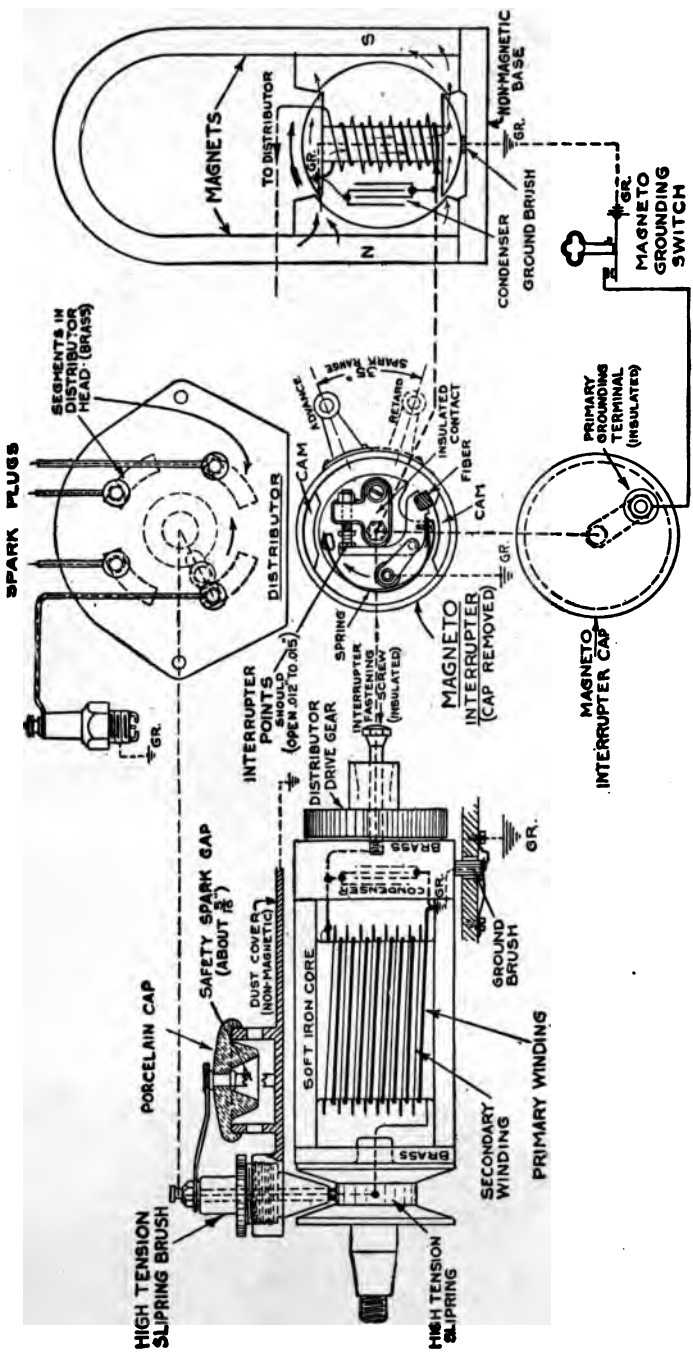

Fig. 210.—Circuit diagram of Bosch DU4 high-tension magneto.

timing lever may be advanced about  $35^\circ$ ; then, when the interrupter housing is fully retarded, the armature has passed the pole piece about  $\frac{3}{8}$  in. Thus the best spark is obtained with the interrupter in full advance position, which is the normal operating position at high engine speeds.

Figure 211 *A*, *B*, and *C* shows the distribution of the magnetic flux through the armature core for various armature positions. Owing to the rotation of both the primary and the secondary windings of the armature and the consequent cutting of the magnetic lines of force by both windings, a voltage is generated in both the primary and secondary circuits proportional to the number of turns in the two windings. During the period of rotation when the magnetic field is passing through the armature core, the interrupter points are closed, thus completing (by short circuiting)

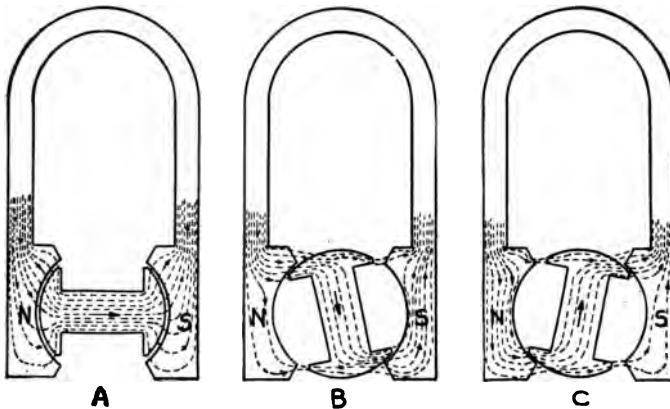

FIG. 211.—Distribution of magnetic flux through magneto armature core for various positions.

the circuit through the primary winding. The current thus generated in the primary winding will flow around the core, causing the core to become magnetized in a cross direction as shown in Fig. 212. At approximately the instant when the generated voltage is greatest, the interrupter breaks the primary circuit thus permitting the armature core to demagnetize instantly. This causes a high voltage to be induced in the secondary winding in the same direction as the generated voltage. The induced current produced by the interruption of the primary circuit lasts a very short interval of time and, if acting alone, would produce but a single flash at the spark plug. However, owing to the revolving of the secondary winding in the magnetic field, a more continuous current of not so high a voltage is generated. This generated voltage alone is not sufficient to break down the resistance of the gap in the spark plug, but at the instant the primary circuit is interrupted, the induced current is sufficient to break down this resistance and then the somewhat lower vol-

tage of the generated current is able to maintain the flow of current across the gap, thus producing, not an instantaneous flash, but a hot flame which lasts for a considerable period. The heat produced by this prolonged spark is much more intense than that produced by the short flash caused by the induced current.

*Condenser.*—The condenser, as in most high-tension armature type magnetos, is located in one end of the armature. It is connected in parallel with the primary winding and the interrupter circuit. As stated previously, the purpose of the condenser is to absorb the induced charge in the primary winding and prevent the discharge of this current across the interrupter points. The charge in the condenser surges back into the primary winding in the opposite direction to that of the primary

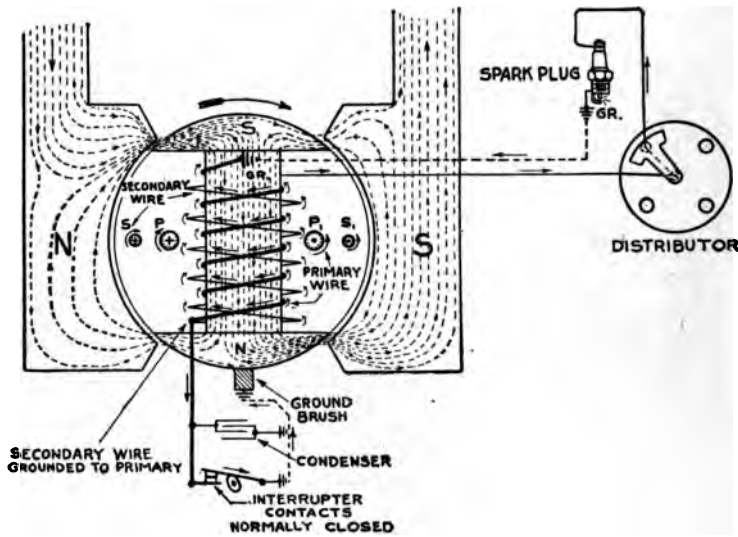

FIG. 212.—Diagram showing armature cross-magnetization due to current generated in primary and secondary winding.

current, thereby causing a more rapid demagnetization of the armature and, consequently, producing a higher voltage in the secondary winding than would otherwise be obtained.

In the diagram shown in Fig. 210 it will be seen that one end of the secondary winding is connected to the insulated end of the primary winding so that the one forms a continuation of the other. The other end of the secondary winding leads to the collector ring or *slip ring* on which slides a carbon brush, insulated from the magneto frame. The secondary current is conducted from the brush to the center distributor contact and from there through the carbon brush (carried on the distributor gear wheel) to the various cable connections and spark plugs in their proper order of firing. After jumping the spark plug points, the current returns

through the engine frame and the ground brush in the base of the magneto, Fig. 207 and Fig. 210, to the armature core and back to the beginning of the secondary winding. As in the low-tension armature type of magneto, there are two sparks produced per revolution of the armature. The distributor is, therefore, similar to that found on the low-tension magneto and is driven at similar speeds. The only difference is that the secondary current is received direct from the armature instead of being brought back to the distributor from a transformer coil. The distributor has as many segments as there are engine cylinders and is driven at one-half the speed of the crankshaft. For a four-cylinder engine the distributor has four segments and is driven at one-half the speed of the armature. For a six-cylinder engine there are six segments, and the distributor

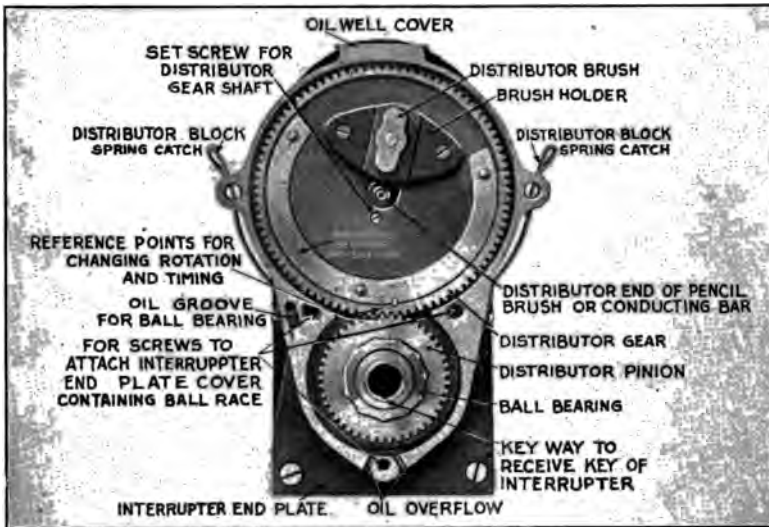

FIG. 213.—Bosch distributor gears showing markings for timing distributor with armature.

arm is driven at one-third the speed of the armature. The relations of magneto speeds to engine speeds are also the same as for the armature type of low-tension magnetos. For a four-cylinder four-stroke engine the armature revolves at crankshaft speed. For a six-cylinder four-stroke engine the armature revolves at one and one-half times crankshaft speed. Likewise, for an eight- or twelve-cylinder engine a magneto of this type must be driven at twice or three times crankshaft speed, respectively, in order to produce the required number of sparks per revolution of the engine.

Care should be taken in assembling the magneto to get the distributor gear timed correctly with the armature so that the distributor brush will be in proper alignment with the distributor head segment when the interrupter points open with the breaker housing in either the advance or



retard positions. On full advance position, the distributor brush should be moving on to the distributor head segment when the interrupter contacts open, and should be leaving the same segment when the contacts open with the breaker housing shifted to full retard position. Figure 213 shows the punch markings on the distributor gears for the purpose of timing the distributor with the armature. For a magneto having clockwise direction of rotation, the punch mark "C" on the distributor gear should mesh with the punch mark on the armature gear, while in the case of a magneto with anti-clockwise rotation, the gears should be meshed so that the punch mark "A" will mesh with the punch mark on the armature. The direction of armature rotation is usually indicated by an arrow stamped on the magneto housing near the driving end of the armature shaft.

*The Safety Spark Gap.*—In order to protect the insulation of the armature and of the current-conducting parts against excessive voltage, a safety spark gap of about  $\frac{5}{16}$  in. is provided as shown in Fig. 210. The current will pass through this gap in case a cable connection to one of the spark plugs becomes disconnected while the magneto is in operation, or if the electrodes on the spark plugs are too far apart. The secondary current should not be permitted to jump the safety gap for any length of time as the continued discharge of the current over the safety gap is liable to damage the magneto winding and the condenser.

*The Magneto Grounding Switch.*—In order to cut off the ignition without damaging the windings, the primary current must be short circuited so that it will not be interrupted when the interrupter points open. This is arranged for by connecting a wire from the insulated terminal on the breaker cover, to a simple ground switch which has two terminals, one of which connects to the engine or chassis frame. The terminal on the breaker cover is connected by a brush to the insulated half of the interrupter, so that when the switch is closed the primary current is short circuited through the switch and ground and the magneto ceases to generate sufficient voltage in the secondary winding to jump the spark plug points, thus preventing ignition.

**111. The Bosch High-tension Dual Ignition System.**—In the Bosch high-tension dual ignition system, the standard type of Bosch magneto is used with the application of two timers or interrupters. The parts of the regular current interrupter are carried on a disc that is attached to the armature and revolves with it, the rollers or segments that serve as cams being supported on the interrupter housing. In addition, the magneto is provided with a steel cam which is built into the interrupter disc, and has two projections. This cam acts on a lever supported by the interrupter housing, the lever being connected in the battery circuit so that it serves as a timer to control the flow of battery current. These parts may be seen in Fig. 214. A non-vibrating transformer coil is used with the battery current to produce the necessary voltage.

It is obvious that the sparking current from the battery and from the magneto cannot be led to the spark plugs at the same time, so a further change from the magneto of the independent form is found in the removal of the direct connection between the collecting ring and the distributor. The collecting ring brush shown in Fig. 215 as No. 3 is connected to the switch, and a second wire leads from the switch to the central terminal on the distributor. When the engine is running on the magneto, the sparking current that is induced in the secondary armature winding flows to the distributor by way of the switch contacts. When the engine is running on the battery, the primary circuit of the magneto is

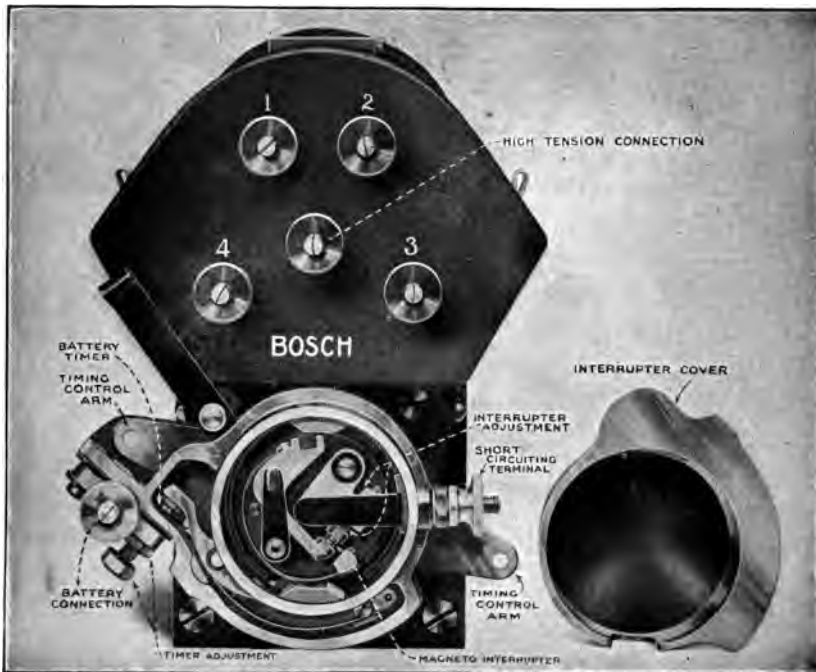

Fig. 214.—Bosch dual magneto showing magneto interrupter and battery timer.

grounded, and there is, therefore, no production of sparking current by the magneto. The sparking current from the coil then flows to the central distributor connection. It will be seen that the only parts of the magneto and battery circuits used in common are the distributor and the spark plugs.

*The Bosch Dual Coil.*—The Bosch dual coil used in the dual system is contained in a cylindrical housing with a brass casting on one end, the flange of which serves to attach the coil to a dashboard or other part. The coil is provided with a key and lock, by which the switch may be locked when in the "OFF" position. This is a point of great advantage, as it makes it unlikely that the switch will be left thrown

to the battery position when the engine is brought to a stop. The absence of such an attachment is responsible in a large measure for the accidental running down of the battery. This locking device also prevents the unauthorized operation of the engine. The parts of the coil are shown in Fig. 216. In addition to the housing and end plate, the parts consist of the coil itself, the stationary switch plate, and the connection protector.

When the engine is running on battery ignition, a single contact spark is secured at the instant when the battery interrupter breaks its circuit, and the intensity of this spark permits efficient operation of the engine on the battery system.

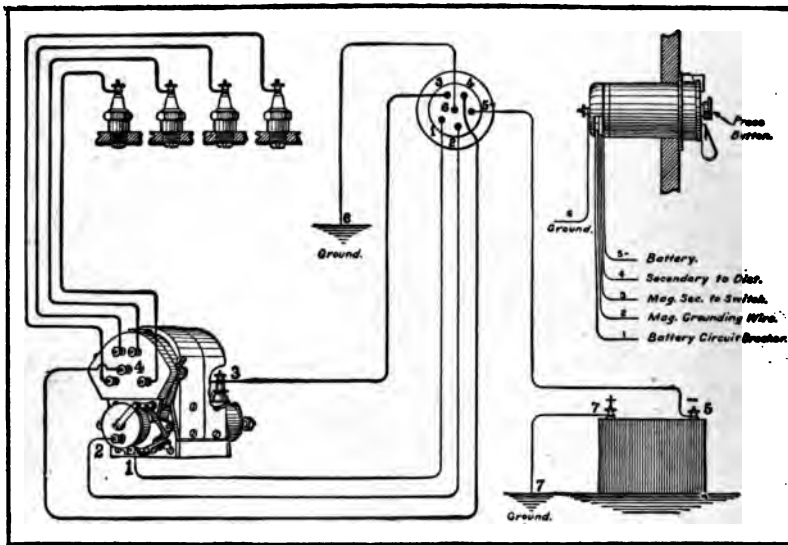

FIG. 215.—Wiring diagram for Bosch dual ignition system.

*Starting on the Spark.*—For the purpose of starting on the spark, a vibrator may be cut into the coil circuits by turning the button that is seen on the coil body in Fig. 215 and Fig. 216. Normally, this vibrator is out of circuit, but the turning of the button places it in the battery primary circuit. A vibrator spark of high frequency is thus produced.

It will be found that the distributor on the magneto is then in such a position that this vibrator spark is produced at the spark plug of the cylinder that is performing the power stroke. If a combustible mixture is present in this cylinder, ignition will result and the engine will start.

*Connections.*—In the wiring diagram of this system, as shown in Fig. 215, it will be noted that while the independent magneto requires

but one switch wire in addition to the cables between the distributor and spark plugs, the dual system requires four connections between the magneto and the switch; two of these are high tension, consisting of wire No. 3 by which the high-tension current from the magneto is led to the switch contact, and wire No. 4 by which the high-tension current from either the magneto or the coil goes to the distributor. Wire No. 1 is a low-tension wire conducting the battery current from the primary winding of the coil to the battery interrupter. Low-tension wire No. 2 is the grounding wire by which the primary circuit of the magneto is grounded when the switch is thrown to the "OFF" or to the "Battery" position. Wire No. 5 leads from the negative terminal of the battery to the coil, the positive terminal of the battery being grounded by wire No. 7. Wire No. 6 is a second ground wire connected to the coil terminal.

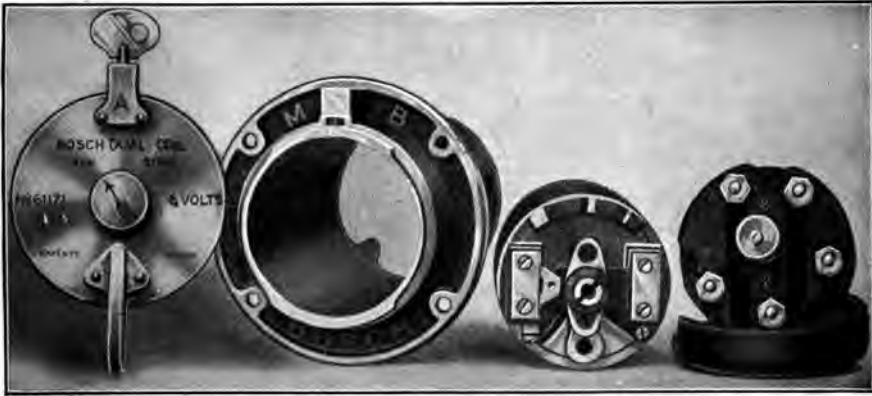

Fig. 216.—Parts of Bosch dual coil.

**112. The Bosch High-tension Magneto, Type NU4.**—The Bosch magneto, type NU4, Fig. 217, is of the high-tension, armature wound type and is suitable only for four-cylinder, four-cycle engines of the automobile type, rated at or under 30 horsepower. A distinct feature of this magneto is the absence of the usual gear-driven distributor, this being incorporated in the form of a double high-tension slip ring mounted on one end of the armature shaft as shown in Fig. 218. The magneto interrupter, Fig. 219, is the same as that used in the ordinary Bosch independent high-tension magneto.

A circuit diagram of this magneto is shown in Fig. 220A. It will be noted that the circuit of the primary winding is the same as for the Bosch DU4 shown in Fig. 210. The secondary winding, however, is not connected to the primary, its two ends being connected to the two metal segments in the slip ring mounted on the armature just inside of the driving shaft end plate of the magneto. The slip ring has

two grooves, each containing one of the two metal segments. These segments are set diametrically opposite on the armature shaft, that is,  $180^\circ$  apart, and are insulated from each other as well as from the armature core and magneto frame.



FIG. 217.

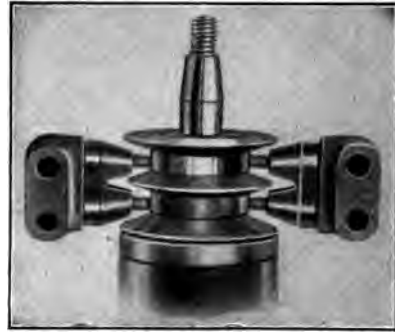

FIG. 218.

FIG. 217.—Bosch high-tension magneto, Type NU4.

FIG. 218.—Distributor on Bosch "NU4" magneto showing position of the carbon brushes with relation to the slip ring.

The four slip ring brushes which collect the secondary current are supported by two double brush holders, one on each side of the driving shaft end plate, each holder carrying two brushes so arranged that each brush bears against the slip ring in a separate groove. Upon rotation of the armature, the metal segment in one slip ring groove

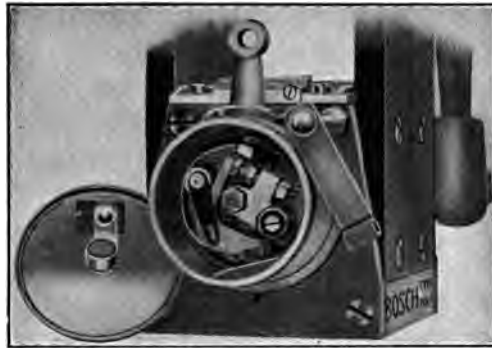

FIG. 219.—Interrupter end of Bosch "NU4" magneto.

makes contact with a brush on one side of the magneto at the same instant that the metal segment in the other slip ring groove comes into contact with a brush on the opposite side of the magneto. The marks "1" and "2" appearing in white on both brush holders indicate pairs of brushes receiving simultaneous contact, those marked "1" constituting one pair, and those marked "2," the other.

**113. Timing the Bosch Magneto, Type NU4.**—From the wiring diagram it is important to note that since two of the four slip ring brushes make contact simultaneously and each is connected by cable to the

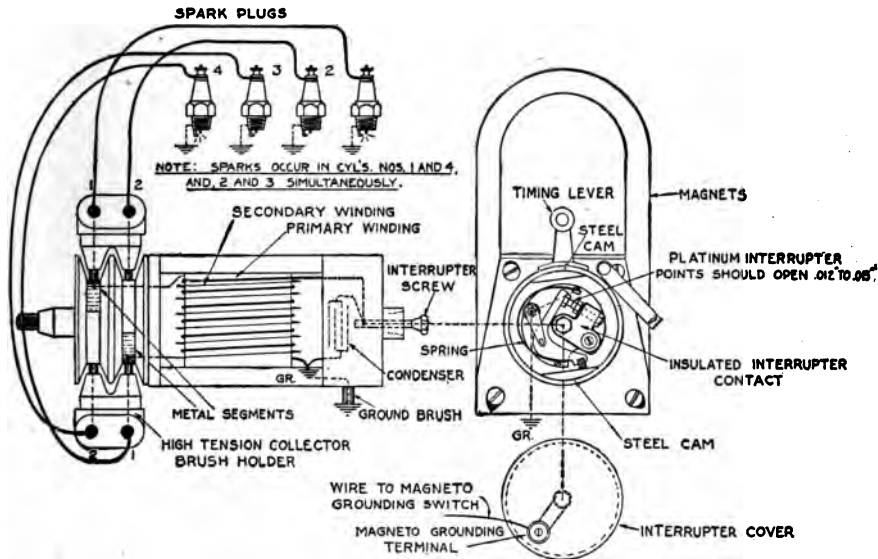

FIG. 220A.—Circuit diagram of Bosch "NU4" high-tension magneto.

spark plug in one of the cylinders, the secondary circuit always includes two plugs, the sparks occurring in two cylinders at the same time, namely, cylinders Nos. 1 and 4 or Nos. 2 and 3. Only one of these sparks, if properly timed, will cause ignition since in a four-cylinder engine, when No. 1 cylinder is under compression ready for ignition, No. 4 piston is finishing its exhaust stroke and the cylinder contains nothing but burned exhaust gases. The same relation exists when each cylinder is ready for ignition, the other cylinder in which the spark occurs containing non-combustible exhaust gases. Care should be taken in timing this type of magneto so that when fully retarded the spark will not occur in the dead cylinder after the intake valve has opened, which is usually a crank angle of about 8° to 10° past upper dead center. The platinum interrupter points should be adjusted to open .015 in., while the spark plugs should be adjusted to a gap of .020 in. to .030 in., or the thickness of a worn dime.



FIG. 220B.—Bosch high-tension magneto, type B.

*Bosch High-tension Magneto, Type B.*—The Bosch type B magneto, Fig. 220B, is a late product of the Bosch Magneto Company and is fitted to many engines made later than the spring of 1920. The type B magneto is equal, electrically and mechanically, to any of the Bosch types which have preceded. Moreover, it is simple in construction

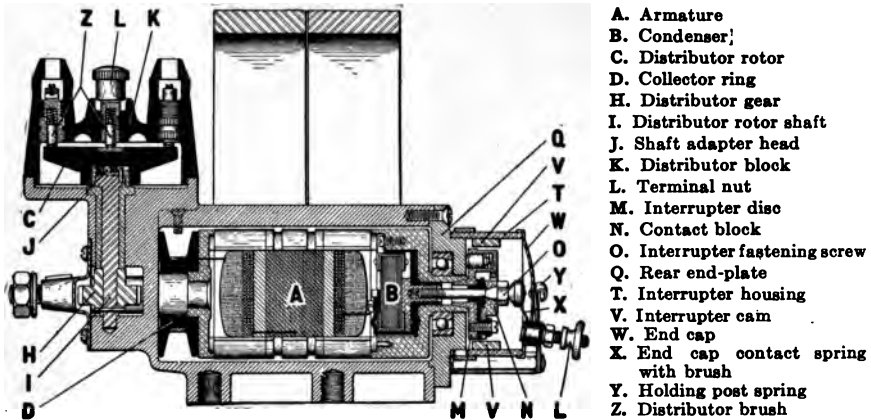

FIG. 220C.—Vertical section of Bosch type B magneto.

and can be manufactured and kept in adjustment very easily. The frame of this magneto is made of cast aluminum and includes the magneto base and the shaft end plate. The armature and the interrupter are of the regular Bosch construction.



FIG 221.—Eisemann high-tension magneto, Type G4, II edition.

The distributor, instead of being mounted over the interrupter housing, is located at the drive end of the magneto. It is mounted at the top of a vertical shaft driven by spiral gears from the armature shaft as shown in Fig. 220C. This construction gives a vertical distributor similar to those on battery ignition units.

This magneto is also made up in a special form for tractor use and is known as the type BT, which is in all respects similar to the type B magneto except that it is provided with the Bosch adjustable impulse coupling enclosed in a dust- and waterproof case.

**114. The Eisemann High-tension Magneto, Type G4.**—The Eisemann high-tension magneto, type G4, Fig. 221, is typical of the various models of the Eisemann magneto. It is made in two types known as G4, I Edition, and G4, II Edition. The principal differences between

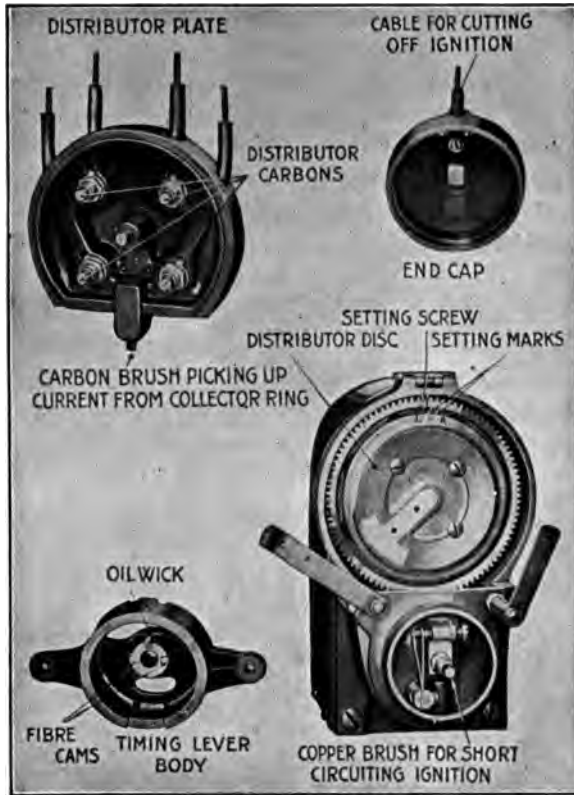

FIG. 222.—Principal parts of Eisemann high-tension magneto, type G4, I Edition.



FIG. 223.—Eisemann magneto, type G4, I Edition, with distributor removed showing setting marks for timing, also method of adjusting interrupter contacts.



the two models are in the design of the interrupter mechanism and in the construction of the armature housing.

In the type G4, I Edition, shown in Fig. 222, the movable contact of the interrupter is carried on a flat spring instead of on the usual rocking type lever. The interrupter points are actuated by this spring's striking the two fiber cams on either side of the center part of the timing lever body. The fixed end of the spring is grounded to the magneto frame through a grounding brush which bears on the inside of the timing lever body. In this type of magneto the interrupter platinum points may be adjusted without removing the timer body as shown in Fig. 223. In the type G4, II Edition, the usual form of rocking type

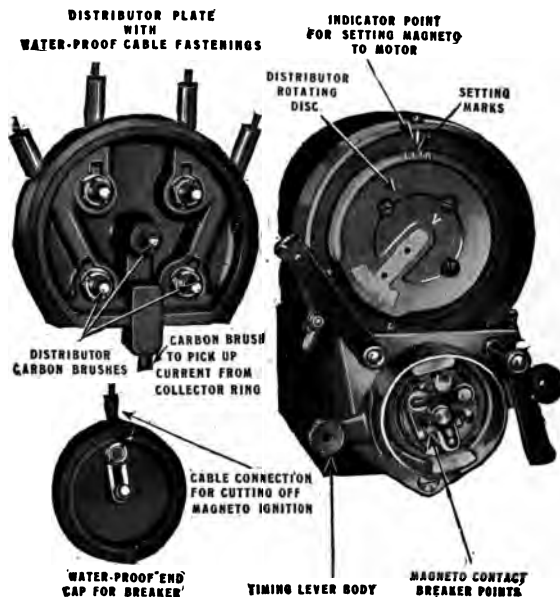

FIG. 224.—Principal parts of Eisemann high-tension magneto, type G4, II Edition.

interrupter is used, in which the interrupter lever is actuated by two steel segments or cams mounted on the inside of the timing lever body as shown in Fig. 224. The platinum contacts in both types of magnetos should be adjusted to open .010 in. to .014 in.

The armature housing or frame of the type G4, II Edition, consists of the unit-cast construction shown in Fig. 225, whereas the I Edition housing is built up of several parts screwed together. This unit-casting is extremely rigid, thus eliminating all danger of loosened screws or end plates, due to vibration or accidental twisting. Another advantage of the unit-casting is the absence of any joints. Consequently, an absolutely water-,oil-, and dust-tight protection is provided for the vital elements, such as the winding and the condenser. The unit-casting may

be bored out and machined all in one piece, and because of its rigidity, a smaller running clearance between the armature and the poles of the magnets can be maintained. This tends to give increased magnetic efficiency and, as a result, a much hotter spark.

*The Armature.*—The armature used in the Eisemann magneto is shown in Fig. 226. The armature core carries the winding and is of



FIG. 225.—Frame casting for Eisemann magneto, type G4, II Edition.

the H-shaped type, similar to that shown in Fig. 205. On this core are wound a few layers of medium sized copper wire, the beginning end of which is grounded to the armature core. The other end of the wire is connected through the interrupter fastening screw to the insulated contact of the breaker mechanism. Over this primary winding is the second-

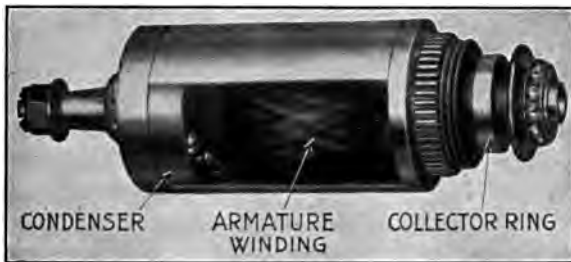

FIG. 226.—Armature for Eisemann magneto.

ary winding consisting of many turns of very fine copper wire, the wire itself being insulated its entire length and the layers carefully insulated from each other. A circuit diagram of the Eisemann, type G4, I Edition, is shown in Fig. 227. It will be noticed that the beginning of the secondary is connected directly to the end of the primary winding, and the end is

led to the collector ring which is mounted on the same end of the armature as the interrupter. The condenser, which is connected so as to protect the interrupter points, is mounted in the other end of the armature.

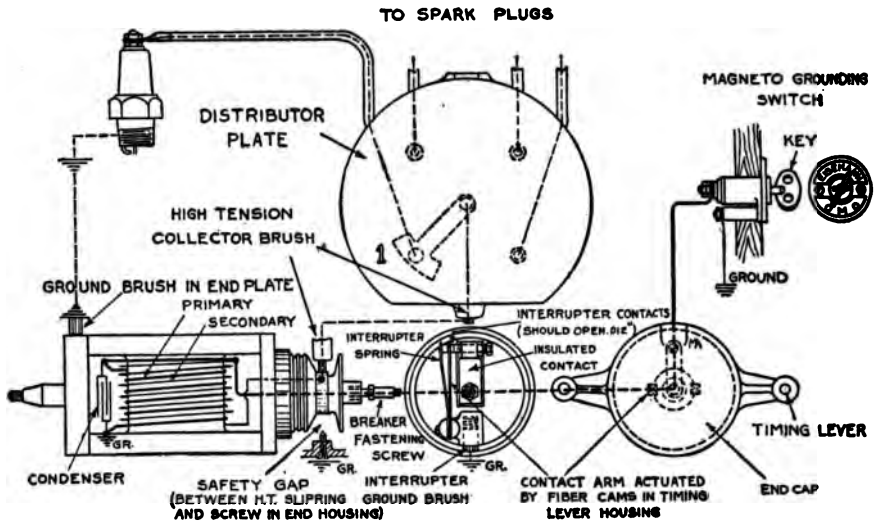

FIG. 227.—Circuit diagram of Eisemann high-tension magneto, type G4, I Edition.

**Pole Pieces.**—One of the distinct features of the Eisemann magneto is the shape of the pole pieces, which are wedge-shaped as shown in Fig. 228. These wedge-shaped pole pieces cause the magnetic lines of force to flow from the extremities of the pole pieces toward the center of the

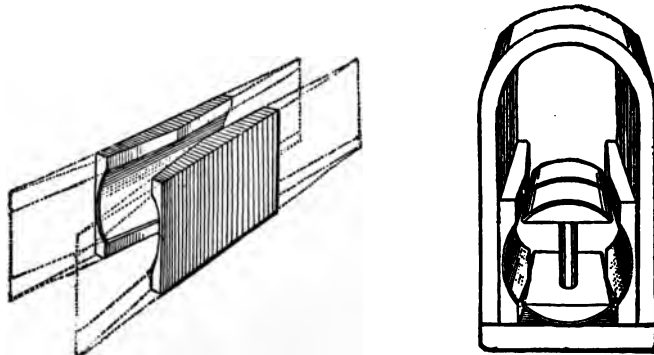

FIG. 228.—Wedge-shaped pole pieces used on older model Eisemann magnetos.

core. All of the magnetic lines of force are thus forced through the winding of the armature and are not diffused as in the case of the straight pole pieces which are most commonly used. The wedge-shaped pole pieces also prolong the duration of maximum current in the primary

winding, when the corner of the armature passes the pole pieces, thus increasing the angle of spark range and permitting a hotter spark with breaker in retard position. The armature, which is always overlapped by the pole pieces, acts as a keeper to the magnets, thereby aiding in preventing demagnetization which is common to magnetos with straight pole pieces. These pole pieces greatly reduce the wear on the coupling or gear which drives the magneto, by preventing the sudden breaking of the magnetic field and assisting in making the magneto gears noiseless.

*The Distributor.*—By placing the collector ring on the same end of the magneto as the distributor head, the necessity of carrying the high-tension current around the magneto by means of brushes and conductors is done away with. A brush in the distributor plate carried straight down to a contact with the collector ring is used and in this manner the high-tension current is carried directly to the center brush in the distributor plate. This center brush in turn makes contact with the metal insert of the distributor disc. This disc is attached to the distributor gear and, consequently, rotates with it, so that the metal insert makes contact in rotation with each of the outside carbons of the distributor plate, whence current is led to the spark plugs by the high-tension cables.

The *safety spark gap* is located in the breaker end of the magneto instead of in the arch of the magnets, as in the usual armature wound type magneto. It consists of a gap of about  $\frac{5}{16}$  in. between the collector ring and the point of a screw placed in the armature housing, immediately behind the breaker. Its purpose is to provide a by-pass for the high-tension current, thereby protecting the high-tension winding against possible injury in case a spark plug cable should become disconnected or broken.

**115. The Eisemann High-tension Dual Magneto, Type GR4.**—The Eisemann high-tension dual magneto, known as type GR4, II Edition, is shown in Fig. 229 and Fig. 230. It is used in conjunction with a battery (either dry cells or storage battery) and either the DC or the DCR type coil shown in Fig. 231.

The primary purpose of this system is to give two sources of ignition (magneto and battery), using one distributor and one set of spark plugs. The arrangement consists essentially of a direct high-tension magneto, used in conjunction with a combined transformer coil and switch which can be mounted on the dash. This transformer coil is used only in con-



FIG. 229.—Eisemann high-tension dual magneto, type GR4, II Edition.

nection with the battery, whereas the switch is used in common with both the battery and the magneto.

The magneto, as may be seen from Fig. 230, is practically the same as the type G4 independent magneto with two exceptions, the timing arm is equipped with an extra separate contact breaker for the battery current, and the distributor is modified to permit of its electrical separation from the magneto armature when distributing the battery spark.

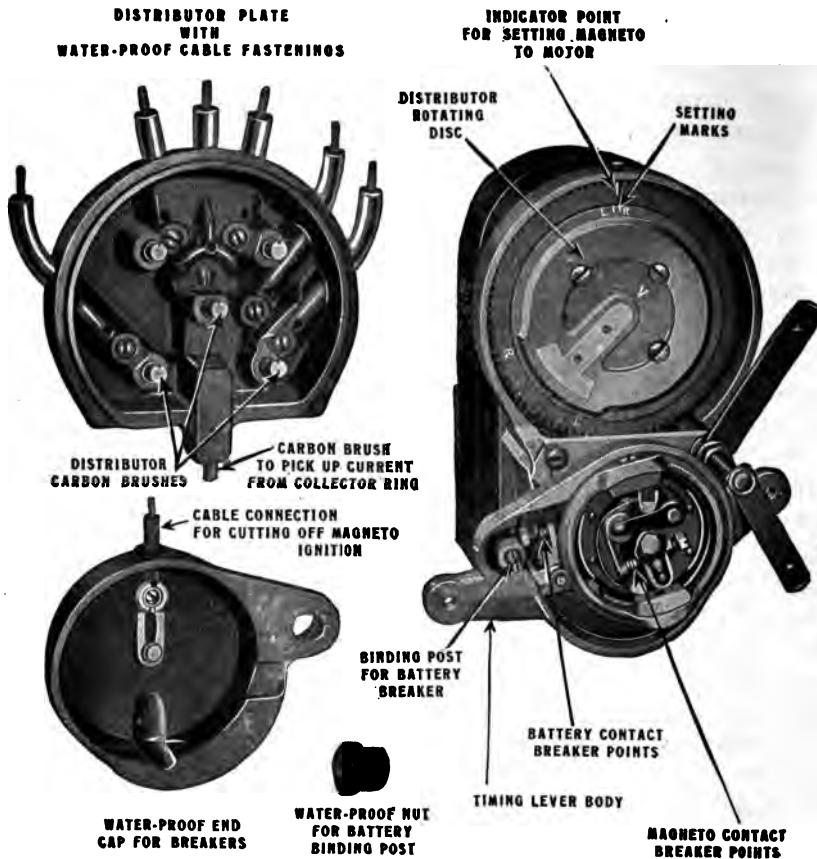
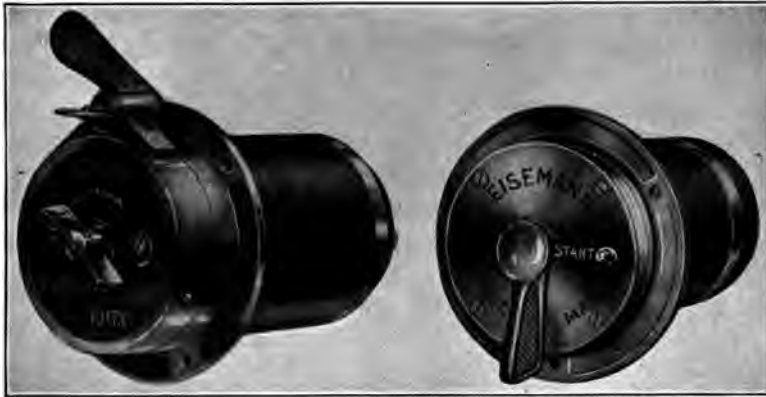

FIG. 230.—Principal parts of Eisemann high-tension dual magneto, type GR4, II Edition.

This magneto may be used with equally good results with either of the Eisemann dash coils, type DC or type DCR, Fig. 231. The coils differ only in the arrangement for starting on the spark, the DC having a push-button giving a single spark, provided the motor happens to stand with the battery breaker open; whereas the DCR has a mechanical ratchet device, delivering a shower of sparks regardless of the crank position of the engine.

A rapid back and forth motion of the starting handle on the front

f the DCR coil causes the toothed ratchet in the center to oscillate the lever *B*, Fig. 232, which, in turn, makes contact alternately at *C* and *D*. If the switch is on battery position and the battery breaker points in the magneto are closed, as they normally are, a rapid sequence of sparks will



Type DCR coil.

Type DC coil.

FIG. 231.—Dash coil and switch units for Eisemann high-tension dual magneto, Type GR4.

occur at the plugs. This shower of sparks is much more effective for starting on compression than a single spark.

A circuit diagram of the system, including the coil connections for the different switch positions, is shown in Fig. 233. As may be seen, the battery breaker operates in much the same manner as the corresponding part on the magneto. It is actuated, mechanically, by two polished steel cams attached to the magneto breaker, but it is entirely separate, electrically, from the latter. Like the magneto breaker, the battery breaker causes the spark to occur at the instant of separation of the contact points. For practical reasons, this interruption is timed to take place 10° later than the magneto, but is, naturally, subject to the same degree of advance and retard, being mounted on the same timing lever body.

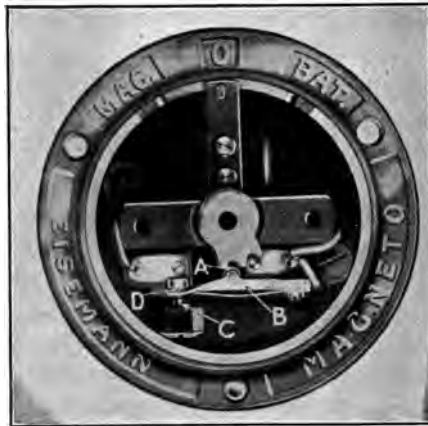
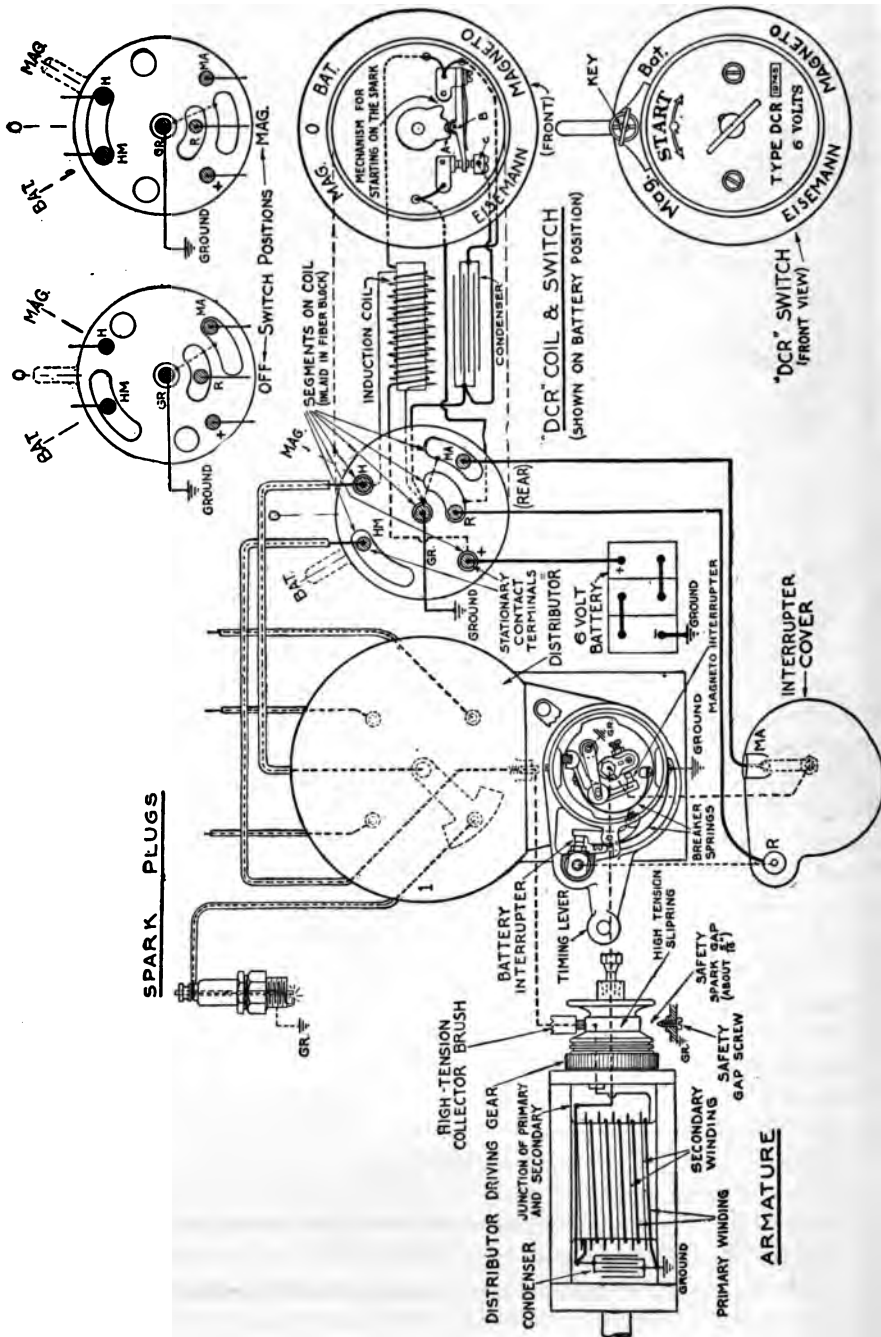

FIG. 232.—Type DCR coil with front plate removed showing mechanism for starting on the spark.

Both breakers are protected by the same waterproof cap and are easily exposed to view.

Both sets of contact points should be adjusted to open from .010 in. to .014 in. The distributor is the same as the G4 except that there is no



connection between the lower carbon brush and the center one. Cables lead from each of these brushes to the switch portion of the coil, enabling the center brush to be connected to the lower one when running on the magneto or to the coil when running on the battery.

If for any reason it is desired to operate the magneto without the coil and switch unit, it may be operated as an independent high-tension magneto, the same as the type G4, by connecting the cables marked H and HM on the distributor head, making a direct path for the high-tension current from the collector ring to the distributor.

The Eisemann type GS-4 magneto is very similar in construction to the type G4 with the exception that it is slightly smaller throughout.

**116. Timing of the Eisemann Magneto to the Engine for Variable Spark.**—Since the spark occurs when the primary circuit is broken by the opening of the platinum contacts on the breaker mechanism, it is necessary that the magneto be timed so that at full retard position of the timing lever body, the platinum contacts just begin to open when the respective piston of the engine has reached its highest point on the compression stroke. The engine should be turned by hand until piston of No. 1 cylinder is on dead center (firing point). The distributor plate should then be removed from the magneto and the driving shaft turned until the setting mark on the distributor disc is in line with the setting screw as shown in Fig. 230. (For a magneto rotating clockwise, setting mark *R* is used, and for anti-clockwise, setting mark *L* is used.) With the armature in this position and the timing lever body fully retarded, the platinum contacts of the magneto breaker are just opening, and the metal insert of the distributor disc is in connection with the carbon brush for No. 1 cylinder. The driving medium must now be fixed to the armature shaft without disturbing the position of the latter, and the cables connected to the plugs in their proper order of firing.

It has been found advisable in practice to time the battery spark slightly later than that of the magneto itself. For this reason, the battery breaker on the Eisemann dual type magneto is permanently arranged to open 10° later than the magneto breaker, although subject to the same degree of advance and retard.

**117. The Eisemann Magneto with Automatic Spark Advance.**—The Eisemann automatic spark control magneto is of the same construction as the standard high-tension instrument with the addition of the automatic mechanism, Fig. 234. The automatic control of the spark is accomplished by the action of centrifugal force on a pair of weights attached at one end to a sleeve through which runs the shaft of the magneto, and hinged at the other end to the armature. Two helicoidal splines, which engage with similarly shaped splines in the sleeve, run along the armature shaft. A coiled spring pressing against the inner edge of the sliding block normally keeps the governor closed when the engine is idle or



barely turning over. In this position the spark is fully retarded. Figure 235 shows the armature with the control mechanism mounted in place, removed from the magneto. In this illustration, the weights are shown in the position of full spark retard.

As the engine speeds up, the centrifugal force acting on the governor weights causes the latter to spread out, drawing along the shaft the sliding

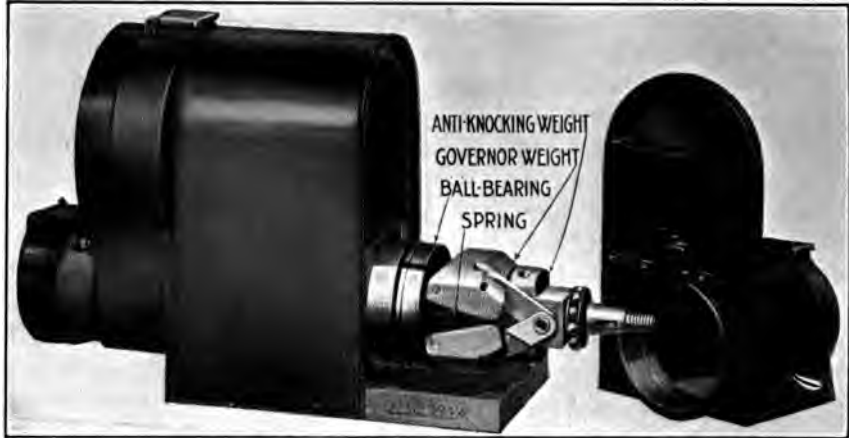

FIG. 234.—Eisemann magneto with automatic spark advance.

block, through which runs the helically cut shaft, keyed to the armature, and, consequently, causing the latter to change its relative position to the pole pieces. This causes an earlier opening of the contact breaker. The spark also occurs earlier, or is "advanced". Naturally, the higher the engine speed, the further the sliding block will travel, and the greater



FIG. 235.—Eisemann magneto armature showing automatic spark advance mechanism.

will be the amount of advance. As soon as the speed of the engine decreases, the action of the helical sleeve and the spring gradually closes the governor and "retards" the spark.

With this method of advance, the moment of current induction in the high-tension winding is brought about earlier by moving the entire armature, and with it the contact breaker or interrupter. The cams,

which lift the contact lever and cause the breaker in the primary circuit to open, are *fixed* in the correct position, and thus the break occurs only at the moment when the current in the winding is strongest.

To apply the automatic control to any engine the manufacturers have produced spindles of varying pitches to give 19, 25, 38, 45, and 60° of spark advance. For use in connection with these spindles, there are sixteen different springs. By using these different springs in connection with the governor mechanism, it is possible to produce 160 different advance curves. Many more curves can be produced by varying the length of the stop on the bronze nut. Many engines require a great deal of advance; others will permit of only a few degrees. It is necessary to take into consideration the size and shape of the combustion chamber, the compression, the position of the spark plugs, and the speed of the engine. It is universally acknowledged that an engine of high compression will give a quicker burning mixture and will not require or stand so early a spark as one of lower compression. The makers of this magneto have made a study of the requirements of the different engines on the market and are prepared to furnish an instrument with the spark advance mechanism properly adjusted to give the range of advance needed on the particular make of engine for which it is ordered.

**118. Eisemann Impulse Starter.**—One serious objection to magneto ignition is the complication introduced by the added battery or dual equipment which furnishes the spark when starting the engine. The ordinary magneto does not give a spark of sufficient intensity at cranking speeds to fire the gas in the cylinder. This drawback has been overcome by the makers of the Eisemann magneto by installing the Eisemann impulse starter on the magneto drive. This gives a hot spark even when the engine is cranked slowly by hand since the armature is snapped past the firing point by a strong coiled spring. Figure 236 is a diagrammatic sketch of this mechanism. It may be attached to any model of the Eisemann magneto and has no effect on the operation of the magneto at ordinary running speeds. At low engine speeds, it causes the armature of the magneto to rotate in a series of jumps instead of uniformly. These jumps cause the armature to cut the lines of force from the magnets at the same speed as when the engine is turning over rapidly, so that a hot spark is generated in either case.

The starter consists of a driving tube *A* and a driven tube or cup *B*, the two being connected by a spring. Within the driven cup is a loose ring *C*, called the trigger, this ring having a projection which extends through a slot in the periphery of the cup. At the bottom of the coupling is a notched bar so placed that as the cup revolves, the notch registers with the slot in the cup, so that the trigger lip drops down by gravity, catches in the notch, and locks the cup against rotation. This is the condition shown in view C. When the lip has engaged the notched bar

and the cup stops revolving, the driving tube continues to turn. This compresses the spring against a driving pin on the tube and a block fixed to the cup. At the proper point the cam on the trigger ring engages that on the tube and lifts the trigger out of the notch in the bar; the compressed spring then spins the armature of the magneto past the firing point and provides a hot spark. At cranking speeds the trigger is caught again and again as it passes the notch; but when the engine fires, the speed immediately increases to the point where the trigger ring is kept from entering the notch by centrifugal force. At this speed

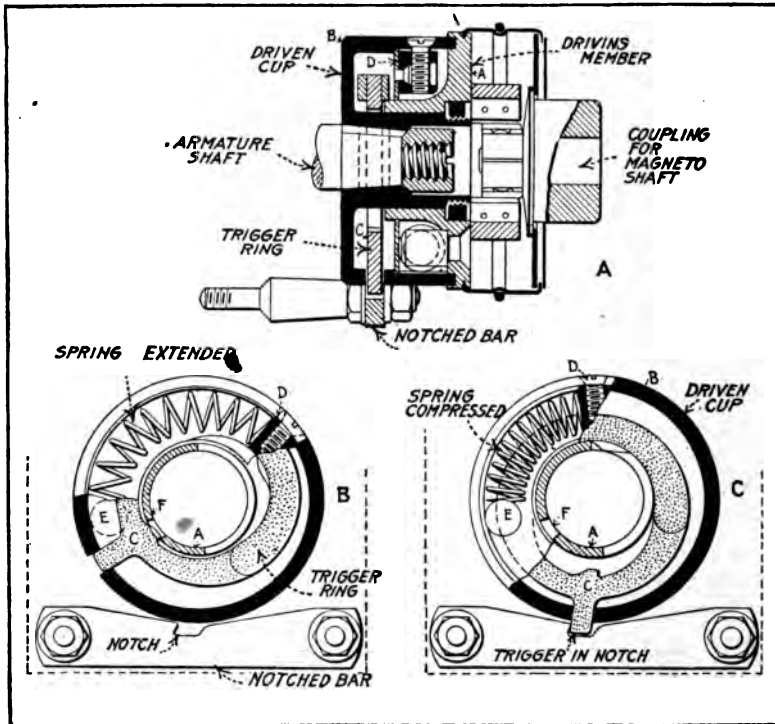

FIG. 236.—Diagrammatic sketch of Eisemann impulse starter.

the coupling acts as a solid connection between the drive and the armature. The impulse starter removes any necessity for auxiliary battery ignition for starting on heavy duty engines since a hot fat spark is generated at any speed, regardless of how slowly the crank is turned. This is especially desirable on heavy truck and tractor engines.

**119. Simms High-tension Dual Ignition System.**—The Simms dual ignition system is a combination of the high-tension type of magneto, Fig. 237, in which the high-tension current is developed in a high-tension winding mounted directly on the armature, and an added battery auxil-

by circuit for starting purposes. The battery current is broken by the dual magneto interrupter, the battery circuit being introduced to the high-tension armature winding at this point as shown in the wiring diagram.

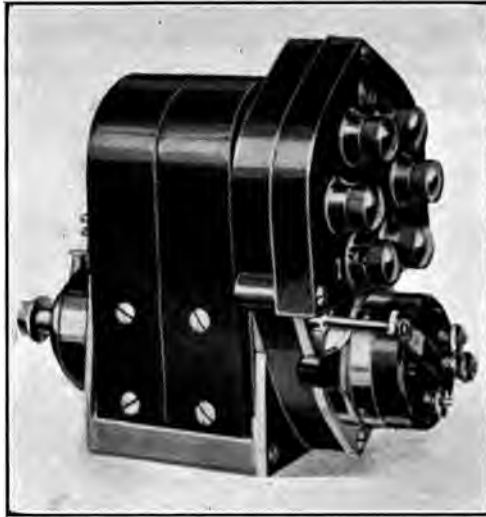

FIG. 237.—Simm's dual high-tension magneto, type SU6-S.

The contact breaker is so designed that its action is proved by the centrifugal force developed at high speeds. This dual

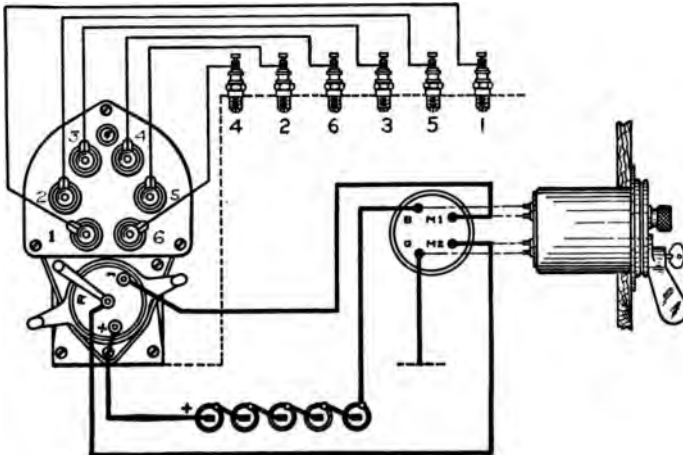

FIG. 238.—Wiring diagram, Simm's dual magneto, type SU6-S.

The magneto is known as type SU6-S. The dual coil, Fig. 239, is used with this equipment.

A special feature of the Simms magneto is the design of the pole pieces

which have extensions on the edges following the direction of rotation of the armature, Fig. 240. These extensions keep the edges of the armature shuttle within the influence of the pole in all positions from full retarded spark to full advanced spark. The result is that at the moment of breaking the circuit, the edge of the shuttle is never widely separated from the edge of the pole piece, thus giving a spark of full intensity for all positions of the armature within the limits of spark advance.

**120. The Berling High-tension Dual Magneto.**—Berling magnetos are of the true high-tension rotating armature type. The independent type magneto is complete in one unit and, without the use of a separate coil, produces a hot flame spark capable of rapidly raising the temperature of the explosive mixture in the cylinder to the flash point. The cams which operate the interrupter are integral parts of the interrupter housing. The interrupter can be inspected while the magneto is running to ascer-



FIG. 239.—Simm's dual coil and switch.

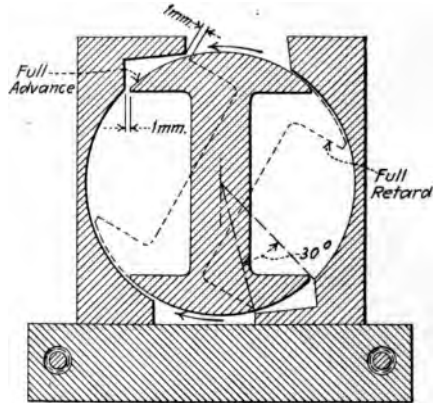

FIG. 240.—Pole pieces, Simm's magneto.

tain if it is working properly. Figure 241 is an X-ray view of the independent Berling magneto.

The Berling dual system is a true dual system consisting of two independent sources of ignition, having common control and distribution. The dual feature is made possible by adding to the independent type of Berling magneto a battery timer and a different form of yoke or brush holder. The only part of the electric circuit of the magneto that is used in common with the battery system is the distributor. The dual system may use either the vibrating or the non-vibrating type of coil. The running operation of both types is the same, the difference being in the characteristics of the starting spark. The vibrating coil provides a more certain starting ignition since the succession of sparks serves to raise the temperature of the mixture in the cylinder to the firing point.

Figure 242 shows the Berling dual magneto. This magneto is similar to the independent type with the exception of a dual yoke or brush

ler with two terminals which permit the high-tension current from coil and battery to be connected to the magneto distributor, and a battery timer which is incorporated in the cam housing which encloses

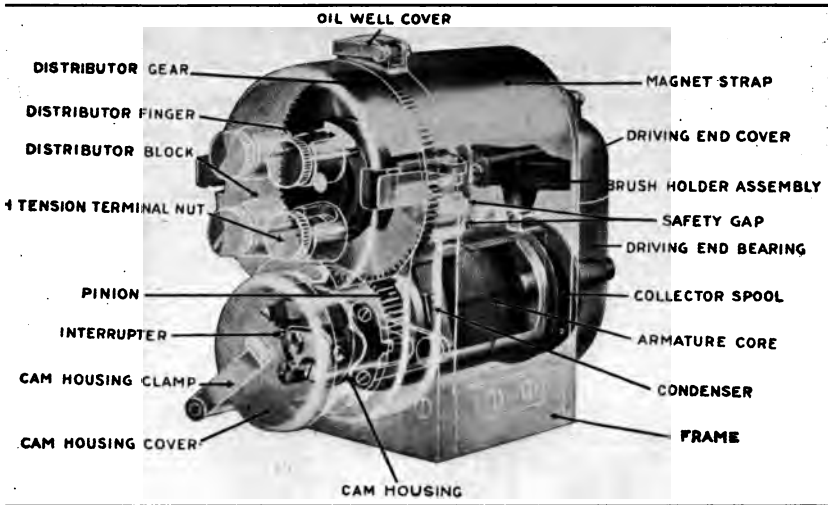

FIG. 241.—X-ray view of Berling high-tension independent magneto.

magneto interrupter. The common timing lever thus controls both the magneto and the battery spark. Means are provided for adjusting the timing of the two sparks, to provide the best relation for proper timing. The two systems are electrically independent since the only part used in common is the magneto distributor. The failure of either unit does not affect the other, unless a complete mechanical breakdown occurs. The Berling dual system may be arranged to suit any desired form of installation. The coil and switch are supplied as a single unit, or separately. An external wiring diagram of the Berling dual high-tension magneto is shown in Fig. 243. This figure shows two high-tension connections at drive end of the magneto. One of these connections carries the high-tension current generated in the dual coil; the other carries the magneto secondary current. The switch disconnects the magneto secondary circuit from the distributor, when the battery ignition is being used, thus



FIG. 242.—Berling high-tension dual magneto, type ED-61.

preventing the battery high-tension current from reaching ground through the secondary winding on the magneto.

**121. The Kingston Model O High-tension Magneto.**—The Kingston model O high-tension magneto, Fig. 244, has but one winding on the

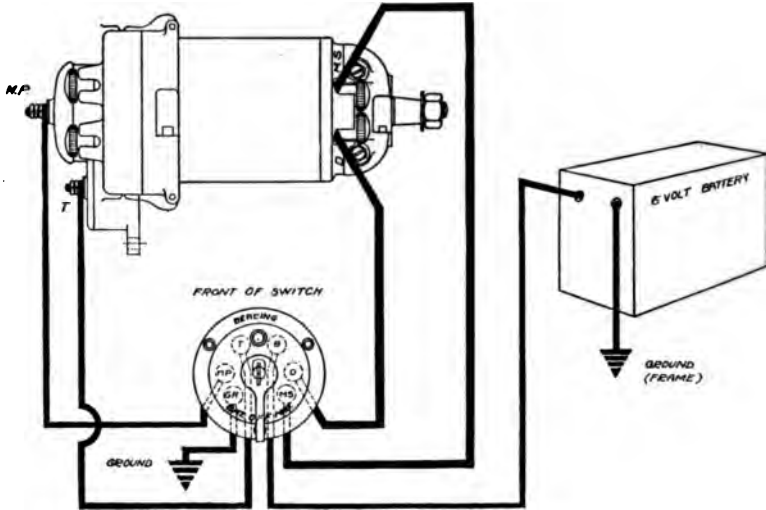

FIG. 243.—External wiring diagram of Berling high-tension dual magneto, type SU-61.

rotating armature. The primary current is generated in the armature and broken at the contact points in the interrupter. The high-tension current is produced in the secondary winding of the induction coil that is

placed under the arch of the magnets in the upper part of the instrument. Figure 245 is a sectional view of this instrument showing all the parts. The armature and the primary current generating coil carried on it are shown in the lower part of the figure. At the left end of the armature shaft is the interrupter and immediately above it the distributor. The condenser is directly above the armature, and under the arch of the magnets is the induction coil with its primary and secondary windings. This



FIG. 244.—Kingston high-tension magneto, model O, showing impulse starter at right.

magneto is complete in itself, the only external wiring necessary being the leads to the spark plugs and another lead to the switch for grounding the current generated in the armature winding. This switch is used for stopping the engine.

The Kingston magneto was developed for heavy duty engines such as those used in trucks and tractors. The large size of these engines prevents their being cranked at anything but the slowest speeds. In order

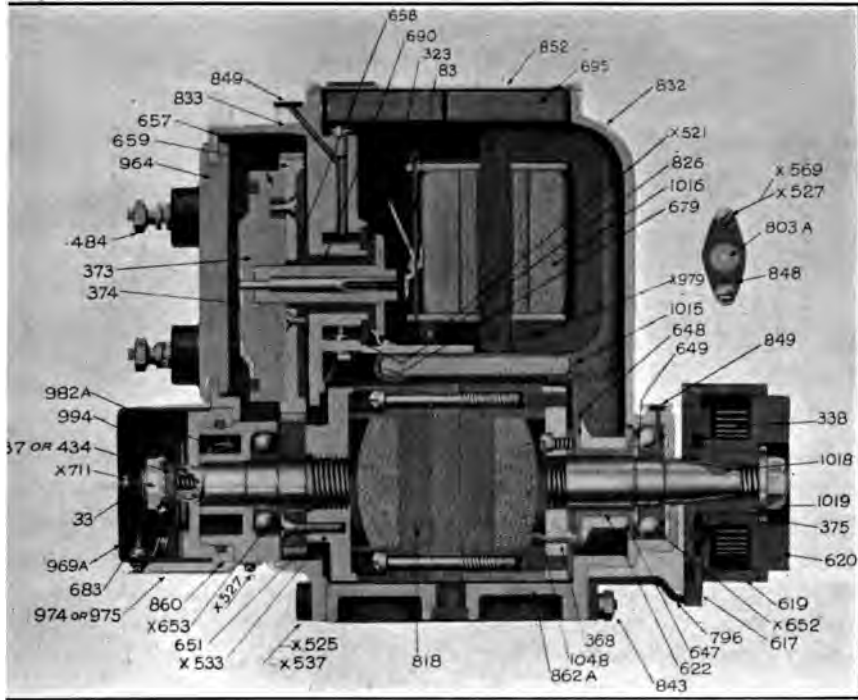

FIG. 245.—Sectional view of Kingston model O high-tension magneto.

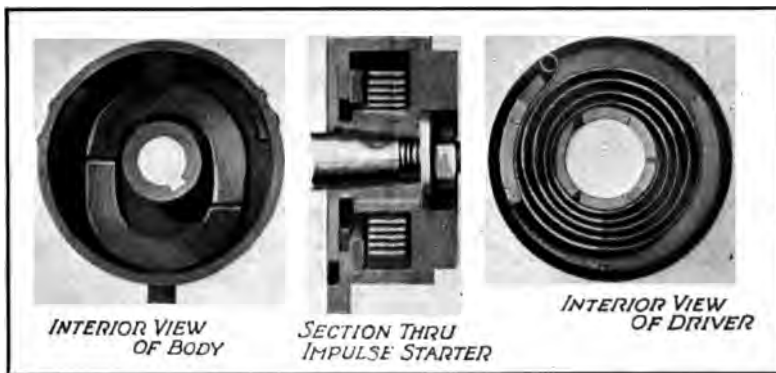

FIG. 246.—Kingston impulse starter.

To insure a good spark at the low cranking speeds, the impulse starting mechanism, shown at the right end of the armature shaft in Fig. 244 and disassembled in Fig. 246, is installed in the magneto drive. The



impulse starter consists of a driving and a driven member with a coiled spring between them. At low speeds, a third ring-shaped member drops at each revolution and a projection on the ring engages a projection on the body of the magneto, thus preventing the further rotation of the armature shaft. The driving member continues to rotate and winds up the coiled spring. At a certain point, the projection on the ring member

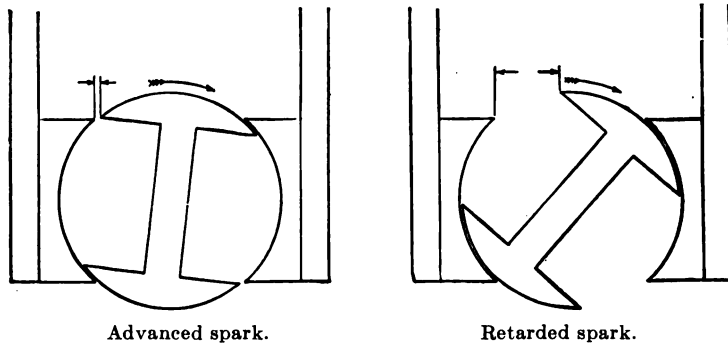

FIG. 247.—Horseshoe-type magnetos—relative positions of armature and magnets at the moment of sparking.

slips off of the stop on the magneto body. This releases the coiled spring and it immediately unwinds, driving the armature forward with a quick jerk past the firing point and giving a hot spark for starting. At ordinary engine speeds, the ring member is kept from dropping and engaging the stop by centrifugal force. Under this condition, the magneto is driven constantly at engine speed.

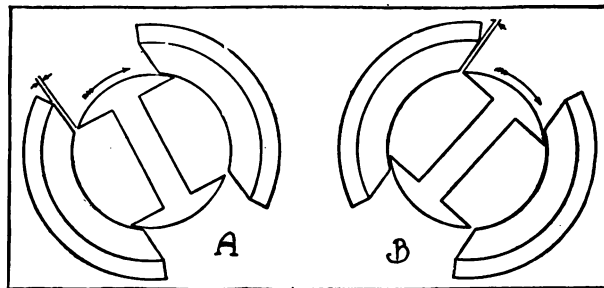

FIG. 248.—Mea magneto—relative position of armature and magneto at the moment of sparking.

**122. The Mea Magneto.**—The Mea magneto, which departs in several particulars from the usual magneto construction, is designed to give a wide range of ignition without affecting the value of the sparking current. In the ordinary horseshoe type of magneto with fixed magnets, any change in the time of the spark means that the spark

is produced at a different position of the armature with respect to the magnets as shown in Fig. 247. This naturally limits the spark range to that part of the current wave in which suitable ignition can be obtained. The Mea magneto shifts the magnets with the interrupter,



FIG. 249.—Bell-shaped magnet of Mea magneto.

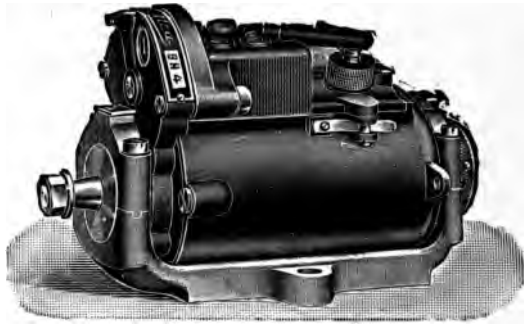

FIG. 250.—The Mea magneto.

as shown in Fig. 248, so that the armature is always in the same relation to the magnets, regardless of the advance or retard of the spark timing lever. With the standard types of Mea magnetos the sparking range is from 45° to 70°. If necessary this range can be increased.

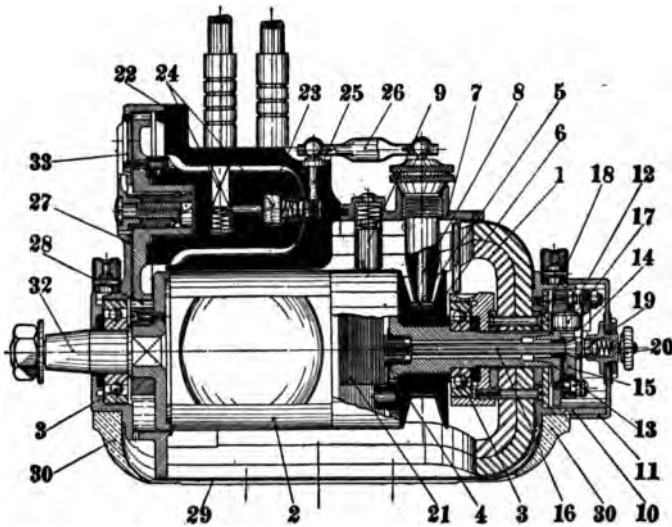

FIG. 251.—Section of Mea type BH4 magneto.

Although the Mea magneto is also offered with dual equipment for battery starting, the makers claim that the battery starting is not needed because of the fact that the magneto always takes full advantage of the armature current.

The magnets are bell-shaped, as shown in Fig. 249, and are so placed that their axes coincide with that of the armature. The exterior is seen in Fig. 250, the magnets, distributor, and interrupter housing being cradled in the frame of the base of the magneto. The timing lever is shown at the right, attached directly to the magnets. Figure 251 shows the internal arrangement. The armature is of quite conventional design with the driving connection at 32, the condenser at 21, the high-tension collector at 4, and the interrupter at the extreme right. The interrupter is built on a disc, 13, which carries the platinum contacts at 12, the movable contact being adjustable and supported by a spring, 14. This spring is in turn fastened to the insulated plate, 15, which receives the armature current through the screw, 16. The interrupter is actuated by the fiber roller, 17, which is also carried by the disc, 13. This roller is actuated by a cam disc, 18, which is provided with two projections and is attached to the field structure. In this way the spark is secured at certain definite relative positions of the armature and magnets.

## CHAPTER VIII

### MODERN HIGH-TENSION MAGNETOS—INDUCTOR TYPES

**123. Principles of the Inductor Type Magneto.**—Two low-tension magnetos of the inductor type, the Remy type RL and the Ford, have been considered in Chapter VI. In these two magnetos the current is generated in coils which do not revolve but are stationary. In the Ford magneto, the coils are mounted on a supporting plate while the magnets are mounted on the flywheel and revolve past the stationary coils. As the magnets pass these coils, the magnetic lines of force from the magnets cut the windings of these coils and generate a current in them. In this instance, the coils are stationary and the magnets revolve, in contrast to the usual magneto that has been described up to this time. In the Remy type RL low-tension magneto, both the coil and the magnets are stationary, the magnetic lines of force being made to cut the windings of the coil by the movement of a rotating element consisting of two heavy wings of iron, and known as the rotor or inductor. The movement of these two heavy wings of iron between the coil and the magnets reverses the direction of the lines of force through the coil. At the moment of reversal a strong current is induced in the coil; consequently, this type of magneto is known as an inductor magneto and all magnetos of this class, that is, with stationary windings, are said to be of the inductor type.

The essential difference between the inductor type magneto and the rotating armature type magneto is that in the rotating armature type the magnetic lines of forces are nearly stationary and the armature rotates, causing the windings on the armature to cut the stationary (or nearly stationary) lines of force. In the inductor type magneto, on the other hand, the coil or winding is stationary, while the magnetic lines of force are made to change their position with respect to the coil by the rotating inductor, thus causing the moving lines of force to cut the stationary winding or coil. The stationary winding on the inductor type magneto has certain advantages, among which may be mentioned the absence of numerous sliding electrical contacts.

Figure 252 illustrates the methods employed in generating current in the two types of magnetos. The revolving armature type magneto is represented by the drawing on the left. The magnet is stationary, the coil or wire being moved up and down between the poles. This

motion causes the wire to cut the lines of force of the magnet and sets up currents that flow back and forth in the wire as the wire is moved up and down. These currents are shown by the vibration of the hand on the current indicator. The right-hand drawing shows the action

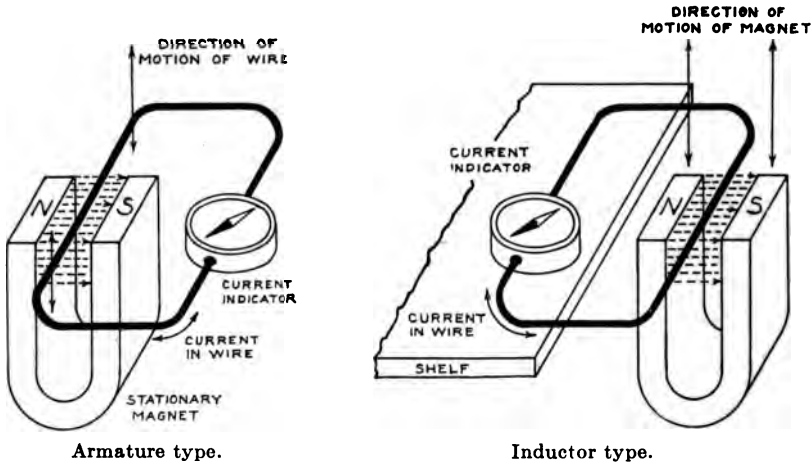

Fig. 252.—Comparison of the methods of generating current in revolving armature and in inductor types of magnetos.

in an inductor type magneto. The wire loop is placed on the edge of the shelf and the poles of the magnet are moved up and down past the wire. This motion of the magnet causes the lines of force to cut

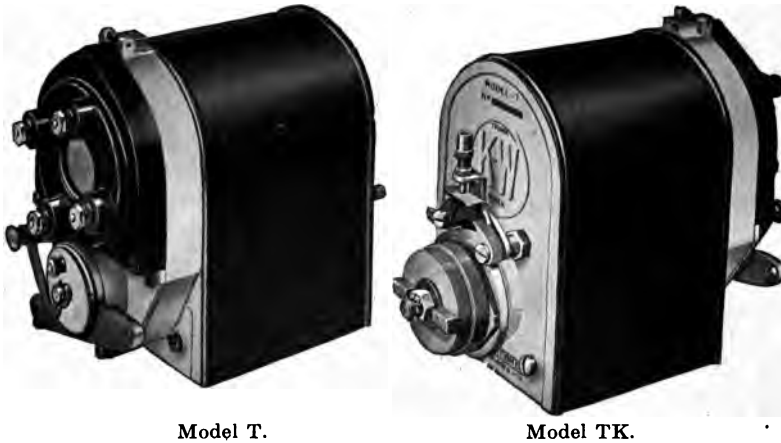
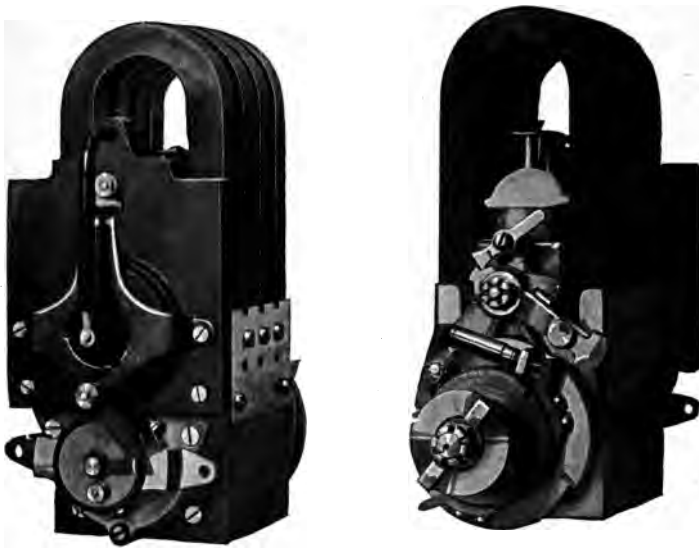

Fig. 253.—K-W inductor type magnetos for high speed automobile engines.

the wire loop and sets up currents that flow back and forth in the loop as in the previous case.

**124. The K-W High-tension Magneto.**—The K-W high-tension *magneto* is made in two models, the model T illustrated in Fig. 253,

suitable for high-speed engines with small cylinders, and the Model H illustrated in Fig. 254 suitable for large slow-speed heavy duty engines. Both models may be fitted with the K-W impulse starter for easy starting of engines that are so large that hand cranking is im-



Model H.

Model HK.

FIG. 254.—K-W inductor type magnetos for low speed, heavy duty engines.

possible at any but the slowest speeds. The K-W magneto, being of the true high-tension type, is complete in itself, requiring no external coils or other apparatus.



FIG. 255.—Interior view of K-W magneto showing rotor and coil.

Figure 255 shows the simple internal construction of the K-W magneto. Instead of having wires wound longitudinally around a revolving armature, it has a stationary flat winding of the "pancake" type as is shown in the center of Fig. 256. The rotor changes the direction of

magnetic flux through the winding four times per revolution. It revolves on two sets of annular ball bearings and does not rub against or touch any part of the magneto. The breaker or interrupter is mounted on one end of the rotor shaft.

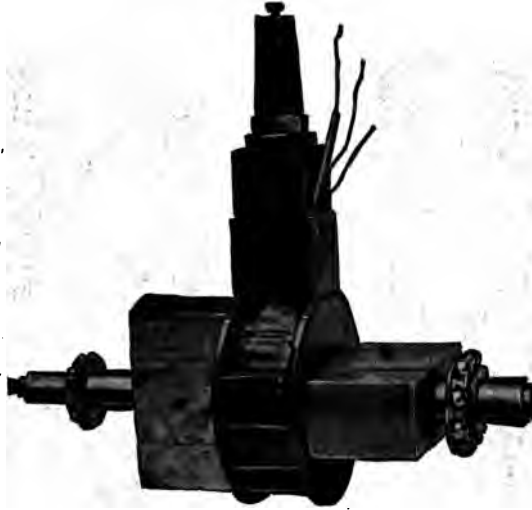

Fig. 256.—K-W rotor and coil.

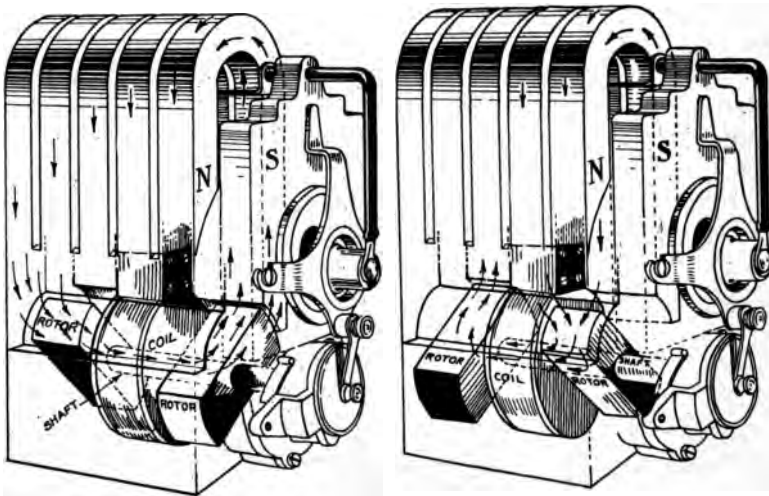

Fig. 257.—Magnetic circuit in the K-W magneto.

The principle on which the K-W high-tension magneto operates is shown in Fig. 257. This is a perspective view of the stationary coil, the pole pieces, and the rotor. The rotor is made up of two rectangular blocks of soft iron. These blocks are not made of one solid piece, but are built up of thin sheet iron stampings. This laminated construc-

tion has been found best for all parts of electrical apparatus that are subjected to the rapid reversal of magnetic lines of force since it reduces certain losses present in the solid construction. The two rotor blocks are placed at right angles to each other some distance apart on the rotor shaft. The space between the blocks is occupied by the coil which is supported in this position and remains stationary, while the rotor shaft turns within it and the rotor blocks rotate on either side. The pole pieces do not extend completely around the moving parts, as in the rotating armature type of magneto, but extend only over the upper portion of this space. The drawing to the left in the figure shows one end of the rotor block on the *far* side of the coil in contact with the N pole piece and one end of the *near* rotor block in contact with the S pole piece. In this position of the rotor the magnetic path from one pole to the other is as follows: The magnetic lines leave the N pole and pass through the far rotor block until they come to the rotor shaft, then pass through the rotor shaft and through the center of the coil to the other rotor block from which they enter the S pole of the magnets. The drawing to the right in the figure shows conditions one-quarter of a revolution of the rotor later. The *near* rotor block is now in contact with the N pole while the *far* block is in contact with the S pole. The path of the magnetic lines of force is now from the N pole into the near rotor block, through the rotor shaft and the center of the coil to the far rotor block and into the S pole. The arrows in the two drawings show the magnetic path in each case. It will be noticed that the direction of the magnetic flux through the center of the coil is opposite in direction in the second case to what it was in the first case. The reversal takes place every time the rotor is turned one-quarter of a revolution. This reversal of the magnetic flux through the coil every quarter revolution gives four current pulses every revolution. The rotating armature type magneto gives only two pulses of current per revolution. The K-W magneto, therefore, is capable of furnishing ignition for any engine at but one-half the customary magneto speed. The ability to furnish four sparks per revolution is of great advantage in eight- and twelve-cylinder engines. The magneto shaft in an eight-cylinder engine, using a magneto of this type, rotates at crankshaft speed, while that for a twelve-cylinder rotates at one and one-half times crankshaft speed. Other types of magnetos producing two sparks per revolution of the armature require a magneto speed of twice crankshaft speed for the eight-cylinder engine and three times crankshaft speed for the twelve-cylinder engine.

Figure 258 shows the current wave generated by the shuttle type magneto, and Fig. 259 shows the current wave produced by the K-W magneto. The K-W construction gives twice the number of current impulses per revolution.

A cross section of the K-W model T high-tension magneto is shown



in Fig. 260. This shows the winding between the two rotor blocks in the lower part of the magneto. This winding consists of two parts, the primary and the secondary. The breaking of the primary circuit builds

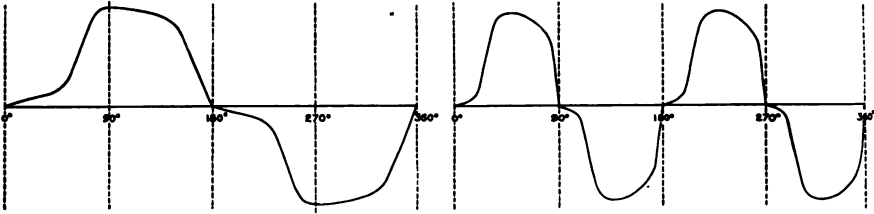
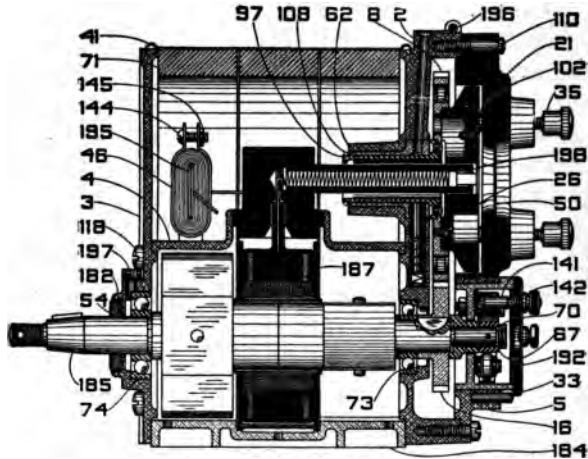

FIG. 258.—Current waves of the rotating armature type magneto.

FIG. 259.—Current waves of the K-W inductor type magneto.

up in the secondary circuit the high-tension surge of current which is distributed to the proper spark plug by the distributor at the upper



- |                                |   |
|--------------------------------|---|
| 2. Gear housing.               | 74. Rotor shaft bearing.                |
| 3. End piece.                  | 97. Distributor gear shaft.             |
| 4. Magneto case.               | 102. Distributor brush.                 |
| 5. Triangular end piece.       | 108. Distributor shaft retainer spring. |
| 8. Distributor gear.           | 110. Distributor block screw.           |
| 16. Pinion.                    | 118. End piece screw.                   |
| 21. Distributor block.         | 141. Primary circuit plunger.           |
| 26. Distributor gear moulding. | 142. Primary plunger thumb nut.         |
| 33. Circuit breaker cap.       | 144. Condenser case screw.              |
| 35. Terminal thumb nut.        | 145. Condenser case screw nut.          |
| 41. Magneto cover.             | 182. Dust washer.                       |
| 46. Condenser case.            | 184. Magneto base.                      |
| 50. Distributor block window.  | 185. Rotor shaft.                       |
| 54. Dust washer cap.           | 187. Windings.                          |
| 62. Distributor shaft washer.  | 192. Cover plate.                       |
| 67. Cam.                       | 195. Condenser.                         |
| 70. Cam retainer nut.          | 196. Gear housing oil cover.            |
| 71. Magnet.                    | 197. End piece oil cover.               |
| 73. Rotor shaft bearing.       | 198. High-tension lead.                 |

FIG. 260.—Cross section of K-W high-tension magneto, model T.

right part of the figure. The condenser is located under the arch of the magnets as shown at 195.

The impulse starter used on the K-W magneto is similar to the ones

already described. However, instead of being automatic in its operation, thus coming into action every time the speed of the engine drops below a certain point, it is normally rendered inactive by a latch or catch. This catch must be tripped before cranking the engine, thus allowing the impulse starter to come into play and snap the rotor rapidly past the firing point, giving a hot spark for starting. As soon as the engine fires and comes up to speed, the catch automatically hooks up and again renders the impulse starter inactive. K-W magnetos fitted with the impulse starter are designated by the letter K following the regular model letter. For instance, a model T magneto fitted with an impulse starter is known as a model TK. The impulse starter is shown in place on the model TK in Fig. 253 and on the model HK in Fig. 254.

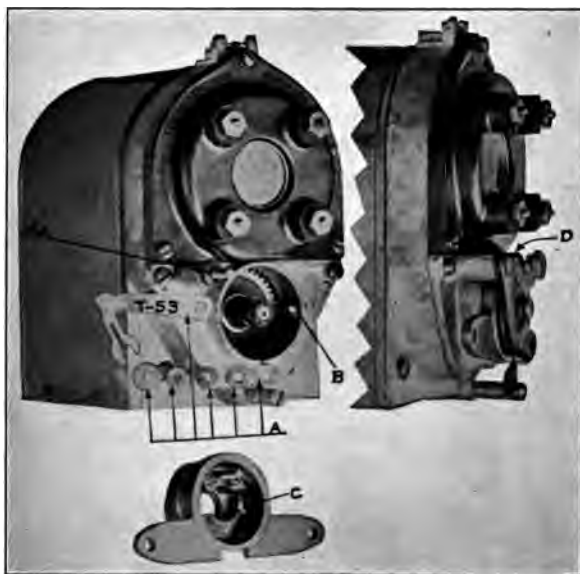

FIG. 261.—K-W model T magneto with breaker housing removed.

The K-W model T high-tension magneto is shown in Fig. 261 with the breaker housing removed for the purpose of showing the construction of the interrupter. The breaker points, *C*, are carried on the breaker housing and may be examined and adjusted with the magneto running. The breaker housing fits into the cup or recess *B* and is held in place by the retaining spring marked T-53 which fits over the stud *AA* and is held on by the insulating washers, hexagonal nuts, and thumb nut shown at *A*. These washers, nuts, etc. are shown correctly assembled on the stud at *D*. In assembling the breaker housing parts, care should be taken that these washers are put on exactly as shown. The dust should be cleaned off of the breaker housing and other parts of the magneto at frequent

intervals. Any rough edges on the contact points should be smoothed off with a fine file or oil stone.

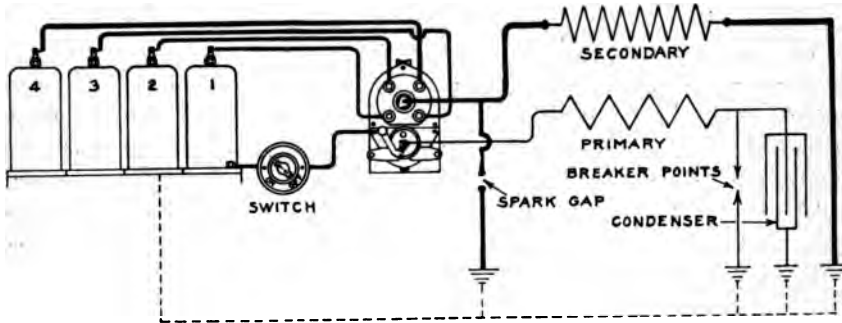

Fig. 262.—Circuit diagram, K-W model T high-tension magneto.

Figure 262 is the circuit diagram for the K-W model T high-tension magneto. The primary and secondary windings are contained in the stationary coil. The ignition switch serves to ground the primary current when the engine is to be stopped. The high-tension winding is protected by a spark gap. A condenser is connected in parallel with the breaker points for the purpose of preventing excessive sparking at the points and to absorb the arcing, or hang-over current, thus causing a rapid collapse of the primary field and producing a more vigorous spark in the secondary circuit.



Fig. 263.—K-W model W magneto for an eight-cylinder engine.

The K-W model W magneto, Fig. 263, is a high-speed instrument especially designed for airplane engines of eight or twelve cylinders. The distributor block is of liberal dimensions, permitting the distributor segments to be spaced sufficiently far apart to eliminate any possibility of arcing between segments. The circuit breaker parts are of ample size to withstand the rapid movements and

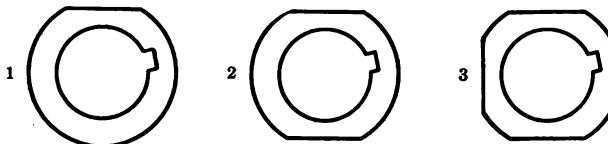

Fig. 264.—K-W magneto interrupter cams.

vibrations of the high-speed magneto. The possibility of ignition failure, due to the loosening of screws, is prevented by using rivets to hold the

important parts together. The construction throughout is very rugged. For engines which are hard to pull over compression in starting, the regular K-W impulse starter may be fitted.

The interrupter cams used with the K-W magnetos are shown in Fig. 264. These are made to give a single spark, two sparks, or four sparks per revolution of the rotor shaft. The speed of the rotor varies with the number of cylinders on the engine. A single-cylinder four-stroke engine magneto uses cam No. 1 and is driven at crankshaft speed. This gives a spark at the end of the exhaust stroke as well as at the regular firing time. The two-cylinder engine magneto uses cam No. 1 at crankshaft speed, giving one spark per revolution of the crankshaft. The three-cylinder engine uses cam No. 1 driven at  $1\frac{1}{2}$  times crankshaft speed. The four-cylinder engine uses cam No. 2 at crankshaft speed, giving two sparks per revolution of the crankshaft. The six-cylinder engine uses cam No. 2 at  $1\frac{1}{2}$  times crankshaft speed, giving three sparks per revolution of the crankshaft. The eight-cylinder engine uses cam No. 3 driven at crankshaft speed, giving four sparks per revolution of the crankshaft. The twelve-cylinder engine uses cam No. 3 driven at  $1\frac{1}{2}$  times crankshaft speed, giving six sparks per revolution of the crankshaft. The large number of current impulses per revolution of the rotor allows the K-W magneto to be driven at a relatively low speed—a decided advantage in high-speed multi-cylinder ignition.

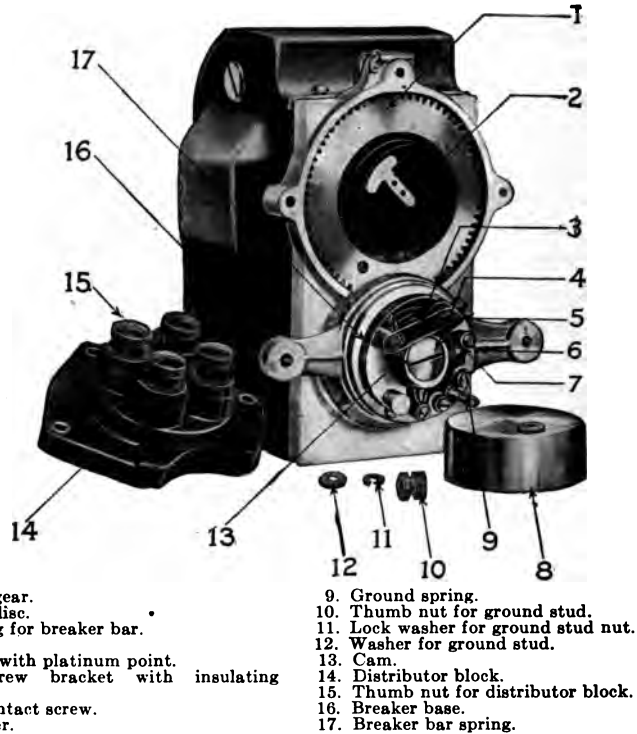

FIG. 265.—The Dixie high-tension four-cylinder magneto, model 46.

**125. The Dixie Magneto for Four- and Six-cylinder Engines.**—The Dixie high-tension magneto, the four-cylinder model of which is shown in Fig. 265, is a typical inductor type instrument operating on what is known as the "Mason Principle," with a stationary winding and a rotating inductor or rotor. The construction and general arrangement of the various parts are shown in Fig. 266, which is a front view with the distributor block and the breaker cover removed; and in Fig. 267, which is a side view, with the cover and one magnet removed. The magnets and rotating element are shown in Fig. 268.

It will be noted that the magneto consists principally of a pair of magnets, a rotor, a field structure, a winding, an interrupter, and a condenser. The rotor, Fig. 269, consists of two revolving wings, *N* and *S*, separated by a bronze center-piece, *B*. The ends of the wings are brought into contact with the poles of the magnets, as shown in Fig. 268, and, therefore, bear the same polarity of magnetism as the poles of the magnets with which they are in contact. This polarity of the wings is always the

same as there is no reversal of magnetism through them. The rotor is surrounded by a field structure which carries laminated pole extensions, on which the winding with its laminated core is mounted. As the rotor revolves, the magnetic flux penetrates the core of the winding, first in one direction and then in the other, according to the position of the rotor in relation to the poles of the field structure as shown in Figs. 270, 271, 272, and 273. Figure 271 shows the rotor in such a position that the flux enters wing *N*, passes through the core *C*, and returns to wing *S* of the rotor. Figure 273 shows the flux passing through the coil in the reverse direction.



- |  |                                      |
|--|--------------------------------------|
| 1. Distributor gear.                               | 9. Ground spring.                    |
| 2. Distributor disc.                               | 10. Thumb nut for ground stud.       |
| 3. Finger spring for breaker bar.                  | 11. Lock washer for ground stud nut. |
| 4. Cam screw.                                      | 12. Washer for ground stud.          |
| 5. Breaker bar with platinum point.                | 13. Cam.                             |
| 6. Contact screw bracket with insulating bushings. | 14. Distributor block.               |
| 7. Platinum contact screw.                         | 15. Thumb nut for distributor block. |
| 8. Breaker cover.                                  | 16. Breaker base.                    |
|  | 17. Breaker bar spring.              |

FIG. 266.—Front view of Dixie magneto with distributor head and breaker cover removed.

The greatest intensity in the primary circuit occurs when the rate of change of flux or magnetic lines of force through the core is a maximum. This occurs when the rotor is in the position shown in Fig. 272, where the rotor wings have just reversed the direction of flux through the core, the gap between the trailing wing corner and the pole piece being from .015 in. to .035 in., preferably .020 in. Consequently, the interrupter contact points should be adjusted to break the primary circuit when the rotor is in this position. A circuit diagram of the magneto is shown in Fig. 274 from which it will be seen that the primary circuit is of the interrupted

primary current type. The breaking of the primary circuit induces a high-voltage current in the secondary winding, this current being directed to the proper spark plug by a distributor driven by a gear on the rotor shaft. The condenser, one terminal of which is connected to the insulated end of the primary coil and the other terminal grounded to the magneto frame, is mounted on the top of the coil.

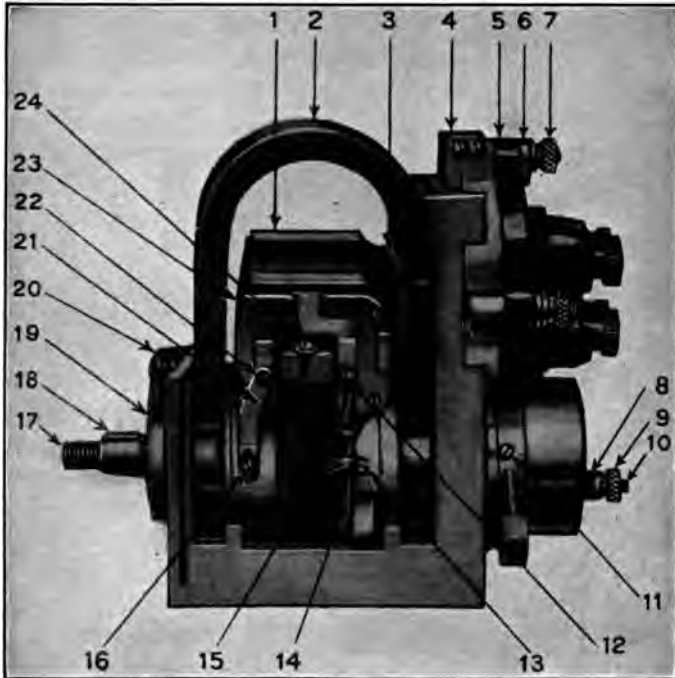

- |   |  |
|---|--|
| <ul style="list-style-type: none"> <li>1. Condenser.</li> <li>2. Magnet.</li> <li>3. Gap protector.</li> <li>4. Oil hole cover, front.</li> <li>5. Stud for distributor block.</li> <li>6. Clamp for distributor block.</li> <li>7. Thumb nut for distributor block.</li> <li>8. Hexagonal nut for grounding stud.</li> <li>9. Thumb nut for grounding stud.</li> <li>10. Grounding stud.</li> <li>11. Screw and washer for fastening breaker.</li> <li>12. Screw and washer for fastening condenser and primary lead to winding.</li> <li>13. Screw and washer for fastening primary lead tube clamp.</li> </ul> | <ul style="list-style-type: none"> <li>14. Primary lead tube.</li> <li>15. Primary lead tube clamp.</li> <li>16. Screw and washer for fastening grounded clip to pole structure.</li> <li>17. Rotor shaft.</li> <li>18. Drive key.</li> <li>19. Back plate.</li> <li>20. Oil hole cover, back.</li> <li>21. Grounding clip.</li> <li>22. Screw and washer for fastening grounding clip to winding.</li> <li>23. Winding.</li> <li>24. Screw and washer for fastening winding to pole structure.</li> </ul> |
|---|--|

Fig. 267.—Side view of Dixie magneto with cover and one magnet removed.

One of the outstanding features of the Dixie magneto is the shifting of the pole pieces with the timing lever, upon advancing and retarding the spark. This permits the breaker to interrupt the primary circuit at all times, when the primary current is flowing at its maximum, thus causing a spark of maximum intensity at all positions of the breaker.

Since the coil windings are not on a revolving armature, the interrupter

is built like that for a low-tension magneto; that is, the interrupter mechanism is mounted on the interrupter housing and the cam is revolved with the rotor shaft. This construction permits the adjusting of the contact points with the engine and magneto running. The contacts



FIG. 268.—Rotor and magnets for Dixie magneto.

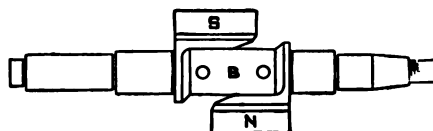
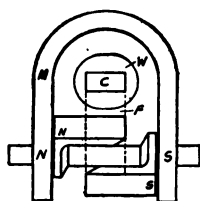
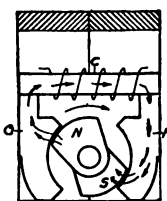

FIG. 269.—Rotating element in Dixie magneto.



270



271

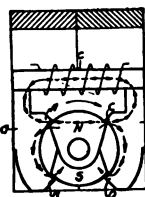

272

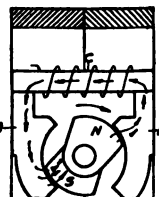

273

FIG. 270 to 273.—Showing the principle of the Dixie magneto.

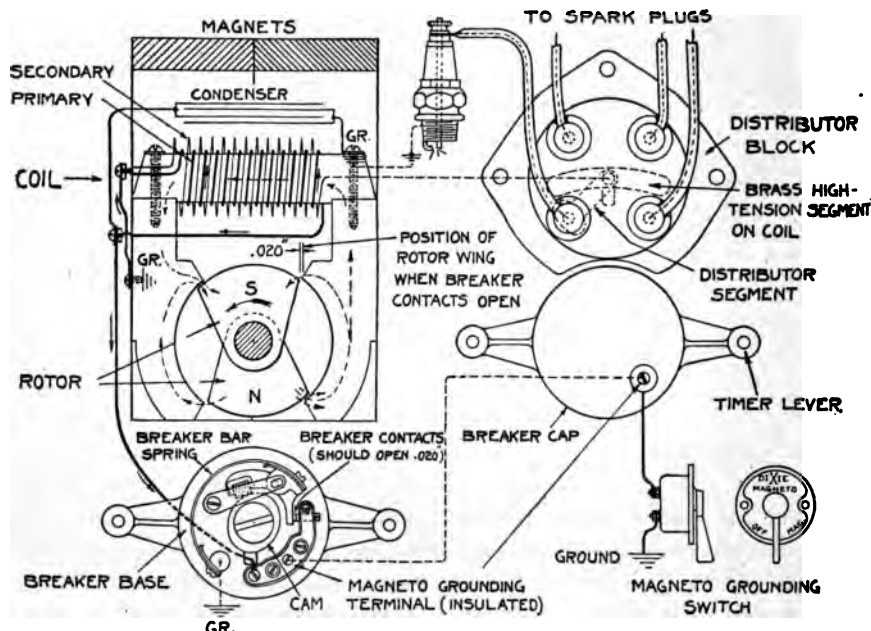

FIG. 274.—Circuit diagram of Dixie high-tension magneto, model 46.

are made of platinum and should be adjusted to open .020 in. This

adjustment can be made with a screwdriver, as shown in Fig. 275, by turning the stationary contact screw after loosening the clamp screw which holds it firmly in place. Care must be exercised to retighten the clamp screw after adjusting.

*Magneto Switch.*—Extending through the magneto breaker cover is an insulated terminal which is connected to the insulated end of the magneto primary winding. This terminal is also connected to a grounding switch by which the primary winding can be grounded or short

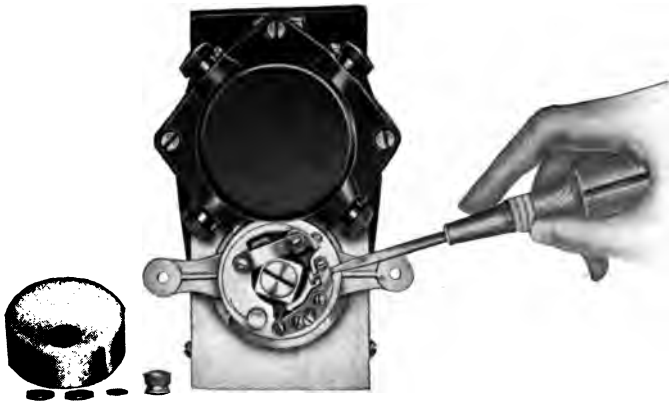

FIG. 275.—Adjusting contact joints, Dixie magneto odel 46.



FIG. 276.—Dixie magneto switch.



FIG. 277.—Aero four-cylinder magneto.

circuited, and ignition prevented. The Dixie magneto switch is shown in Fig. 276. The wire leading from the magneto is attached to one of the terminals on the back of the switch and the other terminal on the switch is grounded. The ignition is locked when the switch lever is in the "OFF" position. When in this position, the switch lever may be taken out, preventing the operation of the magneto.

**126. The Splitdorf Aero Magneto.**—The Aero high-tension magneto, Fig. 277, resembles very closely the Dixie magneto, of which it may be



said to be the outgrowth since the principle of operation of the Dixie magneto has been modified and improved upon in the Aero magneto. The principal changes made in the Aero magneto, as contrasted with the Dixie magneto, are in the rotor and in the shape of the pole pieces. The rotor of the Aero magneto for four-, six-, and eight-cylinder engines has four lobes or shoes, as shown in Fig. 278, while the Dixie rotor has but

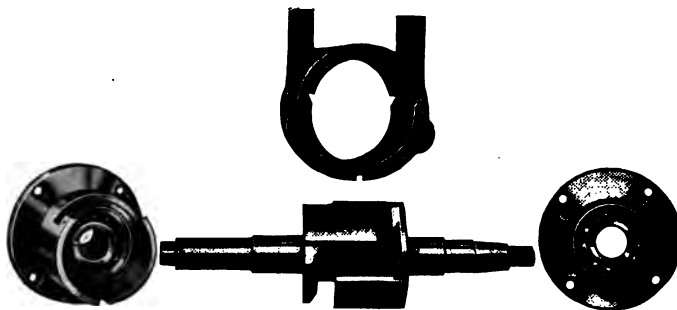
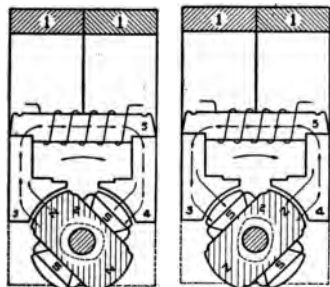

FIG. 278.—Rotating poles, bearings, and field of Aero Magneto.

two lobes, Fig. 269. The difference in the pole pieces may be noticed by comparing Fig. 279 and Fig. 280, with Figs. 270–273. The pole pieces in the Aero magneto do not extend completely around the rotor as in the Dixie magneto, but are confined to the upper quarters of the circle.

The Aero magneto generates four current impulses in the primary winding per revolution of the rotor. However, only one-half of these current impulses are used to produce a spark at the spark plug. The current wave of the Aero magneto is very similar to the wave shown in Fig. 258, where it will be seen that of the four current impulses produced per revolution of the rotor, two are drawn above the axis and two are drawn below the axis. The impulses above the axis are called positive loops and indicate that the current is flowing in a given direction through the circuit. The impulses below the axis are called negative loops and indicate that the current is flowing in the opposite direction through the circuit. The



FIGS. 279 and 280.—Reversal of magnetic flux through the coil in Aero magneto.

high-tension surges of current produced in the secondary circuit by the opening of the breaker points also reverse in direction, so that the high-tension current will jump from the center electrode of the spark plug to the shell at one spark, and from the shell to the center electrode at the next spark. In the Aero magneto, the breaker points open only on the positive loops, thus creating current surges only in one direction in the high-tension circuit.

With this construction, the high-tension current produced in the secondary winding and delivered to the spark plugs is uniform; that is, the high-tension current from the magneto to the spark plugs flows in one direction only and this direction is such that the current always jumps from the shell to the center electrode. The manufacturers claim that this constant direction of the spark insures a spark of great intensity, uniformity, and superior igniting power.

The operation of the rotor in changing the direction of the magnetic flux through the core of the coil is shown in Fig. 279 and Fig. 280. In Fig. 279 the magnetic flux goes in one direction through core 5. When wing *N* is opposite 3, flux goes through 3 and 5 to 4, back to wing *S* of opposite polarity. Until the wing *N* has passed the leaving pole piece 3, the action of the cam holds the platinum contacts of the breaker apart, thereby preventing current from being induced in the primary winding



Fig. 281.—Aero magneto with distributor block and interrupter cover removed.

on core 5, leaving the core free from magnetic interference and preparing it for a powerful magnetic and electrical action when the polarity of the field structure and core is reversed upon further rotation.

In Fig. 280, the magnetic flux goes in the reverse direction through core 5. Wing *N* has now moved over to 4 and the direction of the flux is reversed, going from 4 through 5 to 3. When wing *S* passes the leaving pole piece 3, the action of the cam separates the platinum contacts of the circuit breaker, thus breaking the primary circuit. The four wings of the rotor are alternately of north and south polarity. When the wings of north polarity pass the field poles, the platinum contacts remain separated; this prevents the production of primary current. At the same time the magnetism of the field poles and the core of the winding are brought to a state of absolute zero, after which the contact points come together. When the wings of south polarity pass the field poles, thus cutting the magnetic lines of force, the contacts are separated at

the moment of greatest magnetic intensity in the core of the winding—once in 180°—and the unidirectional high-tension current is carried to the spark plug.

The Aero magneto with distributor block and interrupter cover removed is shown in Fig. 281. The contact points and interrupter lever are mounted on the inside of the breaker housing. The cam is carried by the rotor shaft and has two lobes breaking the primary circuit every 180° of rotation of the shaft. The contact points may be adjusted while

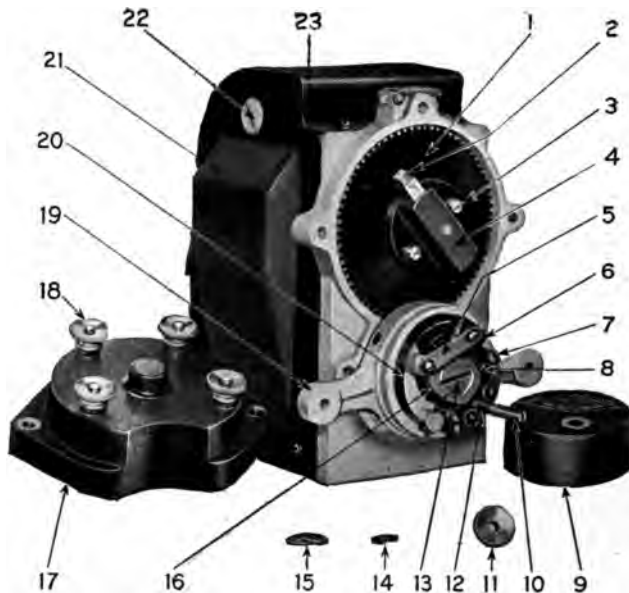

#### Front View Parts

- |                                   |                                      |
|-----------------------------------|--------------------------------------|
| 1. Distributor Gear.              | 13. Cam Screw.                       |
| 2. Distributor Brush.             | 14. Lock Washer for Ground Stud Nut. |
| 3. Distributor Finger Screw.      | 15. Washer for Ground Studs.         |
| 4. Distributor Finger.            | 16. Cam.                             |
| 5. Finger Spring for Breaker Bar. | 17. Distributor Block.               |
| 6. Breaker Bar.                   | 18. Thumb Nut for Distributor Block. |
| 7. Lock Screw for Platinum Point. | 19. Breaker Base.                    |
| 8. Platinum Contact Screw.        | 20. Breaker Bar Spring.              |
| 9. Breaker Cover.                 | 21. Side Plate.                      |
| 10. Ground Stud.                  | 22. Side Plate Stud.                 |
| 11. Thumb Nut for Ground Stud.    | 23. Magnet Cover.                    |
| 12. Contact Screw Bracket.        |                                      |

FIG. 282.—Aero magneto.

the magneto is running, similar to the manner shown in Fig. 275. The contact points should separate .020 in. or  $\frac{1}{50}$  in. when the fiber block on the interrupter arm is on the highest part of the cam. The circuit diagram of the Aero magneto is the same as that for the Dixie magneto, Fig. 274. Figure 282 and Fig. 283 show the Aero magneto with many of the parts designated. The resemblance to the Dixie magneto is quite marked.

Figure 284 is a side view of the Aero magneto showing the points requiring oiling. The frequency of oiling depends upon the nature of the

service to which the magneto is subjected. In general, it may be stated that the magneto should be oiled at *A* with four drops of light oil every 20 hours of operation; at *B* with two drops of light oil every 20 hours of operation; and at *C* one drop of light oil should be applied to the bearing of the breaker arm with a toothpick every 200 hours of operation. Figure 285 shows the breaker base and the hole for oiling the breaker arm bearing. Every possible precaution should be taken to prevent oil

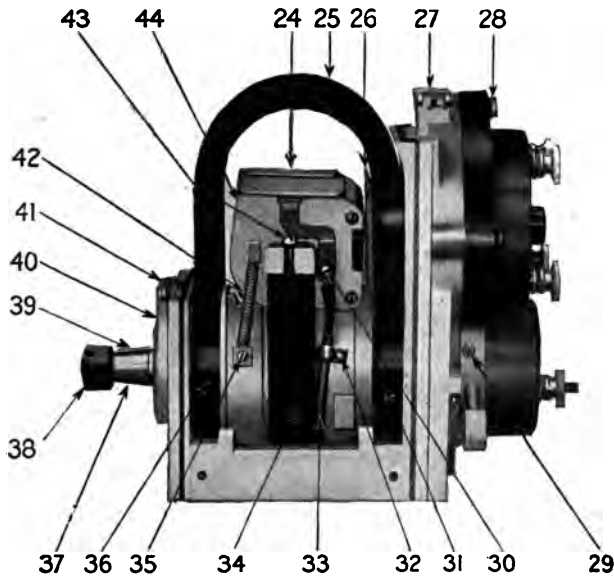

Side View Parts

- |  |   |
|--|---|
| 1. Condenser.  | 12. Primary Lead Tube Clamp.                                      |
| 2. Magnet.   | 13. Screw and Washer for Fastening Ground Clip to Pole Structure. |
| 3. Gap Protector.  | 14. Rotor Shaft.  |
| 4. Oil Hole Cover, Front.  | 15. Shaft Nut.  |
| 5. Screw for Distributor Block.  | 16. Woodruff Key.   |
| 6. Thumb Nut for Ground Stud.  | 17. Back Plate.   |
| 7. Ground Stud.  | 18. Oil Hole Cover, Back.   |
| 8. Screw and Washer for Fastening Breaker.                               | 19. Ground Clip.  |
| 9. Screw and Washer for Fastening Condenser and Primary Lead to Winding. | 20. Screw and Washer for Fastening Winding to Pole Structure.     |
| 10. Screw and Washer for Fastening Primary Lead Tube Clamp.              | 21. High-tension Winding.   |
| 11. Primary Lead Tube.   |   |

FIG. 283.—Aero magneto.

from getting on the platinum points as this would result in flashing at the contact points when running, and consequent misfiring of the engine.

The operation of the magneto is controlled by the magneto or ground switch, Fig. 286. In the "ON," or running position, the primary current is completed through the circuit breaker, and sparks are produced at the plugs. In the "OFF" position, the primary current is grounded and ignition prevented. The insulated post on this switch should be connected to the terminal on the breaker cover of the magneto. The switch itself is grounded through the metal dash on which it is mounted. In

case the switch is mounted on a wooden support, a ground wire should be run from one of the screws or bolts holding the switch in position to some convenient nut or bolt on the engine.

**127. The Splitdorf Aero Magneto with Impulse Starter.**—Figure 287 shows the Splitdorf Aero model 448 four-cylinder magneto fitted with the Splitdorf impulse starter. This equipment facilitates the starting of hand-cranked engines direct from the magneto. As in other impulse

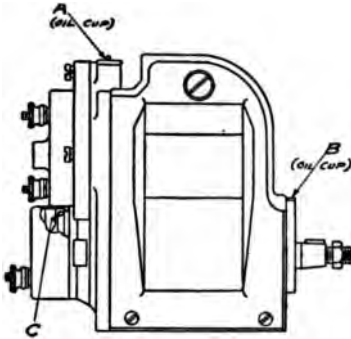

FIG. 284.—Side view of Aero magneto showing points to be oiled.



FIG. 285.—Point for oiling breaker arm on Aero magneto.

starters, this device permits the production of a strong magneto spark at the lowest possible cranking speed, or in other words, the action of the impulse starter may be compared to cranking the engine at about 500 turns per minute. A housing, Fig. 288, at the drive end of the magneto



FIG. 286.—Aero magneto control switch.



FIG. 287.—Aero Model 448 magneto fitted with impulse starter.

contains the operating parts of the impulse starter, and a small lever projects from the housing for the purpose of engaging the mechanism. Figure 289 shows the rear view of the magneto with the impulse starter cover removed. Figure 290 is a sectional view of the starter, showing details of construction and operation. The member *A* is keyed to the

drive shaft of the magneto and contains the notches *C* and *D*. The pawl *E* carries projections *F* and *G*, and is movable about the axis *H*. The cam member *J* has two cams, *K* and *L*, and also carries the trip lever *M*.

When the engine is being started, the parts of the starting mechanism



FIG. 288.—Rear view of Aero magneto showing impulse starter.



FIG. 289.—Rear view of Aero magneto with impulse starter cover removed.

rotate at low speed and the centrifugal force is not sufficient to throw the trip lever *M* out from the center; hence, the point *N* of the lever engages with the projection *G* of the pawl and causes projection *F* to engage with notches *C* and *D*.

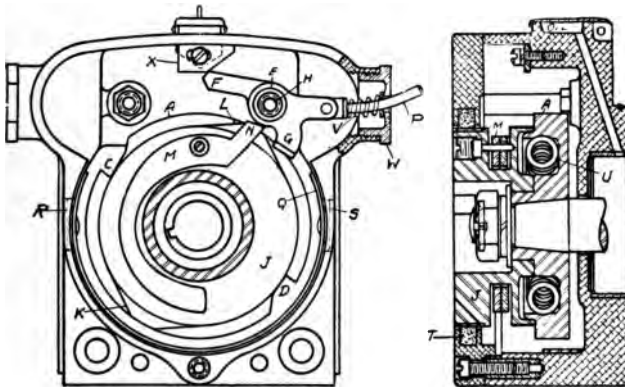

FIG. 290.—Sectional view of Aero impulse starter.

The member *A* is now prevented from turning, but cam member *J* continues to turn and compresses the coil spring *U* inside of *A* until cam *K* or *L* releases the projection *F*. The coil spring then causes the member *A* to rotate at high speed, carrying the magneto shaft with it, and producing a strong spark in the cylinder. This spark always occurs several

degrees past the upper dead center, regardless of whether the spark lever is advanced or retarded, thus making the starter safe.

The pawl projection *F* continues to engage in notches *C* or *D* until the speed reaches 150–200 r.p.m., at which speed the blow from the cam is sufficient to throw the pawl *E* against the stop *X*, to an inoperative position. At this speed, the trip lever *M* is thrown out by centrifugal force, so that it no longer engages with pawl projection *G*. This permits the engine to throttle down to idling speeds without the trip lever engaging. The lever *P* on the side of the housing is provided in order that the pawl *E* may be engaged by hand if necessary. The stop *X* is adjustable; moving it to the right permits the starter mechanism to come in or function at lower speed.

Figure 291 shows the coil springs used with the impulse starter and also the method of inserting a new spring. The longer spring is the main spring and the one which is compressed by the action of the starter, consequently driving the magneto shaft forward at the proper moment.



FIG. 291.—Springs used in Aero impulse starter.

On account of the strenuous service to which this spring is subjected, it sometimes breaks and must be replaced. A new spring can be easily inserted by putting a nail or pin through the opening in the side of the housing in the lateral hole of magneto member *A*, the ends of the spring being inserted in the recess first. The middle section can then be pressed in with ease. The smaller spring is provided as a cushion to take up the shock or jar produced by the rapid action of the mechanism.

Care should be taken never to throw the impulse starter into action when the engine is running, as grave damage may result to the operating parts.

**128. The Aero Magneto with Battery Starting Connections.**—The Aero magneto may be furnished with two terminals on the breaker cover, the second terminal being for the purpose of admitting battery current to the primary winding for starting. When so equipped, the four-cylinder magneto, Fig. 292, is known as model 449.

By introducing battery to the primary winding on the magneto, it is possible to obtain hot sparks when the magneto is making as low as 5 to 10 revolutions per minute. This introduction of the battery current facilitates the starting of the engine under difficult conditions and does not interfere with the regular operation of the magneto in any way. The wiring diagram for this arrangement is given in Fig. 293. The terminal marked *M* is connected to the insulated terminal on the starting motor. This allows the battery current to flow through the primary winding of the magneto when the starting switch is closed. Whenever the engine is

being started by the electric self-starting equipment, the battery sends current through the magneto windings, producing sparks the moment the engine turns over. When the starting switch is released, the end of the primary magneto winding which is usually grounded becomes grounded through the starting motor and the magneto operates in the usual way. The primary current flowing through these connections is of low voltage. The terminal marked *G* is connected to the magneto control switch for the purpose of cutting off the ignition to stop the engine. It is very essential that all connections be kept clean and tight.

**129. The Aero Magneto for Eight-cylinder Engines.**—The Aero magneto shown in Fig. 294, for eight-cylinder automobile engines, has a four-lobed rotor and produces two sparks per revolution of the magneto shaft. This requires that the magneto be driven at twice crankshaft speed to produce the four sparks needed for each revolution of the engine. The distributor is driven from the engine by a 2 to 1 gear reduction. The eight-cylinder distributor, Fig. 295, differs from the usual distributor in having the seg-



FIG. 292.—Aero model 449 magneto for battery starting.

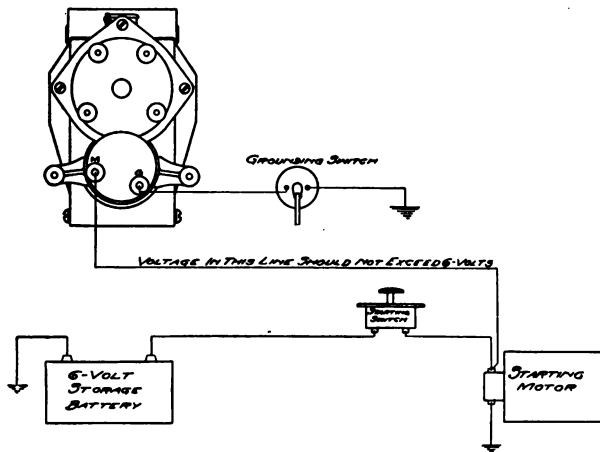

FIG. 293.—Wiring diagram of Aero magneto with battery starting.

ments arranged in two rows of four segments each, instead of in one row of eight segments. This construction permits of a very compact grouping of the distributor parts. The rotor, Fig. 296, has a double finger which makes contact with the two rows of segments.



The high-tension current from the secondary winding is collected by brush *C*, Fig. 296, which bears upon a brass plate on the coil assembly. This brass plate is the terminal of the secondary winding, and the brush *C* makes contact with this plate in all positions of spark



FIG. 294.—Aero magneto for eight-cylinder engines.

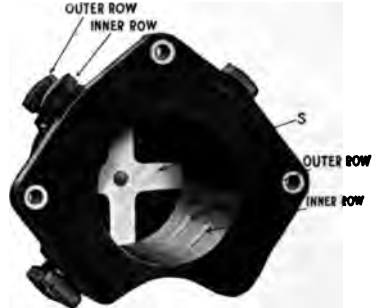

FIG. 295.—Aero eight-cylinder distributor.

advance. The high-tension current is conducted through the center of the rotor to brush *D*; then by means of the sector *S* in the distributor block, Fig. 295, the current is conducted to either of the two brushes, *A1* or *B1*. Brushes *A1* and *B1* are connected, respectively, to brushes *A2* and *B2*. Brushes *A2* and *B2* make contact with the distributor segments in the distributor block from which the cables lead to the spark plugs. The brushes *A1* and *B1* are placed alternately in electrical contact with the brush



FIG. 296.—Aero eight-cylinder rotor.



FIG. 297.—Aero twelve-cylinder magneto.



*D*. They become alive only at the moment when their companion brushes, *A2* and *B2*, are actually in contact with a segment in either of the two rows of segments on the distributor block. This arrangement makes it impossible for the spark to jump to the wrong segment. A spark received at any post of the inner row of the distributor block

will be followed by a spark from a post in the outer row of the block, which is  $180^\circ$  away from the post of the previous spark.

**130. The Aero Magneto for Twelve-cylinder Engines.**—The Aero magneto for twelve-cylinder automobile engines, shown in Fig. 297, has a six-lobed rotor and gives three sparks per revolution of the magneto shaft. It is driven at twice crankshaft speed to furnish the six sparks needed per revolution of the twelve-cylinder engine. The distributor, Fig. 298, which consists of two rows of six segments each moulded together in the distributor block, is driven at one-half the speed of the magneto shaft. The twelve-cylinder rotor, Fig. 299, is very similar to the eight-cylinder rotor, the only difference being in the size, and in the angularity of the brushes. In the twelve-cylinder model, a spark in the outer row of segments is followed by a spark in the inner row of segments at a post displaced  $120^\circ$  from the post of the first spark.

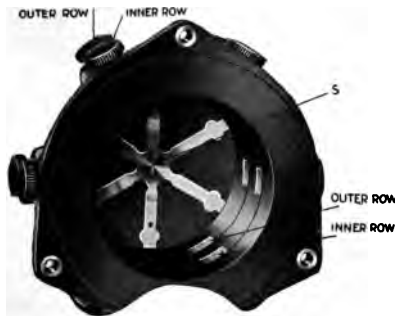

FIG. 298.—Aero twelve-cylinder distributor.

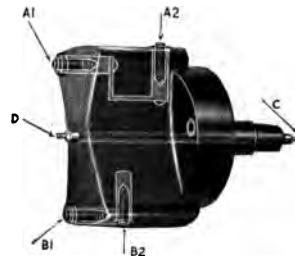

FIG. 299.—Aero twelve-cylinder rotor.

**131. The Aero Airplane Magneto.**—The Aero magneto, as developed for airplane use, is shown in Fig. 300. The construction differs somewhat from that of the other Aero magnetos which have been described, chiefly in the arrangement of the distributor and in the shape of the magnets. The segments of the distributor are all in one row and the distributor rotor has but one finger or brush which makes contact with the distributor segments. The interior view of the eight-cylinder airplane magneto, model 825, is shown in Fig. 301. This illustration shows the magnets of the airplane models to be square in shape instead of having a circular bend as in the automobile type. The design of the breaker box has been changed to provide for the increased size of the parts needed in airplane service. The terminal shown on the side of the magneto in Fig. 301 is provided for tapping off current from the magneto for use in wireless telegraphy.

An interesting method is employed in getting high-tension current for starting. At the ordinary cranking speed of airplane engines, the

magneto is revolved too slowly to give a good igniting spark. In the Aero airplane ignition system, a second high-tension magneto known as model 100 is provided for cranking. Figure 302 shows model 100 and model 825 eight-cylinder magnetos as they are used on airplane engines. The auxiliary starting magneto may be turned by hand by



FIG. 300.—Aero model 825 airplane magneto.



FIG. 301.—Interior view of Aero model 825 magneto.

the small crank, or it may be connected by gearing to the starting crank of the engine. In the first case, an attendant turns the starting magneto while the engine is being cranked. In the second case, the cranking of the engine automatically turns the starting magneto at a high rate of speed. The starting magneto generates four sparks per revolution of the

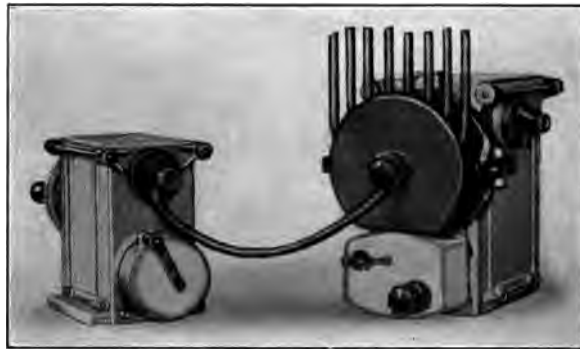

FIG. 302.—Aero model 100 starting magneto with model 825 airplane magneto.

magneto shaft. These sparks are introduced to the distributor of the regular magneto and from there are sent to the spark plug in that engine cylinder which happens to be in the firing position at that instant. The use of the starting magneto thus gives a stream of high-tension sparks *in the cylinder* of the engine. The heating effect of the several sparks

which occur in each cylinder is such that the gas in the cylinder is readily exploded and the engine starts quickly. As soon as the engine fires and comes up to speed, the regular magneto takes up its work and the starting magneto is stopped.

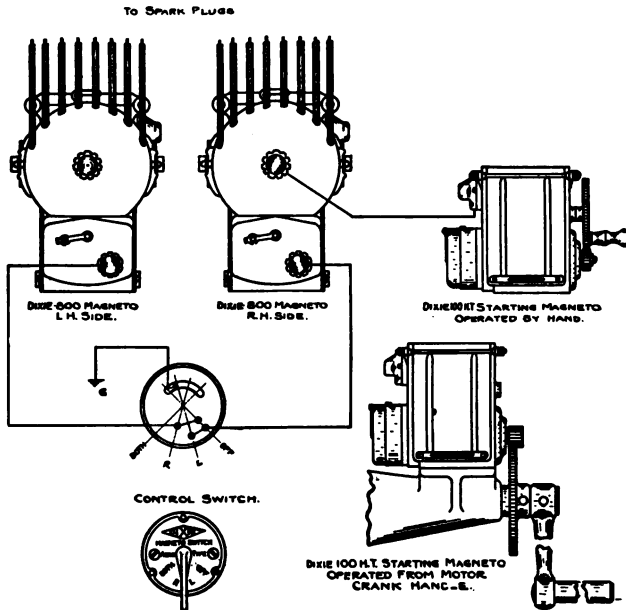

Fig. 303.—External wiring diagram of Aero model 800 ignition system for aircraft with hand starting magneto.

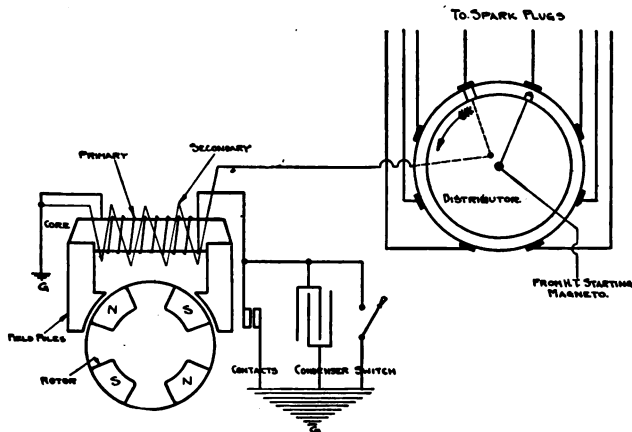

Fig. 304.—Internal wiring diagram of Aero aircraft type magneto.

Figure 303 is the external wiring diagram of the system applied to an eight-cylinder airplane engine. Two main magnetos are employed, each having a set of spark plugs in the engine. The magneto control switch

is arranged so that either or both of the main magnetos may be used for ignition. When both are used, the gas in the cylinder is ignited from two widely separated plugs, resulting in a quicker burning of the gas and a more powerful and speedy engine. The starting magneto is connected to but one of the main magneto distributors. The figure shows the hand-turned starting magneto and also the method of driving it from the starting crank. The internal wiring diagram of the Aero magneto is shown in Fig. 304.

**132. Aero Magneto Adjustments.**—The timing of the Aero magneto is taken care of by the adjusting of the breaker points and the setting of the rotor edge distance. The airplane types also have the additional adjustment of the distributor finger or brush.

As in all magnetos, the breaker points of the Aero magneto should separate at the instant the spark is desired in the cylinder. Before this



FIG. 305.—Buzzer test set for setting rotor edge distance.

adjustment can be made, the rotor edge distance should be checked and adjusted. This can be accomplished by the use of a thickness gage and a buzzer test set.

A buzzer test set is shown in Fig. 305. It consists of a case containing two dry cells with an electric buzzer mounted on the top. The buzzer is connected to the dry cells, and the circuit is brought to the two binding posts at the top of the case. Any metallic connection between the two binding posts will operate the buzzer.

The magnet cover, magnets, winding, rotor cover, breaker cover, and condenser should be removed from the magneto whose edge distance is to be tested. A lead should be run from one of the binding posts on the buzzer set to the post that is fastened to the contact screw bracket of the magneto, and another lead should be run from the other binding post on the buzzer set to the post extending from the breaker base. These

leads are shown in place in Fig. 306. The rotor shaft should be turned in the direction indicated by the arrow on the drive end plate until the buzzer does not vibrate. The shaft should be held in this position and the distance of the rotor from the field pole checked; this distance should be from .050 in. to .075 in. This distance is measured between the field pole and the rotor lobe that is leaving and not the one that is approaching the pole.

If this distance is not within the limits mentioned above, the three slotted round nuts that hold the breaker to the magneto should be loosened and the breaker turned to the right or to the left until the proper edge distance is obtained. The three nuts should be tightened securely and the edge distance rechecked. If correct, the cupped washer should be staked in the slots in the nuts.



FIG. 306.—Setting rotor edge distance on Aero magneto.

After the rotor edge distance has been properly adjusted, the breaker points should be adjusted to open .018 in. to .022 in. when the highest point of the breaker cam is in contact with the fiber bumper on the breaker arm. The rotor edge distance should be rechecked again and, if found correct, the magneto may be reassembled.

The adjustment of the distributor brush in the airplane magneto is made necessary because of the introduction of the high-tension current from the starting magneto at this point. The carbon brush should be entirely on the segment, when the breaker points open, but it should not be so far on the segment that the rear edge of the brush is further than  $\frac{3}{16}$  in. from the edge of approach of the segment. The carbon brush should not overlap the segment; if it does, the brush should be beveled

to the edge of the segment. This adjustment is pictured in Fig. 307. The small views at the side show the proper condition.

Where two magnetos are used on the same engine, one of them should be adjusted so that the firing point conforms to the setting recommended by the manufacturer of the engine. The other magneto should then be synchronized with the first so that both magnetos will produce sparks

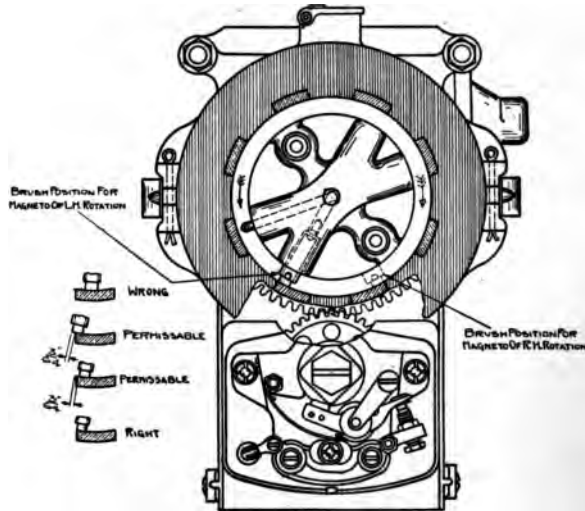

FIG. 307.—Setting the distributor brush on Aero magneto.

at exactly the same instant. This synchronizing should be made by means of adjustable couplings and not by the adjustment of the breaker points of the magneto. This adjustment should be checked at frequent intervals since the advantage of having two points of ignition in each cylinder is lost if the two sparks occur as much as  $\frac{1}{10,000}$  of a second apart.

## CHAPTER IX

### CARE AND REPAIR OF IGNITION APPARATUS

**133. Methods of Mounting Ignition Apparatus.**—Ignition equipment must always be driven at some definite gear ratio to the engine. This is accomplished by driving the apparatus by a chain or gears from the crankshaft of the engine. The number of teeth on the sprockets or gears is such that the proper gear reduction is obtained. The four-stroke cycle engine requires an explosion in each cylinder every two revolutions

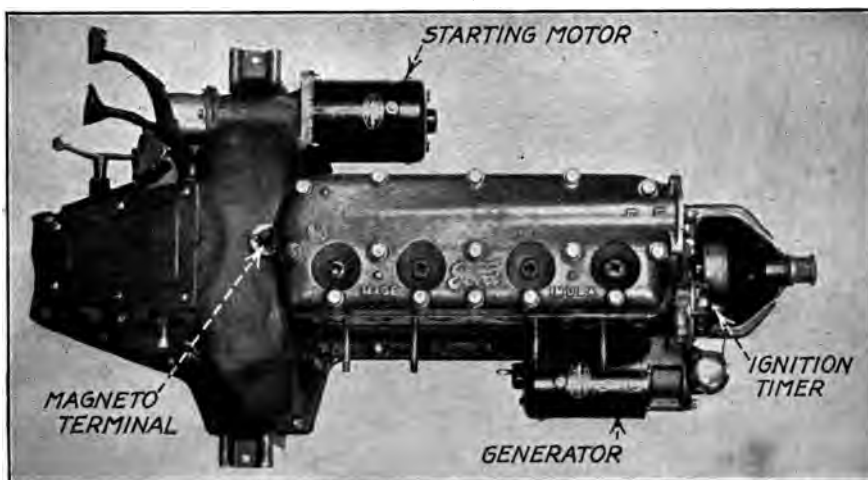

FIG. 308.—Ford engine showing location of timer.

of the crankshaft; thus every cylinder on the engine is fired during two complete revolutions of the crankshaft. The order in which the cylinders fire is called the "firing order" of the engine. The timer or the distributor directs the current so that each cylinder gets a spark in the proper order.

*The Vibrating Coil-timer System.*—A typical example of this type of ignition system is that installed on the Ford engine. The timer is located at the front end of the engine, as shown in Fig. 308, and is driven by an extension of the camshaft. With the exception of the low-tension magneto, the timer is the only moving part of the Ford ignition system. The magneto, however, simply acts as a source of low-tension current for the ignition system and has nothing to do with the distribution of current. In fact, the magneto may be replaced by an electric battery, either dry cells or storage, and the system will function the same as before. The



low-tension current is conducted from the timer terminals to the four vibrating coils mounted on the dash. The high-tension current generated in the coils is taken to the spark plugs in the cylinders by heavily insulated high-tension cables.

*The Non-vibrating Coil Distributor System.*—In the battery ignition systems employing a single non-vibrating coil with a distributor in the high-tension circuit to direct the high-tension current to the proper spark plugs, the distributor must be driven at one-half crankshaft speed. The cam operating the interrupter is usually mounted on the distributor shaft and has as many points as there are cylinders on the engine. The interrupter and distributor unit is mounted vertically and driven by "one to one" gears from the camshaft of the engine. Figure 309 shows the Delco ignition system as installed on the Nash Six engine. The igni-

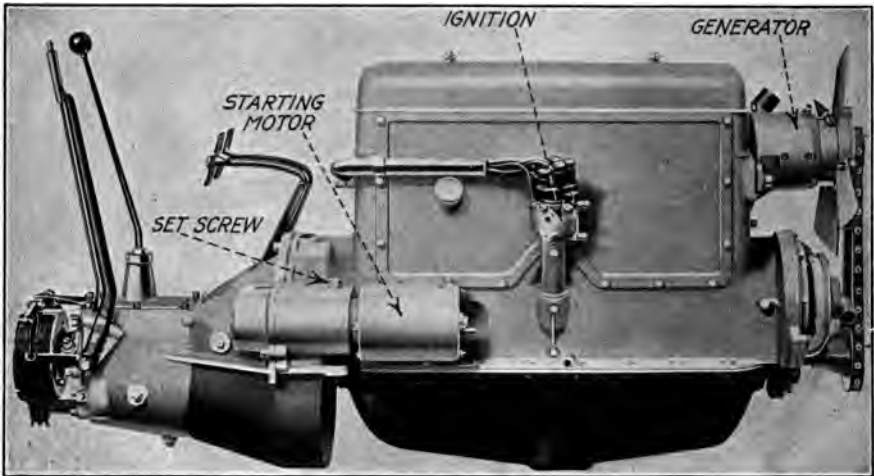

FIG. 309.—Delco ignition unit on Nash Six.

tion unit, consisting of the interrupter and distributor, is shown on the side of the engine. The shaft of the unit extends down into the crank case of the engine. At the lower end of this shaft is a spiral gear which meshes with a spiral gear of the same size carried by the camshaft. The high-tension cables leading from the distributor to the spark plugs are placed in the metal tube shown passing around to the left of the engine cylinder block. The non-vibrating coil and the ignition control switch are mounted on the dash.

Another common method of mounting the interrupter-distributor ignition unit is shown in Fig. 310. The ignition unit is carried at one end of the electrical generator and is driven by spiral gears from the generator shaft. The generator in turn is driven by the train of gears in the timing gear case of the engine. The engine is shown with the timing

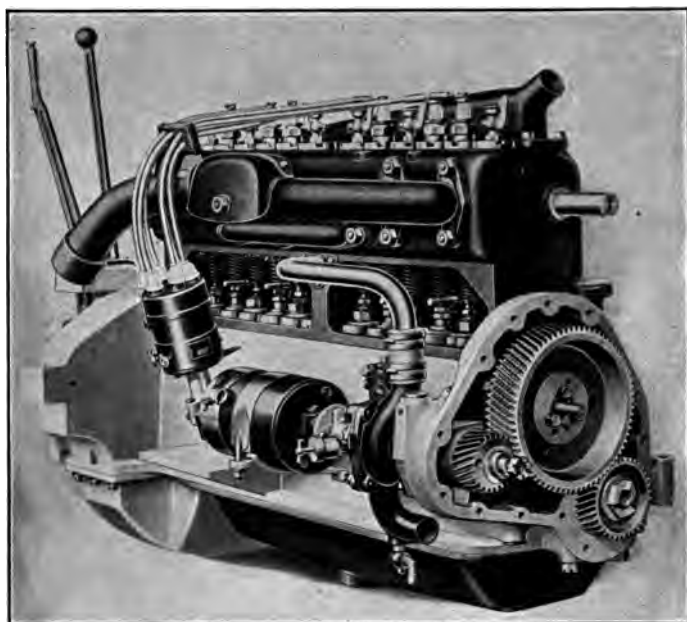

FIG. 310.—Case continental engine showing Westinghouse ignition unit mounted on generator.

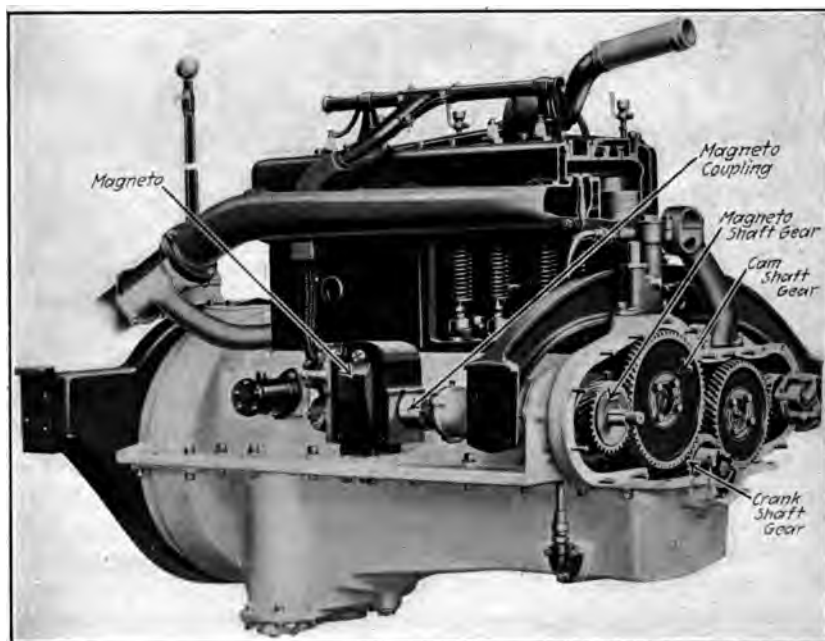

FIG. 311.—Magneto installation on Packard Model E truck engine.

gear case cover removed. The lower gear is mounted on the crankshaft of the engine; the large gear above is the camshaft gear; the small gear to the left is the generator and pump shaft gear. The crankshaft gear has 36 teeth; the generator gear has 24 teeth; consequently, the generator is driven at  $1\frac{1}{2}$  times crankshaft speed. The ignition unit must revolve at one-half crankshaft speed, and, therefore, has a 3 to 1 reduction at the spiral gears on the distributor and generator shafts.

Other methods of mounting the distributor unit are shown in Figs. 89, 102, 156, 160, 163, and 167. A study of these illustrations will indicate the method of obtaining the convenient mounting and correct gear reduction required for this class of ignition equipment.

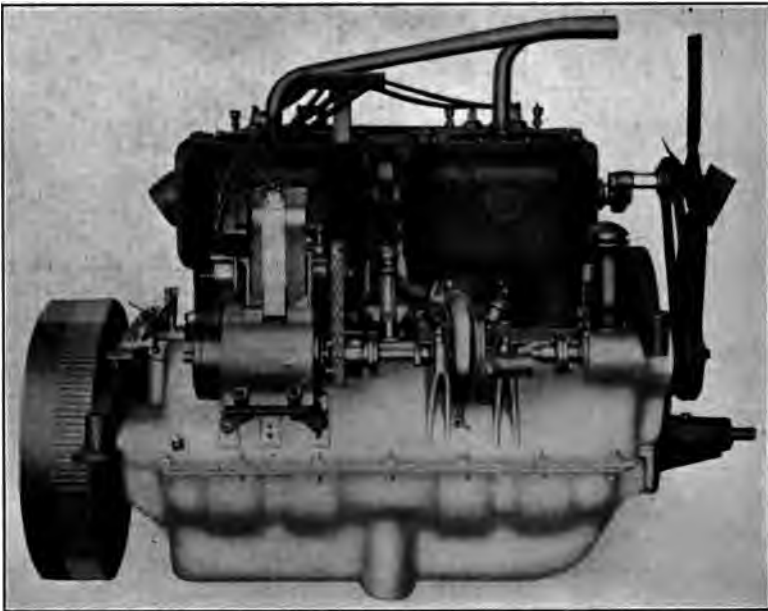

FIG. 312.—Chain driven magneto on Continental engine used on the  $3\frac{1}{2}$  ton Oneida truck.

*Magneto Drives.*—The magneto is usually mounted with the shaft horizontal and is driven by a gear meshing with the camshaft gear at the front end of the engine. Figure 311 shows the magneto installation on the Packard model E truck motor. The magneto is mounted on a bracket on the right side of the engine crank case and is driven by a gear meshing with the camshaft gear as shown. The high-tension cables are protected by a tubular container. The only part of this ignition system not shown is the control switch mounted on the dash.

On some engines, the magneto is chain driven, as shown in Fig. 312, which illustrates the Continental engine used on the  $3\frac{1}{2}$  ton Oneida

truck. The magneto is mounted above the electrical generator and is chain driven from the pump shaft which also drives the generator.

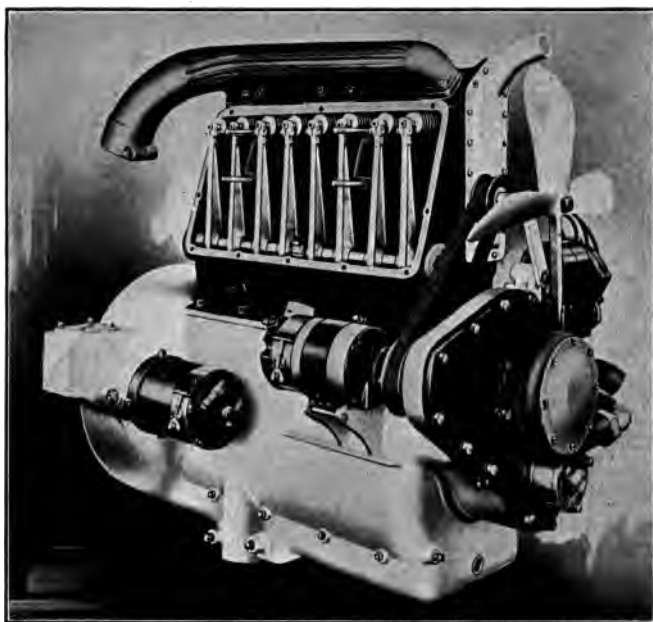

FIG. 313.—Magneto mounting on Duesenberg engine.

Figure 313 shows the magneto mounting on the Duesenberg engine. The magneto is driven by a transverse shaft at the front end of the engine.

**134. Magneto Couplings.**—The engine is always provided with a bracket to which the magneto is fitted. A suitable shaft drives the magneto. Due to the difficulty of lining up the center of the magneto shaft with the center of the drive shaft, a flexible coupling is provided between the ends of the two shafts. This flexible coupling allows the magneto to be driven satisfactorily even with the two shafts considerably out of alignment. The flexible coupling acts as a universal joint.

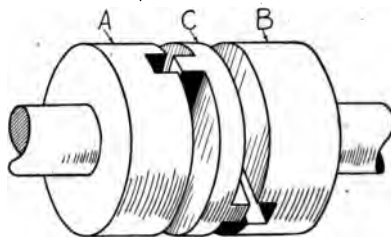

FIG. 314.—Oldham flexible coupling.

A flexible coupling often used for magneto drives is the Oldham coupling shown in Fig. 314. The Oldham coupling consists essentially of three parts, the end pieces *A* and *B* and the center piece *C*. One of the end pieces is fastened to each of the two shafts to be coupled. These pieces each have a slot cut across their opposing faces. The center piece

*C* has two splines, one on either side, at right angles to each other. When the joint is assembled, the piece *C* is held between the two end pieces and cannot escape. The power is readily transmitted through the three parts, the construction of which permits of some angularity between the two shafts.

A very efficient type of magneto coupling is shown in Fig. 315. In this coupling each of the two shafts to be joined terminates in a forked member. This member has a hole in each end and is bolted to a heavy leather or fiber disc. The second forked member is fastened to this disc at right angles to the first. This construction permits the coupling to accommodate itself to any angularity that might be present between the two shafts and at the same time the flexible nature of the disc enables the coupling to absorb the mechanical shocks which might otherwise be transmitted to the magneto from the engine. This coupling needs very little attention and no lubrication.

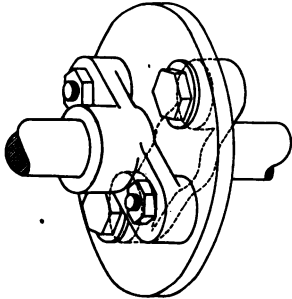

FIG. 315.—Flexible disc coupling.

The Uniflex flexible joint, Fig. 316, is also adaptable for driving a magneto. The joint consists of two shaft members and a set of blocks. The shaft members are jawed hubs, so designed that they engage with each other through the blocks. The blocks are built up of six sections and may be faced with fiber, wood, or any other material used for magneto drives. When the sections are covered in this way, the joint is insulating and shock absorbing and requires little lubrication.

**135. Bearings and Lubrication.**—The moving parts of an ignition apparatus must of necessity be of light construction and must rotate at high speed. These parts are, therefore, provided with the best grade of anti-friction bearings. The ball bearing lends itself admirably to this type of service and is generally used, although some battery ignition units have plain bearings lined with bronze or other anti-friction metal.



FIG. 316.—The Uniflex coupling.

The magneto armature shaft and the distributor shaft are mounted upon ball bearings as shown in Fig. 317. These bearings must be adjusted very accurately so as to carry the shafts exactly in the correct position. The clearance between the armature core and the pole pieces is but a few thousandths of an inch; consequently, the armature *shaft bearings* must hold the armature exactly centered between the

pole pieces. Any departure from this central position will cause the armature core to rub on the pole pieces, rapidly rendering the magneto useless. Bearings used for this service are very accurately made, and should be given care and attention worthy of their fine construction.

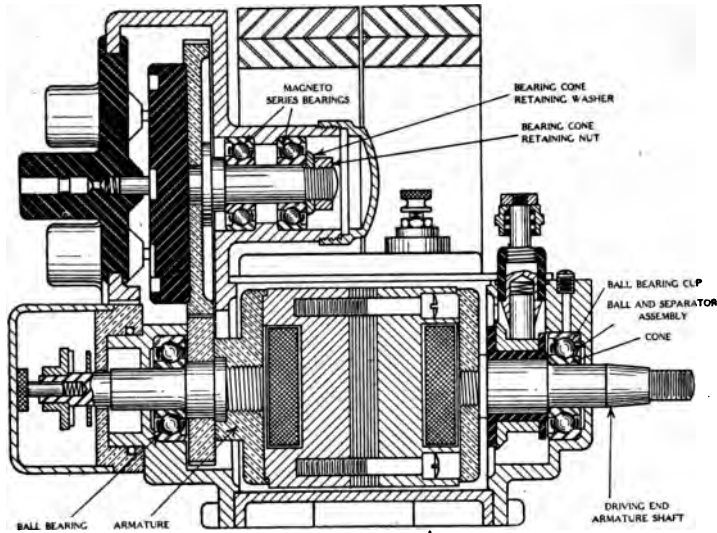

FIG. 317.—Sectional view of magneto showing method of mounting ball bearings.

Figure 318 is a cross section of a magneto bearing, showing the arrangement of the parts. The balls roll on an inner race which is called the "cone;" the outer race is called the "cup." The shape of the cup and the cone permits the bearing to take a certain amount of side thrust, preventing any end play or side movement of the armature.

*Lubrication.*—The lubrication of the bearings of an ignition apparatus is very important. The bearings must be supplied with enough oil to lubricate them properly, but they must not receive an over-supply since too much oil on electrical equipment is certain to cause trouble. This is especially true of those parts which carry current, such as the breaker points and the distributor segments. The moving parts in the breaker mechanism should be oiled with but a small drop of thin oil about once a month. The distributor needs very little oil carefully applied.

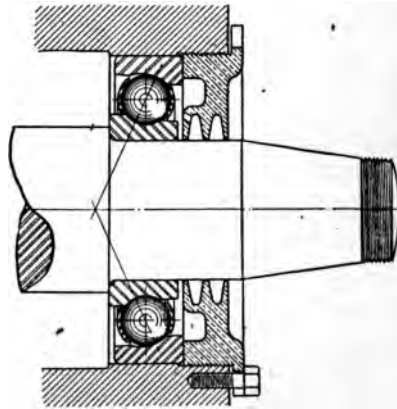

FIG. 318.—Cross section of magneto ball bearing showing angular contact.

should be cleaned about once a month with a cloth slightly dampened with a good grade of vaseline. This will remove any carbon dust which may have been worn from the carbon fingers and will leave a thin film of oil to lubricate the surface over which the brush slides.

The bearings of the distributor shaft in battery ignition units and the bearings on the armature shaft of magnetos should receive a few drops of thin oil about once each month. Not more than a few drops should be applied as any surplus oil will find its way into the windings and other parts of the electric circuit and will destroy the insulation and cause short circuits and other troubles. The oil holes leading to bearings of this nature are usually supplied with felt wicks which will absorb only a few drops of oil; any additional amount will simply run over the outside of the oil cup, and escape. The wick feeds the oil to the bearing very slowly over a long period.

It may be said in connection with the oiling of an ignition apparatus that a little oil supplied often is of more value than a larger quantity applied at longer intervals. The care and attention given to the ignition apparatus in this respect will result in improved performance. Oil which contains graphite should never be used as graphite is a conductor of electricity and will find its way into places where it will cause trouble by short circuits.

**136. Impulse Starters.**—Impulse starters are subjected to very hard service. Care should be taken to keep them free from dirt, and well lubricated at all times. Ordinary gas engine cylinder oil, such as is used for lubricating the engine on which the impulse starter is used, is excellent for this purpose. The starter should be taken apart occasionally, and the parts cleaned and examined closely for wear. Any worn or defective parts should be replaced with new ones. The springs, especially, should be replaced as soon as any indication of wear appears. The work of the impulse starter subjects these springs to such severe usage that one is apt to break at any instant without previous notice of failure. Consequently, a few extra springs should be kept on hand.

**137. General Rules for Magneto Timing.**—The four-stroke cycle gasoline engine used on automobiles goes through a series of operations requiring four strokes of the piston, or two revolutions of the crankshaft. Figure 319 represents these two revolutions so as to show the position of the crank when the different events occur. The diagram is drawn for a vertical engine with the crank revolving to the left as indicated by the arrow. This is the direction of rotation of an automobile engine to a person standing in front of the car looking toward the engine.

Let it be assumed that the engine piston has reached the top of the stroke and has started down on the return stroke. The crank of the engine will also be moving down until the crank angle is approximately  $10^{\circ}$ , when the inlet valve opens. The suction stroke of the engine then

takes place, the inlet valve closing about 20° to 30° past the lower dead center. The inlet valve has, consequently, been open 180° to 200°. As the crank moves on, the gas is compressed, both valves being closed. From 5° to 10° before the upper dead center is reached, the gas is ignited and the burning or combustion occurs during a period of from 5° to 10°. The full force of the explosion is exerted just as the crank passes the upper dead center and the piston begins to descend. The expansion of the gas now takes place. From 30° to 45° before the lower dead center, the exhaust valve opens, permitting the gases to be forced out of the cylinder. The exhaust valve closes a few degrees past

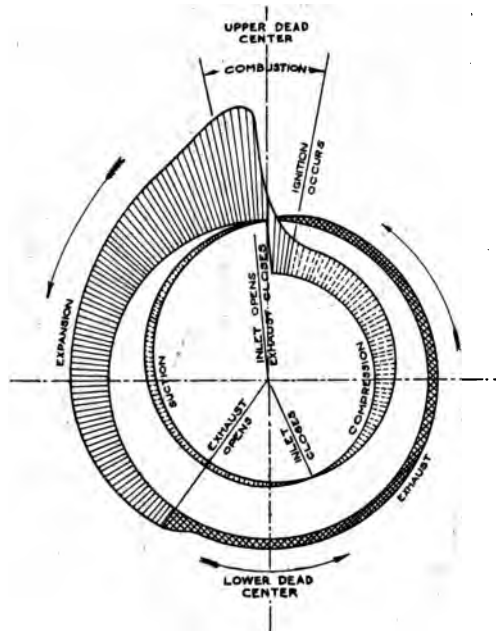

FIG. 319.—Order of events in the four-stroke cycle engine.

the upper dead center. One complete cycle has now been completed and the engine immediately enters upon a second cycle.

The above description of events which take place in the four-stroke cycle engine is for the normal running of the engine after it has been started. While the engine is being cranked for starting, it is necessary that the ignition point be delayed until the piston has passed the upper dead center. This is because of the fact that while the engine is being slowly turned by hand or by the starting equipment, an explosion in the cylinder before the piston has reached the upper dead center will drive the piston backwards. This is apt to injure the person cranking the engine, or damage the starting mechanism. The ignition point is delayed until the piston has passed the upper dead center by retarding



*the spark.* After the engine is started, the spark is *advanced* until it is again taking place at the point shown in Fig. 319. The combustion of the mixture of gasoline vapor and air in the cylinder does not take place instantaneously, as is commonly believed, but requires a fraction of a second for its completion. During this short interval of time the piston may move a considerable distance, especially if the engine is running at a high speed. It is for this reason that the spark must take place a few

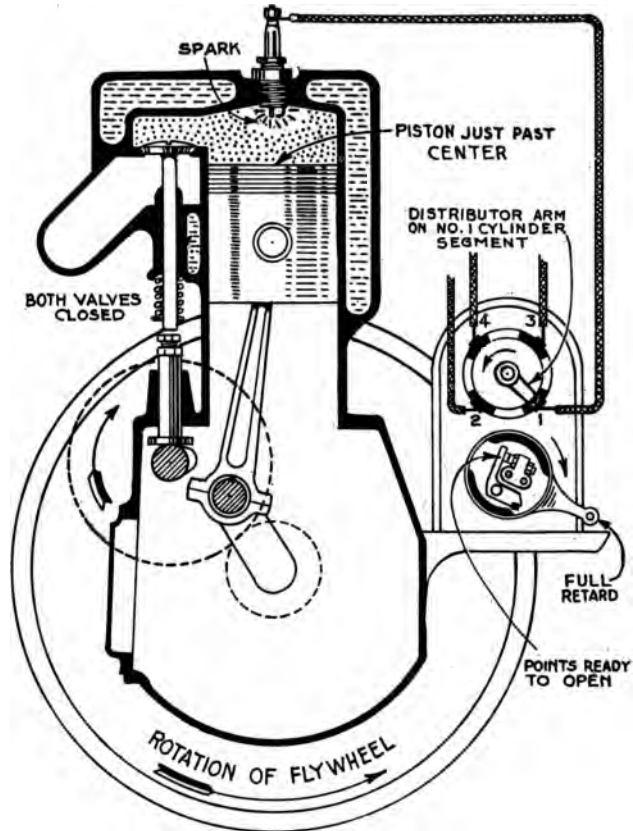

FIG. 320.—Timing the magneto to the engine.

degrees before the upper dead center, as shown in the diagram, to allow time for the mixture to burn and the full pressure to develop before the piston starts down on the working stroke. The faster the engine is running the farther the spark must be advanced. An engine running slowly must have a retarded spark. These conditions require that the time of the spark in the cylinder be under the control either of the driver or of an automatic spark advance mechanism.

*Magnetos* installed on engines must be adjusted to produce the spark

in the cylinder at the proper instant. This adjustment of the magneto is called *timing*. Figure 320 shows a cross section of cylinder No. 1 on a gasoline engine with the parts in the proper position for the occurrence of the spark. The piston has just passed the upper dead center. The mixture of gasoline vapor and air in the cylinder has been compressed into the clearance space at the top of the cylinder. Both valves are closed since this is the beginning of the working stroke. With the engine in this position, the magneto should be timed. The flexible coupling driving the magneto should be loosened and the magneto shaft turned in the direction of its normal rotation until the rotating brush in the magneto distributor is on the distributor segment marked "No. 1." This is the segment from which the cable leads to the spark plug in cylinder No. 1. With the spark lever in the fully retarded position, the magneto shaft is turned slowly until the contact points in the breaker box are just separating. The magneto is held carefully in this position while the coupling is being tightened. The other spark plug cables are then attached to the distributor terminals in the order of firing of the cylinders of the engine. With the spark lever in the fully retarded position, the magneto will deliver a spark to the cylinder late enough for safe cranking, while the early spark required for high speed operation may be had by advancing the spark lever.

**138. General Rules for Battery Ignition Timing.**—The usual form of battery ignition used on most automobile engines is the type using the single non-vibrating coil with an interrupter and a distributor. The same rules apply to this type of ignition equipment as apply to the magneto. The engine is set with the piston in No. 1 cylinder on the upper dead center on the working stroke. The distributor shaft is turned until the brush is on segment No. 1 and the contact points are just opening, with the spark control lever in the fully retarded position. The distributor drive shaft is fixed in this position, either at the coupling or by meshing the driving gears. The cables from the distributor segments are then attached to the proper spark plugs, according to the firing order of the engine, and the timing is complete.

*Timing the Ford Ignition System.*—The timing of the vibrating multiple coil and timer ignition system with the engine is somewhat different from the method employed in the systems just described. The ignition system used on the Ford automobile is a good example of this type. Figure 321 shows the position of the various parts when the Ford ignition system is correctly timed. As before, the engine is set with the piston in No. 1 cylinder just past dead center at the beginning of the working stroke. The camshaft gears driving the timer arm are demeshed and shifted until, with the timer in the retarded position, the roller arm is at the point where the roller is just making contact with the timer segment carrying the insulated wire which runs to the coil for cylinder No. 1. The

gears are then meshed and the remaining wires from the timer segments connected to their respective coils. At the instant the roller makes contact with the timer segment, a shower of sparks begins in the cylinder and lasts as long as the roller is on the segment. Ignition, therefore, occurs when the timer *makes* contact and not when the contact is *broken*, as is the case in the non-vibrating coil systems.

**139. Care and Adjustment of Breakers and Timers.**—The breaker or interrupter is depended upon to break the circuit at the exact instant ignition is desired in the cylinder of the engine. In order that it may fulfill this function properly, the separation of the breaker points should

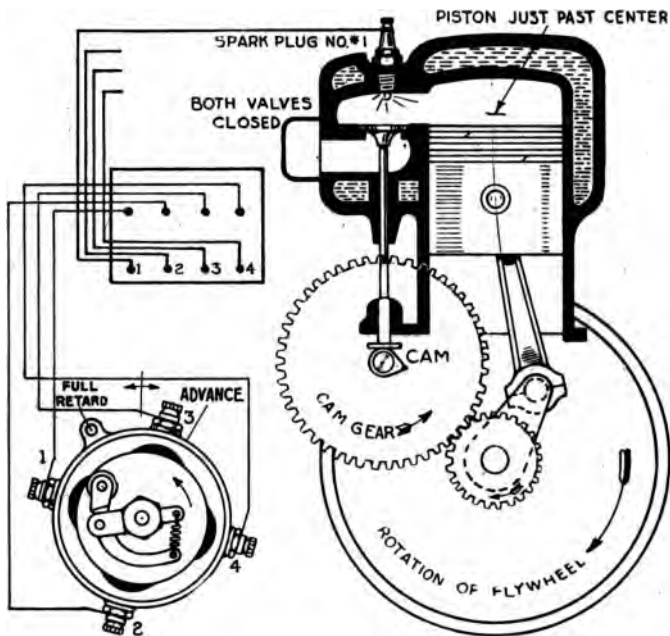

FIG. 321.—Timing the Ford ignition system.

be adjusted to that distance recommended by the manufacturer—generally  $\frac{1}{50}$  in. or .020 in. when the contact arm fiber block is on the highest part of the cam. The contact points should be dressed off with a fine file or oil-stone to give a smooth flat contact. When the opening of the points has been properly adjusted, the contact point and lock nut should be set up tightly to prevent any possibility of loosening. A loosened lock nut will permit the points to work apart, thus throwing the ignition out of time. The tension of the spring which brings the points together should be sufficient to close the contact with a firm pressure. If this spring tension is too light, the points will not make good contact and the ignition will be erratic. The contact arm fiber block should be

replaced when it becomes worn. The contact arm pin must be lubricated slightly about once each month to prevent wear at this point. A

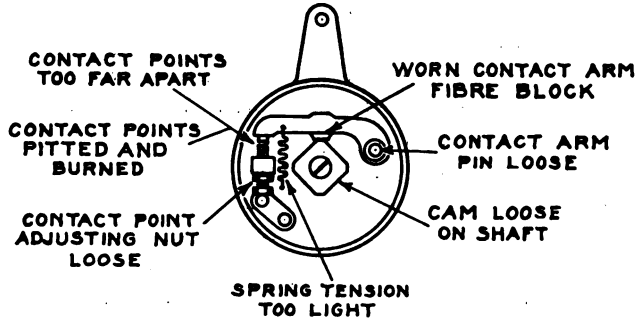

FIG. 322.—Conditions causing interrupter trouble.

worn pin should be replaced with a new one. The cam must be tight on its shaft, since a loose cam will shift on the shaft and cause the ignition to be thrown completely out of time.

The conditions just mentioned are shown in Fig. 322. Any improper timing will generally be caused by one or more of these conditions. Figure 323 shows the method of adjusting the contact points in one make of interrupter. A small wrench to fit the adjusting nuts is furnished. This wrench has two thickness gages pivoted to the handle. One of the gages is used in setting the contact points in the breaker and the other is used in setting the air gap in the spark plugs.

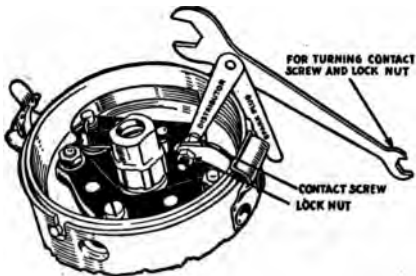

FIG. 323.—Adjusting interrupter contacts.

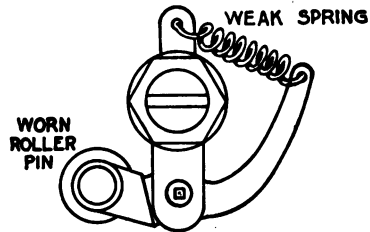
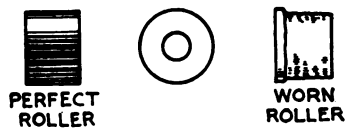
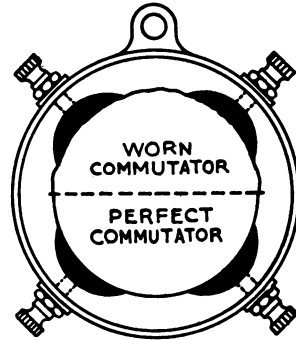

FIG. 324.—Conditions causing trouble in the Ford timer.

Figure 324 shows the troubles which may be experienced with the Ford timer. The timer carries four contact blocks imbedded in hard

fiber insulation. The roller on the timer arm rolls around this fiber track coming into contact with the contact blocks in the proper firing order of the engine. The fiber and the metal of the blocks wear down unevenly, making a series of irregularities or "bumps" over which the roller must pass. These bumps sometimes cause the roller to jump over the blocks without making contact, especially at high engine speeds, causing irregular ignition. Although it is possible to machine the fiber track and metal contact blocks smooth again, the cost of this operation is so high that it is more economical to replace that portion of the timer. The roller itself will wear loose on its pin and will sometimes wear rough on its outer surface. When either of these conditions is present, the complete timer arm should be replaced. The timer spring must be strong enough to exert considerable pressure between the roller and the fiber track. A weak spring will not cause positive contact between the roller and the contact blocks and should be replaced with a stronger spring.

**140. Wiring and Terminals.**—The units which compose the ignition system should be carefully connected into the circuit according to the instructions issued by the manufacturers. This information can always be found in the instruction book which accompanies the automobile when it is sold. In the absence of a manufacturer's instruction book, the wiring diagrams given in this book may be used as they are based on reliable information furnished by the makers of the equipment described.

Many ignition systems use the single wire wiring system; that is, one side of the battery is grounded and the circuit is carried from the other side of the battery to the switch, the interrupter, and the coil. The other terminal of the coil being grounded completes the primary circuit through the metal parts of the automobile back to the battery. Instead of taking advantage of the "ground" to carry the current back to the battery, some makers of ignition equipment use a second wire, called the return wire, to complete the primary circuit back to the battery. The secondary circuit is always grounded at the coil and at the spark plugs.

The wire used for wiring up the ignition system must be a good grade of heavily insulated stranded copper wire made especially for this purpose. The wire is stranded instead of being made of one large piece to prevent breaking, as a stranded wire will stand more vibration without breaking than a solid wire. Stranded wire will also stand more handling without injury than a solid wire. Figure 325 shows four grades of ignition cable, three of which are for use in a high-tension circuit and the fourth in a low-tension circuit. The voltages encountered in the high-tension circuit are sufficient to cause an electric spark to jump across a  $\frac{1}{4}$  in. air gap. For this reason, the insulation on high-tension cables must be very thick. The upper cable in Fig. 325 is heavily insulated for severe high-tension service, such as might be encountered on farm tractors where the wiring is exposed to the weather. In order that the rubber

insulation may be protected from abrasion, the cable is provided with a heavy braided fabric covering. The second cable is less heavily insulated, but has the braided covering and is suitable for the average high-tension installation. The third cable has the same thickness of rubber insulation as the second, but the fabric covering has been left off. This cable is often used where the wiring is well protected. Under such conditions it gives good service. The bottom cable is lightly insulated and is suitable for use in the primary circuit.

While the stranded cable will withstand much abuse without injury, it occasionally happens that the copper conductor will be broken within the insulation. A break of this kind is very hard to detect, because the insulation is heavy and the stranded wire is relatively light. In case of doubt it is well to remove the suspected piece of cable and substitute a length

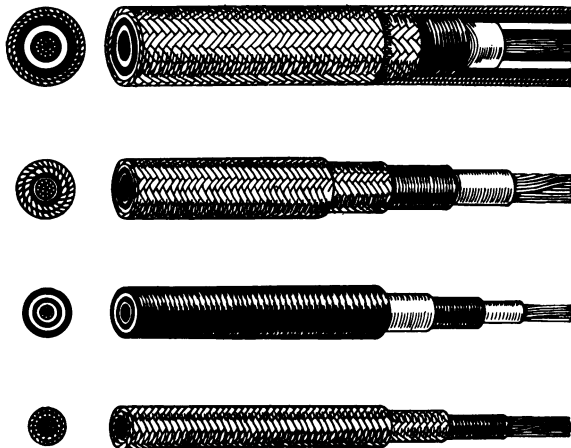

FIG. 325.—Cables for ignition service.

known to be perfect. If no improvement is noted in the system, the suspected piece of cable may be returned to the circuit.

The ends of the cable are provided with terminals as shown in Fig. 326. These terminals protect the ends of the cable and furnish a permanent fastening at the binding posts of the ignition units. They are provided with projecting lips which are crimped around the insulation of the cable. Smaller projections are crimped around the stranded conductor itself to furnish good electrical contact between the conductor and the terminal. Before crimping, the strands of the cable are passed through the hole in the shank of the terminal and twisted around and soldered to the body of the terminal. A common type of terminal is shown in Fig. 326A. The end is placed over the binding post and the nut screwed down tight. In Fig. 326, B shows a terminal having a forked end. The nut on the binding post to which the cable is to be attached

need not be removed from the post, but only unscrewed a short distance so that the terminal can be slipped under it. When the nut is tightened, the bent up projections on the end of the terminal keep it in place. Figure 326 C shows another type of terminal with both open and closed ends. It illustrates how the clips are bent around the outside of the insulation.

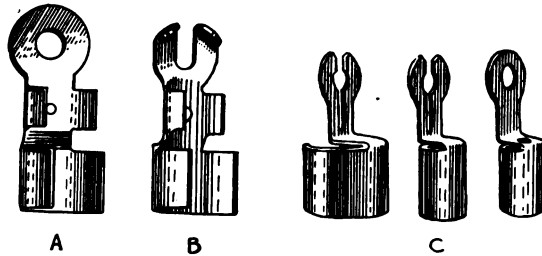

FIG. 326.—Terminals for ignition service.

In the absence of a proper terminal, good service may be obtained by the method shown in Fig. 327. This shows the end of a cable with the insulation cut back from the end so as to expose about two inches of the stranded conductor. The strands should be separated into two equal portions as shown at B. Each half is then twisted as in C, and the two parts bent to form a circle large enough to slip over the bind-

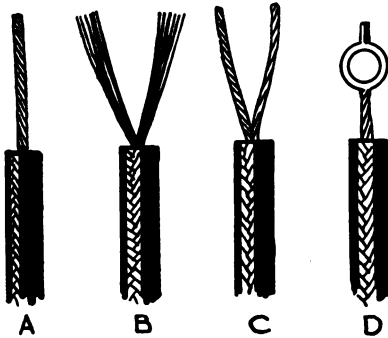

FIG. 327.—Method of making temporary terminals.

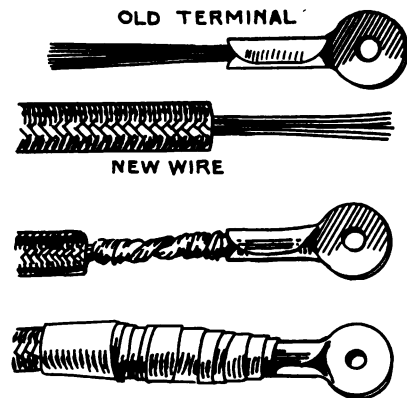

FIG. 328.—Method of using old terminals on new wires.

ing post easily as in D. The strands are then soldered together. This makes a stiff firm ending which will last some time.

In replacing cables, when no new terminals are at hand, the old terminal may be made to serve as shown in Fig. 328. The old terminal is cut off of the old cable, leaving about two inches of the conductor attached. The insulation is removed from the new wire for two inches

and the two wires twisted together. After the joint has been well wrapped with friction tape, the terminal is ready for service.

When making connections in wiring of this nature, it is of the utmost importance that good electrical contact be secured between the two parts which are joined. For this reason, the parts should be carefully cleaned and scraped to insure close metallic contact. They should then be soldered together. The smallest quantity of solder consistent with good workmanship should be used. The process most often employed is known as "sweating" the parts together. This is accomplished by applying the soldering flux to the parts after they have been scraped bright and then dipping them into a pot of melted solder. A film of solder will immediately attach itself to the parts. This process is called "tinning." If the two parts which are to be united are then twisted or held together and placed in the flame of a blow torch until

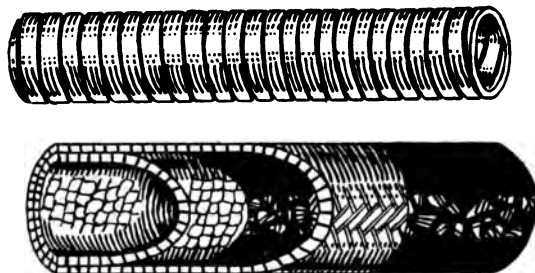

FIG. 329.—Flexible conduits for electric wiring.

the film of solder is melted and then allowed to cool without disturbance, a perfect joint will result.

The wiring on automobiles is often protected from mechanical injury by enclosing it in metallic or fabric tubing called "conduit." Figure 329 shows two kinds of conduit in common use for this purpose. The upper figure shows a section of flexible metal tubing made of metallic strips wound spirally around a mandrel. The strips are so interlinked that after the mandrel is removed there remains a continuous flexible metal tubing that may be bent easily around short corners. This is excellent for protecting the electrical conductors from injury. The lower figure shows a section of "circular loom" made up of two layers of heavy cotton tubing impregnated with a frictioning material. This forms an effective and low-priced protection for the wiring.

**141: Wiring the High-tension System.**—The wire used in the high-tension system may be of any of the three grades shown in the upper part of Fig. 325. These cables afford ample insulation for the high secondary voltages. They should be provided at the spark plug ends with good copper terminals similar to those shown in Fig. 326. The



distributor ends are usually gripped in the terminals on the distributor unit and require no special preparation. The high-tension cables are well protected from mechanical injury by being enclosed in metal conduit for the greater portion of their length. This protection is necessary because of the fact that any injury to the insulation on the cable would permit the high-tension current to escape at the point of injury and thus cause a missing cylinder on the engine. Oil is very detrimental to the rubber insulation, causing it to soften and lose its insulating properties. For this reason, the wiring of the ignition system should be protected from oil. Any oil inadvertently spilled on the wiring should be wiped off immediately.

**142. Testing High-tension Insulation.**—A high-tension cable which is suspected of having weak insulation may be tested by the method shown in Fig. 330. A single vibrating coil is connected to a suitable battery. The cable under test is connected to one of the secondary terminals on the coil. A metal ring just large enough to encircle the

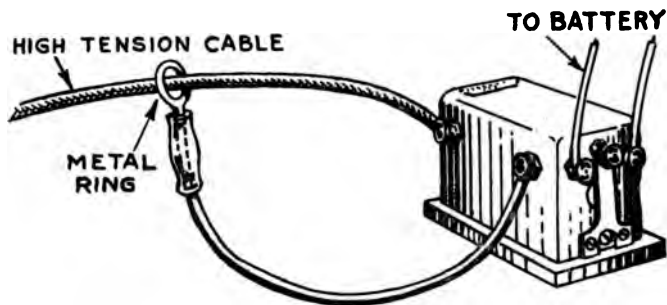

FIG. 330.—Testing the insulation of high-tension cables.

cable snugly is fitted in one end of an insulating handle. A wire running through the handle makes contact with the ring and with the other secondary terminal on the coil. When the primary circuit is closed, the vibrating coil will impress a series of high-tension current surges upon the cable. With the coil in action, the ring is moved slowly along the cable. Any weak spot in the insulation of the suspected cable will permit a spark to jump from the ring through the punctured insulation to the conductor at the center of the cable. This spark causes a series of sharp snappy sounds. If no such sounds are heard, the cable may be safely used.

**143. Care of the Distributor.**—The distributor handles the high-tension current generated in the secondary winding of the coil. Its function is to receive this high-tension current from the coil and direct it to the proper spark plugs in the regular firing order of the engine. In some units, this distribution is accomplished by a rotating arm carrying a carbon brush. This carbon brush presses on the vulcanized rubber

cap of the distributor, as the arm rotates, and makes contact with the distributor segments. The friction between the brush and its track causes a certain amount of carbon to wear off as dust. If this dust is allowed to collect, it will interfere with the proper operation of the distributor by causing short circuits from one segment to another. For this reason, the distributor cap should be wiped out occasionally to remove this dust. Oil in large quantities is a detriment in the distributor because it holds the carbon dust, thus aggravating the trouble. However, a very slight amount of vaseline applied to the distributor brush track will lessen the friction and reduce the quantity of carbon dust. The track should be rubbed over with a rag dampened with vaseline, and then wiped with a dry cloth. The imperceptible film of oil left by this process is enough to provide the proper amount of lubrication without retaining the dust worn from the brush.

In another form of distributor the rotating arm does not make actual contact with the distributor segments, but the arm ends in a metallic segment which passes very close to, but does not touch, the segment attached to the spark plug leads. The surge of high-tension current is forced to jump the short air gap between the two parts. After considerable service, this arc will have partly burned away the metal parts at the gap, causing the gap to widen. New segments should be applied before the gap becomes so wide that the spark will no longer jump across.

Moisture will interfere with the operation of a distributor; therefore, it is advisable to keep water away from this unit. In washing the car, water is sometimes splashed through the radiator and hood upon the electrical equipment. This should be carefully wiped away before attempting to start the engine.

**144. Installation and Care of Spark Plugs.**—The spark plugs should be carefully screwed in place in the cylinder. Just sufficient effort should be used on the wrench to set them firm enough to prevent leakage. If any additional pressure is used, it will be difficult to remove the plug and damage may possibly result. The  $\frac{7}{8}$ -in. plug uses a copper-asbestos gasket to provide an air-tight fit between the plug and the cylinder. This gasket should be renewed when it becomes much flattened. With a  $\frac{1}{2}$ -in. plug the tightening of the joint depends upon the taper of the standard pipe thread used.

The combustion of the fuel mixture in the presence of lubricating oil in the cylinders of the engine leaves a deposit of carbon on the plug. This carbon will often render the plug inactive by providing a short circuit between the firing points. It may be removed from the plug by scraping with a penknife or a wire brush. Gasoline is also useful for this purpose.

The points of the plug should be adjusted to give a spark gap of

about .030 in. A thickness gage gives a ready means of making this adjustment correctly. In the absence of such a gage, a thin dime may be used as an approximation. A wider setting than this distance will cause the engine to miss at slow speeds under heavy load, due to the possibility of the spark's not jumping the wide gap through the highly compressed gas. This action is especially noticeable on magneto ignition as the spark produced by the magneto at low speed is liable to be weak. If the gap is extremely narrow, the engine may miss when running slowly under a light load as the length of spark may not be sufficient to generate heat enough to ignite the thin mixture then present in the cylinder.

The variations of heat to which the porcelain insulator is subjected sometimes causes it to crack. A cracked porcelain should be replaced since the current will follow the path of least resistance through the crack rather than jump the gap between the points in the highly compressed charge in the cylinder.

**145. Spark Plug Testing.**—The porcelain of a spark plug may become

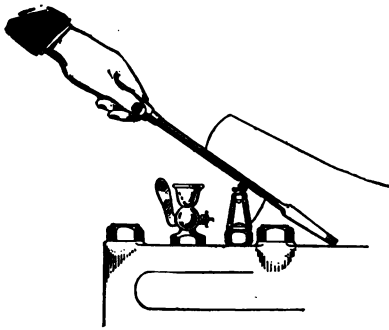

Fig. 331.—Method of locating a misfiring cylinder.

cracked, due to the intense heat of the engine or to an accident. The plug is then usually short circuited through the crack in the porcelain; consequently, no spark is produced in the cylinder. A broken porcelain may sometimes be detected by a grating sound when an effort is made to wiggle the porcelain of the plug with the fingers before the plug is removed from the cylinder. The plug may also become short circuited through carbon or oil deposits between the plug points.

The spark plug which seems to spark properly, when tried out on the cylinder block in the open air, may fail entirely inside the cylinder because of the increased resistance offered to the passage of the spark across the gap under the high compression in the cylinder. For this reason, the most satisfactory way to test a plug is to test it under actual operating conditions. To determine which cylinder is missing fire, the plugs may be short circuited, one or more at a time, with the engine running, by holding a screwdriver or hammer head from the plug terminal to the cylinder head, as shown in Fig. 331, or the wires may be removed from the spark plug, one or more at a time, and the change in the engine power noted. If the plug under test has not been operating, there will be no change in the engine power, but if the engine shows a material loss of power, it may be safely concluded that the plug has *been operating* satisfactorily. The priming cups may be opened one at

a time and the issuing flame watched. A hot flame should issue with each explosion of the cylinder.

A sooty, oily appearance of the spark plug points, when removed from the cylinder, also indicates that the plug has not been working properly. A white, or yellowish white, clean, dry appearance of the porcelain indicates that the cylinder has been firing. Probably the most satisfactory method of testing a spark plug is to exchange plugs

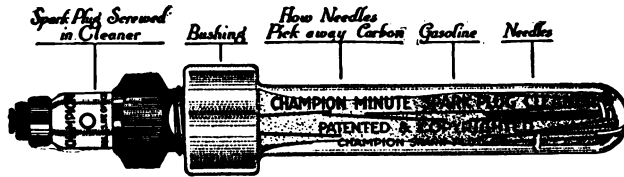

FIG. 332.—Champion spark plug cleaner.

between the cylinders or to try out a plug which is known to be good, in the cylinder which is misfiring.

If the plug is not to be taken apart, it can be cleaned with a brush and gasoline. If it is taken apart, the porcelain may be cleaned without scratching by using water and a little road dust. Emery cloth should not be used as it will scratch the porcelain. Figure 332 shows the Champion spark plug cleaner which screws onto the plug. The container is filled with gasoline and upon being shaken, the needles, in combination with the gasoline, remove any carbon deposit that may be on the plug.

**146. Ignition Coil Testing.**—The ignition coil can be examined only from the outside. Most manufacturers seal the coil by impregnating the windings, etc. with a hard wax or pitch composition. This holds the parts in the proper place and also provides the thorough insulation which the coil requires. The condition of the different parts of the coil can be determined by tests made from the outside of the coil.

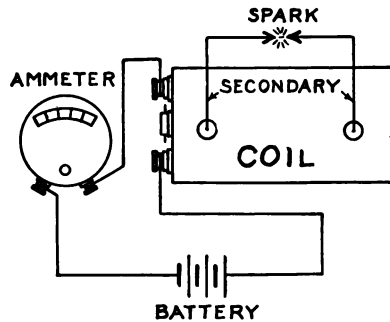

FIG. 333.—Testing vibrating ignition coil.

**Vibrating Coils.**—Vibrating ignition coils may be tested by the method shown in Fig. 333. A special low reading ammeter whose scale is graduated from 0 to 3 amperes is connected in series with the primary winding and vibrator of the coil and a 6-volt battery, either storage or dry cells. Leads which terminate in a 1/4-in. spark gap are provided from the secondary terminals of the coil. When the circuit is completed through the primary winding, the vibrator should vibrate freely, giving off a continuous and rather high-pitched tone. The current flow, as indicated by the

ammeter, may be regulated by adjusting the vibrator to from  $\frac{3}{4}$  to  $1\frac{1}{2}$  amperes. There should then be a continuous flow of heavy blue sparks at the spark gap. Thin, yellow sparks indicate a poorly adjusted or weak coil. The adjustment should be varied until the spark has considerable volume. When the spark is blown upon, it should spread and bend away from the points in the direction of the air current. If it breaks and becomes irregular, the vibrator is not properly adjusted.

If the vibrator operates properly and there is no spark at the spark gap, the secondary circuit is probably open inside the coil. Poor insulation will permit the secondary current to jump across the defective insulation within the coil instead of making its appearance at the spark gap. This condition is frequently indicated by a buzzing noise accompanied by smoke issuing from the interior of the coil, and can be remedied only at an electrical service station. The coil is usually returned to the maker for repair.

An excessive reading of the ammeter indicates a short circuit in the primary winding, or that the vibrator points are stuck together. If, after examining the points and dressing them smooth, the high reading continues, it may be safely assumed that the primary winding is at fault. The coil should then be sent to the manufacturer for correction. A poor connection will cause the ammeter needle to jump about instead of remaining steady.

When the coil is operating properly, a faint yellow spark will appear at the vibrator points. Should this spark become blue in color and larger in volume, emitting a snappy sound, the condenser within the coil is probably not functioning, either because the insulation between the leaves of the condenser has been punctured and the condenser short circuited or because the condenser circuit is open. The result will be evidenced in rapidly pitting vibrator points, requiring their renewal at frequent intervals. A defective condenser must be replaced by the maker of the coil.

A light tension on the vibrator spring means economy of current, but if the tension is too light the engine will not run evenly. On the other hand, a heavy tension on the vibrator points means an excessive current consumption by the coil, resulting in pitting of the points due to the incapacity of the condenser to absorb the increased amount of energy stored in the magnetic field.

*Non-vibrating Coils.*—Non-vibrating coils are very simple in their make-up, containing only a magnetic core and primary and secondary windings. On some coils the condenser, and the safety spark gap are also included in the assembly, but often either one or both of these are contained in other parts of the ignition system.

A test of the proper working of the coil may be made by attaching one end of a piece of wire to the metal part of the engine and by bringing the

other end to within  $\frac{1}{4}$  in. of the secondary terminal of the coil. The breaker points in the interrupter are then opened and closed. If a good snappy spark jumps the gap from the secondary terminal to the end of the grounded wire every time the points are separated, the coil is in perfect condition and whatever trouble is present may be looked for in the other parts of the ignition system. A failure of the spark to appear may be the result of any one of the conditions mentioned in the following paragraphs.

Moisture in the safety spark gap may lower its resistance so that the spark will occur at this point. The safety spark gap should be dried carefully to eliminate all traces of moisture.

A defective condenser will not absorb the hang-over current produced by the self-induction of the primary winding. This will prolong the collapse of the magnetic field to such an extent that the required voltage will not be built up in the secondary winding. Excessive sparking at the interrupter, points to this condition. If the condenser is mounted so that it can be removed, as in the case of the Atwater-Kent closed circuit system, it may be taken out and tested by the method described in Section 147. If the condenser is contained within the coil, the entire unit must be returned to the manufacturer.

**147. Condenser Troubles and Method of Testing.**—The condenser is connected in parallel with the vibrator points in vibrating coil ignition systems and in parallel with the breaker points in non-vibrating coil systems. Its purpose is to absorb the after-current generated by the self-inductive action of the primary winding and to prevent this current from making its appearance at the contact points in the form of an arc or spark. The absorption of this current also causes a quicker collapse of the magnetic field, causing the secondary to build up a current surge of a much higher voltage than when the condenser is not present or is not working properly. The proper action of the condenser has an important effect on the quality of the spark produced. An ignition system that will give a hot fat spark with the condenser operating properly will give but a feeble spark when the condenser is removed or is in poor condition.

The troubles liable to be found in a condenser are two in number. The insulation between the tinfoil layers in the condenser may be punctured, allowing the two sides to make electrical contact with each other, in which case the condenser is said to be *shorted*; or the connections to the condenser may be broken.

In the first case, the current will flow through the condenser without hindrance. The primary current will not be interrupted, when the contact points are opened, and no spark will be produced in the cylinder. In the second case, the condenser is not permitted to absorb the self-induced current in the primary circuit and a weak spark is produced in the cylinder.

The probable condition of the condenser is determined by a simple test made as follows: The interrupter points are opened and closed and the quality of the spark produced at a gap of about  $\frac{1}{4}$  in. in the secondary circuit noted. If the spark is vigorous and there is not excessive sparking at the contact points, when they are opened, the condenser is functioning properly. If there is considerable spark at the contact points and the spark produced at the gap is feeble, there is probably a loose connection or an open circuit in the condenser circuit. If no spark is produced at the gap and no spark occurs at the contact points, upon separation, while at the same time the ammeter shows the usual current to be flowing, the insulation in the condenser has been destroyed or the condenser shorted in some manner.

If the condenser is placed in such a position that it can be removed from the other parts of the ignition system, it can be tested in the manner shown in Fig. 334. A 110-volt direct-current service is used. A

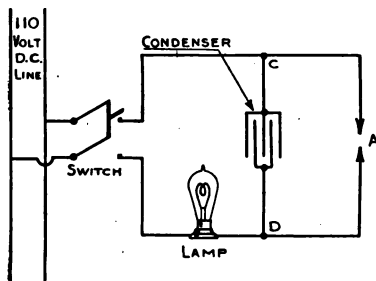

FIG. 334.—Connections for testing condenser.

60-watt lamp is connected, as shown in the diagram, in series with the condenser, and the two contact points *A* are so arranged that when they are brought together the condenser is short circuited. With the contacts points *A* separated and the switch closed, the lamp will be dark if the condenser is in good condition. Upon bringing the points *A* together, a snappy spark will occur at this point and the lamp will

light up as long as the points are in contact. When the points are again separated, the lamp will go out. When the switch is opened and the contacts brought together, a heavy spark will result from the charge stored in the condenser. If the lamp burns with the switch closed and the points *A* apart, the condenser is shorted because of defective insulation. If the lamp remains dark under these conditions and still no spark is given at the points when they are brought together after the switch has been opened, the condenser is in open circuit—there is a poor connection or a break in the wires leading to the condenser.

Defective condensers are not easily repaired on account of their delicate construction and also because of the fact that they are often sealed within the coils. The most economical method of curing a defective condenser is to send it back to the maker for replacement.

A condenser sealed within the spark coil of a battery ignition system, or contained in the armature of a magneto, is often difficult to test because of the fact that it is often paralleled by other parts of the circuit. By examining the wiring diagram, it is possible to determine whether the condenser can be isolated between two terminals of the

coil. If so, the test outlined can be made. In Fig. 335 is shown the Remy two primary terminal coil with the terminals between which the condenser is located. All that is necessary is to connect these two terminals into the circuit shown in Fig. 334 at the points C and D. Figure 336 shows the two terminals used for testing the condenser in the Delco coil, and Fig. 337 shows the two terminals used for testing the condenser in the Connecticut coil. In each of these cases it will be noted that the condenser is the only part of the coil included between the terminals indicated.

**148. Recharging Magnets.**—The magnets used on magnetos to provide the magnetic field are called *permanent* in the sense that they will retain their magnetism for a considerable length of time. They will, however, gradually lose their magnetic strength, and after an extended period of use will have to be recharged. This is especially true if the magneto has been subjected to rough handling, or if the magnets have been removed from the magneto and subjected to jars and mechanical shocks while separated from the rest of the magneto.

A fully charged magnet, such as is used on magnetos, should be able to lift a piece of steel weighing from 12 lb. to 14 lb. If the spark produced by the magneto is weak and it is

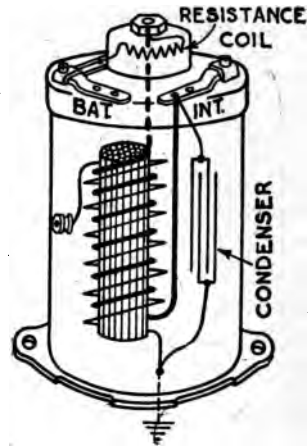

FIG. 335.—Condenser connections in Remy two-terminal coil. Test condenser between Int. terminal and base of coil.

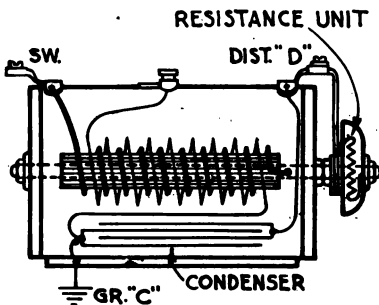

FIG. 336.—Condenser connections in Delco coil. Test condenser between Dist. terminal and base of coil.

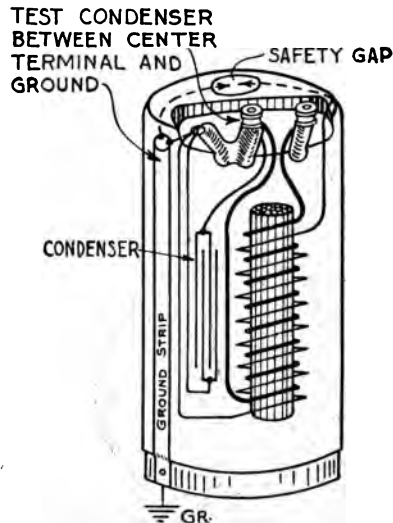

FIG. 337.—Condenser connections in Connecticut coil.

suspected that the magnets have lost their strength, they should be removed from the instrument and tested. If they will not lift the required



weight, they should be recharged. After a magnet has been removed from a magneto, it should be handled as little as possible. A piece of soft iron or steel, called a keeper, should be placed across the ends as shown in Fig. 338. This keeper provides a path for the magnetic lines of force of the magnet and helps to conserve its strength. It should be in place at all times except when other operations necessitate its removal.

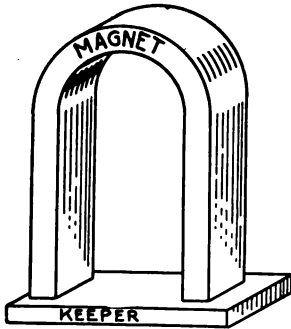

FIG. 338.—Magnet with keeper attached.

The poles of the magnets are sometimes marked N and S to distinguish the north and south poles, respectively. The magnetic lines of force leave the magnet by the North pole and enter by the South pole. The polarity of the magnet can be determined, if the poles are not marked, or the marking checked, by the method shown in Fig. 339. A small pocket compass is brought near the poles of the magnet; the end of the compass needle that points to the north will point to the South pole of the magnet, and vice versa. It is well to check the marking on the mag-

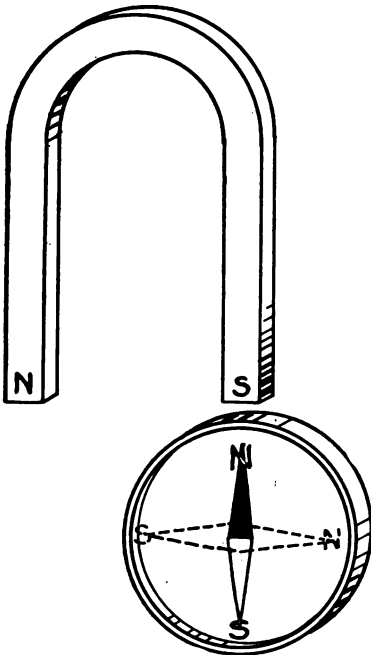

FIG. 339.—Determining polarity of a magnet.

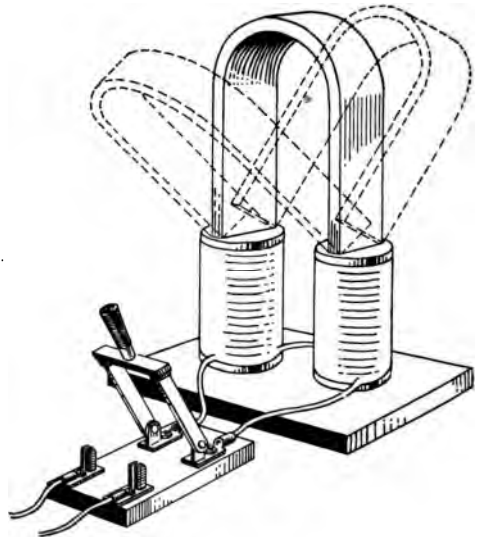

FIG. 340.—Magnet recharger.

net, if there is any, to see if the magnetism has been reversed by a previous recharging.

To recharge a magnet it is only necessary to bring it into a strong

magnetic field for a short time. This field is usually provided by a large electromagnet similar to the one shown in Fig. 340. This shows the electromagnet connected to a source of current of the proper voltage. Most electromagnets of this nature are wound for use on a 110-volt circuit, and are connected directly to a direct-current line. The electromagnet has two poles. Its polarity can be determined by testing with a pocket compass. When this has been determined, its poles should be marked with pencil or chalk. The magnet to be charged should then be placed on the electromagnet with its North pole on the South pole of the electromagnet, and its South pole on the North pole as shown in Fig. 340. Current should then be turned into the windings of the electromagnet for a few seconds, meanwhile rocking the magnet back and forth on the electromagnet or jarring the magnet by several light blows from a mallet. The object of the rocking and the blows is to enable the molecules of the magnet to arrange themselves so as to give the greatest magnetic strength. A very short time is required to remagnetize the magnet. The current should be turned off in about  $\frac{1}{2}$  minute. The magnet should be removed from the electromagnet and its lifting power tested. If satisfactory, the keeper should be placed on the poles of the magnet and the magnet returned to the magneto as quickly as possible. Care should be taken to charge all magnets of a set to the same strength. They also should be of the same quality of steel.



FIG. 341.—Keeper on magnet in Aero magneto.

Figure 341 shows the Aero magneto with a keeper placed across the poles of the magnet. This keeper should be placed in position while the magnet is still in the magneto. The makers of this instrument recommend this practice in order to protect the magnet as much as possible. Figure 342 shows the magnet recharger furnished by the manufacturers of this magneto to their service stations for recharging the magnets of their magnetos. A master magnet is kept in the coils of this recharger at all times. The magnet to be recharged is attached to the master magnet and is then pushed forward so that it is within the coils. The switch is then closed, permitting the current to flow for a few seconds. It is then opened and the magnet pulled forward and the keeper placed across the ends of the magnet. The magnet is then removed from the recharger and placed in position on the magneto with the keeper still in place. When the magnet is again in place in the magneto, the keeper is lifted off.

Apparatus for recharging magnets need not be so complete or so elaborate as the methods just described. The magnet may be recharged by the method shown in Fig. 343 from a 110-volt D. C. line. The polarity of the magnet is first determined with the aid of a small compass, while the polarity of the line is determined by the method de-



FIG. 342.—Recharger for Aero magneto.

scribed in Chapter I. A lamp bank containing thirty 32-candlepower carbon filament incandescent lamps is connected to one side of the line and a length of insulated wire similar to that used in No. 16 lamp cord is wrapped around the legs of the magnet until no more can be added. The direction of winding the wire on the magnet must be given special

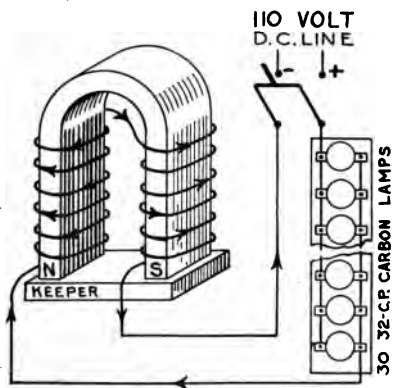

FIG. 343.—Simple method of recharging magnet.

attention. The magnet is taken in the right hand with the thumb extending in the direction of the lines of force from the magnet (out of the North pole and in at the South pole). The wire should be wound around the magnet so that the current will flow through the winding and around the magnet in the direction in which the fingers encircle it. These directions have been carried out in Fig. 343. A careful study of this illustration will make the method clear. The current is permitted to flow for a few seconds and the magnet is then recharged.

*Recharging the Magnets on the Ford Magneto.*—The magnets on the Ford magneto may be recharged in the manner just described, but their removal is so difficult that they are usually recharged in place on the flywheel. The method sometimes adopted for this purpose is shown in Fig. 344. Before this method is used, the magneto must be carefully

placed in the proper position. This is done by holding a small compass 1 in. to the left and 6 in. to the rear of the magneto terminal. The engine is then slowly cranked until the needle on the compass points straight to-

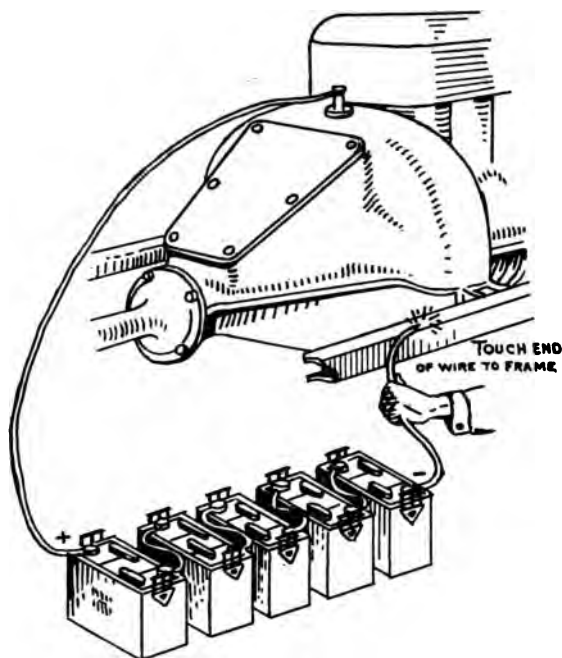

FIG. 344.—Recharging magnets of Ford magneto.

ward the front of the car as shown in Fig. 345. Five 6-volt storage batteries connected in series are used as a source of current. The positive

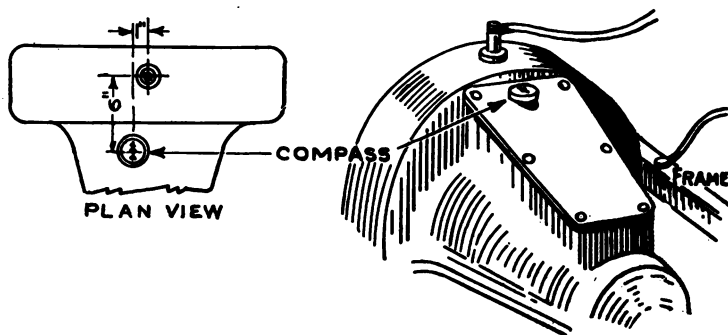

FIG. 345.—Setting Ford magneto for recharging magnets.

terminal of the set is connected to the magneto terminal after disconnecting the lead running to the ignition and lighting systems. The other end of the set of batteries has a lead attached with which the frame or

metal work of the car is touched two or three times for about a second at a time. The arc which forms, when the connection is broken, should be pulled out slowly. The coils of the magneto act in the same way as the windings of an electromagnet and build up the strength of the magnets. With this arrangement about 48 amperes of current are permitted to pass through the magneto coils on the older Ford models and about 56 amperes on the later models. The results produced by this method are often not satisfactory and the method should not be used except by one familiar with the handling of electrical equipment.

A satisfactory method of charging the Ford magnets while still in the car is to use a special magnetizer made for this purpose which can be applied to the magnets through the opening for the gear case cover. This magnetizer can be had to operate on current from a six-volt storage battery or from 110 volt D. C. lines.

## CHAPTER X

### IGNITION TROUBLES AND REMEDIES

**149. Starting the Engine.**—The modern automobile engine is set in motion by an electric starting motor. This motor takes the place of the old method of cranking the engine by hand and thus removes one of the inconveniences of the early day automobile. Before the engine is started, the ignition switch is turned "ON," the spark advance lever placed in the fully retarded position, the throttle lever set in the partly open position, and the carburetor "choked" by the carburetor control button on the dash. The starting switch is then pushed down with a firm unhesitating movement of the foot as far as it will go. This permits the starting current to flow through the electric motor which rotates the crankshaft of the engine. If everything is in proper order, the engine will start in from one-half to two seconds. In cold weather, however, it may require from five to ten seconds. After the engine is running on its own power, the spark should be advanced and the carburetor choke button gradually pushed in as the engine warms up.

**150. Failure of the Engine to Start.**—If the engine does not start within the time mentioned, something is wrong and the foot should be removed from the starting switch. It would be useless to subject the storage battery to the unnecessary heavy drain caused by cranking the engine for a long period. The engine should be inspected carefully to determine whether the carburetor is getting gasoline and whether a spark is actually taking place at the spark plugs at the proper time. Faults in the ignition system should be set right. If fuel is coming to the carburetor and still the engine will not start, it may be because the engine is cold and the gasoline does not evaporate readily. Heat applied to the carburetor or to the inlet manifold will help to vaporize the fuel.

**151. Testing the Battery Ignition System.**—In the battery ignition system the source of current is the battery, either dry or storage cells. These are the first things to be examined in the event of a failure of the ignition system. The induction coil is next in importance and should be tested in the manner described in Chapter IX, providing the battery is in good condition. The interrupter or timer and the distributor are to be inspected next and if found in good condition, the condenser should be inspected very carefully. A defective condenser will cause a great deal of trouble in the ignition system, and in the event of damage should be repaired or replaced. A condenser operating properly will increase

the effectiveness of the spark produced in the cylinder about twenty-five times more than the spark produced by an ignition system in which the condenser is defective. The resistance unit should also be given some attention to guard against its burning out.

**152. Testing the Magneto Ignition System.**—The magneto ignition system contains the same elements as the battery system with the exception that in the magneto the current is generated within the instrument itself by electromagnetic induction instead of being supplied by an external battery. The magneto ignition system contains no resistance unit. The volume of the current depends upon the speed of rotation of the armature of the magneto and upon the strength of its magnets. Weak magnets will not provide sufficient magnetic lines of force to generate the required current. If, in testing the magneto ignition system, the parts mentioned in the previous paragraph are found to be in good condition, the magnets have lost their strength. They should be recharged to their original strength.

**153. Locating a Misfiring Cylinder.**—Misfiring or “missing” of the engine may be caused by faulty ignition, by a faulty carburetor, or by the valves operating improperly. Missing which occurs with some regularity may usually be attributed to faulty ignition or valve operation. Very irregular missing is usually caused by a faulty carburetor, but it may result from dirty breaker points or some other fault in the ignition system.

To detect and correct faulty ignition, the cylinder at fault must first be located. This may easily be done with the engine running by short circuiting the spark plug or bridging between the engine cylinder and spark plug terminal with either a hammer head or a wooden handled screwdriver as shown in Fig. 331. If, in testing the various spark plugs, one is found which, when short circuited, does not affect the operation of the engine, it is in all probability the one at fault. The trouble may be either in the ignition apparatus or in the spark plug itself.

Another convenient method of locating a misfiring cylinder on engines having vibrating coil ignition, such as the Ford, is to run the engine first on one cylinder and then on another by holding down all of the vibrators except the one connected to the cylinder under test. The engine should run idle on any one of the cylinders and should show approximately the same power from each.

**154. Defective Spark Plugs.**—The most common fault found in the spark plug is carbonizing or sooting, which results in short circuiting the high-tension current so that, instead of jumping between the points or electrodes of the plugs in the combustion chamber, it passes through the carbon accumulation directly to the metallic shell. The plug should be removed, and, if there is evidence that it is short circuited, the carbon accumulation should be removed. This may be done by first scraping off

the carbon and then washing the plug with gasoline and a stiff brush. By inspecting the plug carefully, it can be determined whether or not the porcelain has become cracked or damaged in any way, and also whether the gap or distance between the electrodes is correct. This gap should be between .025 to .030 ( $\frac{1}{40}$  to  $\frac{1}{32}$ ) in., about 3 thicknesses of an ordinary U. S. post card. If this gap is found incorrect, the electrode that is attached to the shell may be bent until proper adjustment is secured. A worn dime is an approximate gage to use for setting this gap.

The porcelain of the plug may be cracked in such a manner that it will not show upon casual inspection, but it may be detected as follows: If the plug is screwed into the cylinder and some pressure is brought to bear against the upper part of the plug with the finger, grating or grinding will sometimes be heard and a very small motion will be felt. The high-tension current will often bridge the gap between the center electrode and the shell through a crack in the porcelain, instead of jumping across the space intervening between the electrodes or points of the plug. The spark plug may be tested by removing it from the cylinder and laying it on the cylinder block. The engine should be turned over by hand and observations made as to whether a spark jumps between the electrodes. The plug should, of course, be laid on the cylinder block so that no part of the plug, except the shell, will touch the cylinder block. This, however, is not a positive test, since the spark may sometimes jump the gap between the points of the plug and yet be at fault, owing to the fact that under compression the resistance is greatly increased between the plug electrodes. The spark may jump this gap in the open air and yet not pass under the conditions of operation in the cylinder.

A positive test for the plug is to replace it with one that is known to be perfect. If the condition is improved, the original plug is unquestionably at fault.

**155. Defective Wiring and Ignition Apparatus.**—If the plugs are found in good order, and yet one or more cylinders continue to misfire, the trouble may be due to a lack of secondary current in the wire connected to the plug. The trouble can be located when the engine is running, or being cranked, by detaching the wire from the plug and holding the end about  $\frac{1}{8}$  in. to  $\frac{1}{4}$  in. from the plug binding terminal or cylinder head. If the secondary current is being distributed properly to the cylinder in question, a spark will occur at the gap. If there is no spark across the gap and there is regular sparking at the other plugs, the trouble is undoubtedly due to defective high-tension wiring, cracked distributor head, or poor timer contact.

If the rubber covering or insulation on the spark plug wires is chafed or cut through, allowing the conductor to touch or nearly touch any metal part of the car, the current will be short circuited and will not jump the gap in the plugs. It is not necessary that this insulation be



worn down to the metal of the conductor. If a sharp snapping is heard, when the engine is running under a heavy pull, it is evidence of a short circuit from the high-tension conductor to the metal work. The fault will usually be found due to imperfect insulation of the spark plug wires, or a wire loose from the spark plug terminal. The only satisfactory remedy for worn insulation is to replace the wiring with new.

Irregular misfiring of all cylinders may be due to defective primary wiring, discharged battery or weak magneto, corroded or loose battery connections, improper adjustment of vibrator or interrupter contact points, or defective condenser.

**156. Battery Ignition Breaker.**—A common cause of irregular misfiring, when ignition is from a battery high-tension distributor unit, is an improper make-and-break of the primary circuit by the contact points. In a majority of the various systems employed, the contact points are made of tungsten and normally held closed by spring tension, the spark occurring the instant the primary circuit is broken by the cam lobe's bearing against the contact arm. The contact points have a standard opening of .020 in., or about the thickness of two U. S. post cards. If found dirty or uneven and pitted, they should be cleaned by passing between them a fine flat file, or preferably a piece of No. 00 sandpaper.

**157. Defective Condenser.**—A defective condenser is indicated by serious sparking and rapid burning of the interrupter or vibrator contact points also by the inability of the coil to produce a hot secondary spark when the primary circuit is interrupted. If these conditions exist, the condenser is probably either punctured (insulation between tinfoil layers destroyed) or open circuited. A positive test and remedy will be to replace the condenser or unit in which it is contained with another that is known to be good. If the condenser is mounted inside the coil, the entire coil usually must be replaced. When it is mounted in the breaker housing, it can usually be replaced without disturbing the other parts of the system. The action of a good condenser results in intensifying the secondary current nearly twenty-five times and preventing an arc at the breaker points when they are separated.

**158. The Resistance Unit.**—In many battery ignition systems a resistance unit is placed in the primary circuit to protect the coil and battery in case the ignition switch is left on, and to aid in equalizing the intensity of the secondary spark at high and low engine speeds. In case this resistance unit should be burned out or for any other reason become open circuited, the primary circuit will be opened and no current can be obtained at any of the plugs. This resistance unit consists of a small coil of resistance wire and is usually placed either on the coil or on the breaker housing. In case this resistance unit should be burned out or accidentally broken, the terminals may be temporarily short circuited with a piece of wire to relieve an emergency, but in all such cases the resistance unit

*must be replaced with another of the same kind as soon as possible.* Continued operation without it will result in serious burning of the interrupter points and may cause injury to the coil and condenser.

**159. Coil Adjustments.**—A frequent cause of no current at the plug is due to coil trouble, especially where a vibrating coil is used for each cylinder. When the vibrator points become pitted, out of line, or burned, good contact is impossible. The tension on the vibrator spring may also become changed, permitting the coil to consume too much or too little current.

In the case of burned or pitted points, they should be filed flat with a thin smooth file, or preferably a piece of No. 00 sandpaper should be passed between them. In either case, the points should be shaped so as to meet each other squarely.

If it becomes necessary to adjust the tension on the vibrators, the tension should be entirely taken off and gradually increased until the engine runs satisfactorily under all load conditions with the coil consuming as little current as possible. It is very important to have all the units adjusted alike. This can be done easily after a little experience. The most accurate method of coil adjustment is with a coil current indicator by which the amount of current consumed is measured. Coils are built to consume about  $\frac{1}{2}$  to  $1\frac{1}{2}$  amp. when the system is operating properly; consequently, the tension should be adjusted so that the current consumption of each coil is not much greater than this amount.

**160. Breakdown of Coil Wiring or Insulation.**—If no current is obtained in the secondary circuit of a coil, when the vibrator is working as it should, the trouble is probably due to either a broken wire or punctured insulation inside of the coil. It sometimes happens that the binding post wires become loose from the post just inside of the coil. If only a slight spark can be obtained, the insulation on the inside wire may be broken down, thus causing a short circuit of the current. Obviously, there is no remedy but to replace the coil. Moisture in the coil may also cause it to become short circuited. In this event, the coil should be dried out thoroughly before it is put back into service.

**161. Timers.**—Trouble in the timer is usually due to oil, water, or dirt which has gotten into the housing, causing either a short circuit or poor contact. This foreign matter should be cleaned out in order to permit good service. After a time, the contact segments become worn and irregular, causing misfiring at high speed. In this event, it will be necessary to supply a new timer.

**162. Improper Spark Timing.**—If the engine kicks back, when being cranked, the spark is too far advanced and should be retarded so that it will not occur until the piston has passed the dead center. The tendency of an early spark on starting is to cause the engine to start backward. Too early a spark at low speeds will make the engine knock and will cause the car to jerk.

A retarded spark causes the engine to overheat and lose considerable of its power. There is no advantage in retarding the spark past center, even in starting. When the engine is running, the spark should be advanced in proportion to the speed. With the spark control lever fully retarded, the interrupter points should be timed to open (thus causing the spark) when the respective pistons have just left the upper dead center at the end of their compression strokes.

On cars equipped with automatic spark advance, the troubles due to early and late spark are seldom experienced, providing the original timing of the spark was correctly made. Preignition from other causes, however, may occur with either type of spark advance.

**163. Dry Batteries.**—Weak or exhausted batteries are a common source of trouble. If the batteries are suspected, they should be tested with a small ammeter. If any one of the dry cells shows less than 8 amp., it should be taken out and replaced with a new one. One weak cell will interfere greatly with the operation of the others in the set. Occasionally, a weak dry cell can be livened up temporarily by boring a small hole through the top and pouring in a small quantity of water, or better still, vinegar. The effect, however, is only temporary.

A dry battery should always be kept perfectly dry. If it becomes wet on the outside, there is a tendency for it to be short circuited and exhaust itself. This is true especially if water is spilled on the top of the battery between the terminals.

**164. Storage Batteries.**—If the storage battery appears dead, or shows lack of energy, it may be due to one of the following causes: (a) discharged; (b) electrolyte in the jars too low; (c) specific gravity of electrolyte too low; (d) plates sulphated; (e) corroded terminals; (f) battery terminal broken loose from the plates; or (g) broken down insulation. These troubles are fully treated in Chapter II.

If the same battery is used for starting and also for ignition and if it has very little charge, it may not be strong enough to produce a spark at the same time that the starting motor is drawing current to turn the engine over. In this case the engine will generally start when cranked by hand.

**165. Magneto Troubles.**—If the ignition trouble has been located in the magneto side of the ignition system and the plugs and wiring system have been found in good working order, attention should be turned to the magneto itself. The distributor plate should be thoroughly cleaned with a cloth moistened with gasoline, to remove any foreign matter such as oil and carbon dust which may have collected after considerable use. After attending to this, it should be determined whether or not the magneto is generating current. This can be done by disconnecting the magneto ground wire, after which either the magneto spark plug cables may be disconnected or the distributor block removed. A spark

gap is provided by resting a screwdriver on the magneto frame, holding the point of it  $\frac{1}{8}$  in. to  $\frac{1}{4}$  in. from either the collector ring or slip ring brush terminal. If no spark appears across this gap, the trouble is in the magneto itself.

The contact points may be pitted or burned or may not have the proper adjustment. The correct opening of the magneto interrupter points is from .012 to .020 (approximately  $\frac{1}{64}$ ) in. If they are set too close, excessive arcing will occur and the points will burn and cause weak spark at high speeds. If they are set too wide, the result will be burning of the points and weak or no spark at high engine speeds, in which case the primary winding does not have time to "build up," thus decreasing the strength of the spark. If the interrupter points are found dirty or badly pitted and uneven, they may be cleaned by passing a thin flat file or a piece of No. 00 sandpaper between them. *The contacts should not be filed unless absolutely necessary.*

The carbon or collector brushes may be dirty or worn. They should be cleaned, or, if badly worn, replaced with new brushes, making sure that each brush has the proper spring tension.

It happens occasionally that the magnets become weak or demagnetized or they may be placed on the magneto in the wrong position. If weak or demagnetized, they should be remagnetized before being replaced. Care should be exercised in getting the like poles of the magnets on the same side of the magneto. Most magnets are marked with an N, indicating the North pole.

**166. Premature Ignition.**—Premature ignition or *preignition* is caused by particles of carbon, sharp corners, etc. in the combustion chamber becoming incandescent from the heat of explosion and igniting the charge on the compression stroke before the spark occurs. Preignition occurs generally when the engine is laboring under a heavy load at slow speed, such as when going up a steep hill on high gear. Any engine will have premature ignition if it becomes excessively hot under low speed and heavy load, but the tendency to preignite is much more marked if the cylinder is full of carbon deposits. These carbon deposits should be cleaned out as explained before. Preignition may also be due to improper spark plug installation, such as using a plug which extends too far into the cylinder head and which is not properly cooled.

**167. Effects of Faulty Ignition on Engine Operation.**—Any one of the faults mentioned will produce serious irregularities in the operation of the engine. Complete failure of the ignition system renders the engine inoperative. A failure of any one of the parts of the system may throw the system completely out of operation or may cause it to function irregularly. A bad spark plug will cause one cylinder of the engine to miss continually, but a bad plug is easily detected. A too wide or too narrow gap in the plug will cause the cylinder to miss at certain speeds and loads.

Defective insulation in the wires leading from the distributor to the spark plugs will cause an intermittent missing of the cylinder served by that wire. A loose connection in the primary circuit will cause missing in all the cylinders at irregular times and is apt to be very annoying, sometimes causing the engine to come to a complete stop only to start up and run as usual when started again.

A cylinder that fails to fire part of the time will give more trouble due to excessive carbon and oil than one that fires regularly. During the strokes in which no explosion takes place, the oil carried up the cylinder walls will accumulate in the combustion space. This oil will find its way to the spark plug where it will sometimes short circuit the points, thus preventing any future ignition. If the cylinder fires occasionally, the excess oil will cause much smoke and will deposit much carbon. This necessitates frequent cleaning of the spark plugs, removal of the carbon from the cylinders, and grinding of the valves.

An engine with missing cylinders will consume more fuel than one firing regularly. The charge of fuel and air drawn into the cylinder and discharged without combustion is wasted. In order to get the required amount of power from the engine, the operator opens the throttle wider, thus increasing the amount of fuel used. This causes the missing engine to be very uneconomical, resulting in high operating costs.

**168. Things to Remember Regarding Ignition.**—The proper performance of the ignition system is so important that good care and attention will result in efficient service. The following rules should be observed.

Don't blame every engine trouble on the ignition system. Remember that there are other parts which may be in poor condition.

Don't forget to turn the ignition switch "ON" before trying to start the engine.

Don't try to operate the engine on a worn-out or nearly discharged battery.

Don't permit the gap in the spark plug to burn too wide. The proper distance is .025 in. to .030 in.

Don't allow the vibrator or interrupter points to wear uneven.

Keep excess oil and water away from the ignition equipment.

Clean the distributor, once each thousand miles of driving, by wiping with a rag moistened with gasoline.

Inspect all wiring for defective insulation once each season. Replace all injured portions.

Turn the ignition switch "OFF" each time the engine is stopped.

Keep the interrupter or vibrator points adjusted to the opening recommended by the manufacturer.

Keep the safety gap dry.

*Keep the spark plugs clean.*

## INDEX

### A

- Action, storage cell, charge, 35
  - discharge, 35
- Active material, 28
- Adding water to battery, 37
- Adjustments, aero airplane magneto, 222
  - breakers and timers, 236
  - coil, 259
- Advance, spark, automatic and manual, 78
  - and retard, spark, 69
- Aero magneto, Splitdorf, 209, 214
  - airplane type, 219
  - adjustments, 222
  - wiring diagram, 221
- Aircraft engine ignition, 135
- Alternating current, 15
- Ammeter, 5, 22
- Ampere-hour, 8
- Amperes, 2
- Ampere-turn, 14
- Analogy, water, induction, 16
  - hydraulic, electric current, 1
  - hydraulic, condenser, 58
- Attraction, magnetic, 11
- Atwater-Kent system, type CC, 84
  - type K-2, 79
- Automatic spark advance, 78
  - Atwater-Kent, 83
  - Eisemann, 185
- Automatic switch, 89, 91
- Automotive ignition, requirements, 51

### B

- Bakelite, 76
- Ballast resistor, Westinghouse, 105
- Batteries, ignition, wiring, 23
  - parallel, 23
  - series, 23
  - series-multiple, 24
- Battery ignition systems, timing, rules, 235
  - care of, 116
  - testing, 255
  - timing with engine, 115
- Battery ignition systems, typical, 73
  - Atwater-Kent, type CC, 84
    - type K-2, 79
  - Connecticut, 88
  - Delco, typical, 101
    - Cadillac Eight, 122
    - Liberty Twelve Airplane, 136
    - Oldsmobile Eight, 121
    - Packard Twin Six, 129
    - Pierce-Arrow, 132
  - North East, 98
  - Philbrin, 107
  - Remy, 94
    - For U. S. military truck, 98
  - Wagner, 111
  - Westinghouse, vertical, 103
    - type SC, 106
- Battery, primary, 19 ✓
  - secondary, 19
    - box, 31
    - cells, 19
    - charging, 41
    - covers, 30
    - detailed instructions, charging, 42
    - Edison, 25
    - elements, 19
    - grids, 29
    - groups, 29
    - jars, 30
    - lead, 27
    - over-filling, 46
    - run-down, causes, 49
    - separators, 31
    - sulphation, 44
      - prevention, 44
      - vent cap, 30
- Bearings, 230
- Berling high-tension magneto, 190
- Bosch, DU4 magneto, 166
  - dual, 170
  - NU4 magneto, 173
  - type B magneto, 176
- Box, battery, 31
- Break-down, coil wiring and insulation, 259
- Breaker, 54, 75
  - care and adjustment, 236
- Buckling, battery plates, 47

## C

Cables for ignition, 239  
 Cadillac Eight, Delco, 122  
 Capacity, condenser, 59  
     storage batteries, 40  
 Care, battery ignition system, 116  
     breakers, 236  
     distributors, 242  
     dry cells, 25  
     spark plugs, 43  
     storage battery ignition, 49  
     timers, 236  
 Cells, 19  
     dry, 20  
     f storage, 25  
         Edison, 25  
         lead, 27  
             action on discharge, 35  
             cell readings, variation of, 38  
 Charging, battery, 41  
     detailed instructions, 42  
     rate, 42  
 Circuits, 2  
     parallel, 6  
         resistance of, 6  
     series, 6  
         resistance of, 6  
 Classification, magneto, 143  
     armature type, 143, 147  
     high-tension, 143, 146  
     inductor type, 143, 147  
     low-tension, 143, 146  
 Coil, adjustments, 259  
     break-down, 259  
     Ford, 160  
     high-tension, 53  
     impregnation, 55  
     induction, 53  
     low-tension, 52  
     testing, 245  
     transformer, 146, 151  
     vibrating, 64  
 Compass, magnetic, 12  
     deflection, 13  
 Condenser, 57, 86  
     capacity of, 59  
     defective, 258  
     testing, 247  
     troubles, 247  
 Condensite, 76  
 Conditions causing trouble, breakers  
     and timers, 237

Conductors, 2  
 Conduit, 241  
 Connecticut ignition system, 88  
     type H switch, 89  
     type K switch, 91  
 Corroded terminals, 46  
 Couplings, magneto, 229  
 Covers, battery, 30  
 Crank arrangements, eight-cylinder  
     engine, 120  
     four-cylinder engine, 117  
     six-cylinder engine, 118  
     twelve-cylinder engine, 127  
 Current, alternating, 15  
     direct, 21  
     electric, effects of, 8  
         chemical, 9  
         heating, 9  
         magnetic, 9  
     mechanical generation, 145  
     wave form, shuttle wound armature,  
         147  
         armature type magneto, 202  
         inductor type magneto, 202  
 Cylinders, numbering on 4-cylinder  
     engines, 117  
     6-cylinder engines, 119  
     8-cylinder engines, 120  
     12-cylinder engines, 128

## D

Defective condensers, 258  
     spark plugs, 256  
     wiring and apparatus, 257  
 Delco ignition systems, typical, 101  
     airplane engines, 136  
     Cadillac Eight, 122  
     Oldsmobile Eight, 121  
     Packard Twin Six, 129  
     Pierce-Arrow, 132  
 Depolarizing, 21  
 Determination of polarity, 14  
 Dielectric, 55  
 Dimensions, standard spark plug,  
     63  
 Direct current from dry cell, 21  
 Direction, lines of force, 10  
     current flow, 2  
 Disintegrated battery plates, 47  
 Distilled water for batteries, 37, 43  
 Distributor, 76  
     care of, 243

Dixie magneto, 205  
 Drives, magneto, 228  
 Dry battery troubles, 260  
 Dry cells, 20  
   care of, 25  
   testing, 22  
 Dual ignition systems, 152  
   Berling, 190  
   Bosch, 170  
   Eisemann, 181  
   Simms, 188  
   Splitdorf, low-tension, 153

## E

Edison storage batteries, 25  
 Effects of electric current, 8  
   resistance unit upon ignition, 77  
 Eisemann magneto, automatic spark  
   advance, 185  
   impulse starter, 187  
   timing to engine, 185  
   type G-4, 176  
   type GR-4, 181  
 Electrical horsepower, 8  
   potential, 2  
   power, 8  
   resistance, 2  
 Electricity, nature of, 1  
   use on automobiles, 1  
 Electrolyte, 2, 33  
   freezing point, 38  
   leveling cells, 47  
 Electromagnet, 14  
 Electromagnetic induction, 15  
 Electromagnetism, 12  
 Electromotive force, 2  
 Elements, battery, 19, 29  
 Engines, effect of faulty ignition,  
   261  
   failure to start, 255  
   starting, 255  
 Evaporation from storage battery, 37

## F

Field, magnetic, 10  
 Firing order, 4-cylinder engines, 117  
   6-cylinder engines, 117  
   8-cylinder engines, 119  
   12-cylinder engines, 127  
 Flames, keep away from battery, 44

Force, lines of, 10  
   in magneto, 144  
 Ford ignition system, 157  
   coil, 160  
   magneto, 157  
   timing, 160  
 Forming battery plates, 29  
 Freezing, electrolyte, 38

## G

Gap, safety, 59  
 Gassing, battery, 43  
 Generation of current, chemical, 20  
   mechanical, 145  
 Gravity, specific, 33  
   low in one cell, 38  
 Grids, battery, 29  
 Group, battery, 29

## H

Heat in storage battery, 35  
 High-tension coil, 53  
 High-tension magneto, 146, 161  
   Berling, 190  
   Bosch, DU4, 166  
   Dual, 170  
   NU4, 173  
   type B, 176  
   Eisemann, type G4, 176  
   type GR4, 181  
   Kingston, 192  
   K-W, 204  
   Mea, 194  
   Simms, 188  
   Splitdorf Aero, 209  
   Dixie, 205  
 Horsepower, 8  
 Hydraulic analogy, condenser, 58  
   electric current, 1  
 Hydrometer, 34  
   variations due to temperature, 39

## I

Ignition batteries, wiring, 23  
   parallel, 23  
   series, 23  
   series multiple, 24  
 Ignition coil testing, non-vibrating, 246  
   vibrating, 245



- Ignition, faulty, effect of, 261  
 premature, 261  
 requirements of, automotive engine, 51
- Ignition systems, battery, Atwater-Kent, type CC, 84  
 K-2, 79  
 Connecticut, 88  
 Delco typical, 101  
 Cadillac Eight, 122  
 Liberty Twelve airplane, 136  
 Oldsmobile Eight, 121  
 Packard Twin Six, 129  
 Pierce-Arrow, 132  
 North East, 98  
 Philbrin, 107  
 Remy, 94  
 U. S. military truck, 98  
 Wagner, 101  
 Westinghouse vertical, 103  
 type SC, 106
- Ignition systems, battery, testing, 255
- Ignition systems, dual, 152  
 Berling, 190  
 Bosch, 170  
 Eisemann, 181  
 Ford, 157  
 Simms, 188  
 Splitdorf, low-tension, 153
- Ignition systems, jump-spark, 56  
 non-vibrating, 56  
 operation, 56  
 typical, battery, 73  
 vibrating, 65
- Ignition systems, magneto, high-tension,  
 Berling, 190  
 Bosch DU4, 166  
 dual, 170  
 NU4, 173  
 type B, 176  
 Eisemann, type G4, 176  
 GR4, 181  
 Kingston, 192  
 K-W, 204  
 Mea, 194  
 Simms, 188  
 Splitdorf Aero, 209  
 Dixie, 205
- Ignition systems, magneto, low-tension,  
 Ford, 157  
 Remy, 154  
 Splitdorf, 153
- Ignition, things to remember, 262*
- Ignition timing, 60  
 general rules, battery, 235  
 magneto, 232  
 multiple cylinder engines, 141
- Impregnation, coil, 55
- Improper spark timing, 259
- Impulse starter, Eisemann, 187  
 Kingston, 193  
 Splitdorf, 214  
 care of, 232
- Induction, electromagnetic, 15  
 coil, 53, 64
- Inductor type magneto, principle, 197  
 Ford, 157  
 K-W, 198  
 Remy, 154  
 Splitdorf Aero, 209  
 Dixie, 205
- Installation, spark plug, 62, 243
- Instructions, battery charging, 42
- Insulation, 238  
 testing, 242
- Insulators, 2
- Interrupted primary, low-tension magneto, 149  
 shunt, low-tension magneto, 150
- Interrupter, 75  
 adjustment, 236  
 care, 236
- J
- Jars, battery, 30
- Jump-spark ignition system, 56
- K
- Kilowatt, 8
- Kilowatt-hour, 8
- Kingston Model O high-tension magneto, 192
- Kingston impulse starter, 193
- K-W high-tension inductor magneto, 204  
 master vibrator, 67
- L
- Law, Ohm's, 4
- Level, electrolyte, in cells, 37
- Liberty Twelve aircraft ignition, 136
- Lines of force, 10  
 around wire carrying current, 13  
 in magneto, 144
- Locating misfiring cylinder, 256
- Low-tension coil, 52  
 magneto, 146

- Low-tension magneto, Ford, 157  
 Remy, 154  
 Splitdorf, 153  
 Lubrication 230
- M
- Magnetic attraction, 11  
 compass, 12  
 field, 10, 12  
 metals, 10  
 poles, 10  
 repulsion, 11
- Magnetism, 9
- Magneto classification, 143  
 armature type, 143, 147  
 high-tension, 143, 146  
 inductor type, 143, 147  
 low-tension, 143, 146
- Magneto couplings, 229
- Magneto drives, 228
- Magneto, dual, Berling, 190  
 Bosch, 170  
 Eisemann, 181  
 Ford, 157  
 Simms, 183  
 Splitdorf, low-tension, 153
- Magneto, high-tension, armature type,  
 Berling, 190  
 Bosch, 170  
 Eisemann, 176  
 Kingston, 192  
 Mea, 194  
 Simms, 188  
 inductor type, K-W, 198  
 Splitdorf Aero, 209  
 Dixie, 205
- Magneto ignition system, testing, 256
- Magneto, low-tension, Ford, 157  
 interrupted primary, 149  
 shunt, 150  
 Remy inductor, 154  
 Splitdorf, 153
- Magneto timing, general rules, 232  
 to the engine, 234
- Magneto troubles, 260
- Magnets, artificial, 10  
 compound, 145  
 Ford, 252  
 natural, 9  
 recharging, 249  
 simple, 144
- Make-and-break ignition, 52
- Manual spark advance, 78
- Master vibrator, 67  
 K-W, 67  
 Pfanstiehl, 68
- Mea magneto, 194
- Mechanical generation of current, 145
- Misfiring cylinder, locating, 256
- Mounting ignition apparatus, 225
- N
- Non-conductors, 2
- Non-electrolyte, 2
- Non-magnetic metals, 10
- North East ignition system, 98
- Numbering cylinders, method of, 4-cylinder, 117  
 6-cylinder, 119  
 8-cylinder, 120  
 12-cylinder, 128
- O
- Ohm, 2
- Ohm's Law, 4  
 formula for, 5
- Oldsmobile Eight, delco system, 121
- Operation, jump-spark ignition system, 56
- Order of events, four-stroke cycle engine, 233
- Overfilling the battery, effect of, 46
- P
- Packard Twin Six, 129
- Parallel circuits, 6
- Pfanstiehl master vibrator, 68
- Philbrin ignition system, 107
- Plates, battery, 26, 28  
 buckling of, 47  
 disintegration, 47
- Plug, spark, 59  
 location in cylinder, 62  
 standard dimensions of, 63
- Plugs, vent, battery, 42
- Polarity of electromagnet, 14
- Polarization, 20
- Poles, magnetic, 10
- Potential, electric, 2
- Power, 8
- Premature ignition, 261
- Primary battery, 19

Primary winding, 54  
Principles of ignition timing, 69

## R

Rain water for storage battery, 37  
Readings, cell, variation, 38  
Recharging magnets, 249  
    Ford, 252  
Relation between direction of current  
    and magnetic field, 15  
Remy battery ignition system, 94  
    for U. S. military trucks, 98  
    inductor type magneto, 154  
Repulsion, magnetic, 11  
Requirements, aircraft ignition, 135  
    automotive ignition, 51  
Resistance, 2  
    effect of temperature on, 4  
    table, 3  
    unit, 77, 259  
    effect on ignition, 77  
Resistor, ballast, Westinghouse, 105  
Right-hand rule, 17

## S

Safety gap, 59  
Secondary battery, 19  
    winding, 54  
Sediment, 48  
    space, 30  
Separators, storage battery, 31  
    rubber, 32  
    wood, 31  
Series circuits, 6  
    plug ignition, 70  
Simms dual magneto, 188  
Solenoid, 14  
Spark advance and retard, 69  
    manual and automatic, 78  
Spark plugs, care of, 243  
    cleaning, 245  
    defective, 256  
    installation, 62, 243  
    location, 62  
    standard dimensions, 63  
    testing, 244  
Spark timing, 60  
    improper, 259  
Specific gravity, 33  
    low in one cell, 38

Splitdorf Aero magneto, 209  
    Dixie magneto, 205  
    low-tension magneto, 153  
Starting the engine, 255  
Storage battery, 25  
    action, charge, 35  
    discharge, 36  
    capacity, 40  
    care, winter, 49  
    Edison, 25  
    heat formed in, 36  
    lead battery, 27  
    run down, 49  
    sediment, 30  
    testing, 37  
    troubles, 260  
Storage cells, 25  
Sulphation, storage battery, 44  
    prevention, 45  
Switch, Aero, 214  
    automatic, 89, 91  
    Bosch, 173  
    Connecticut H, 89  
    K, 91  
    Dixie, 209  
    Eisemann, 183  
    Philbrin, 109  
    Westinghouse, 105

## T

Temperature, effect, hydrometer read-  
    ings, 39  
    resistance, 4  
Terminals and wiring, 238  
Terminals, corrosion of, 46  
    negative, 2  
    positive, 2  
Testing, battery ignition system, 255  
    condenser, 247  
    dry cells, 22  
    high-tension insulation, 242  
    ignition coil, 245  
    magneto, 256  
    spark plugs, 244  
    storage battery, 37  
Three-terminal coil, 65  
Timer, 54, 66, 259  
    care of, 236  
Timing battery ignition system, 115  
    eight- and twelve-cylinder systems,  
        141  
    Ford system, 160

- Timing battery ignition system, im-  
proper, 259  
magneto, general, 232  
to engine, 234  
Transformer coil, 146  
Troubles, dry battery, 260  
magneto, 260  
storage battery, 260  
Types of magnets, 144  
Typical battery ignition system, 73
- U
- Unit, resistance, 77  
effect on ignition, 77
- V
- Variations in cell readings, hydrometer, 38  
Vent caps, battery, 30  
plugs, battery, 42  
Vibrating ignition system, 65  
induction coil, 64  
Vibrators, master, 67  
K-W, 67  
Pfanstiehl, 68  
Volt, 2  
Voltmeter, 5
- W
- Water analogy, condenser, 58  
electric current, 1  
induction, 16  
Water, evaporation, storage battery, 37  
adding to storage battery, 37  
Watt, 8  
Wave, current, shuttle wound armature  
magneto, 147  
inductor type magneto, 202  
Westinghouse ignition system, vertical,  
103  
type SC, 106
- Winding, primary, 54  
secondary, 54  
Wires, resistance of, 3  
Wiring and terminals, 238  
Wiring diagrams, Atwater Kent, type CC,  
86  
K-2, 82  
Berling magneto, 192  
Bosch dual, 172  
DU4, 166  
NU4, 175  
Connecticut type H, 92  
K, 93  
Delco, typical, 103  
Cadillac Eight, 125  
Liberty Aircraft, 141  
Oldsmobile Eight, 123  
Packard Twin Six, 129  
Pierce-Arrow, 135  
Eisemann G4, 180  
GR4, 184  
Ford, 66, 159  
K-W magneto, 204  
low-tension magneto, interrupted  
primary, 149  
shunt, 151  
Philbrin, 108  
Remy inductor magneto, 157  
2-terminal coil, battery system, 96  
3-terminal coil, battery system, 97  
Simms magneto, 189  
Splitdorf Aero magneto, 217  
for airplane, 221  
Dixie magneto, 208  
low-tension dual, 153  
Wagner, 115  
Westinghouse vertical, 105  
type SC, 107  
Wiring, high-tension, 241  
Wiring ignition batteries, in parallel, 23  
series, 23  
series multiple, 24

FEB 18 1921

68 50 AA A 30 :+!•









DATE



UNIVERSITY OF MICHIGAN



205 7894

1945

1946

---

---