

United States Patent Office

Des. 212,152
Patented Sept. 3, 1968

212,152

AUTOMOBILE

Henry G. Haga, Bloomfield Hills, Mich., assignor to General Motors Corporation, Detroit, Mich., a corporation of Delaware

Filed Jan. 16, 1968, Ser. No. 10,183

Term of patent 14 years

(Cl. D14-3)

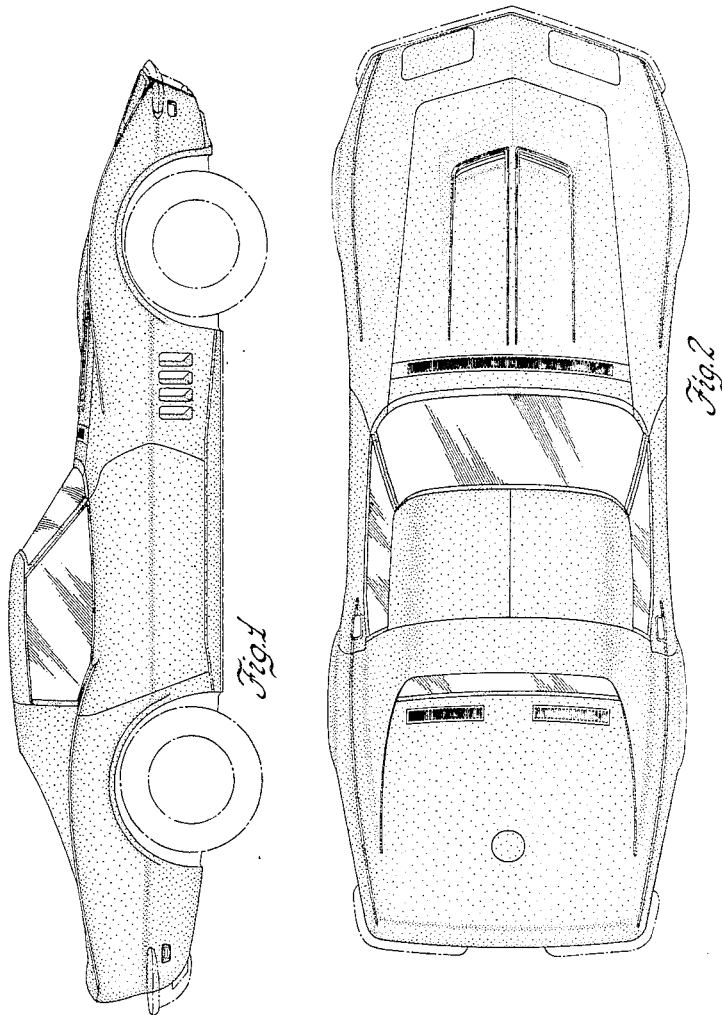

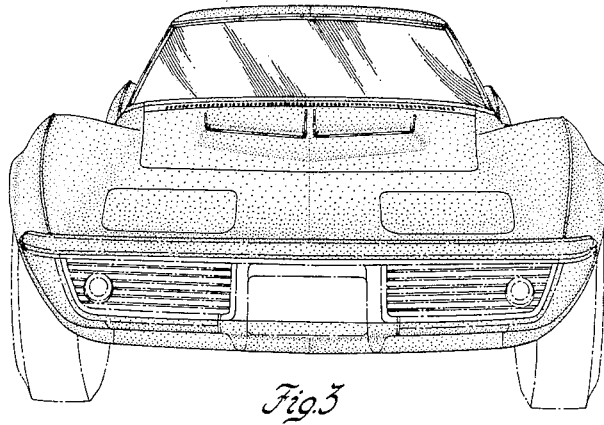

Fig. 3

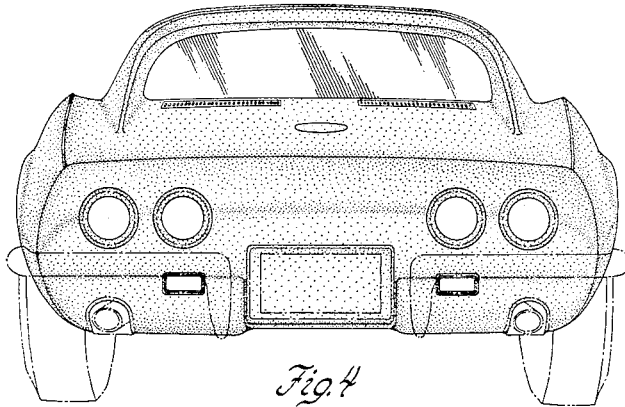

Fig. 4

FIGURE 1 is a side elevational view of an automobile showing my new design;

FIGURE 2 is a top plan view;

FIGURE 3 is a front elevational view; and

FIGURE 4 is a rear elevational view.

The dominant features of my design reside in the full line portions of the drawings.

I claim:

The ornamental design for an automobile, substantially as shown and described.

References Cited

UNITED STATES PATENTS

D. 206,063 10/1966 Mitchell D14—3

OTHER REFERENCES

Chevrolet Corvette brochure, 1965, received Feb. 4, 1965, page 8, Corvette side vents.

Road and Track, October 1967, page 29, 1964 Ferrari GTO at lower right.

WALLACE R. BURKE, *Primary Examiner.*

J. PAUL GUERTIN, *Assistant Examiner.*