

180,594

## AUTOMOBILE

Edward E. Glowacke, Birmingham, and Robert J. Scheelk,  
Oak Park, Mich., assignors to General Motors Corporation,  
Detroit, Mich., a corporation of Delaware

Application December 22, 1955, Serial No. 39,443

Term of patent 7 years

(Cl. D14—3)

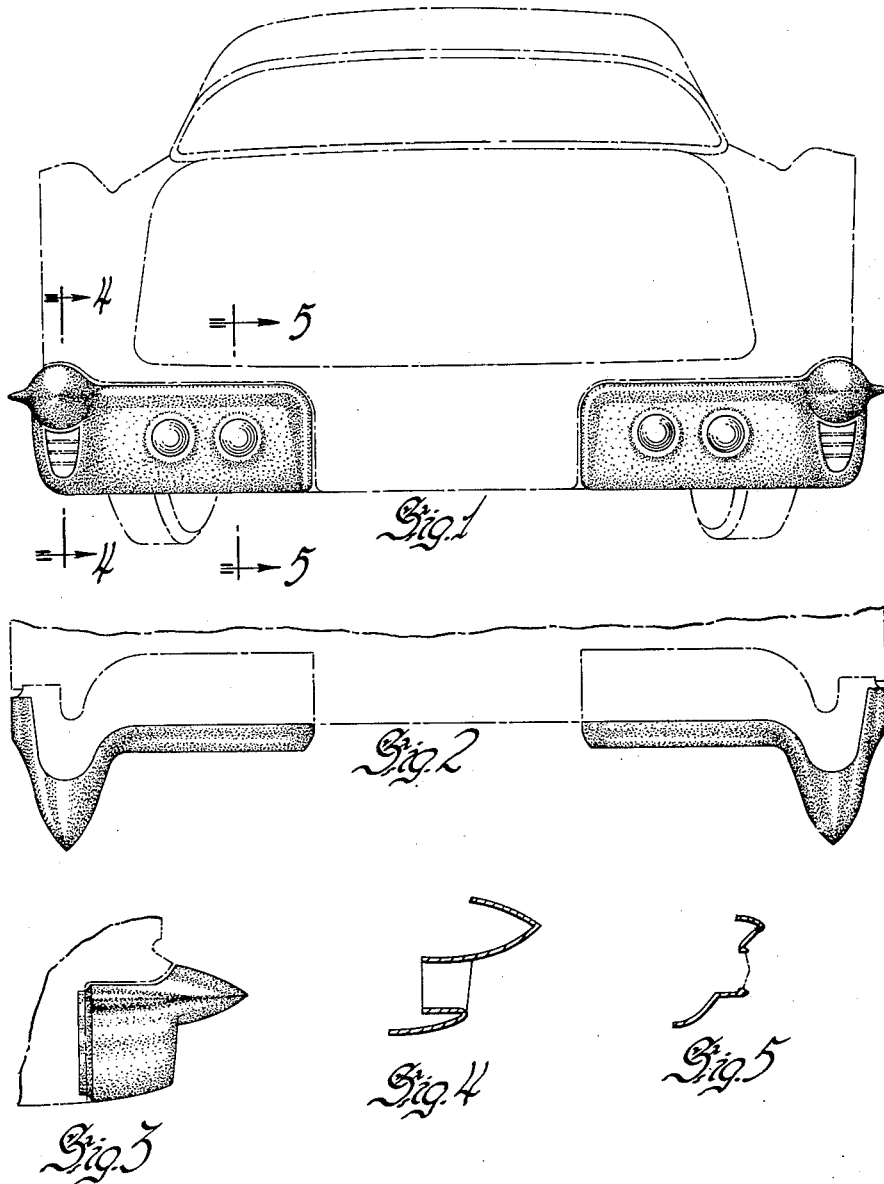

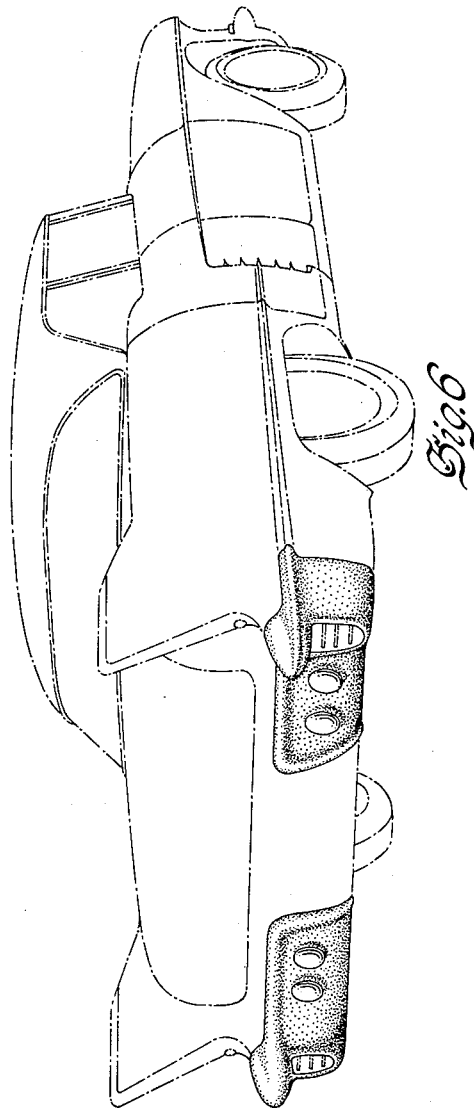

Figure 1 is a rear elevational view of an automobile embodying our new design;  
Figure 2 is a partial top plan view of the rear portion of the automobile of Figure 1;  
Figure 3 is a side elevational view of that portion of the automobile shown in Figure 2;  
Figure 4 is a sectional view on the plane indicated by line 4—4 of Figure 1; and  
Figure 5 is a sectional view on the plane indicated by line 5—5 of Figure 1.  
Figure 6 is a rear perspective view of the automobile of Figure 1 taken from the right hand side thereof.  
The dominant features of our design reside in the full

line portions of the drawings. The front of the automobile is of conventional configuration.

We claim:  
The ornamental design for an automobile, substantially as shown and described.

**References Cited** in the file of this patent  
Motor World, August 1953, page 25, car lower right, front bumpers.  
Motor Trend, May 1954, page 23, car lower right, rear bumpers.  
Motor Trend, October 1955, page 69, car upper right, rear bumpers.